

### FEATURES

#### Complete Receiver on a Chip: Monoceiver™ Mixer

- 15 dBm 1 dB Compression Point
- 8 dBm Input Third Order Intercept
- 500 MHz RF and LO Bandwidths

#### Linear IF Amplifier

- Linear-in-dB Gain Control
- MGC or AGC with RSSI Output

#### Quadrature Demodulator

- On-Board Phase-Locked Quadrature Oscillator
- Demodulates IFs from 400 kHz to 12 MHz
- Can Also Demodulate AM, CW, SSB

#### Low Power

- 25 mW at 3 V
- CMOS Compatible Power-Down

#### Interfaces to AD7013 and AD7015 Baseband Converters

### APPLICATIONS

- GSM, CDMA, TDMA, and TETRA Receivers
- Satellite Terminals
- Battery-Powered Communications Receivers

### PIN CONFIGURATION

#### 20-Lead SSOP (RS Suffix)

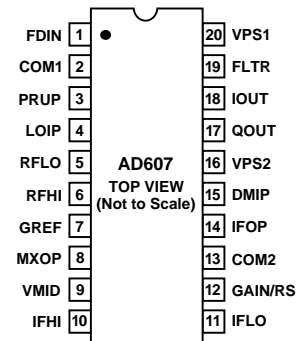

### GENERAL DESCRIPTION

The AD607 is a 3 V low power receiver IF subsystem for operation at input frequencies as high as 500 MHz and IFs from 400 kHz to 12 MHz. It consists of a mixer, IF amplifiers, I and Q demodulators, a phase-locked quadrature oscillator, AGC detector, and a biasing system with external power-down.

The AD607's low noise, high intercept mixer is a doubly-balanced Gilbert cell type. It has a nominal -15 dBm input referred 1 dB compression point and a -8 dBm input referred third-order intercept. The mixer section of the AD607 also includes a local oscillator (LO) preamplifier, which lowers the required LO drive to -16 dBm.

The gain control input can serve as either a manual gain control (MGC) input or an automatic gain control (AGC) voltage-based RSSI output. In MGC operation, the AD607 accepts an external gain-control voltage input from an external AGC detector or a DAC. In AGC operation, an onboard detector and an external averaging capacitor form an AGC loop that holds the IF output level at  $\pm 300$  mV. The voltage across this capacitor then provides an RSSI output.

The I and Q demodulators provide inphase and quadrature baseband outputs to interface with Analog Devices' AD7013 (IS54, TETRA, MSAT) and AD7015 (GSM) baseband converters. A quadrature VCO phase-locked to the IF drives the I and Q demodulators. The I and Q demodulators can also demodulate AM; when the AD607's quadrature VCO is phase locked to the received signal, the in-phase demodulator becomes a synchronous product detector for AM. The VCO can also be phase-locked to an external beat-frequency oscillator (BFO), and the demodulator serves as a product detector for CW or SSB reception. Finally, the AD607 can be used to demodulate BPSK using an external Costas Loop for carrier recovery.

### REV. 0

Information furnished by Analog Devices is believed to be accurate and reliable. However, no responsibility is assumed by Analog Devices for its use, nor for any infringements of patents or other rights of third parties which may result from its use. No license is granted by implication or otherwise under any patent or patent rights of Analog Devices.

© Analog Devices, Inc., 1995

One Technology Way, P.O. Box 9106, Norwood, MA 02062-9106, U.S.A.  
Tel: 617/329-4700 Fax: 617/326-8703

# AD607—SPECIFICATIONS

(@ T<sub>A</sub> = + 25°C, Supply = 3.0 V, IF = 10.7 MHz, unless otherwise noted)

Model	Conditions	AD607ARS			Units
		Min	Typ	Max	
<b>DYNAMIC PERFORMANCE</b>					
<b>MIXER</b>					
Maximum RF and LO Frequency Range	For Conversion Gain > 20 dB		500		MHz
Maximum Mixer Input Voltage	For Linear Operation; Between RFHI and RFLO		±54		mV
Input 1 dB Compression Point	RF Input Terminated in 50 Ω		-15		dBm
Input Third-Order Intercept	RF Input Terminated in 50 Ω		-5		dBm
Noise Figure	Matched Input, Max Gain, f = 83 MHz, IF = 10.7 MHz		14		dB
	Matched Input, Max Gain, f = 144 MHz, IF = 10.7 MHz		12		dB
Maximum Output Voltage at MXOP	Z <sub>IF</sub> = 165 Ω, at Input Compression		±1.3		V
Mixer Output Bandwidth at MXOP	-3 dB, Z <sub>IF</sub> = 165 Ω		45		MHz
LO Drive Level	Mixer LO Input Terminated in 50 Ω		-16		dBm
LO Input Impedance	LOIP to VMID		1		kΩ
Isolation, RF to IF	RF = 240 MHz, IF = 10.7 MHz, LO = 229.3 MHz		30		dB
Isolation, LO to IF	RF = 240 MHz, IF = 10.7 MHz, LO = 229.3 MHz		20		dB
Isolation, LO to RF	RF = 240 MHz, IF = 10.7 MHz, LO = 229.3 MHz		40		dB
Isolation, IF to RF	RF = 240 MHz, IF = 10.7 MHz, LO = 229.3 MHz		70		dB
<b>IF AMPLIFIERS</b>					
Noise Figure	Max Gain, f = 10.7 MHz		17		dB
Input 1 dB Compression Point	IF = 10.7 MHz		-15		dBm
Output Third-Order Intercept	IF = 10.7 MHz		+18		dBm
Maximum IF Output Voltage at IFOP	Z <sub>IF</sub> = 600 Ω		±560		mV
Output Resistance at IFOP	From IFOP to VMID		15		Ω
Bandwidth	-3 dB at IFOP, Max Gain		45		MHz
<b>GAIN CONTROL</b>					
Gain Control Range	(See Figures 43 and 44) Mixer + IF Section, GREF to 1.5 V		90		dB
Gain Scaling	GREF to 1.5 V		20		mV/dB
	GREF to General Reference Voltage V <sub>R</sub>		75/V <sub>R</sub>		dB/V
Gain Scaling Accuracy	GREF to 1.5 V, 80 dB Span		±1		dB
Bias Current at GAIN/RSSI			5		μA
Bias Current at GREF			1		μA
Input Resistance at GAIN, GREF			1		MΩ
<b>I AND Q DEMODULATORS</b>					
Required DC Bias at DMIP			VPOS/2		V dc
Input Resistance at DMIP	From DMIP to VMID		50		kΩ
Input Bias Current at DMIP			2		μA
Maximum Input Voltage	IF > 3 MHz		±150		mV
	IF ≤ 3 MHz		±75		mV
Amplitude Balance	IF = 10.7 MHz, Outputs at 600 mV p-p, F = 100 kHz		±0.2		dB
Quadrature Error	IF = 10.7 MHz, Outputs at 600 mV p-p, F = 100 kHz		-1.2		Degrees
Phase Noise in Degrees	IF = 10.7 MHz, F = 10 kHz		-100		dBc/Hz
Demodulation Gain	Sine Wave Input, Baseband Output		18		dB
Maximum Output Voltage	R <sub>L</sub> ≥ 20 kΩ		±1.23		V
Output Offset Voltage	Measured from I <sub>OUT</sub> , Q <sub>OUT</sub> to VMID		10		mV
Output Bandwidth	Sine Wave Input, Baseband Output		1.5		MHz
<b>PLL</b>					
Required DC Bias at FDIN			VPOS/2		V dc
Input Resistance at FDIN	From FDIN to VMID		50		kΩ
Input Bias Current at FDIN			200		nA
Frequency Range			0.4 to 12		MHz
Required Input Drive Level	Sine Wave Input at Pin 1		400		mV
Acquisition Time to ±3°	IF = 10.7 MHz		16.5		μs
<b>POWER-DOWN INTERFACE</b>					
Logical Threshold	For Power Up on Logical High		2		V dc
Input Current for Logical High			75		μA
Turn-On Response Time	To PLL Locked		16.5		μs
Standby Current			550		μA
<b>POWER SUPPLY</b>					
Supply Range		2.7		5.5	V
Supply Current	Midgain, IF = 10.7 MHz		8.5		mA
<b>OPERATING TEMPERATURE</b>					
T <sub>MIN</sub> to T <sub>MAX</sub>	Operation to 2.7 V Minimum Supply Voltage	-25		+85	°C
	Operation to 4.5 V Minimum Supply Voltage	-40		+85	°C

Specifications subject to change without notice.

### ABSOLUTE MAXIMUM RATINGS<sup>1</sup>

Supply Voltage VPS1, VPS2 to COM1, COM2 . . . . . +5.5 V  
 Internal Power Dissipation<sup>2</sup> . . . . . 600 mW  
 2.7 V to 5.5 V Operating Temperature Range  
 . . . . . -25°C to +85°C  
 4.5 V to 5.5 V Operating Temperature Range  
 . . . . . -40°C to +85°C  
 Storage Temperature Range . . . . . -65°C to +150°C  
 Lead Temperature Range (Soldering 60 sec) . . . . . +300°C

### NOTES

<sup>1</sup>Stresses above those listed under “Absolute Maximum Ratings” may cause permanent damage to the device. This is a stress rating only and functional operation of the device at these or any other conditions above those indicated in the operational section of this specification is not implied. Exposure to absolute maximum rating conditions for extended periods may affect device reliability.

<sup>2</sup>Thermal Characteristics: 20-lead SSOP Package:  $\theta_{JA} = 126^{\circ}\text{C}/\text{W}$ .

### ORDERING GUIDE

Model	Temperature Range	Package Description	Package Option
AD607ARS	-25°C to +85°C for 2.7 V to 5.5 V Operation; -40°C to +85°C for 4.5 V to 5.5 V Operation	20-Pin Plastic SSOP	RS-20

### CAUTION

ESD (electrostatic discharge) sensitive device. Electrostatic charges as high as 4000 V readily accumulate on the human body and test equipment and can discharge without detection. Although the AD607 features proprietary ESD protection circuitry, permanent damage may occur on devices subjected to high energy electrostatic discharges. Therefore, proper ESD precautions are recommended to avoid performance degradation or loss of functionality.



# AD607

## PIN DESCRIPTION

Pin	Mnemonic	Reads	Function
1	FDIN	Frequency Detector Input	PLL input for I/Q demodulator quadrature oscillator, $\pm 400$ mV drive required from external oscillator. Must be biased at $V_P/2$ .
2	COM1	Common #1	Supply common for RF front end and main bias.
3	PRUP	Power-Up Input	3 V/5 V CMOS compatible power-up control; logical high = powered-up; max input level = $V_{PS1} = V_{PS2}$ .
4	LOIP	Local Oscillator Input	LO input, ac coupled $\pm 54$ mV LO input required ( $-16$ dBm for $50 \Omega$ input termination).
5	RFLO	RF "Low" Input	Usually connected to ac ground.
6	RFHI	RF "High" Input	AC coupled, $\pm 56$ mV, max RF input for linear operation.
7	GRES	Gain Reference Input	High impedance input, typically 1.5 V, sets gain scaling.
8	MXOP	Mixer Output	High impedance, single-sided current output, $\pm 1.3$ V max voltage output ( $\pm 6$ mA max current output).
9	VMID	Midsupply Bias Voltage	Output of the midsupply bias generator ( $VMID = V_{POS}/2$ ).
10	IFHI	IF "High" Input	AC coupled IF input, $\pm 56$ mV max input for linear operation.
11	IFLO	IF "Low" Voltage	Reference node for IF input; auto-offset null.
12	GAIN/RSSI	Gain Control Input/RSSI Output	High impedance input, 0 V–2 V using 3 V supply, max gain at $V = 0$ . RSSI Output when using Internal AGC Detector; RSSI voltage is across AGC Capacitor connected to this pin.
13	COM2	Common #2	Supply common for IF stages and demodulator.
14	IFOP	IF Output	Low impedance, single-sided voltage output, +5 dBm ( $\pm 560$ mV) max.
15	DMIP	Demodulator Input	Signal input to I and Q demodulators $\pm 150$ mV max input at IF $> 3$ MHz for linear operation; $\pm 75$ mV max input at IF $< 3$ MHz for linear operation. Must be biased at $V_P/2$ .
16	VPS2	VPOS Supply #2	Supply to high-level IF, PLL, and demodulators.
17	QOUT	Quadrature Output	Low impedance Q baseband output $\pm 1.23$ V full scale in $20 \text{ k}\Omega$ min load; ac coupled.
18	IOUT	In-Phase Output	Low impedance I baseband output; $\pm 1.23$ V full scale in $20 \text{ k}\Omega$ min load; ac coupled.
19	FLTR	PLL Loop Filter	Series RC PLL Loop filter, connected to ground.
20	VPS1	VPOS Supply #1	Supply to mixer, low level IF, PLL, and gain control.

## PIN CONNECTION

### 20-Pin SSOP (RS-20)

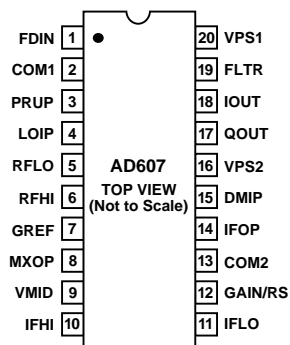

# Typical Performance Characteristics—AD607

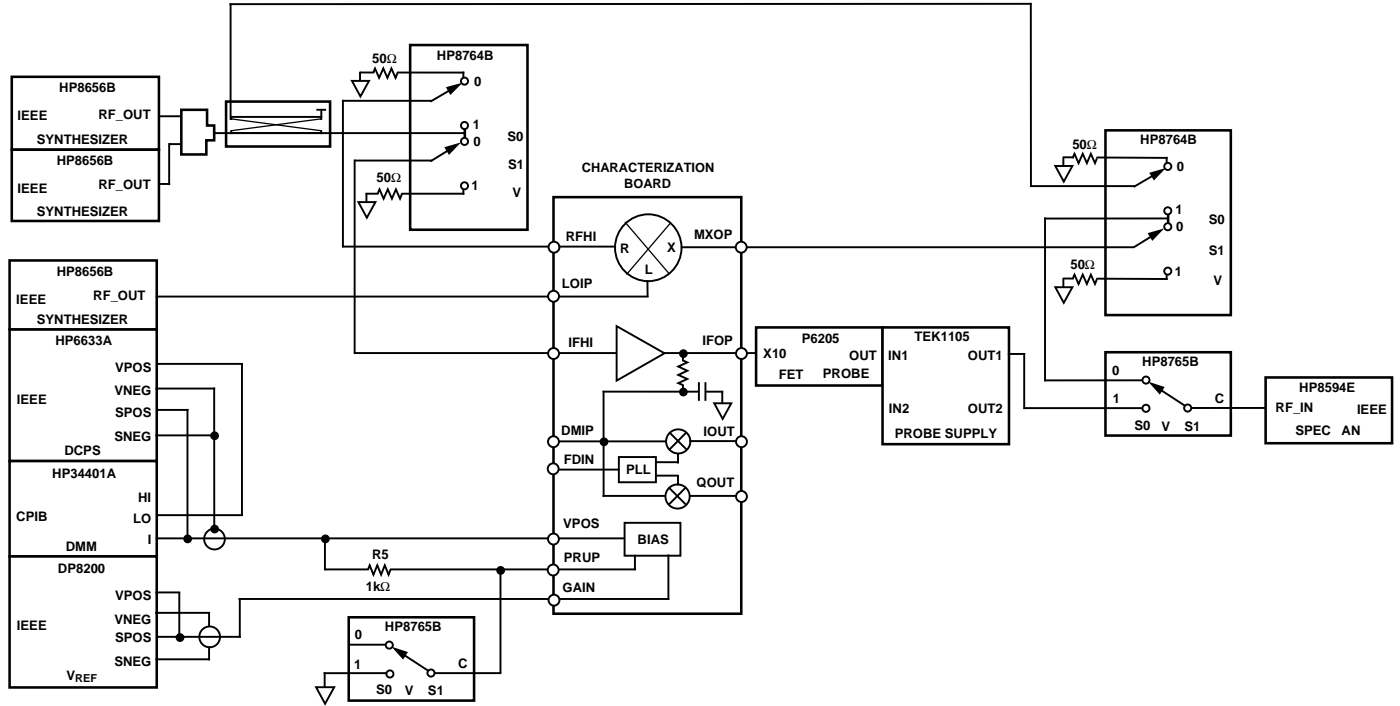

Figure 1. Mixer/Amplifier Test Set

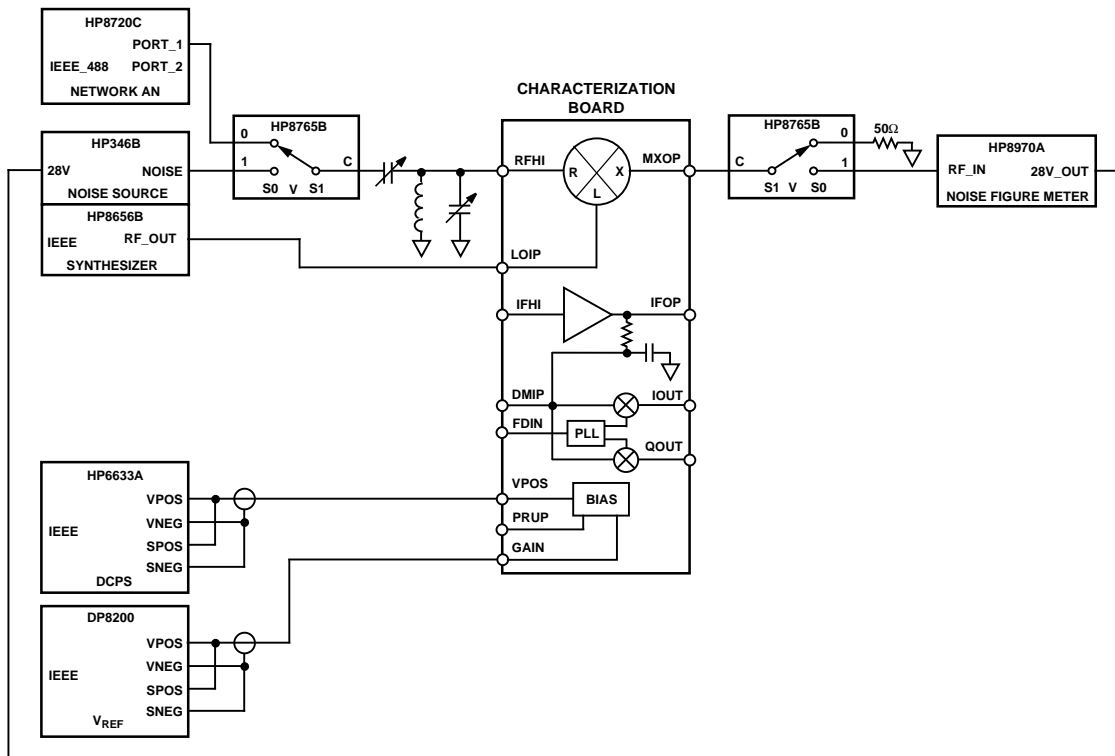

Figure 2. Mixer Noise Figure Test Set

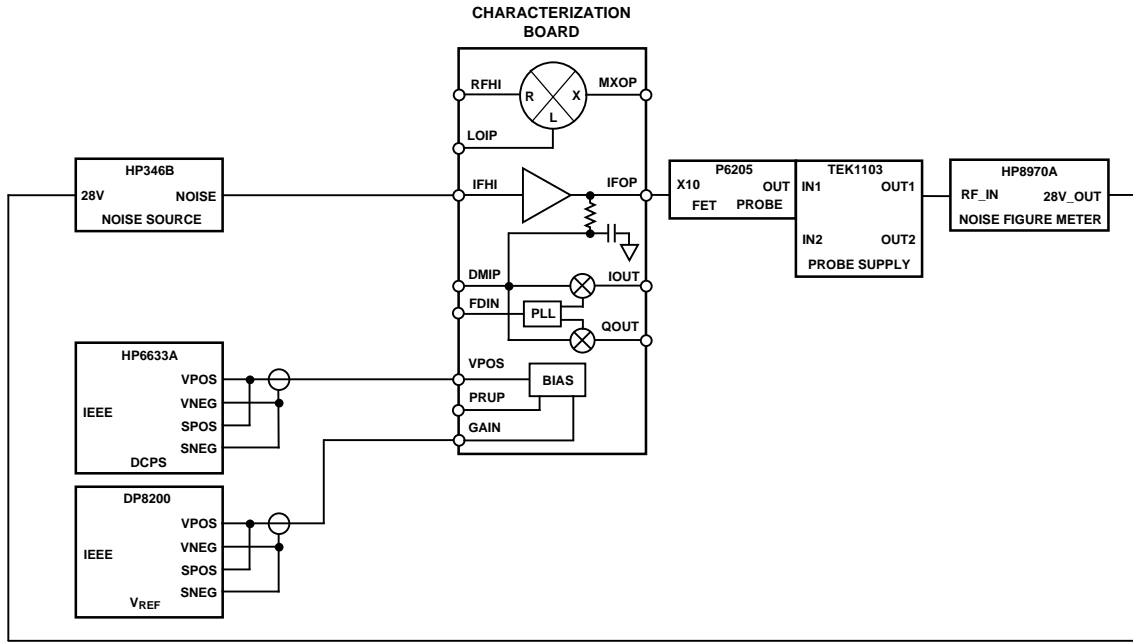

Figure 3. IF Amp Noise Figure Test Set

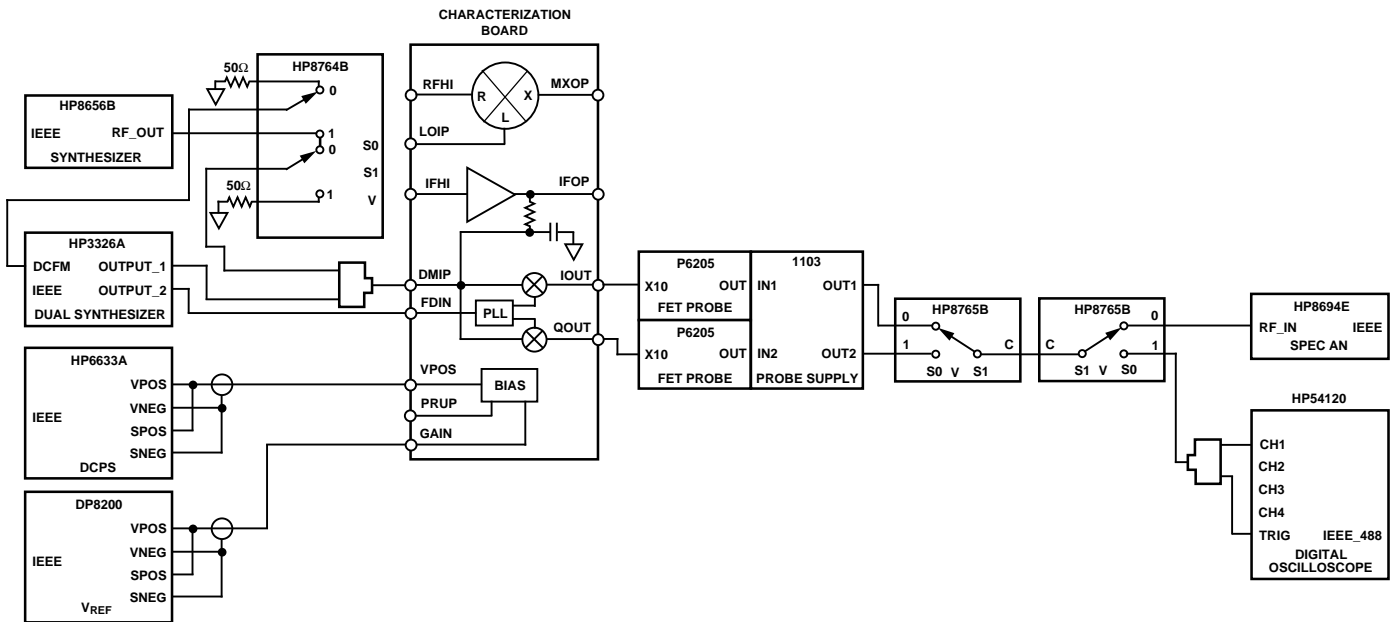

Figure 4. PLL/Demodulator Test Set

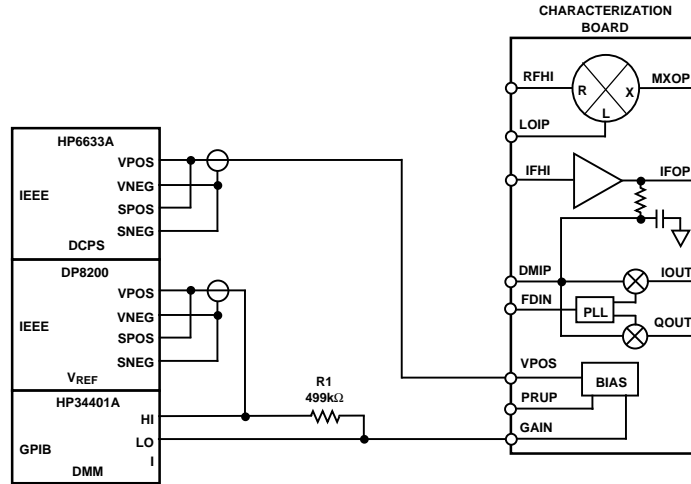

Figure 5. GAIN Pin Bias Test Set

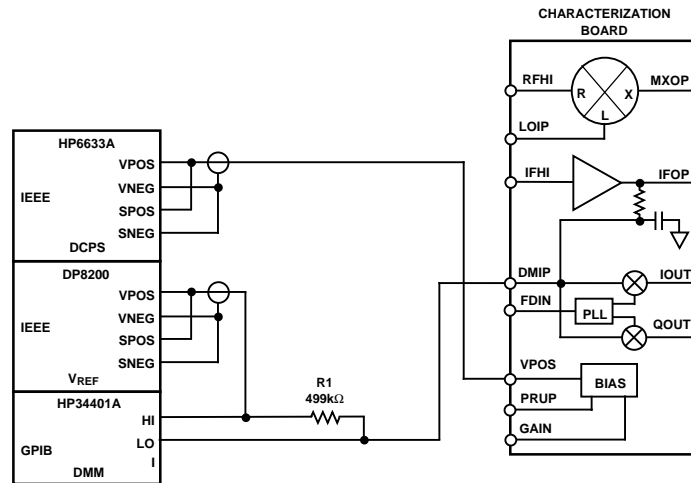

Figure 6. Demodulator Bias Test Set

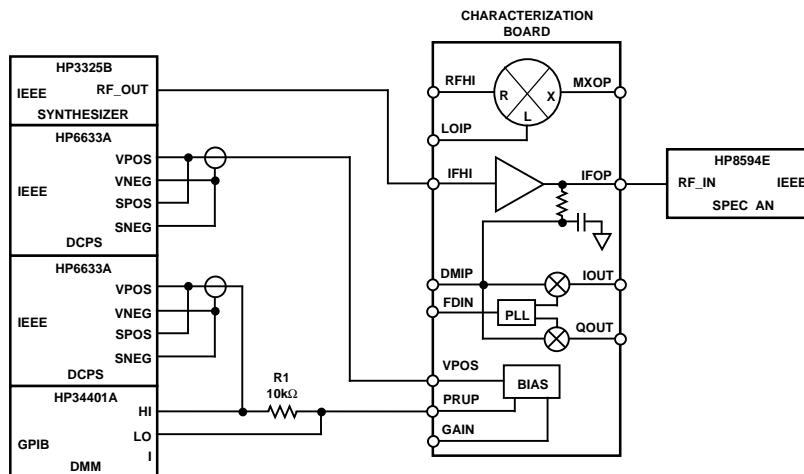

Figure 7. Power-Up Threshold Test Set

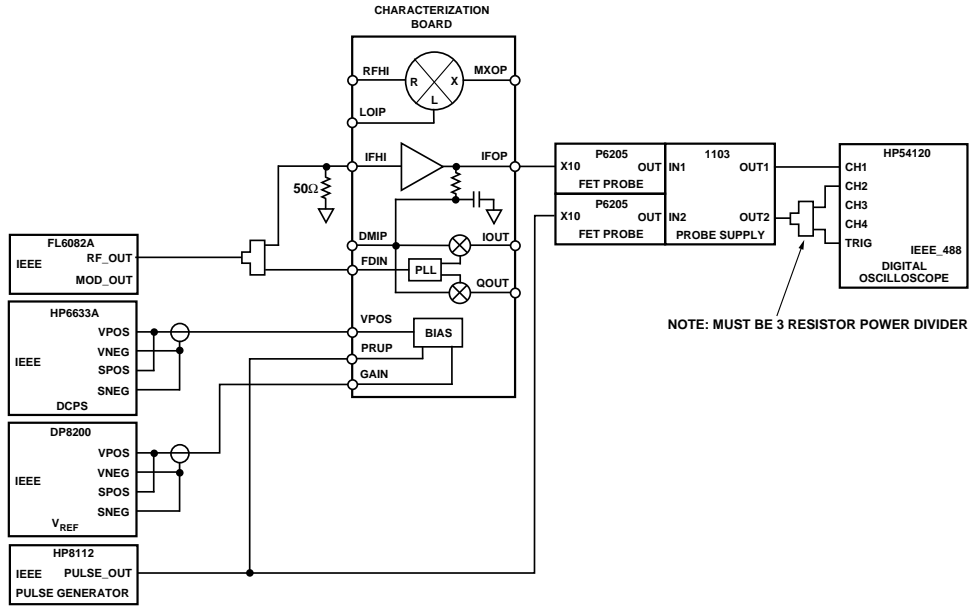

Figure 8. Power-Up Test Set

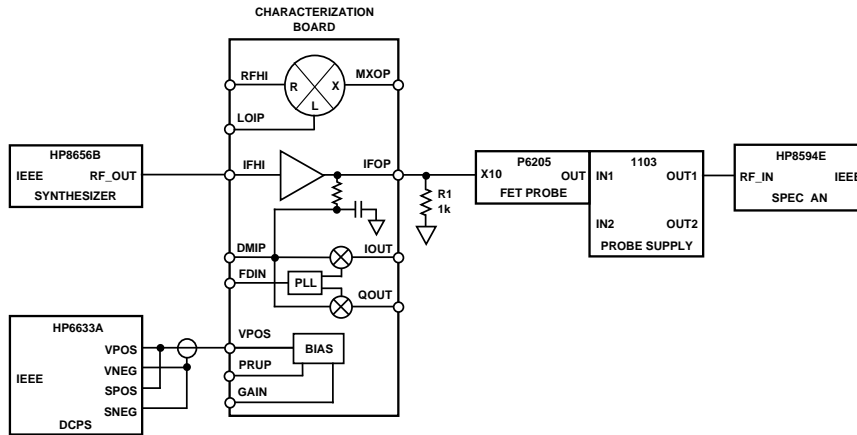

Figure 9. IF Output Impedance Test Set

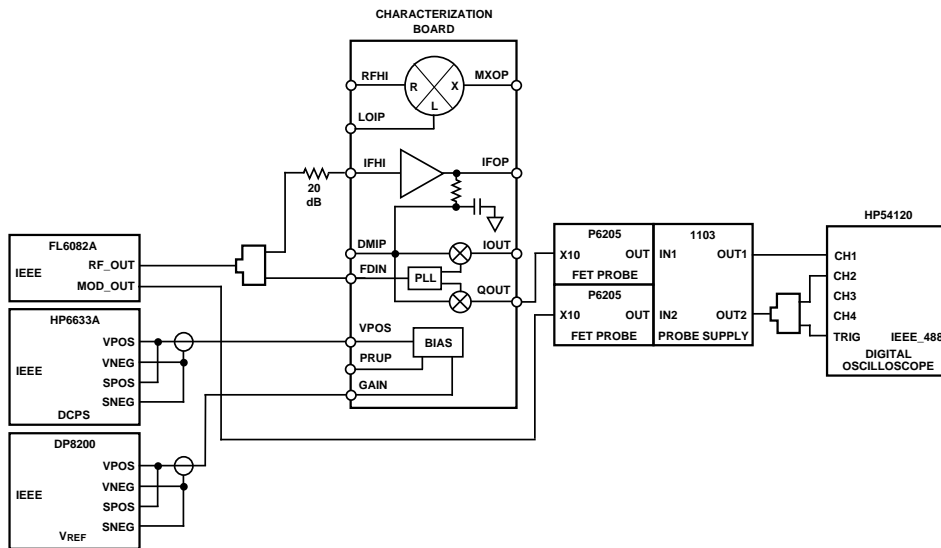

Figure 10. PLL Settling Time Test Set

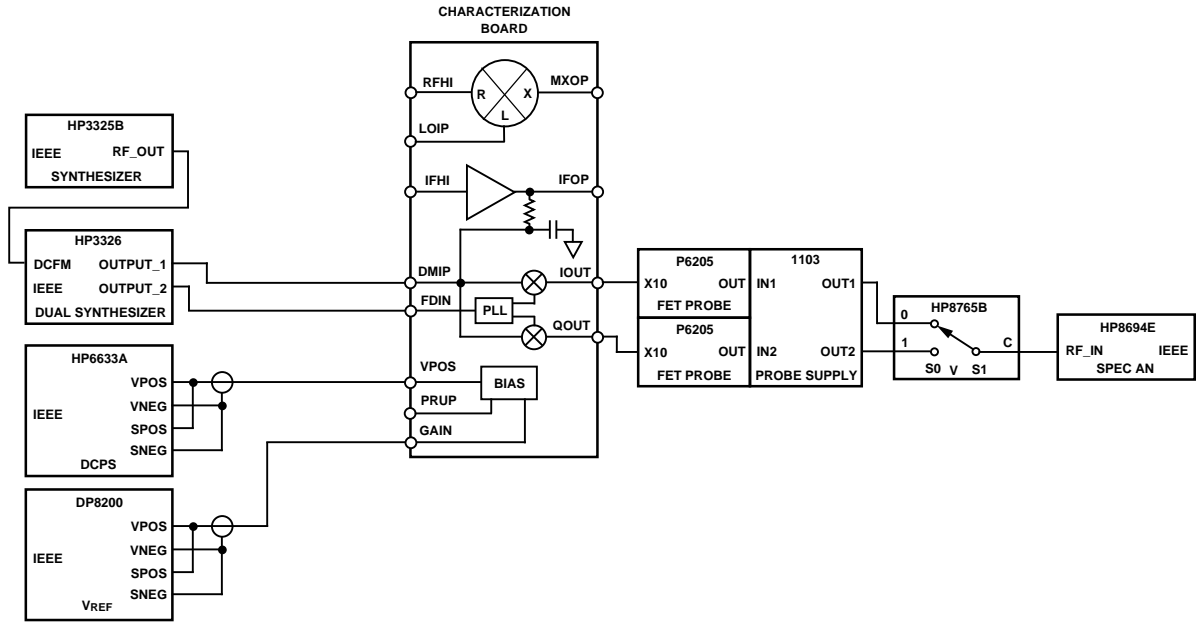

Figure 11. Quadrature Accuracy Test Set

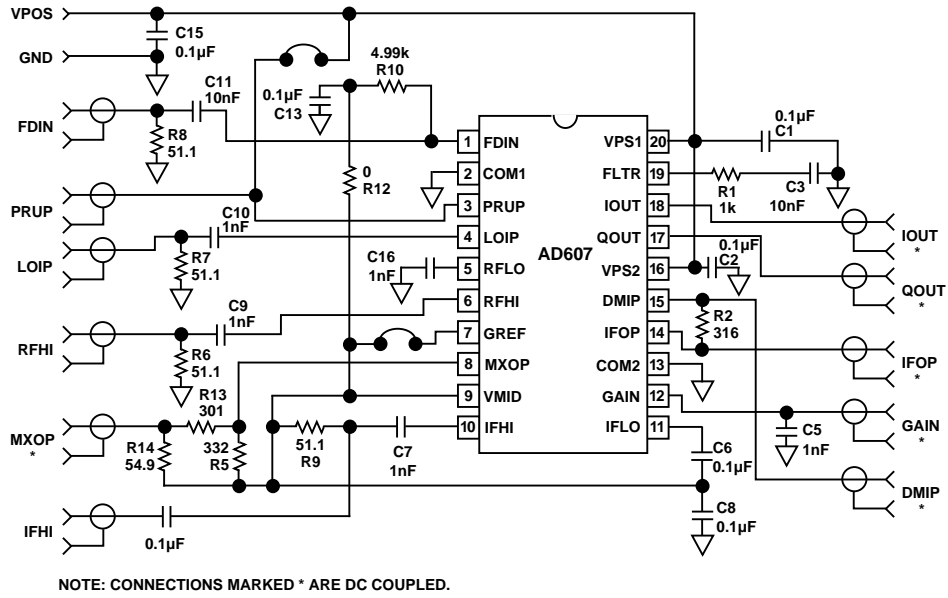

Figure 12. AD607 Characterization Board

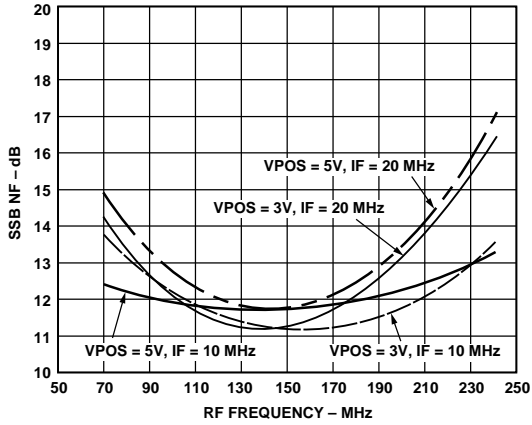

Figure 13. Mixer Noise Figure vs. Frequency

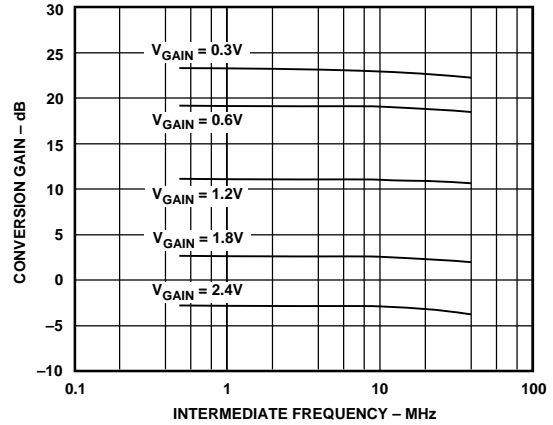

Figure 16. Mixer Conversion Gain vs. IF,  $T = +25^{\circ}\text{C}$ ,  $V_{\text{POS}} = 3\text{ V}$ ,  $V_{\text{REF}} = 1.5\text{ V}$

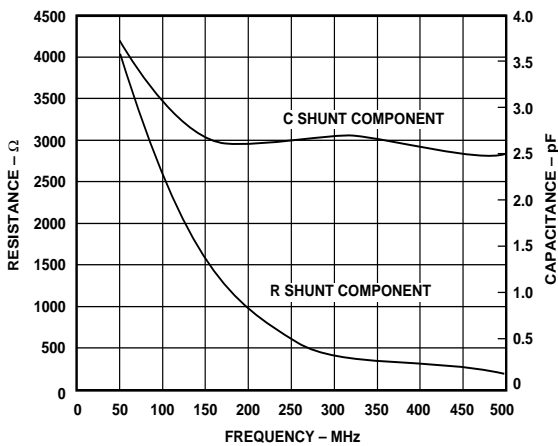

Figure 14. Mixer Input Impedance vs. Frequency,  $V_{\text{POS}} = 3\text{ V}$ ,  $V_{\text{GAIN}} = 0.8\text{ V}$

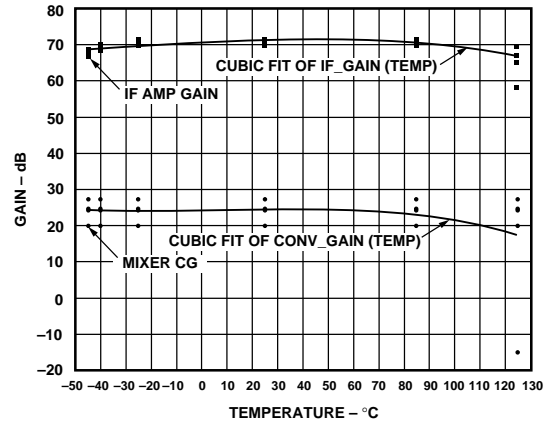

Figure 17. Mixer Conversion Gain and IF Amplifier Gain vs. Temperature,  $V_{\text{POS}} = 3\text{ V}$ ,  $V_{\text{GAIN}} = 0.3\text{ V}$ ,  $V_{\text{REF}} = 1.5\text{ V}$ ,  $I_{\text{F}} = 10.7\text{ MHz}$ ,  $R_{\text{F}} = 250\text{ MHz}$

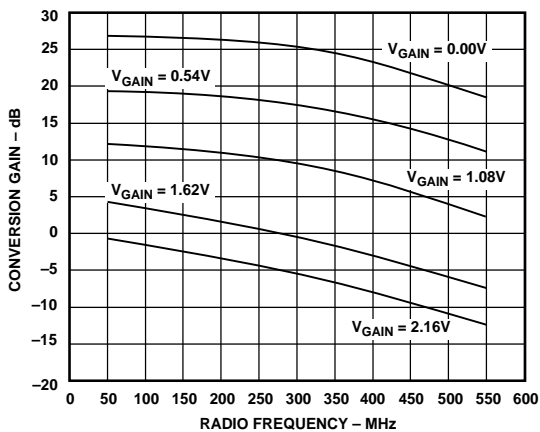

Figure 15. Mixer Conversion Gain vs. Frequency,  $T = +25^{\circ}\text{C}$ ,  $V_{\text{POS}} = 2.7\text{ V}$ ,  $V_{\text{REF}} = 1.35\text{ V}$ ,  $I_{\text{F}} = 10.7\text{ MHz}$

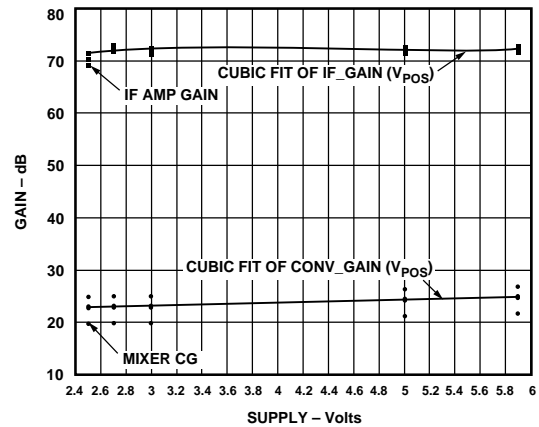

Figure 18. Mixer Conversion Gain and IF Amplifier Gain vs. Supply Voltage,  $T = +25^{\circ}\text{C}$ ,  $V_{\text{GAIN}} = 0.3\text{ V}$ ,  $V_{\text{REF}} = 1.5\text{ V}$ ,  $I_{\text{F}} = 10.7\text{ MHz}$ ,  $R_{\text{F}} = 250\text{ MHz}$

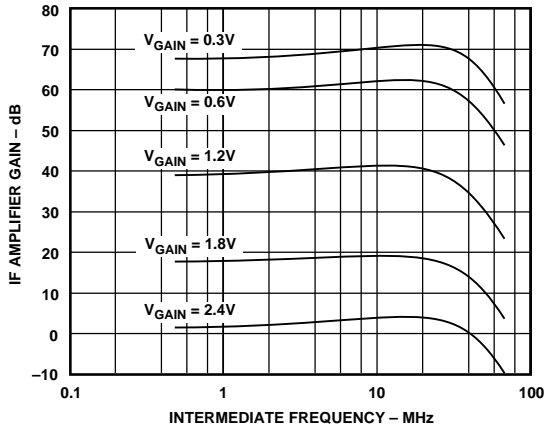

Figure 19. IF Amplifier Gain vs. Frequency,  $T = +25^{\circ}\text{C}$ ,  $V_{\text{POS}} = 3\text{ V}$ ,  $V_{\text{REF}} = 1.5\text{ V}$

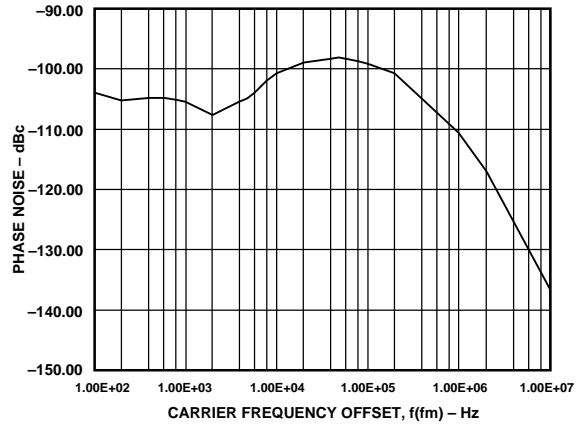

Figure 22. PLL Phase Noise  $L(F)$  vs. Frequency,  $V_{\text{POS}} = 3\text{ V}$ ,  $C_3 = 0.1\ \mu\text{F}$ ,  $IF = 10.7\text{ MHz}$

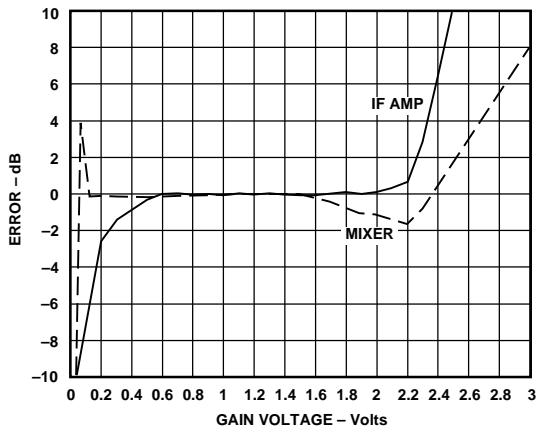

Figure 20. AD607 Gain Error vs. Gain Control Voltage, Representative Part

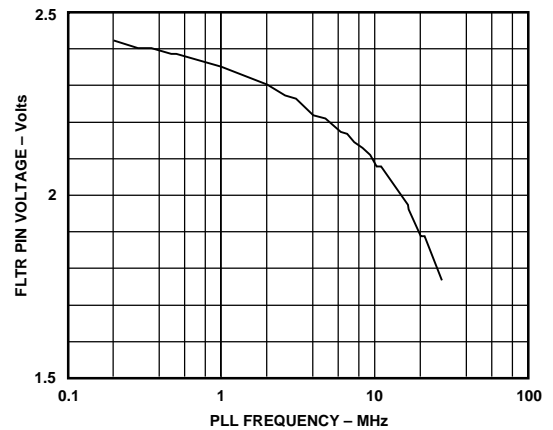
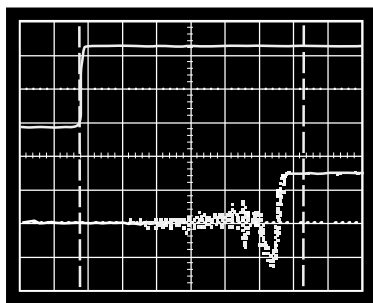

Figure 23. PLL Loop Voltage at FLTR ( $K_{VCO}$ ) vs. Frequency



996.200  $\mu\text{s}$  1.00870 ms 1.02120 ms  
 Timebase = 2.5  $\mu\text{s}/\text{div}$  Delay = 1.00870 ms  
 Memory 1 = 100.0 mVolts/div Offset = 127.3 mVolts  
 Timebase = 2.50  $\mu\text{s}/\text{div}$  Delay = 1.00870 ms  
 Memory 2 = 20.00 mVolts/div Offset = 155.2 mVolts  
 Timebase = 2.50  $\mu\text{s}/\text{div}$  Delay = 1.00870 ms  
 Delta T = 16.5199  $\mu\text{s}$   
 Start = 1.00048 ms Stop = 1.01700 ms  
 Trigger on External at Pos. Edge at 134.0 mVolts

Figure 21. PLL Acquisition Time

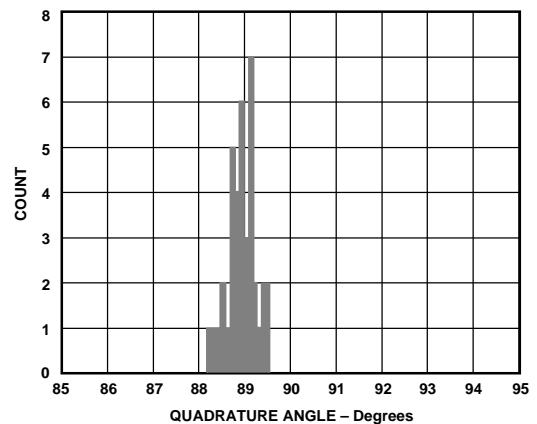

Figure 24. Demodulator Quadrature Angle, Histogram,  $T = +25^{\circ}\text{C}$ ,  $V_{\text{POS}} = 3\text{ V}$ ,  $IF = 10.7\text{ MHz}$

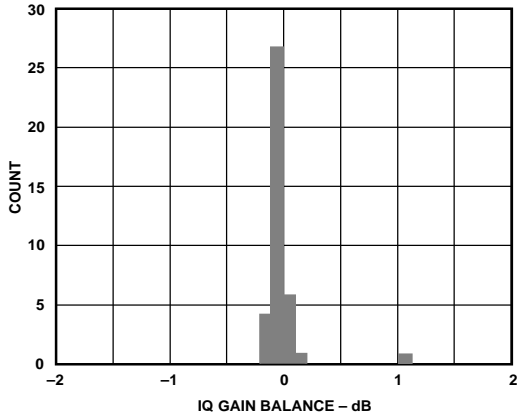

Figure 25. Demodulator Gain Balance, Histogram,  $T = +25^{\circ}\text{C}$ ,  $V_{\text{POS}} = 3\text{ V}$ ,  $IF = 10.7\text{ MHz}$

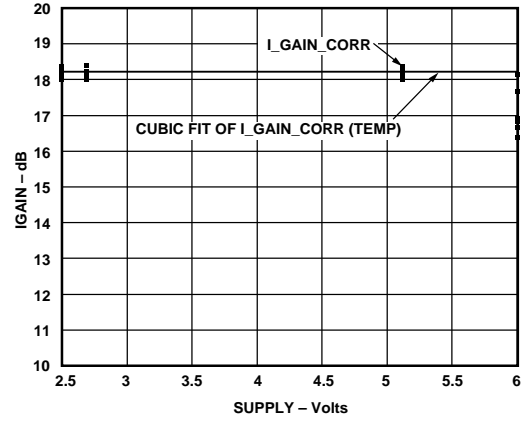

Figure 28. Demodulator Gain vs. Supply Voltage

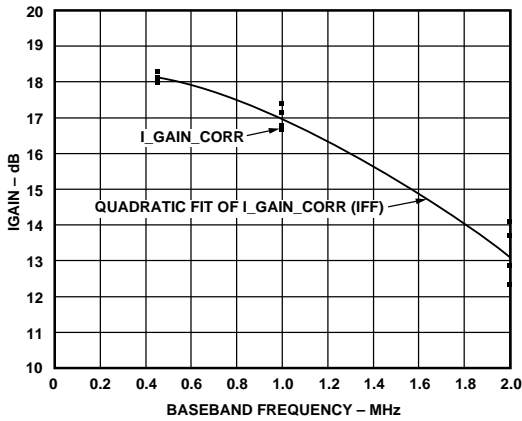

Figure 26. Demodulator Gain vs. Frequency

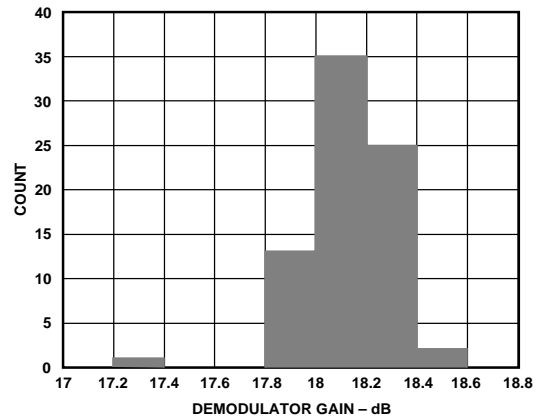

Figure 29. Demodulator Gain Histogram,  $T = +25^{\circ}\text{C}$ ,  $V_{\text{POS}} = 3\text{ V}$ ,  $IF = 10.7\text{ MHz}$

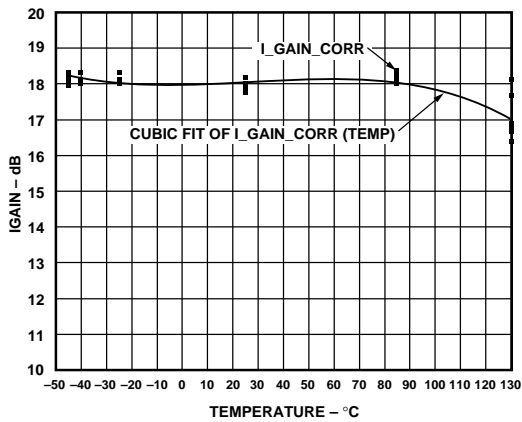

Figure 27. Demodulator Gain vs. Temperature

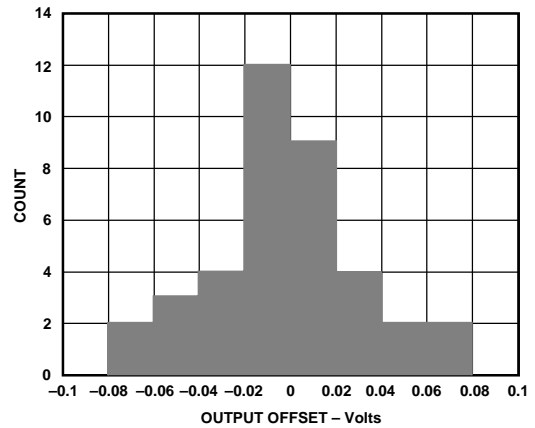
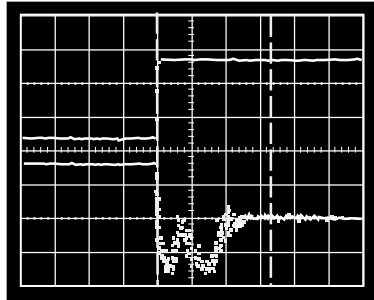

Figure 30. Demodulator Output Offset Voltage Histogram,  $T = +25^{\circ}\text{C}$ ,  $V_{\text{POS}} = 3\text{ V}$ ,  $IF = 10.7\text{ MHz}$



Timebase = 5.00  $\mu$ s/div      Delay = 40.2377 ms  
 Memory 1 = 100.0 mVolts/div      Offset = 154.0 mVolts  
 Timebase = 5.00  $\mu$ s/div      Delay = 40.2377 ms  
 Memory 2 = 60.00 mVolts/div      Offset = 209.0 mVolts  
 Timebase = 5.00  $\mu$ s/div      Delay = 40.2377 ms  
 Delta T = 15.7990  $\mu$ s  
 Start = 40.2327 ms      Stop = 40.2485 ms  
 Trigger on External at Pos. Edge at 40.0 mVolts

Figure 31. Power-Up Response Time to PLL Stable

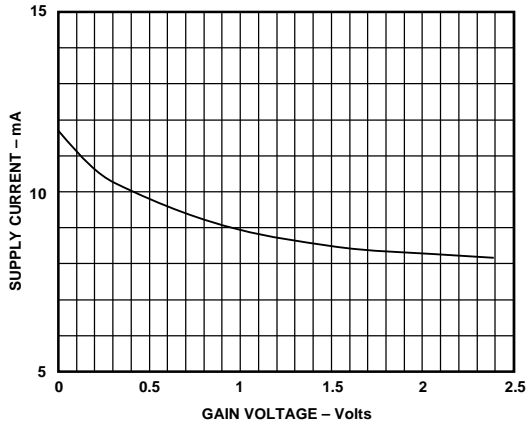

Figure 32. Power Supply Current vs. Gain Control Voltage, GREF = 1.5 V

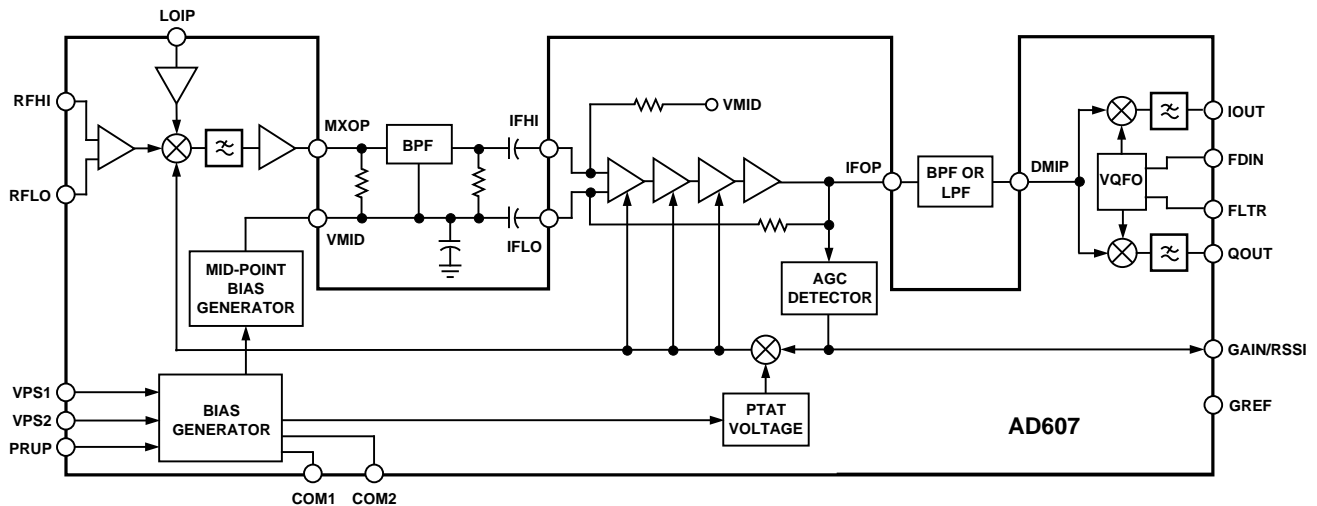

Figure 33. Functional Block Diagram

**PRODUCT OVERVIEW**

The AD607 provides most of the active circuitry required to realize a complete low power, single-conversion superheterodyne receiver, or most of a double-conversion receiver, at input frequencies up to 500 MHz, and with an IF of from 400 kHz to 12 MHz. The internal I/Q demodulators, and their associated phase locked-loop, which can provide carrier recovery from the IF, support a wide variety of modulation modes, including n-PSK, n-QAM, and AM. A single positive supply voltage of 3 V is required (2.7 V minimum, 5.5 V maximum) at a typical supply current of 8.5 mA at midgain. In the following discussion,  $V_P$  will be used to denote the power supply voltage, which will be assumed to be 3 V.

Figure 33 shows the main sections of the AD607. It consists of a variable-gain UHF mixer and linear four-stage IF strip, which together provide a voltage controlled gain range of more than 90 dB; followed by dual demodulators, each comprising a multiplier followed by a 2-pole, 2 MHz low-pass filter; and driven by a phase-locked loop providing the inphase and quadrature clocks. An internal AGC detector is included, and the temperature stable gain control system provides an accurate RSSI capability. A biasing system with CMOS compatible power-down completes the AD607.

**Mixer**

The UHF mixer is an improved Gilbert cell design, and can operate from low frequencies (it is internally dc-coupled) up to an RF input of 500 MHz. The dynamic range at the input of the mixer is determined, at the upper end, by the maximum input signal level of  $\pm 56$  mV between RFHI and RFLO up to which the mixer remains linear, and, at the lower end, by the noise level. It is customary to define the linearity of a mixer in terms of the 1 dB gain-compression point and third-order intercept, which for the AD607 are  $-15$  dBm and  $-8$  dBm, respectively, in a  $50 \Omega$  system.

# AD607

The mixer's RF input port is differential, that is, pin RFLO is functionally identical to RFHI, and these nodes are internally biased; we will generally assume that RFLO is decoupled to ac ground. The RF port can be modeled as a parallel RC circuit as shown in Figure 34.

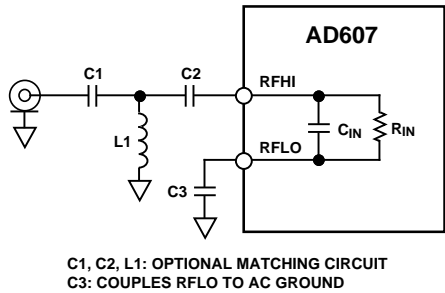

Figure 34. Mixer Port Modeled as a Parallel RC Network; an Optional Matching Network Is also Shown

The local oscillator (LO) input is internally biased at  $V_p/2$  via a nominal 1000  $\Omega$  resistor internally connected from pin LOIP to VMID. The LO interface includes a preamplifier which minimizes the drive requirements, thus simplifying the oscillator design and reducing LO leakage from the RF port. Internally, this single-sided input is actually differential; the noninverting input is referenced to pin VMID. The LO requires a single-sided drive of  $\pm 50$  mV, or  $-16$  dBm in a 50  $\Omega$  system.

The mixer's output passes through both a low-pass filter and a buffer, which provides an internal differential to single-ended signal conversion with a bandwidth of approximately 45 MHz. Its output at pin MXOP is in the form of a single-ended current. This approach eliminates the 6 dB voltage loss of the usual series termination by replacing it with shunt terminations at the both the input and the output of the filter. The nominal conversion gain is specified for operation into a total IF bandpass filter (BPF) load of 165  $\Omega$ , that is, a 330  $\Omega$  filter, doubly-terminated as shown in Figure 33. Note that these loads are connected to bias point VMID, which is always at the midpoint of the supply (that is,  $V_p/2$ ).

The conversion gain is measured between the mixer input and the input of this filter, and varies between 1.5 dB and 26.5 dB for a 165  $\Omega$  load impedance. Using filters of higher impedance, the conversion gain can always be maintained at its specified value or made even higher; for filters of lower impedance, of say  $Z_O$ , the conversion gain will be lowered by  $10 \log_{10}(165/Z_O)$ . Thus, the use of a 50  $\Omega$  filter will result in a conversion gain that is 5.2 dB lower. Figure 35 shows filter matching networks and Table I lists resistor values.

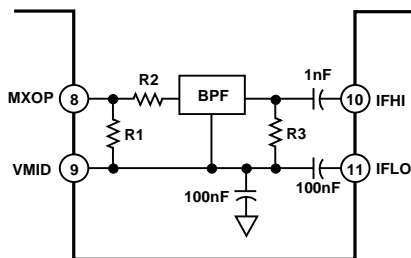

Figure 35. Suggested IF Filter Matching Network. The Values of R1 and R2 Are Selected to Keep the Impedance at Pin MXOP at 165  $\Omega$

Table I. AD607 Filter Termination Resistor Values for Common IFs

IF	Filter Impedance	Filter Termination Resistor Values <sup>1</sup> for 24 dB of Mixer Gain		
		R1	R2	R3
450 kHz	1500 $\Omega$	174 $\Omega$	1330 $\Omega$	1500 $\Omega$
455 kHz	1500 $\Omega$	174 $\Omega$	1330 $\Omega$	1500 $\Omega$
6.5 MHz	1000 $\Omega$	215 $\Omega$	787 $\Omega$	1000 $\Omega$
10.7 MHz	330 $\Omega$	330 $\Omega$	0 $\Omega$	330 $\Omega$

NOTES

<sup>1</sup>Resistor values were calculated such that  $R1 + R2 = Z_{FILTER}$  and  $R1 \parallel (R2 + Z_{FILTER}) = 165 \Omega$ .

The maximum permissible signal level at MXOP is determined by both voltage and current limitations. Using a 3 V supply and VMID at 1.5 V, the maximum swing is about  $\pm 1.3$  V. To attain a voltage swing of  $\pm 1$  V in the standard IF filter load of 165  $\Omega$  load requires a peak drive current of about  $\pm 6$  mA, which is well within the linear capability of the mixer. However, these upper limits for voltage and current should not be confused with issues related to the mixer gain, already discussed. In an operational system, the AGC voltage will determine the mixer gain, and hence the signal level at the IF input pin IFHI; it will always be less than  $\pm 56$  mV ( $-15$  dBm into 50  $\Omega$ ), which is the limit of the IF amplifier's linear range.

IF Amplifier

Most of the gain in the AD607 arises in the IF amplifier strip, which comprises four stages. The first three are fully differential and each has a gain span of 25 dB for the nominal AGC voltage range. Thus, in conjunction with the mixer's variable gain, the total gain exceeds 90 dB. The final IF stage has a fixed gain of 20 dB, and it also provides differential to single-ended conversion.

The IF input is differential, at IFHI (noninverting relative to the output IFOP) and IFLO (inverting). Figure 36 shows a simplified schematic of the IF interface. The offset voltage of this stage would cause a large dc output error at high gain, so it is nulled by a low-pass feedback path from the IF output, also shown in Figure 25. Unlike the mixer output, the signal at IFOP is a low-impedance single-sided voltage, centered at  $V_p/2$  by the DC feedback loop. It may be loaded by a resistance as low as 50  $\Omega$  which will normally be connected to VMID.

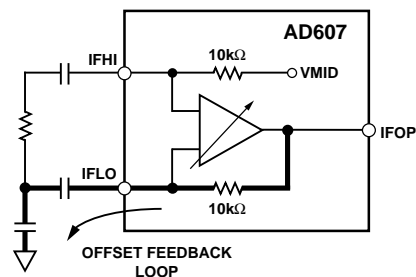
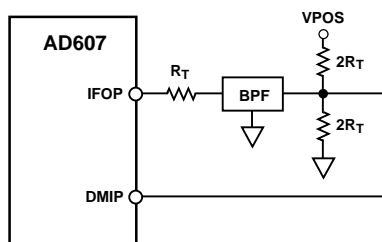

Figure 36. Simplified Schematic of the IF Interface

The IF's small-signal bandwidth is approximately 45 MHz from IFHI and IFLO through IFOP. The peak output at IFOP is  $\pm 560$  mV at  $V_P = 3$  V and  $\pm 400$  mV at the minimum  $V_P$  of 2.7 V. This allows some headroom at the demodulator inputs (pin DMIP), which accept a maximum input of  $\pm 150$  mV for  $IF_s > 3$  MHz and  $\pm 75$  mV for  $IF_s \leq 3$  MHz (at  $IF_s \leq 3$  MHz, the drive to the demodulators must be reduced to avoid saturating the output amplifiers with higher order mixing products that are no longer removed by the onboard low-pass filters).

If the internal AGC detector is used, the IF output will be at an amplitude of  $V_P/10$ , that is,  $\pm 300$  mV for  $V_P = 3$  V. This  $\pm 300$  mV level requires the insertion of 6 dB of post-IF filter loss between IFOP and DMIP to avoid overloading the demodulators; often, a simple RC low-pass filter with its corner frequency at the IF will suffice.

Since there is no band-limiting in the IF strip, the output-referred noise can be quite high; in a typical application and at a gain of 75 dB it is about 100 mV rms, making post-IF filtering desirable. IFOP may be also used as an IF output for driving an A/D converter, external demodulator, or external AGC detector. Figure 37 shows methods of matching the optional second IF filter.



a. Biasing DMIP from Power Supply (Assumes BPF AC Coupled Internally)

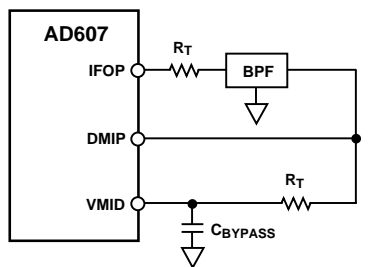

b. Biasing DMIP from VMID (Assumes BPF AC Coupled Internally)

Figure 37. Input and Output Matching of the Optional Second IF Filter

### Gain Scaling and RSSI

The AD607's overall gain, expressed in decibels, is linear-in-dB with respect to the AGC voltage  $V_G$  at pin GAIN/RSSI. The gain of all sections is maximum when  $V_G$  is zero, and reduces progressively up to  $V_G = 2.2$  V (for  $V_P = 3$  V; in general, up to a limit  $V_P - 0.8$  V). The gain of all stages changes in parallel. The AD607 features temperature-compensation of the gain scaling. Note that GAIN/RSSI pin is either an MGC input, when the gain is controlled by some external means, or an RSSI output, when the internal AGC detector is used.

The gain control scaling is proportional to the reference voltage applied to the pin GREF. When this pin is tied to the midpoint of the supply ( $V_{MID}$ ), the scale is nominally 20 mV/dB (50 dB/V) for  $V_P = 3$  V. Under these conditions, the lower 80 dB of gain range (mixer plus IF) corresponds to a control voltage of  $0.4$  V  $\leq V_G \leq 2.0$  V. The final centering of this 1.6 V range depends on the insertion losses of the IF filters used. More generally, the gain scaling using these connections is  $V_P/150$  (volts per dB), so becomes 33.3 mV/dB (30 dB/V) using a 5 V supply, with a proportional change in the AGC range, to  $0.33$  V  $\leq V_G \leq 3$  V, Table II lists gain control voltages and scale factors for power supply voltages from 2.7 V to 5.5 V.

Alternatively, pin GREF can be tied to an external voltage reference,  $V_R$ , provided, for example, by an AD1582 (2.5 V) or AD1580 (1.21 V) voltage reference, to provide supply-independent gain scaling of  $V_R/75$  (volts per dB). When using the Analog Devices' AD7013 and AD7015 baseband converters, the external reference may also be provided by the reference output of the baseband converter (Figure 38). For example, the AD7015 baseband converter provides a  $V_R$  of 1.23 V; when connected to GREF the gain scaling is 16.4 mV/dB (60 dB/V). An auxiliary DAC in the AD7015 can be used to generate the MGC voltage. Since it uses the same reference voltage, the numerical input to this DAC provides an accurate RSSI value in digital form, no longer requiring the reference voltage to have high absolute accuracy.

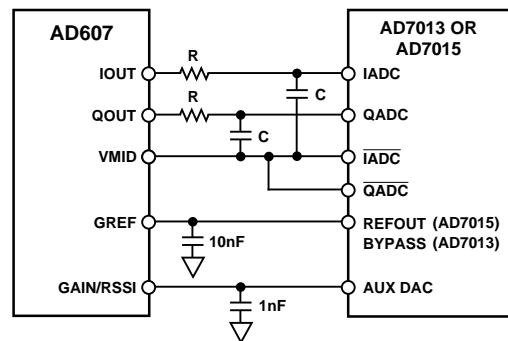

Figure 38. Interfacing the AD607 to the AD7013 or AD7015 Baseband Converters

### I/Q Demodulators

Both demodulators (I and Q) receive their inputs at pin DMIP. Internally, this single-sided input is actually differential; the noninverting input is referenced to pin VMID. Each demodulator comprises a full-wave synchronous detector followed by a 2 MHz, two-pole low-pass filter, producing single-sided outputs at pins IOUT and QOUT. Using the I and Q demodulators for IFs above 12 MHz is precluded by the 400 kHz to 12 MHz response of the PLL used in the demodulator section. Pin DMIP requires an external bias source at  $V_P/2$ ; Figure 39 shows suggested methods.

Outputs IOUT and QOUT are centered at  $V_P/2$  and can swing up to  $\pm 1.23$  V even at the low supply voltage of 2.7 V. They can therefore directly drive the RX ADCs in the AD7015 baseband converter, which require an amplitude of 1.23 V to fully load them when driven by a single-sided signal. The conversion gain of the I and Q demodulators is 18 dB (X8), requiring a maximum input amplitude at DMIP of  $\pm 150$  mV for  $IF_s > 3$  MHz.

# AD607

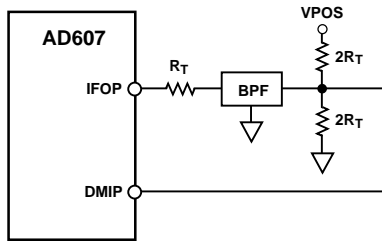

a. Biasing DMIP from Power Supply (Assumes BPF AC Coupled Internally)

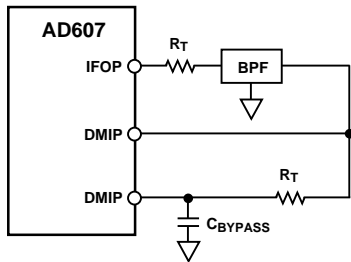

b. Biasing DMIP from VMID (Assumes BPF AC Coupled Internally)

Figure 39. Suggested Methods for Biasing Pin DMIP at  $V_P/2$

For IFs < 3 MHz, the on-chip low-pass filters (2 MHz cutoff) do not attenuate the IF or feedthrough products; thus, the maximum input voltage at DMIP must be limited to  $\pm 75$  mV to allow sufficient headroom at the I and Q outputs for not only the desired baseband signal but also the unattenuated higher-order demodulation products. These products can be removed by an external low-pass filter. In the case of IS54 applications using a 455 kHz IF and the AD7013 baseband converter, a simple 1-pole RC filter with its corner above the modulation bandwidth is sufficient to attenuate undesired outputs.

## Phase-Locked Loop

The demodulators are driven by quadrature signals that are provided by a variable frequency quadrature oscillator (VFQO), phase locked to a reference signal applied to pin FDIN. When this signal is at the IF, inphase and quadrature baseband outputs are generated at IOUT and QOUT, respectively. The

quadrature accuracy of this VFQO is typically  $-1.2^\circ$  at 10.7 MHz. The PLL uses a sequential-phase detector that comprises low power emitter-coupled logic and a charge pump (Figure 40).

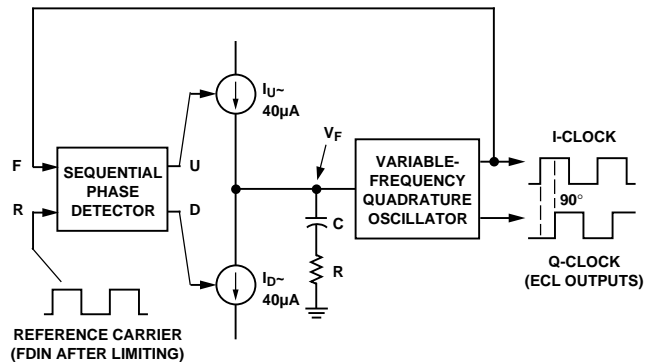

Figure 40. Simplified Schematic of the PLL and Quadrature VCO

The reference signal may be provided from an external source, in the form of a high-level clock, typically a low level signal ( $\pm 400$  mV) since there is an input amplifier between FDIN and the loop's phase detector. For example, the IF output itself can be used by connecting DMIP to FDIN, which will then provide automatic carrier recover for synchronous AM detection and take advantage of any post-IF filtering. Pin FDIN must be biased at  $V_P/2$ ; Figure 41 shows suggested methods.

The VFQO operates from 400 kHz to 12 MHz and is controlled by the voltage between VPOS and FLTR. In normal operation, a series RC network, forming the PLL loop filter, is connected from FLTR to ground. The use of an integral sample-hold system ensures that the frequency-control voltage on pin FLTR remains held during power-down, so reacquisition of the carrier typically occurs in 16.5  $\mu$ s.

In practice, the probability of a phase mismatch at power-up is high, so the worst-case linear settling period to full lock needs to be considered in making filter choices. This is typically 16.5  $\mu$ s at an IF of 10.7 MHz for a  $\pm 100$  mV signal at DMIP and FDIN.

Table II. AD607 Gain and Manual Gain Control Voltage vs. Power Supply Voltage

Power Supply Voltage (V)	GREF (= VMID) (V)	Scale Factor (dB/V)	Scale Factor (mV/dB)	Gain Control Voltage Input Range (V)
2.7	1.35	55.56	18.00	0.360–1.800
3.0	1.5	50.00	20.00	0.400–2.000
3.5	1.75	42.86	23.33	0.467–2.333
4.0	2.0	37.50	26.67	0.533–2.667
4.5	2.25	33.33	30.00	0.600–3.000
5.0	2.5	30.00	33.33	0.667–3.333
5.5	2.75	27.27	36.67	0.733–3.667

## NOTE

Maximum gain occurs for gain control voltage = 0 V.

## Bias System

The AD607 operates from a single supply,  $V_P$ , usually of 3 V, at a typical supply current of 8.5 mA at midgain and  $T = 27^\circ\text{C}$ , corresponding to a power consumption of 25 mW. Any voltage from 2.7 V to 5.5 V may be used.

The bias system includes a fast-acting active-high CMOS-compatible power-up switch, allowing the part to idle at 550  $\mu\text{A}$  when disabled. Biasing is proportional-to-absolute-temperature (PTAT) to ensure stable gain with temperature.

An independent regulator generates a voltage at the midpoint of the supply ( $V_P/2$ ) which appears at the VMID pin, at a low impedance. This voltage does not shut down, ensuring that the major signal interfaces (e.g., mixer-to-IF and IF-to-demodulators) remain biased at all times, thus minimizing transient disturbances at power-up and allowing the use of substantial decoupling capacitors on this node. The quiescent consumption of this regulator is included in the idling current.

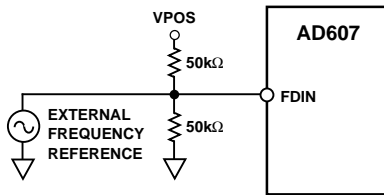

a. Biasing FDIN from Supply when Using External Frequency Reference

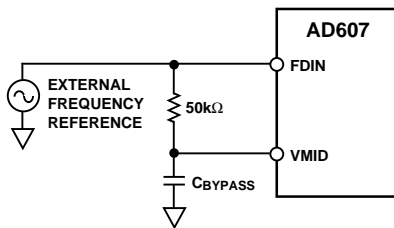

b. Biasing FDIN from VMID when Using External Frequency Reference

Figure 41. Suggested Methods for Biasing Pin FDIN at  $V_P/2$

## USING THE AD607

In this section, we will focus on a few areas of special importance and include a few general application tips. As is true of any wideband high gain component, great care is needed in PC board layout. The location of the particular grounding points must be considered with due regard to possibility of unwanted signal coupling, particularly from IFOP to RFHI or IFHI or both.

The high sensitivity of the AD607 leads to the possibility that unwanted local EM signals may have an effect on the performance. During system development, carefully-shielded test assemblies should be used. The best solution is to use a fully-enclosed box enclosing all components, with the minimum number of needed signal connectors (RF, LO, I and Q outputs) in miniature coax form.

The I and Q output leads can include small series resistors (about 100  $\Omega$ ) inside the shielded box without significant loss of performance, provided the external loading during testing is light (that is, a resistive load of more than 20 k $\Omega$  and capacitances of a few picofarads). These help to keep unwanted RF emanations out of the interior.

The power supply should be connected via a through-hole capacitor with a ferrite bead on both inside and outside leads. Close to the IC pins, two capacitors of different value should be used to decouple the main supply ( $V_P$ ) and the midpoint supply pin, VMID. Guidance on these matters is also generally included in applications schematics.

## Gain Distribution

As in all receivers, the most critical decisions in effectively using the AD607 relate to the partitioning of gain between the various subsections (Mixer, IF Amplifier, Demodulators) and the placement of filters, so as to achieve the highest overall signal-to-noise ratio and lowest intermodulation distortion.

Figure 42 shows the main RF/IF signal path at maximum and minimum signal levels.

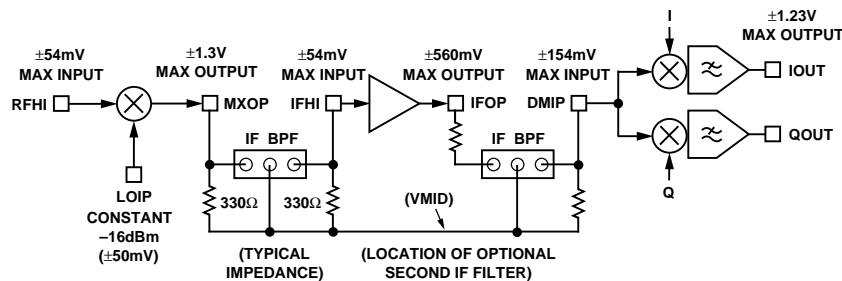

Figure 42. Signal Levels for Minimum and Maximum Gain

# AD607

As noted earlier, the gain in dB is reduced linearly with the voltage  $V_G$  on the GAIN pin. Figure 43 shows how the mixer and IF strip gains vary with  $V_G$  when GREF is connected to VMID (1.5 V) and a supply voltage of 3 V is used. Figure 44 shows how these vary when GREF is connected to a 1.23 V reference.

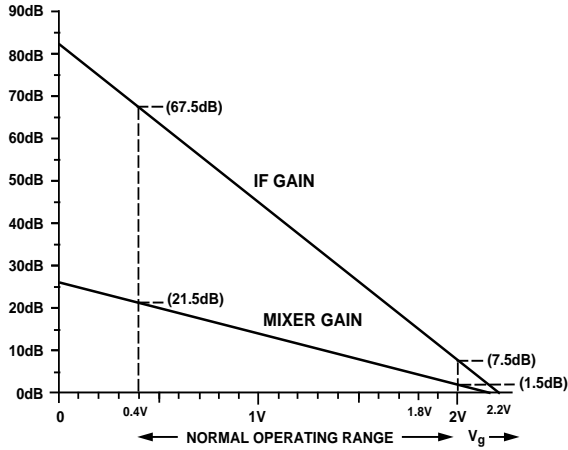

Figure 43. Gain Distribution for GREF = 1.5 V

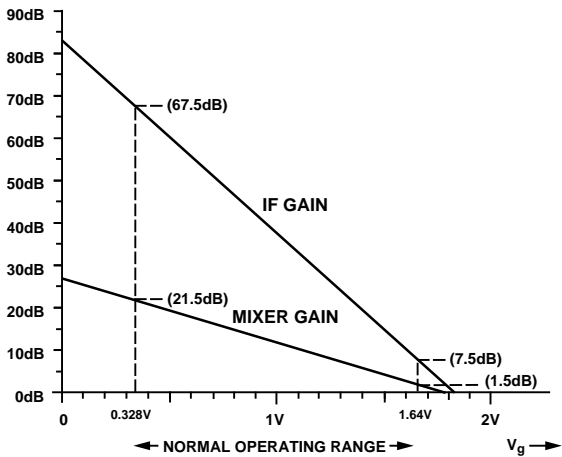

Figure 44. Gain Distribution for GREF = 1.23 V

## Using the Internal AGC Detector

The AD607 includes a detector cell at the output of the IF amplifier that allows it to provide its own AGC and output-leveling function in receiver applications where DSP support is not needed. It is only necessary to connect a filter capacitor between the GAIN pin and ground to invoke this feature. The voltage appearing on this pin may then be used as an RSSI output, with the scaling discussed earlier; note particularly that the voltage on GREF continues to determine this scaling.

Figure 45 shows a simplified schematic of the detector. Transistor Q2 remains cut off by a 300 mV bias (when  $V_P = 3$  V; in general,  $\approx V_P/10$ ) until the positive tip of the IF waveform causes it to briefly conduct, charging the AGC filter capacitor  $C_{AGC}$  in a positive direction. The voltage across this capacitor is  $V_G$ .

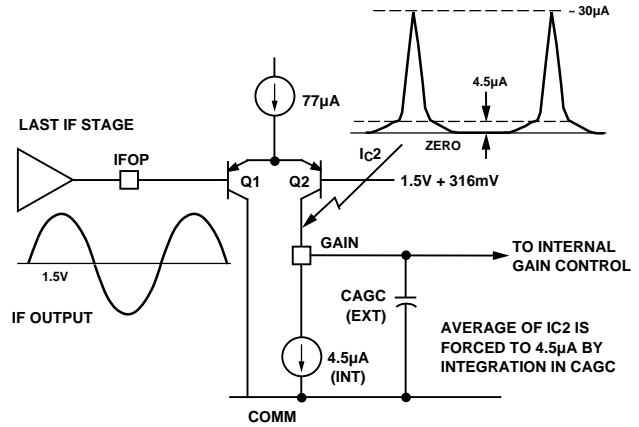

Figure 45. Simplified Schematic of AGC Detector

Acting against this is an internally generated 4.5  $\mu$ A pull-down current, which operates to within a few millivolts of ground. As  $V_G$ , the voltage at the GAIN/RSSI pin, rises, the gain falls, so reducing the amplitude of the IF output and reducing the amplitude of the current spike in Q2; eventually a point is reached where its average collector current is balanced by the pull-down current, and the charging ceases. It will be apparent that the loop filter is essentially a perfect integrator.

This simple system can be used because the input impedance of the gain-control system, also internally tied to the GAIN/RSSI pin, is several megohms, and its bias current is small. The voltage  $V_G$  may be used as an RSSI output; however, if it is to be heavily loaded, a buffer amplifier must be used.

Note that, unlike a post-demodulation AGC detector (via DSP), this scheme responds to signal plus noise. Thus, when operating at high gains, the AGC loop will “see” a substantial output at the IFOP node, even though a filter may be added by the user between the pins IFOP and DMIP. This will trick the loop into lowering the gain until the composite output signal (IF plus noise) reaches the reference level and satisfies the average-current requirement. In these circumstances, the wanted signal will be smaller than expected. Thus, the internal AGC system will result in a slight compression of the demodulated output for very small signal levels.

## AGC Discharge Time

The discharge current is approximately 4.5  $\mu$ A; thus, to restore gain in the event of a rapid drop-out requires a time of  $T = C \times V_G / 4.5 \mu\text{A}$ . Using a 1 nF capacitor, and noting that an 80 dB gain change corresponds to 1.6 V, the discharge time is 355  $\mu$ s. Note, however, that when GREF is tied to a different value, the scaling changes. For GREF = 1.23 V, the scale factor is 16.4 mV/dB, 80 dB corresponds to a 1.312 V change, and the discharge time decreases to 290  $\mu$ s.

$V_G$  could also be expressed in dB: with a scaling of 20 mV/dB, it works out to  $T = C \times P \times 44,000$ , where P is the change in input power, expressed in dB. Thus, using  $C = 1$  nF, checking the time needed for 80 dB we get  $T = 355 \mu\text{s}$ . For the case where the scaling is 16.4 mV/dB,  $T = C \times P \times 36,000$ .

The AD607’s AGC detector delivers only one brief charging pulse per cycle of the IF. At a 10.7 MHz IF, for example, this is every 93 ns. When the AGC system is in equilibrium, this pulse

of current exactly balances the 4.5  $\mu\text{A}$  discharge current. (It makes no difference what the actual value of  $V_G$  is at that point, since the AGC filter is an integrator.)

Thus, at 20 mV/dB

$$V_{\text{RIPPLE}} = \frac{IT}{C} = \frac{4.5 \mu\text{A} \times 93 \text{ ns}}{1 \text{ nF}} = 0.42 \text{ mV}$$

This corresponds to 0.021 dB, and the ripple will modulate the gain by that amount over each cycle. The effect of such modulation on the signal is hard to quantify, but it roughly translates to a 2% amplitude modulation. Also, the gain ripple depends on the scale factor. For this example, at  $G_{\text{REF}} = 1.23 \text{ V}$  and a 16.4 mV/dB scale factor, the gain ripple increases to 0.025 dB.

**AGC Charge Time**

When the gain is too high, the IF amplifier will be overdriven to produce a square wave output (roughly) of  $\pm 560 \text{ mV}$ . If perfectly square and time- and amplitude-symmetric, this would be sliced at the 300 mV level to generate a current of 76  $\mu\text{A}/2$ , or 38  $\mu\text{A}$ . After subtracting the 4.5  $\mu\text{A}$ , we should have about 33  $\mu\text{A}$ .

In fact, the maximum ramp-up current is about 20  $\mu\text{A}$ , because the waveform is not a crisp square wave (and as the loop approaches equilibrium it is more nearly sinusoidal). Thus, the ramp-up rate is  $20/4.5 = 4.4$  times faster than the discharge rate. In our example, a 1.6 V change will require about 1.5 ms using  $C = 1 \text{ nF}$ .

**Applications Hints**

Do not place a resistor from Pin 12 to Ground: The resistor converts the integrator—ideal for AGC—into a low-pass filter. An integrator needs no input to sustain a given output; a low-

pass filter does. This “input” is an INCREASED AMPLITUDE required at IFOP. The AGC loop thus does not level the output at IFOP.

**Reasons for Using a Larger AGC Capacitor**

1. In applications where gain modulation may be troublesome, raise the capacitor from 1 nF to 2.7 nF; the 80 dB slew time (at 20 mV/dB) is now close to 1 ms.
2. As the IF is lowered, the capacitor must be increased accordingly if gain ripple is to be avoided. Thus, to achieve the same ripple at 455 kHz requires the 1 nF capacitor to be increased to 0.022  $\mu\text{F}$ .
3. In AM applications, the AGC loop must not track the modulation envelope. The objective should be that the gain should not vary by more than the amount required to introduce, say, 1% THD distortion at the lowest modulation frequency, say, 300 Hz. Note that in AM applications it is the modulation bandwidth that determines the required AGC filter capacitor, not the IF.
4. In some applications, even slower AGC may be desired than that required to prevent modulation tracking.

**AD607 EVALUATION BOARD**

The AD607 evaluation board (Figures 46 and 47) consists of an AD607, ground plane, I/O connectors, and a 10.7 MHz band-pass filter. The RF and LO ports are terminated in 50  $\Omega$  to provide a broadband match to external signal generators to allow a choice of RF and LO input frequencies. The IF filter is at 10.7 MHz and has 330  $\Omega$  input and output terminations; the board is laid out to allow the user to substitute other filters for other IFs.

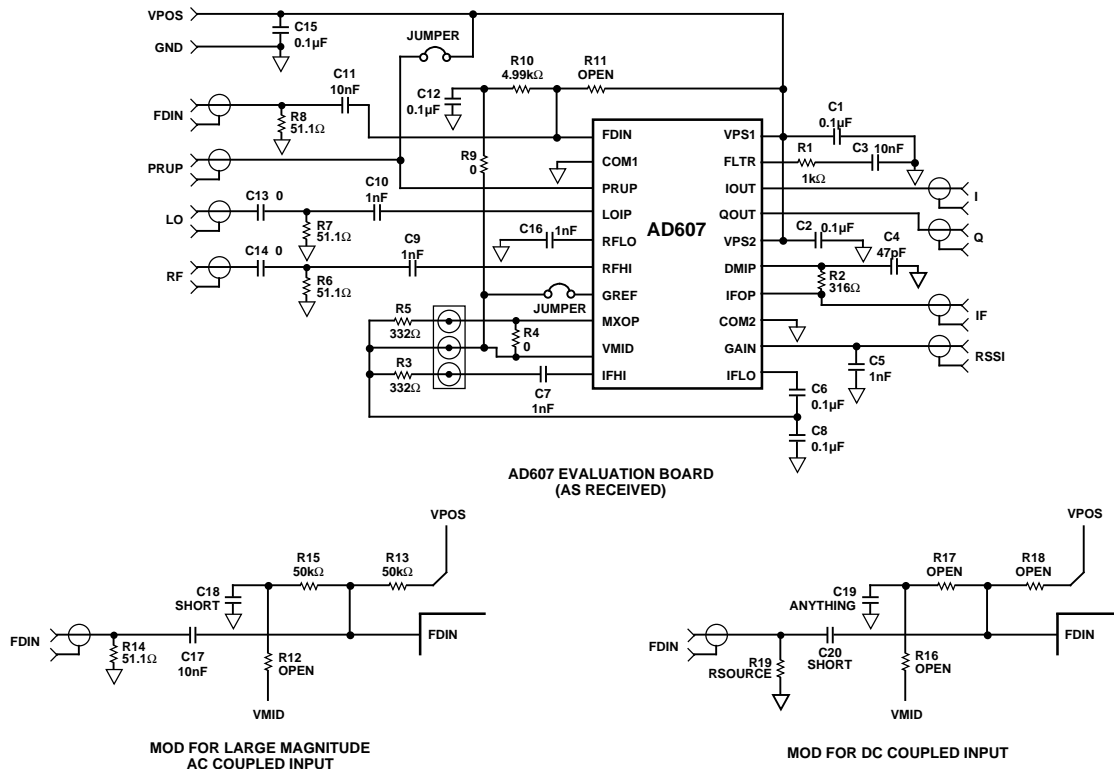

Figure 46. Evaluation Board

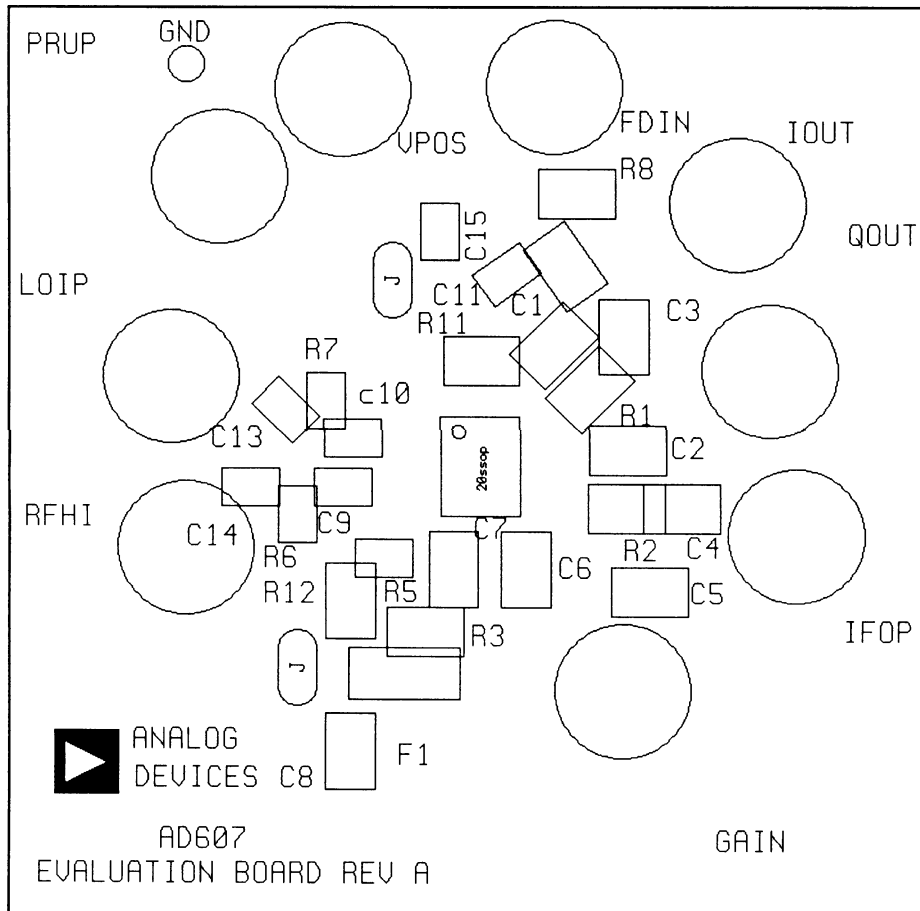

Figure 47. Evaluation Board Layout

The board provides SMA connectors for the RF and LO port inputs, the demodulated I and Q outputs, the manual gain control (MGC) input, the PLL input, and the power-up input. In addition, the IF output is also available at an SMA connector;

this may be connected to the PLL input for carrier recovery to realize synchronous AM and FM detection via the I and Q demodulators, respectively. Table III lists the AD607 Evaluation Board's I/O Connectors and their functions.

**Table III. AD607 Evaluation Board Input and Output Connections**

Reference Designation	Connector Type	Description	Coupling	Approximate Signal Level	Comments
J1	SMA	Frequency Detector Input	DC	$\pm 400$ mV	This pin needs to be biased at VMID and ac coupled when driven by an external signal generator.
J2	SMA	Power Up	DC	CMOS Logic Level Input	Tied to Positive Supply by Jumper J10.
J3	SMA	LO Input	AC	-16 dBm ( $\pm 50$ mV)	Input is terminated in 50 $\Omega$ .
J4	SMA	RF Input	AC	-15 dBm max ( $\pm 54$ mV)	Input is terminated in 50 $\Omega$ .
J5	SMA	MGC Input or RSSI Output	DC	0.4 V to 2.0 V (3 V Supply) (GREF = VMID)	Jumper is set for Manual Gain Control Input; See Table I for Control Voltage Values.
J6	SMA	IF Output	AC	NA	This signal level depends on the AD607's gain setting.
J7	SMA	Q Output	AC	NA	This signal level depends on the AD607's gain setting.
J8	SMA	I Output	AC	NA	This signal level depends on the AD607's gain setting.
J9	Jumper	Ties GREF to VMID	NA	NA	Sets gain-control Scale Factor (SF); SF = 75/VMID in dB/V, where VMID = VPOS/2.
J10	Jumper	Ties Power-Up to Positive Supply	NA	NA	Remove to test Power Up/Down.
T1	Terminal Pin	Power Supply Positive Input (VPS1, VPS2)	DC	DC	2.7 V to 5.5 V Draws 8.5 mA at midgain connection.
T2	Terminal Pin	Power Supply Return (GND)	DC	0 V	

# AD607

In operation (Figure 48), the AD607 evaluation board draws about 8.5 mA at midgain (59 dB). Use high impedance probes to monitor signals from the demodulated I and Q outputs and the IF output. The MGC voltage should be set such that the signal level at DMIP does not exceed  $\pm 150$  mV; signal levels above this will overload the I and Q demodulators. The insertion loss between IFOP and DMIP is typically 3 dB if a simple low-pass filter (R8 and C2) is used and higher if a reverse-terminated bandpass filter is used.

If the AD607's internal AGC detector is used, then the GAIN/RSSI (Pin 12) becomes an output and the RSSI voltage appears across C12, which serves as an integrating capacitor. This voltage must be monitored by a high impedance (100 k $\Omega$  minimum) probe. The internal AGC loop holds the IF voltage at IFOP (Pin 14) at  $\pm 300$  mV; in this application, about 6 dB of attenuation is needed between pins IFOP and DMIP to avoid overloading the I and Q demodulators.

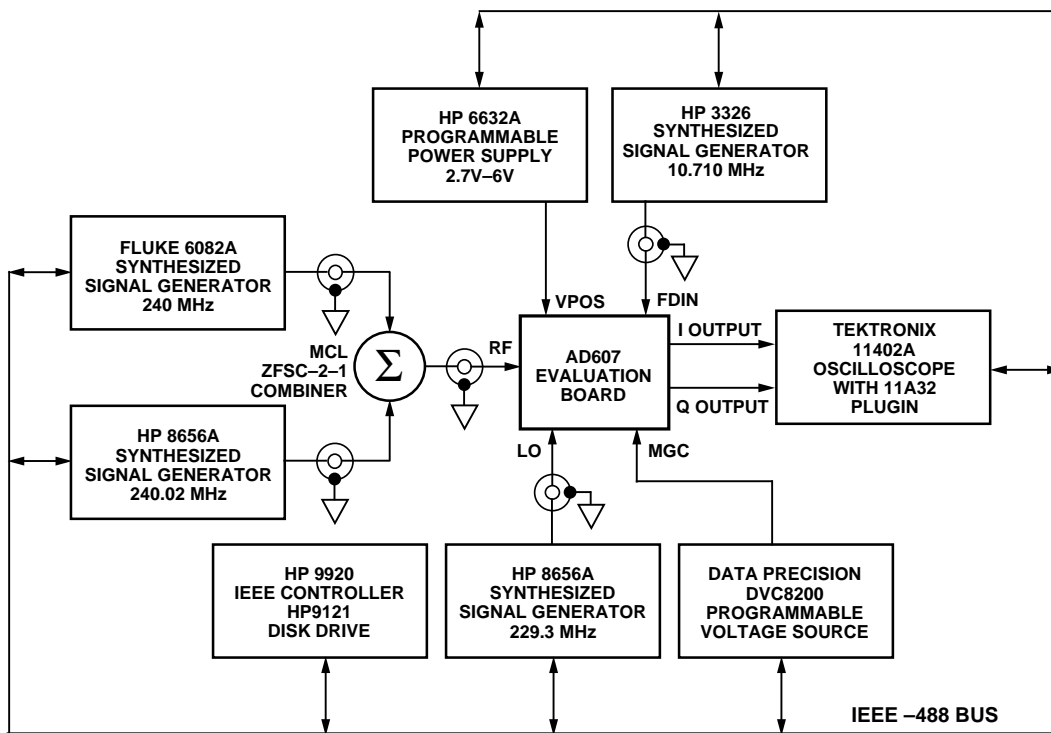
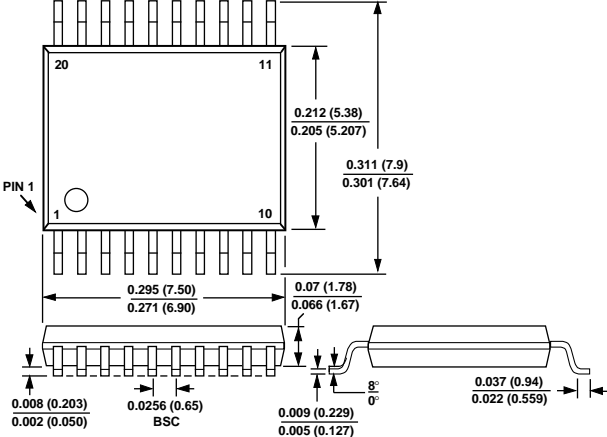

Figure 48. Evaluation Board Test Setup

**OUTLINE DIMENSIONS**

Dimensions shown in inches and (mm).

**20-Pin Plastic SSOP (RS-20)**



- 1. LEAD NO. 1 IDENTIFIED BY A DOT.
- 2. LEADS WILL BE EITHER TIN PLATED OR SOLDER DIPPED IN ACCORDANCE WITH MIL-M-38510 REQUIREMENTS





LittleDiode supplies new, hard to find or obsolete electronic components and semiconductors all over the world.

With over two million different components listed you are sure to find the part you need.

Feel free to visit us today at our online store:

[LittleDiode.com](http://LittleDiode.com)

Looking forward to providing you with the best possible service.