

FEATURES

Fully Compliant with IS98A and PCS Specifications

Linear IF Amplifier

-63 dB to +34 dB

Linear-in-dB Gain Control

Temperature-Compensated Gain Control

Quadrature Modulator

Modulates IFs from 50 MHz to 350 MHz

Integral Low Dropout Regulator

Accepts 2.9 V to 4.2 V Input from Battery

Low Power

10.4 mA at Midgain

<10 μ A Sleep Mode Operation

Companion Receiver IF Chip Available (AD6121)

APPLICATIONS

CDMA, W-CDMA, AMPS and TACS Operation

QPSK Transmitters

GENERAL DESCRIPTION

The AD6122 is a low power IF transmitter subsystem, specifically designed for CDMA applications. It consists of an I and Q modulator, a divide-by-two quadrature generator, high dynamic

range IF amplifiers with voltage-controlled gain and a power-down control input. An integral low dropout regulator allows operation from battery voltages from 2.9 V to 4.2 V.

The gain control input accepts an external gain control voltage input from a DAC. It provides 97 dB of gain control with a nominal 75 dB/V scale factor. Either an internal or an external reference may be used to set the gain-control scale factor.

The I and Q modulator accepts differential quadrature baseband inputs from a CDMA baseband converter. The local oscillator is injected at twice the IF frequency. A divide-by-two quadrature generator followed by dual polyphase filters ensures $\pm 1^\circ$ quadrature accuracy.

The modulator provides a common-mode reference output to bias the transmit DACs in the baseband converter to the same common-mode voltage as the modulator inputs, allowing dc coupling between the two ICs and thus eliminating the need to charge and discharge coupling capacitors. This allows the fastest power-up and power-down times for the AD6122 and CDMA baseband ICs.

The AD6122 is fabricated using a 25 GHz f_t silicon BiCMOS process and is packaged in a 28-lead SSOP and a 32-leadless LPMC chip scale package (5 mm \times 5 mm).

FUNCTIONAL BLOCK DIAGRAM

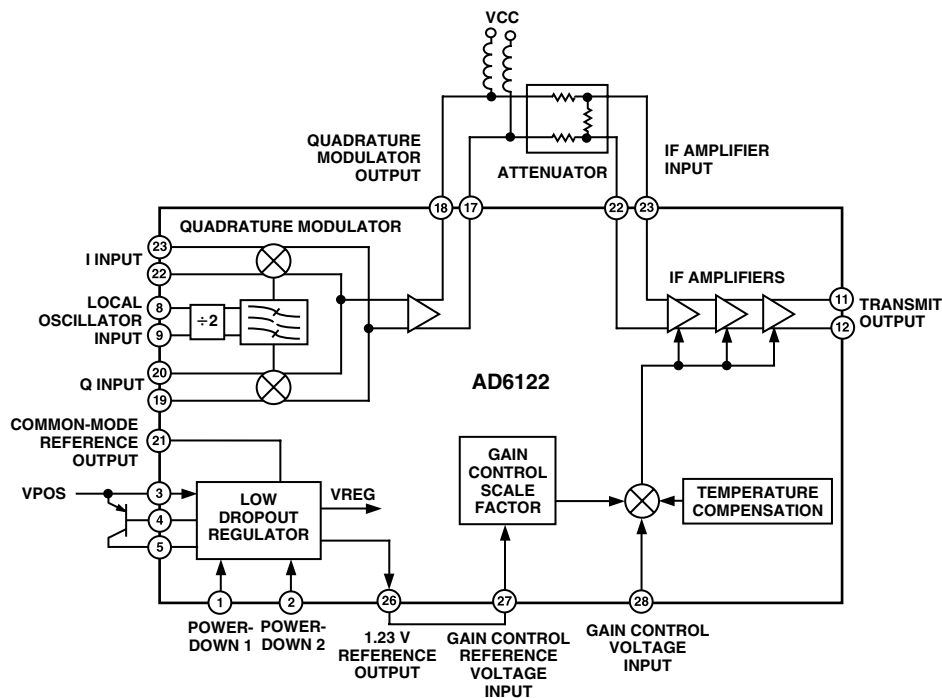

REV. B

Information furnished by Analog Devices is believed to be accurate and reliable. However, no responsibility is assumed by Analog Devices for its use, nor for any infringements of patents or other rights of third parties which may result from its use. No license is granted by implication or otherwise under any patent or patent rights of Analog Devices.

AD6122—SPECIFICATIONS

($T_A = +25^\circ\text{C}$, $V_{CC} = +3.0\text{ V}$, $L_O = 2 \times I_F$, $REFIN = 1.23\text{ V}$, LDO Enabled, unless otherwise noted) NOTE: All powers shown in dBm are referred to 1 k Ω .

Specification	Conditions	Min	Typ	Max	Unit
MODULATOR	LO = 260.76 MHz ($2 \times I_F$), 100 mV p-p 500 mV p-p Differential I and Q Inputs; Output Level Referred to a 1 k Ω Differential Load				
Output Level			-21		dBm
Output Third Order Harmonic			-50		dBc
I/Q Inputs					
Differential Input Voltage	Differential		500		mV p-p
Bandwidth	-3 dB	20			MHz
Resistance			30		k Ω
Quadrature Accuracy			± 1		$^\circ$
Amplitude Balance			± 0.1		dB
Output Referred Noise	0.9 MHz to 5.0 MHz Offsets		-169		dBm/Hz
Modulator Common-Mode Reference			1.408		V
LO Input Resistance	Differential Input at 260.38 MHz		1.2		k Ω
LO Input Capacitance	Differential Input at 260.38 MHz		2.4		pF
LO Carrier Leakage	Bias I/Q Using MODCMREF		-40		dBc
IF AMPLIFIER	$F_{IF} = 130.38\text{ MHz}$ VGAIN = 2.5 V, 1 k Ω Differential Load		10		dB
Noise Figure	VGAIN = 2.5 V		-32		dBm
Input 1 dB Compression Point	VGAIN = 2.5 V		-24		dBm
Input Third-Order Intercept	IF $\pm 630\text{ kHz}$		± 0.25		dB
Gain Flatness	Shunt Equivalent Model at 130.38 MHz		2.3		pF
Input Capacitance	Shunt Equivalent Model at 130.38 MHz		680		Ω
Differential IF Input Resistance	Per Pin at 130.38 MHz		4.2		k Ω
Differential IF Output Resistance	Per Pin at 130.38 MHz		2.0		pF
Differential IF Output Capacitance					
GAIN CONTROL INTERFACE					
Gain Scaling	Using Internal Reference		75		dB/V
Gain Scaling Linearity	For a Typical Dynamic Range of 92 dB		± 3		dB/V
Minimum Gain	VGAIN = 0.5 V		-63		dB
Maximum Gain	VGAIN = 2.5 V		+34		dB
Gain Control Response Time	90 dB Gain Change, Min Gain to Max Gain		0.7		μs
Input Resistance at REFIN			10		M Ω
Input Resistance at VGAIN			109		k Ω
POWER-DOWN INTERFACE					
Logic Threshold High	Power-Up on Logical High		1.34		V
Logic Threshold Low			1.30		V
Input Current for Logical High			0.1		μA
Turn-On Response Time	Measure to Settling of AGC from Standby Mode		23		μs
Turn-Off Response Time	To 200 μA Supply Current		187		ns
LOW DROPOUT REGULATOR	External PNP Pass Transistor, $V_{CE_{SAT}} = -0.4\text{ V}$ Max, $h_{FE} = 100/300\text{ Min/Max}$				
Input Range			2.9–4.2		V
Nominal Output			2.70		V
Dropout Voltage			200		mV
Reference Output			1.23		V
POWER SUPPLY					
Supply Range Bypassing Internal LDO			2.7–5.0		V
Supply Current	VGAIN = 1.5 V (Unity Gain)		10.4		mA
Standby Current			7.8		μA
OPERATING TEMPERATURE					
T_{MIN} to T_{MAX}		-40		+85	$^\circ\text{C}$

Specifications subject to change without notice.

ABSOLUTE MAXIMUM RATINGS¹

Supply Voltage DVCC, IFVCC, TXVCC to DGND,
 IFGND +5 V
 Internal Power Dissipation² 600 mW
 Operating Temperature Range -40°C to +85°C
 Storage Temperature Range -65°C to +150°C
 Lead Temperature Range (Soldering 60 sec) +300°C

NOTES

¹Stresses above those listed under Absolute Maximum Ratings may cause permanent damage to the device. This is a stress rating only; functional operation of the device at these or any other conditions above those indicated in the operational section of this specification is not implied. Exposure to absolute maximum rating conditions for extended periods may affect device reliability.

²Thermal Characteristics: 28-lead SSOP Package: $\theta_{JA} = 115.25^{\circ}\text{C/W}$.

PIN CONFIGURATIONS

SSOP Package

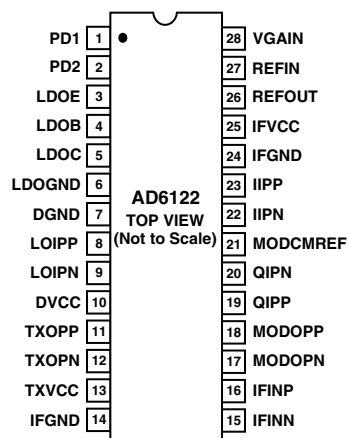

LPCC Package

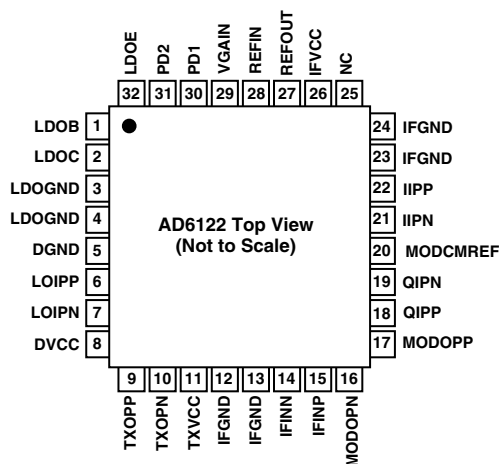

NC = NO CONNECT

ORDERING GUIDE

Model	Temperature Range	Package Description	Package Option
AD6122ARS	-40°C to +85°C	Shrink Small Outline Package (SSOP)	RS-28
AD6122ARSRL	-40°C to +85°C	28-Lead SSOP on Tape-and-Reel	
AD6122ACP	-40°C to +85°C	Chip Scale Package (LPCC)	CP-32
AD6122ACPRL	-40°C to +85°C	32-Leadless LPCC on Tape-and-Reel	

CAUTION

ESD (electrostatic discharge) sensitive device. Electrostatic charges as high as 4000 V readily accumulate on the human body and test equipment and can discharge without detection. Although the AD6122 features proprietary ESD protection circuitry, permanent damage may occur on devices subjected to high-energy electrostatic discharges. Therefore, proper ESD precautions are recommended to avoid performance degradation or loss of functionality.



PIN FUNCTION DESCRIPTIONS

SSOP Pin #	LPCC Pin #	Pin Label	Description	Function
1	30	PD1	Power-Down 1	IF Amplifier Power-Down Control Input; CMOS Compatible; HIGH = Entire IC Powers Down, LOW = IF Amplifiers On.
2	31	PD2	Power-Down 2	Modulator Power-Down Control Input; CMOS Compatible; HIGH = Modulator Off, LOW = Modulator On.
3	32	LDOE	Low Dropout Regulator Pass Transistor Emitter Connection	Connects to Emitter of External PNP Pass Transistor and VCC.
4	1	LDOB	Low Dropout Regulator Pass Transistor Base	Connects to Base of External PNP Pass Transistor.
5	2	LDOC	Low Dropout Regulator Pass Transistor Collector	Connects to Collector of External PNP Pass Transistor.
6	3, 4	LDOGND	Low Dropout Regulator Ground	Ground.
7	5	DGND	Digital Ground	Ground.
8	6	LOIPP	Local Oscillator “Positive” Input	Connects to Local Oscillator; AC Coupled.
9	7	LOIPN	Local Oscillator “Negative” Input	Connects to Ground via Decoupling Capacitor.
10	8	DVCC	Digital VCC	Connects to Digital Supply.
11	9	TXOPP	Transmit Output “Positive”	Connects to Output Filter; AC Coupled.
12	10	TXOPN	Transmit Output “Negative”	Connects to Output Filter; AC Coupled.
13	11	TXVCC	Transmit Output VCC	Connects to LDO Output via Decoupling Network.
14	12, 13	IFGND	IF Ground	Ground.
15	14	IFINN	IF Input “Negative”	IF “Negative” Input from LC Roofing Filter.
16	15	IFINP	IF Input “Positive”	IF “Positive” Input from LC Roofing Filter.
17	16	MODOPN	Modulator “Negative” If Output	Output Modulator Output to LC Roofing Filter.
18	17	MODOPP	Modulator “Positive” Output	Modulator Output to LC Roofing Filter.
19	18	QIPP	Q Input “Positive”	Connects to Q “Positive” Output of Baseband IC.
20	19	QIPN	Q Input “Negative”	Connects to Q “Negative” Output of Baseband IC.
21	20	MODCMREF	Modulator Common-Mode Reference Out	Connects to CDMA Baseband Converter Tx DAC Common-Mode Reference Input.
22	21	IIPN	I Input “Negative”	Connects to I “Negative” Output of Baseband IC.
23	22	IIPP	I Input “Positive”	Connects to I “Positive” Output of Baseband IC.
24	23, 24	IFGND	Ground	Connects to IF Ground.
	25	NC	No Connect	
25	26	IFVCC	IF VCC	Connects to Decoupled Output of LDO Regulator.
26	27	REFOUT	Gain Control Reference Output	Provides 1.23 V Voltage Reference Output for DAC in CDMA Baseband Converter and REFIN.
27	28	REFIN	Gain Control Reference Input	Accepts 1.23 V Reference Input from REFOUT or External Reference.
28	29	VGAIN	Gain Control Voltage Input	Accepts Gain Control Input Voltage from External DAC. Max Gain = 2.5 V; Min Gain = 0.5 V.

Test Figures

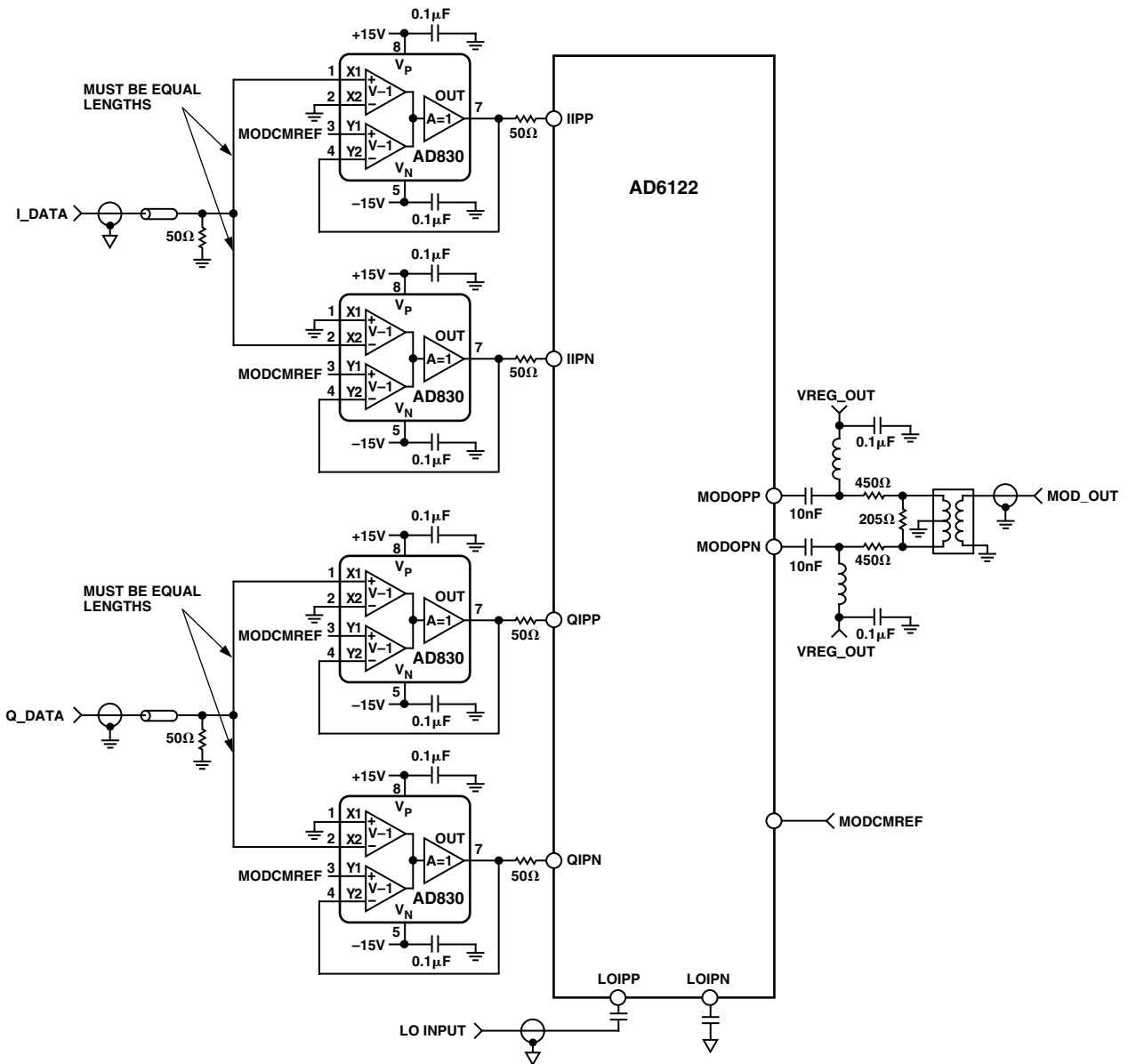

Figure 1. Quadrature Modulator's Characterization Input and Output Impedance Matches

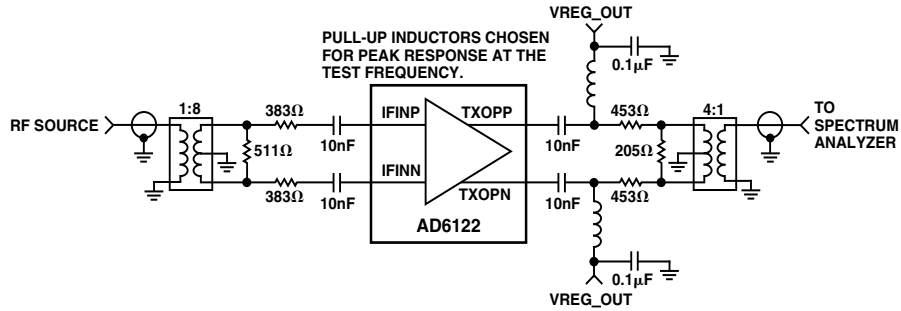

Figure 2. IF Amplifier's Characterization Input and Output Impedance Matches

NOTE: RF CABLES FOR I AND Q PATHS MUST BE OF EQUAL LENGTH

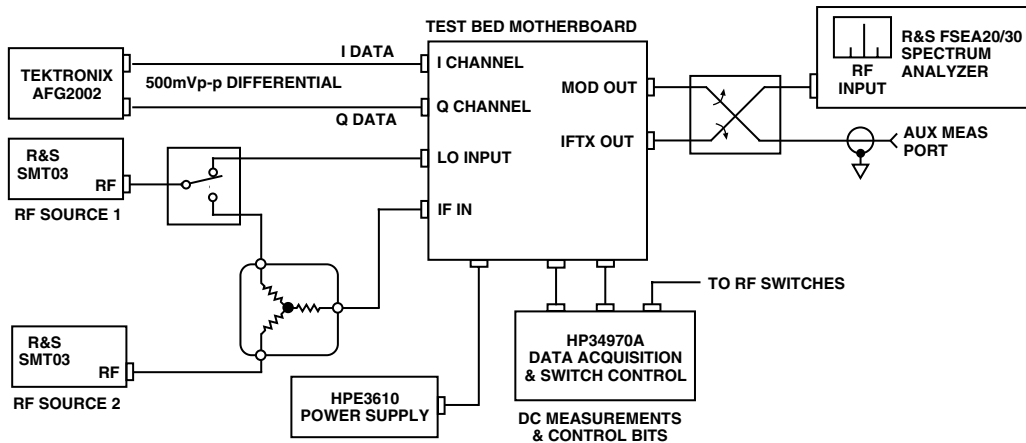

Figure 3. General Test Set

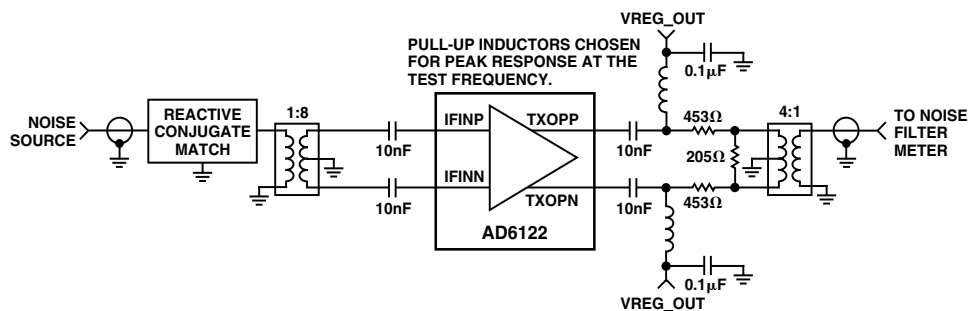
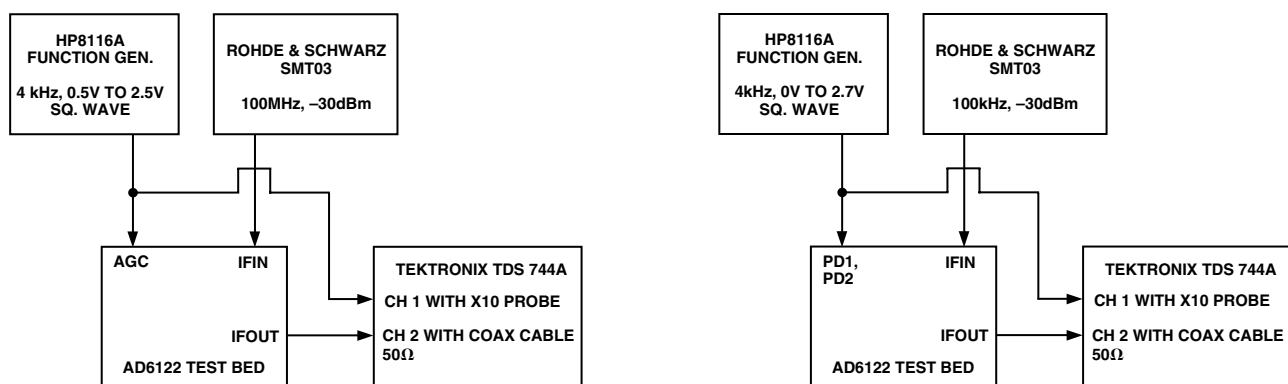

Figure 4. IF Amplifier's Noise Figure Test Set



a. Response Time from Gain Control to IF Output

b. Response Time from PD1 and PD2 Control to IF Output

Figure 5. Response Time Setup

AD6122—Typical Performance Characteristics

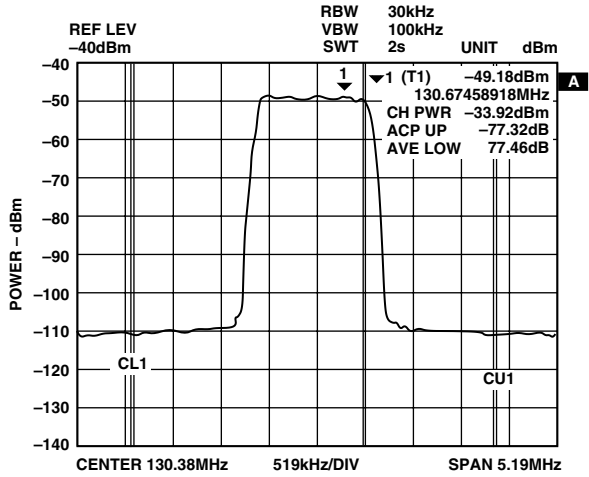

Figure 6. Spectral Plot at Modulator Outputs: ACPR

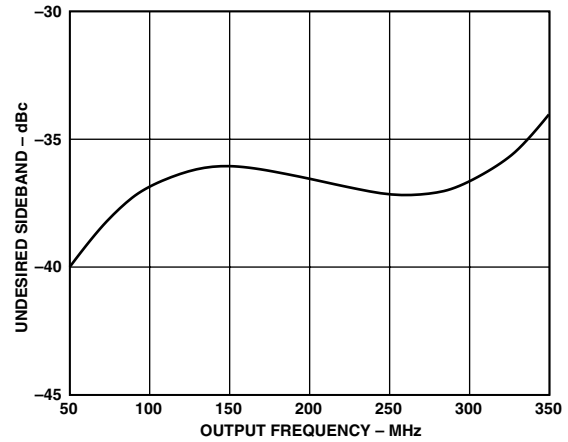

Figure 9. Modulator Output Undesired Sideband vs. Output Frequency

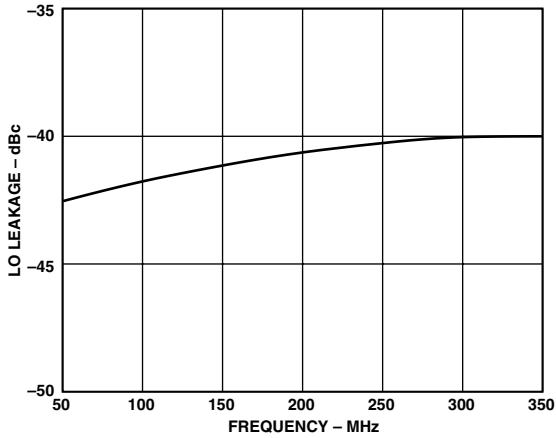

Figure 7. Modulator LO Leakage vs. Output Frequency

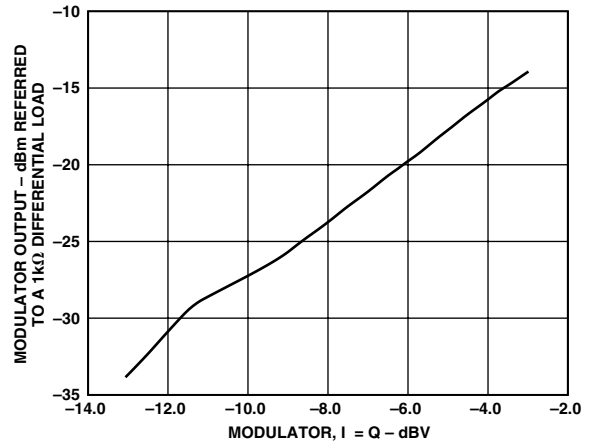

Figure 10. Modulator Gain: Input (dBV) vs. Output (dBm)

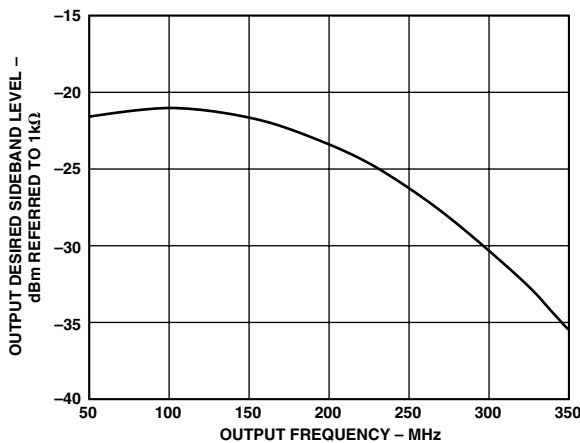

Figure 8. Modulator Output Desired Sideband vs. Output Frequency Without Roofing Filter

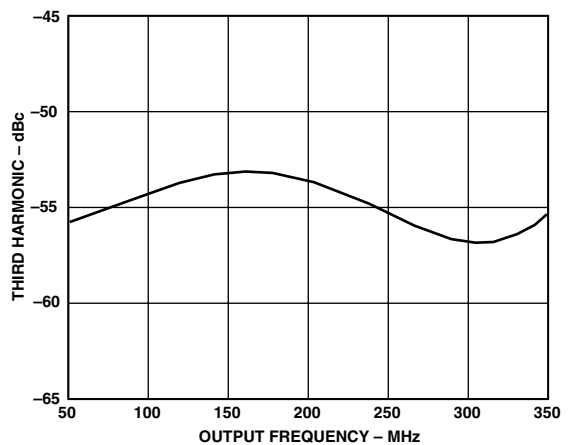

Figure 11. Modulator Third Harmonic

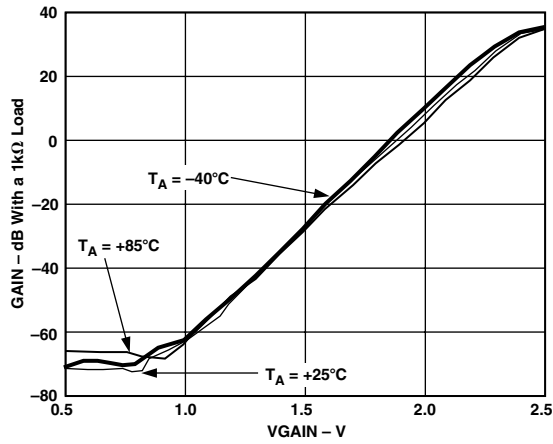

Figure 12. IF Amplifier Response Curve: Gain vs. VGAIN, $T_A = -40^\circ\text{C}, +25^\circ\text{C}, +85^\circ\text{C}$

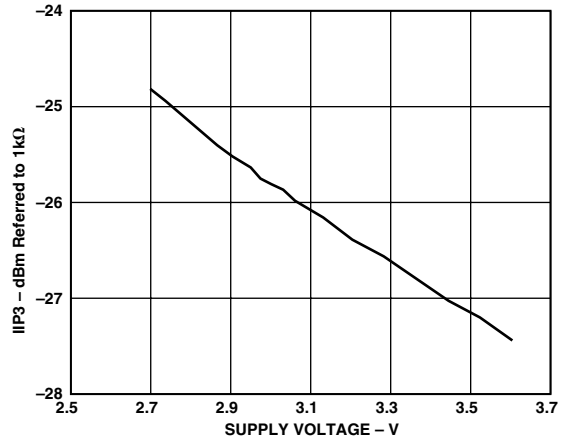

Figure 15. IF Amplifier Input IP3 vs. Supply Voltage

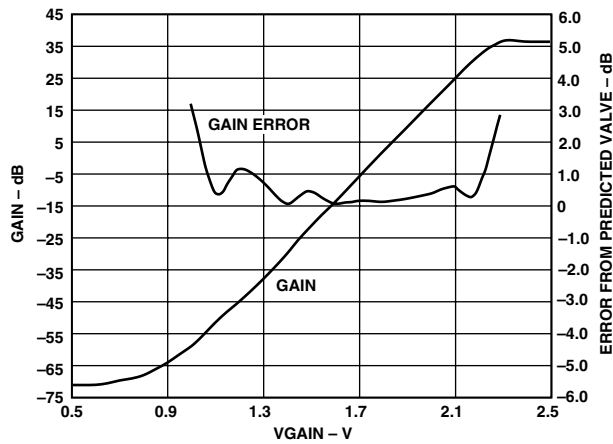

Figure 13. IF Amplifier Gain and Error vs. VGAIN

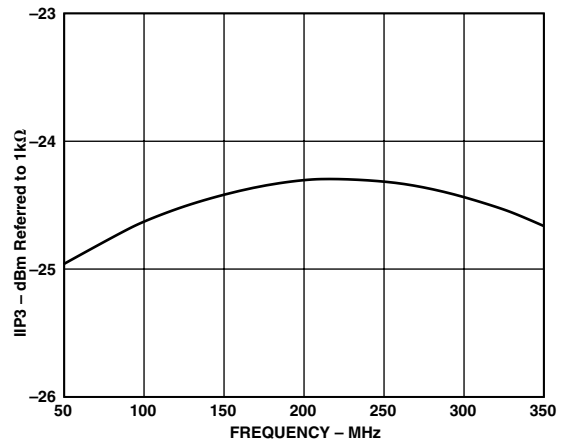

Figure 16. IF Amplifier Input IP3 vs. Frequency

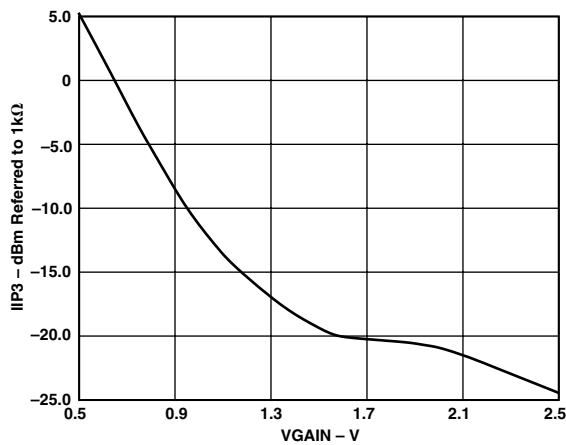

Figure 14. IF Amplifier Input IP3 vs. VGAIN

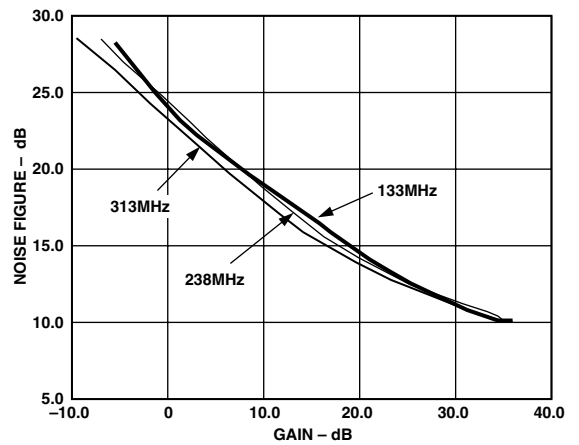

Figure 17. IF Amplifier Noise Figure vs. Gain

AD6122

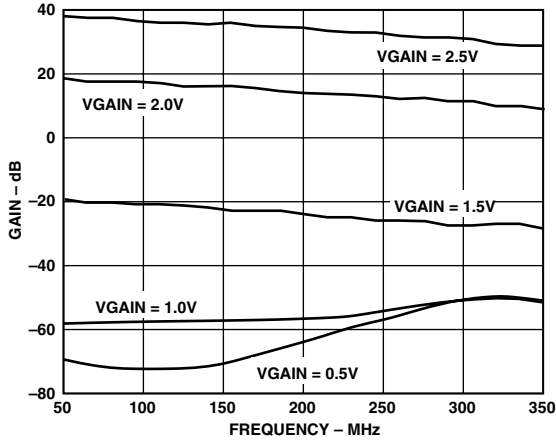

Figure 18. IF Amplifier Gain vs. Frequency for VGAIN = 2.5 V, 2.0 V, 1.5 V, 1.0 V

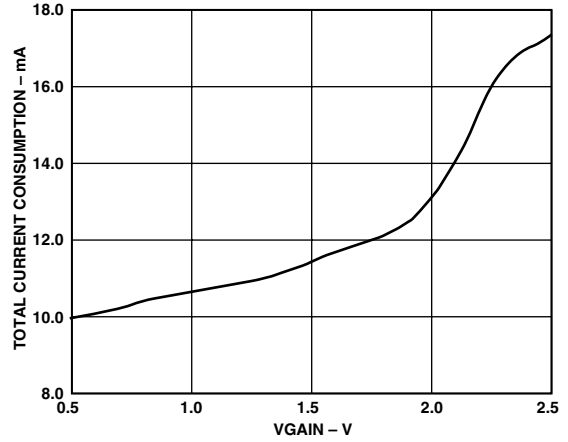

Figure 19. Total Current Consumption vs. VGAIN

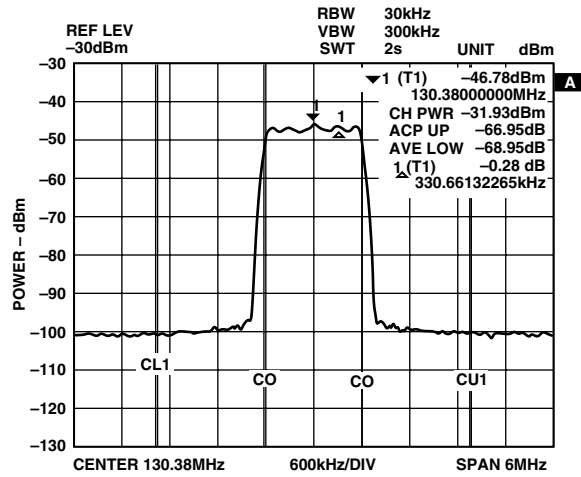

Figure 20. ACPR of Cascaded Modulator, 20 dB Pad and IF Amplifier: Spectral Plot

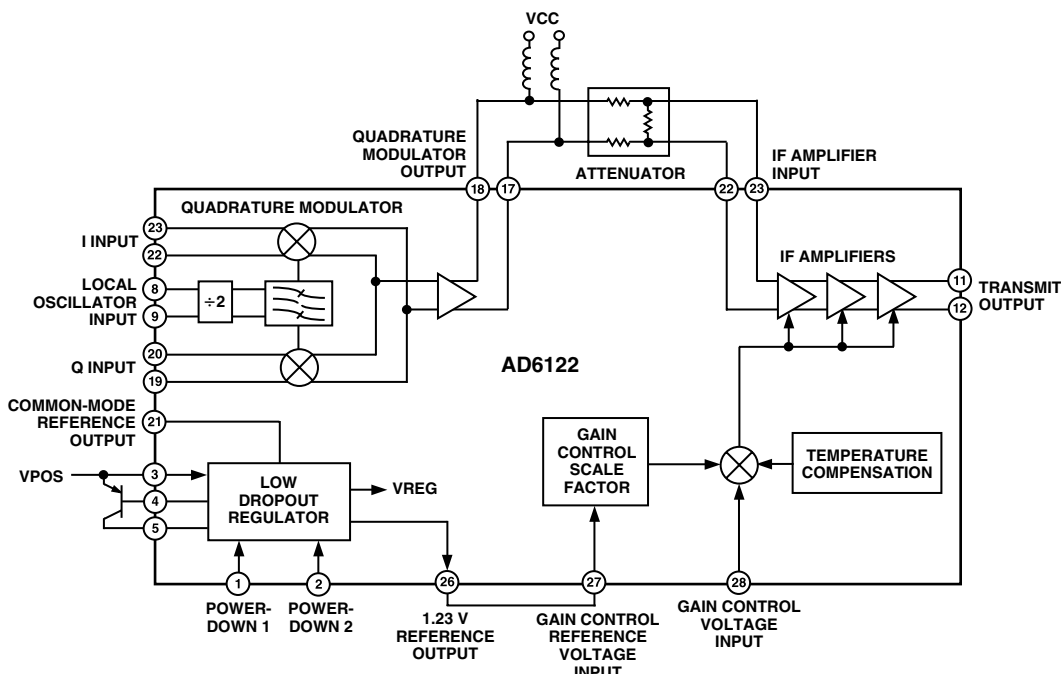

Figure 21. Block Diagram

THEORY OF OPERATION

The CDMA Transmitter IF Subsystem (Figure 21) consists of an I and Q modulator with a divide-by-two quadrature generator, high dynamic range IF amplifiers with voltage-controlled gain, a low dropout regulator and power-down control inputs.

I and Q Modulator

The I and Q modulator accepts differential quadrature baseband inputs from CDMA baseband converters. The LO is injected at twice the IF frequency. A divide-by-two quadrature generator followed by dual polyphase filters ensures $\pm 1^\circ$ quadrature accuracy (Figure 22).

For 500 mV p-p differential I and Q input signals, the output power of the modulator will be -21 dBm referred to $1\text{ k}\Omega$ when the output of the modulator is loaded with a $1\text{ k}\Omega$ differential load. With the maximum input conditions stated above, the modulator outputs are a $225\text{ }\mu\text{A}$ p-p differential current; consequently, the output load will greatly affect the output power of the modulator.

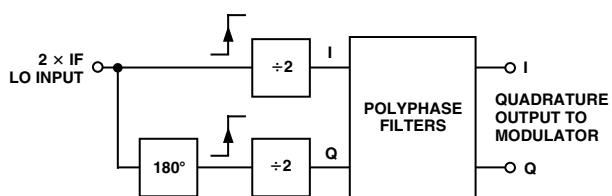

Figure 22. Simplified Quadrature Generator Circuit

The I and Q modulator also provides a common mode reference signal at the MODCMREF pin. This voltage is a dc voltage set to 1.408 V when a 2.7 V supply is used. It is used to dc bias the output of the DAC that provides I and Q inputs to the modulator.

IF Amplifiers and Gain Control

The IF amplifiers provide an 86 dB linear in dB gain control range. The input stage uses a differential, continuously variable attenuator based on Analog Devices' patented X-AMP™ topology. This low noise attenuator consists of a differential R-2R ladder network, linear interpolator and a fixed gain amplifier. The IF amplifier's input impedance is $1\text{ k}\Omega$ differential. Similar to the I and Q modulator's output, the IF amplifier's output is a differential current, which will vary depending upon the gain control voltage. In order to achieve the specified gain, the output of the IF amplifiers should be loaded with a $1\text{ k}\Omega$ differential load.

The gain control circuits contain both temperature compensation circuitry and a choice of internal or external reference for adjusting the gain scale factor. The gain control input accepts an external gain control voltage input from a DAC. It provides 97 dB of gain control range with a nominal 75 dB/V scale factor.

The external gain control input signal should be a clean signal. It is recommended to filter this signal in order to eliminate the noise that results from the DAC. If a noisy signal is used for the gain control voltage, VGAIN inband and adjacent channel noise peaking can occur at the output of the AD6122. A simple RC filter can be employed, but care should be taken with its design. If too big a resistor is used, a large voltage drop may occur across the resistor, resulting in lower gain than expected (as a result of a lower voltage reaching the AD6122). An RC filter with a 20 kHz bandwidth, employing a $1\text{ k}\Omega$ resistor is appropriate. This results in an 8.2 nF capacitor. The resulting circuit is shown in Figure 23. Note that the input resistance at the VGAIN pin is approximately $100\text{ k}\Omega$.

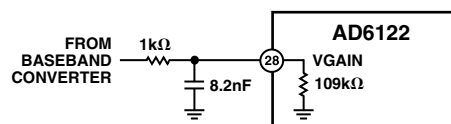

Figure 23. Gain Voltage Filtering

AD6122

The AD6122's overall gain, expressed in decibels, is linear in dB with respect to the automatic gain control (AGC) voltage, VGAIN. Either REFOUT or an external reference voltage connected to REFIN may be used to set the voltage range for VGAIN. When the internal 1.23 V reference, REFOUT, is connected to REFIN, VGAIN will control the entire AGC range when it is typically set between 0.5 V and 2.5 V. Minimum gain occurs at minimum voltage on VGAIN and maximum gain occurs at maximum voltage on VGAIN. The maximum and minimum gain will not change with a change in voltage at REFIN. Rather, the slope of the gain curve will change as a result of a change in the required range for VGAIN. Figure 24 shows the piecewise linear approximation of the gain curve for the AD6122.

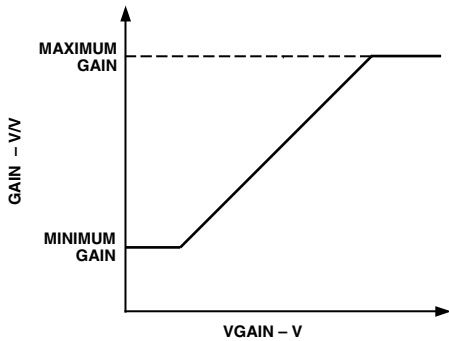

Figure 24. Piecewise Linear Approximation for the AD6122 Gain Curve

Because the minimum and maximum gain from the AD6122 are constant, we can approximate the VGAIN range for a given REFIN voltage by using Equation 1.

$$VGAIN = \frac{(GAIN - MinGain) \times 1.6REFIN}{MaxGain - MinGain} + 0.4 REFIN \quad (1)$$

Where *MaxGain* is the maximum gain (+34 dB) in dB, *MinGain* is the minimum gain (-63 dB) in dB, *REFIN* is the reference input voltage, in volts, *VGAIN* is the gain control voltage input, in volts, and *GAIN* is the particular gain, in dB, we would have for a given REFIN and VGAIN. Consequently, for any REFIN we choose, we can calculate the VGAIN range by solving Equation 1 for VGAIN. For example, in order to determine the VGAIN value for the maximum gain condition, given a 1.23 V REFIN, we can solve Equation 1 for VGAIN by substituting +34 dB for GAIN and MaxGain, -63 dB for MinGain and 1.23 V for REFIN. VGAIN can then be calculated to be 2.46 V, or approximately 2.5 V. For the minimum gain condition, we can determine the VGAIN value by substituting 34 dB for MaxGain, -63 dB for GAIN and MinGain and 1.23 V for REFIN. VGAIN can then be calculated to be 0.492 V or approximately 0.5 V.

Power-Down Control

The AD6122 can be operated with the IF amplifiers and quadrature modulator both powered up, both powered down or with the IF amplifiers powered up and the modulator powered down. The AD6122 cannot operate with only the modulator powered

up. The control is provided via two control pins, PD1 and PD2. Table I shows the operating modes of the AD6122.

Table I. Operating Modes

PD1	PD2	IF Amp	Modulator
0	0	ON	ON
0	1	ON	OFF
1	0	INVALID STATE	INVALID STATE
1	1	OFF	OFF

Low Dropout Regulator

The AD6122 incorporates an integrated low dropout regulator. The regulator accepts inputs from 2.9 V to 4.2 V and supplies a constant 2.7 V reference output at LDOC. The 2.7 V signal can be used to provide the dc voltages required for the DVCC, TXVCC and IFVCC dc supplies. In order to configure the low dropout regulator, an external pass transistor is required. A pnp bipolar junction transistor with a minimum h_{FE} of 100 and a maximum h_{FE} of 300 and a $V_{CE_{SAT}}$ of -0.4 V is required. In order to use the low dropout regulator, configure the transistor as shown in Figure 25. The 18 pF capacitor in Figure 25 is used for decoupling the 2.7 V dc signal.

In addition to the low dropout regulator, a band-gap voltage reference produces a 1.23 V reference voltage at REFOUT. This reference voltage will be present whenever a 2.7 V dc signal is present on pin LDOC. This 1.23 V reference voltage can then be used to provide the gain reference signal required for REFIN and the reference voltage for the transmit DACs in a baseband converter.

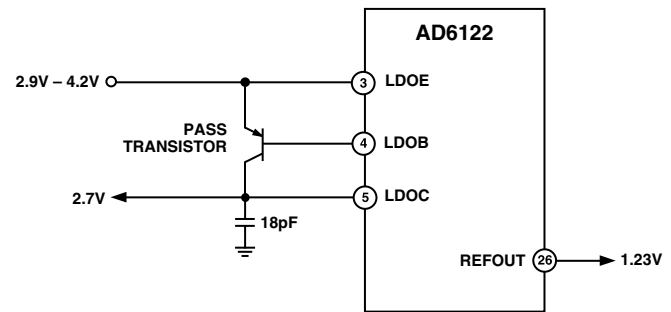

Figure 25. Configuring the Low Dropout Regulator

It is possible to bypass the low dropout regulator on the AD6122 and use an external regulator instead. In order to bypass the integrated low dropout regulator, connect pins LDOE, LDOB and LDOC together and then connect them all to the 2.7 V external regulator voltage. This configuration is shown in Figure 26. Even when the low dropout regulator is bypassed, the 1.23 V reference voltage at pin REFOUT is still present.

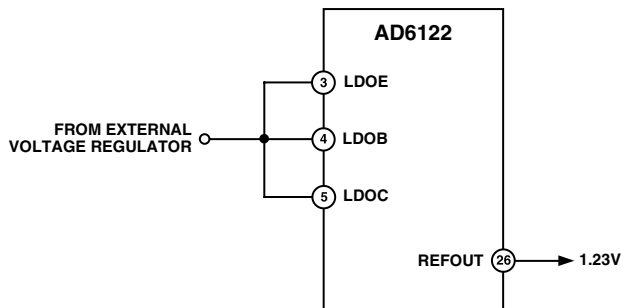

Figure 26. Configuration for Bypassing the Low Dropout Regulator

ROOFING FILTER

Because the outputs of the AD6122 modulator are open collector, the parasitic capacitances seen at the output of the modulator, and inputs of the IF amplifiers, are high enough to create a low-pass filter, which may attenuate the IF signal. Consequently, the parasitic capacitance must be cancelled by using external inductors to form a parallel resonant circuit. The external inductors and the internal parasitic capacitors form what is known as the roofing filter, with the resonant frequency given by Equation 2.

$$f_0 = \frac{1}{2\pi\sqrt{LC_{PAR}}} \quad (2)$$

where f_0 is the IF frequency, in Hertz, C_{PAR} is the total parasitic capacitance in Farads, and L is the value of external inductors, in henrys.

The roofing filter may be composed of the pull-up inductors required on the open collector outputs of the I and Q modulator. This configuration is shown in Figure 27. The 10 nF capacitors are used for ac coupling.

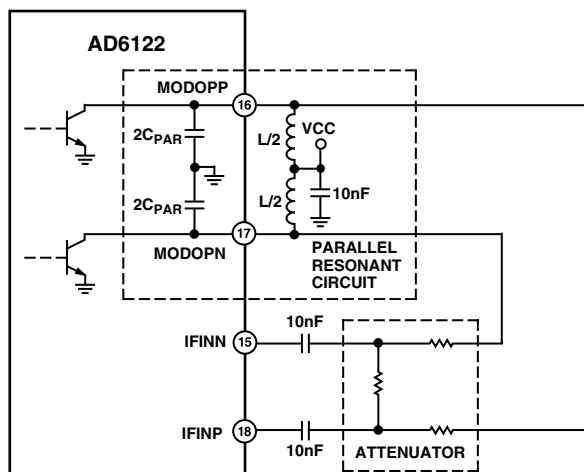

Figure 27. Roofing Filter Configuration

The attenuator is discussed in the next section entitled Measuring Adjacent Channel Protection Ratio (ACPR).

In order to confirm whether the roofing filter has been correctly designed, sweep the LO frequency and view the output of the IF amplifier on a spectrum analyzer. The signal should peak at the IF frequency if the inductor value is correct. The Q of the filter should be low enough so that variations in the parasitic capacitances should be negligible.

The value of inductor required will be a function of the IF frequency at which we are operating. The values of inductors used during characterization at Analog Devices are shown in Table II. Because the exact value will also be a function of printed circuit board layout, we will have to vary the value from those in Table II to those required for our board.

Table II. Roofing Filter Inductor Values

IF Frequency (MHz)	Value of Roofing Filter Inductor (nH)
50–125	470
126–200	150
201–275	68
276–350	27

It should be noted that the roofing filter is only required when cascading the output from the I/Q modulator to the input of the IF amplifiers. If we are driving into the IF amplifiers directly, no roofing filter is required, however, pull-up inductors are required in order to set the dc voltage of the open collector modulator outputs.

MEASURING ADJACENT CHANNEL POWER RATIO (ACPR)

At maximum IF gain and specified input conditions (500 mV p-p baseband inputs), the output of the I/Q modulator is 11 dB greater than the P1 dB (one dB compression point) of the IF amplifiers. This configuration maximizes the ratio of signal to LO feedthrough and also maximizes the signal to noise ratio. Once these ratios are maximized, we can attenuate the noise, signal and LO feedthrough without affecting the ratios. Therefore, attenuation is required between the I/Q modulator and the IF amplifiers.

In order to determine exactly how much attenuation is required, we must recognize that ACPR is a function of the attenuation from the modulator outputs to the IF amplifier inputs. As a result, in order to determine how much attenuation is required, we must first know how good an ACPR performance is desired. If too much attenuation is applied, the ACPR will be very good, but, the IF amplifier's output power level will be low, possibly resulting in poor signal to noise ratio and possibly requiring additional amplification external to the AD6122.

An appropriate method that can be used to provide the correct amount of attenuation between the modulator outputs and the IF amplifier inputs is a simple differential voltage divider. The topology and its design equations are shown in Figure 28 and Equations 3 and 4. The input impedance of the IF amplifiers is typically 1 k Ω . As a result, if we design resistor R2 to be much less than 1 k Ω , we can neglect the effects of the IF amplifier's input impedance on the attenuator.

AD6122

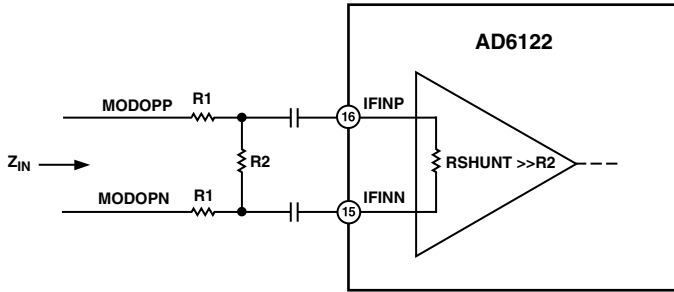

Figure 28. Pad Topology

$$L = 20 \log \left(\frac{\frac{1}{R1}}{\frac{1}{R1} + \frac{1}{R2/2}} \right) \quad (3)$$

$$Z_{IN} = 2R1 + R2 \quad (4)$$

where L is the transducer loss (or loss through the pad) in dB and Z_{IN} is the desired input resistance in ohms. Using these equations, we can design the attenuator circuit to provide whatever amount of attenuation we require.

This circuit is very sensitive to parasitic capacitances. As a result, extra care should be taken to ensure minimum and equal printed circuit board transmission lines. We should also try to keep $R2$ small in order to minimize the effects of printed circuit board parasitic capacitance on loading the output of the pad.

In conclusion, we have to develop a system-level ACPR budget for our radio, and from that budget determine how much ACPR performance we desire from the AD6122. We then need to implement the appropriate attenuation network to get that ACPR performance.

LEVEL DIAGRAM

Figure 29 is provided to better understand the different voltage levels you can expect to see at different points of the AD6122. It represents the voltage and power levels expected for a maximum input condition of 500 mV p-p at the I and Q modulator and maximum gain in the IF amplifiers. When trying to make these measurements, a high impedance (10 MΩ) active FET probe (for example, the Tek P6204, from Tektronix) should be used to minimize the effects of loading the circuit with the probe.

In order to produce these results, the attenuator is designed to have a 1 kΩ input impedance and the output of the IF amplifiers are loaded with 1 kΩ. The roofing filter is designed to resonate the parasitic capacitance at the IF frequency.

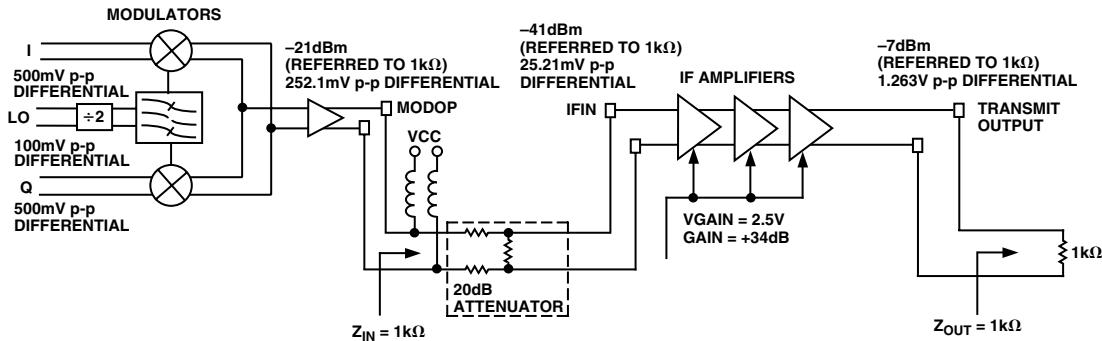

Figure 29. Level Diagram

INPUT INTERFACES

The AD6122 interfaces to CDMA baseband converters providing either IF or baseband outputs. The baseband input is provided by direct connection of the baseband converter's baseband output to the baseband input of the AD6122 (Figure 30). The IF amplifier's gain control is provided by connection of the transmit AGC DAC's output on the baseband converter, through a low-pass filter to the VGAIN pin on the AD6122.

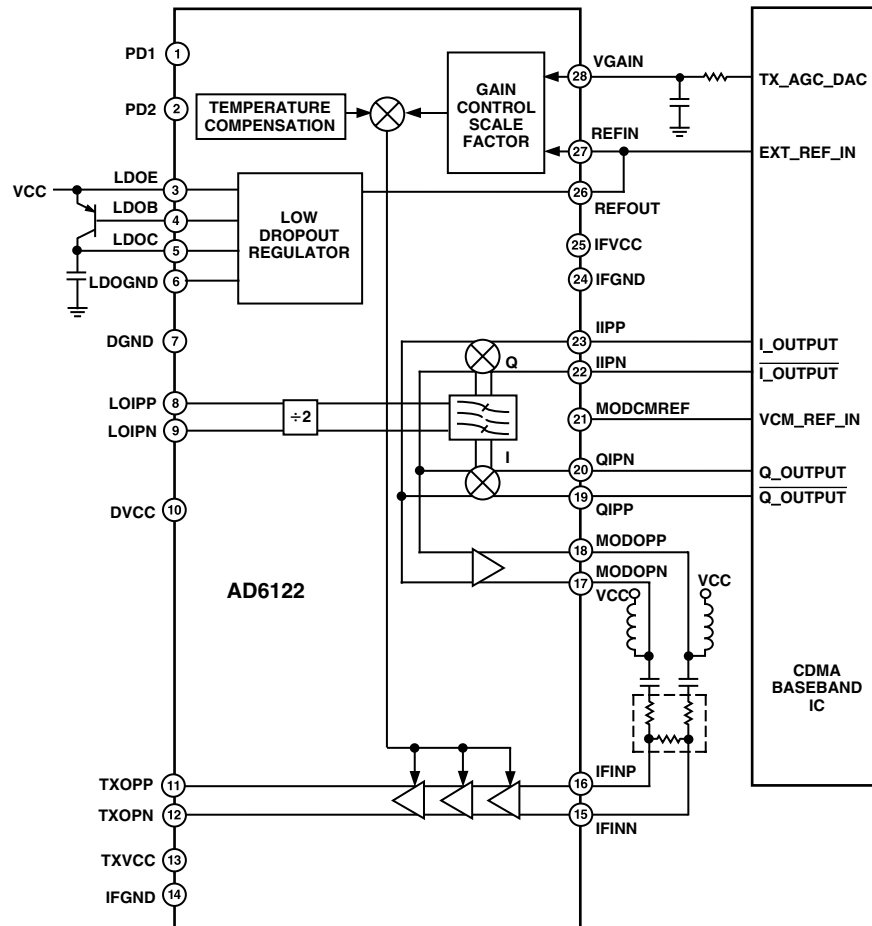

Figure 30. Typical Connections to Baseband IC Using I and Q Inputs with SSOP Package

AD6122

AD6122 Evaluation Board

The AD6122 Evaluation Board consists of an AD6122, I/O connectors, a 20-pin dual header, 2-pin headers and four AD830 high speed video difference amplifiers. It allows the user to evaluate the AD6122's IF amplifier and modulator together or separately. Because the AD6122 may be used at any IF from 50 MHz to 350 MHz, pads are provided on the LOIPP input, TXOP output, MODOP output and IFIP inputs to allow the user to add matching networks. The board is configured for an IF frequency of 130.38 MHz when shipped. There is no difference between the configuration of the boards with the SSOP or LPCC package.

The AD830s are used to provide single-ended to differential conversion and the appropriate phase shift for the I and Q data input pins. As a result, a single-ended signal generator can be used to generate these signals.

In order to test the power-down modes of the AD6122, locate the two pin headers on the AD6122 evaluation boards labeled PD1 and PD2. By open-circuiting the pins labeled PD1, the IF amplifiers power down. By open-circuiting the pins labeled PD2, the modulator powers down. Note that the IF amplifiers and modulator are powered down unless the pins on the two pin headers, PD1 and PD2, are short circuited.

The IF input port impedance match used during characterization of the AD6122 at Analog Devices is as follows:

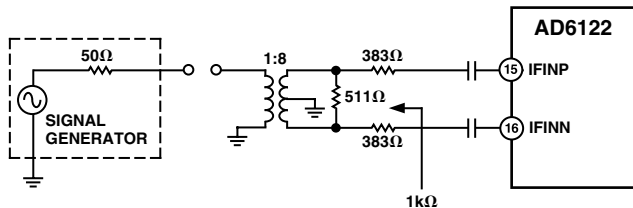

Figure 31. IF Input Port Impedance Match Used During Characterization at ADI

This is a broadband lossy match used for characterization over the 50 MHz to 350 MHz frequency range. All dBm references in the characterization data collected using this match are referenced to 1 k Ω . Note that the 1:8 ratio in Figure 31 is an impedance ratio and not a voltage ratio.

The IF output port impedance match used during characterization at Analog Devices is as follows:

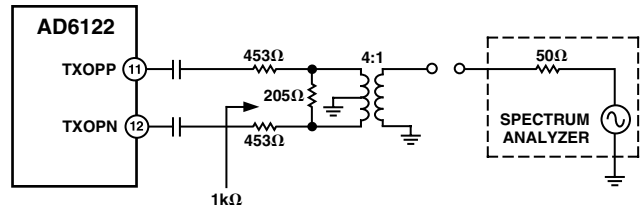

Figure 32. IF Output Port Impedance Match Used During Characterization at ADI

This is a broadband lossy output match for the 50 MHz to 350 MHz frequency range. The 4:1 ratio in Figure 32 is an impedance ratio and not a voltage ratio.

As shipped, the board is configured as follows:

1. J1 is open and J2 is shorted. This enables the LDO regulator. The external PNP transistor should remain in place even when the regulator is bypassed (the Pin LDOB is pulled up by the transistor).
2. X11, X25, X18 and X26 are shorted and X12, X14, X19 and X21 are opened in order to connect the output of the modulator to the input of the IF amplifiers.
3. L4 and L5, the roofing filter components are optimized for an IF frequency of 130.38 MHz.
4. R14, R15 and R16 set the attenuation between the modulator outputs and the IF amplifier inputs to 20 dB.
5. PD1 and PD2 are pulled low by the jumpers on the two pin headers. To power down the chip, set PD1 and PD2 high by removing the jumpers.

In order to look at the modulator and IF amplifiers separately, disconnect the output of the modulator from the input of the IF amplifiers. This is accomplished by short circuiting X12, X14, X19 and X20 and open circuiting X11, X18, X25 and X26.

Table III describes the high frequency signal connectors on the AD6122 customer sample boards.

Table III. Evaluation Board SMA Signal Connector Description

Connector	Description
I CH	I Modulator Input. 250 mV p-p into 50 Ω termination, dc coupled. The level shifting and phase splitting is done on board by the AD830 amplifiers.
Q CH	Q Modulator Input. 250 mV p-p into 50 Ω termination, ac coupled. The level shifting and phase splitting is done on board by the AD830 amplifiers.
MODOP	Modulator Output. The differential-to-single ended conversion is performed by a balun on the board. Impedance matched to 50 Ω for 130.38 MHz IF frequency.
IFIP	IF Amplifier Input. Single-ended-to-differential conversion performed by a balun on board. Impedance matched to 50 Ω for 130.38 MHz IF frequency.
TXOP	IF Amplifier Output. Differential-to-single-ended conversion performed by a balun on board. Impedance matched to 50 Ω for 130.38 MHz IF frequency.
LOIPP	Local oscillator positive input at $2 \times$ IF frequency.

Table IV lists the connections for the 20-pin power-supply connector.

Table IV. 20-Pin Power Supply Connection Information

Pin #	Function
1	VPOS for AD6122; 2.9 V to 4.2 V using regulator; 2.7 V to 4.2 V bypassing regulator.
2	VPOS for AD6122; 2.9 V to 4.2 V using regulator; 2.7 V to 3.6 V bypassing regulator.
3	Ground.
4	Ground.
5	Ground.
6	Regulated Output or Input Voltage; Connects to Pin 5 on AD6122.
7	Ground.
8	Ground.
9	Ground.
10	Ground.
11	Ground.
12	PD1; Power-Down 1 Input.
13	Ground.
14	1.23 V Reference Voltage from AD6122.
15	Ground.
16	VGAIN; Gain Control Voltage Input.
17	-15 V Supply for AD830 Differential Amplifier.
18	+15 V Supply for AD830 Differential Amplifier.
19	MODCMREF; common-mode reference output for baseband converter common-mode reference input.
20	PD2; Power-Down 2 Input.

A schematic diagram of the evaluation board is on the next two pages.

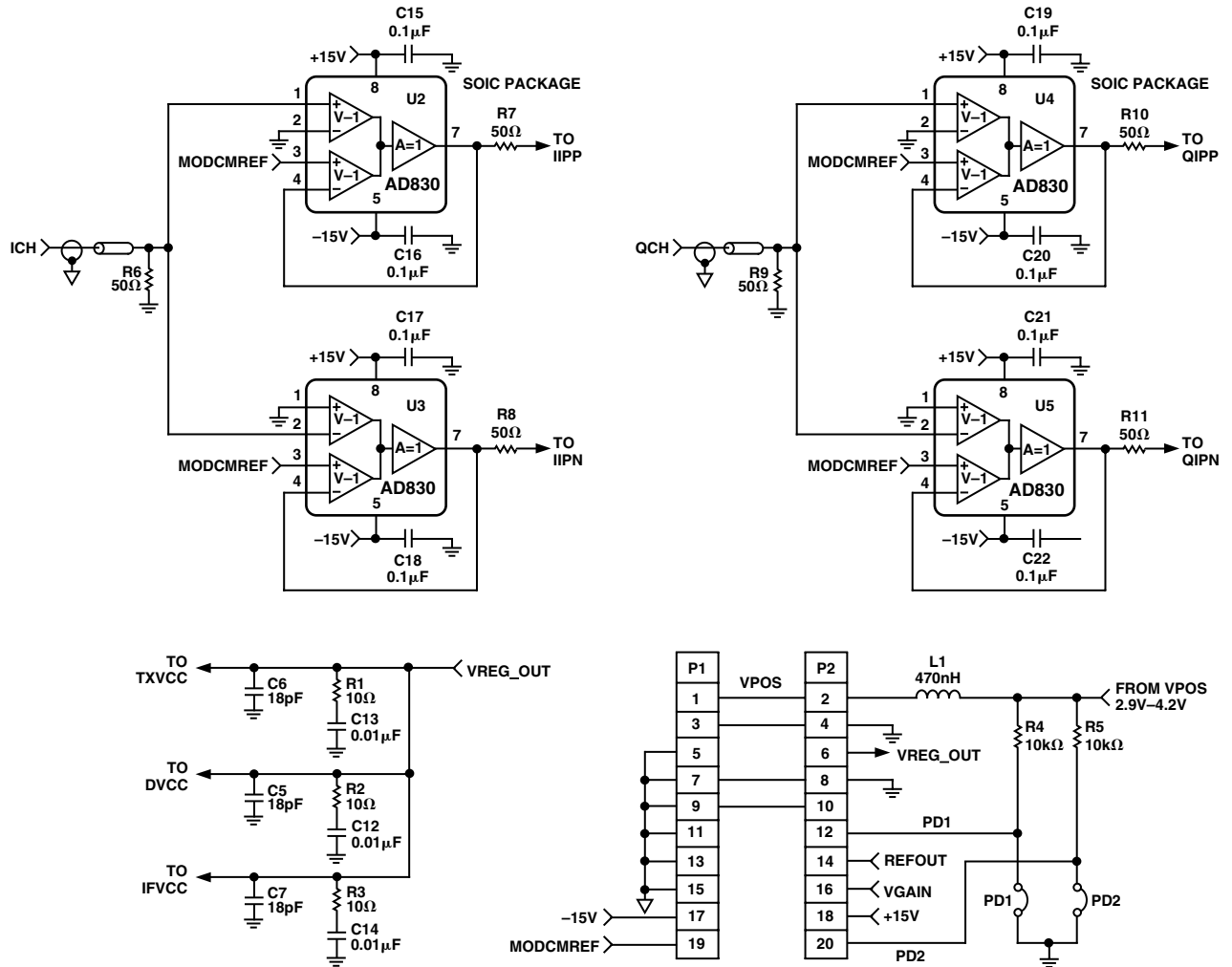

- NOTES:**
1. TO USE THE LDO REGULATOR, SHORT J2 AND OPEN J1.
 2. TO BYPASS THE REGULATOR, SHORT J1 AND OPEN J2
 3. TO CONNECT THE OUTPUT OF THE MODULATOR TO THE INPUT OF THE IF AMP, SHORT J5 AND J6.
TO TEST THE MODULATOR AND THE IF AMP SEPARATELY, OPEN J5 AND J6.
 4.  INDICATES A 50Ω TRACE.

Figure 34. Schematic Diagram of the Evaluation Board

OUTLINE DIMENSIONS

Dimensions shown in inches and (mm).

28-Lead SSOP
(RS-28)

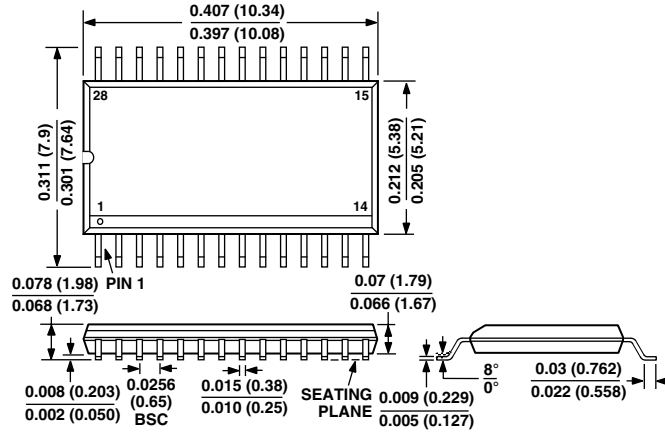

32-Leadless Chip Scale Package (LPCC)
(CP-32)

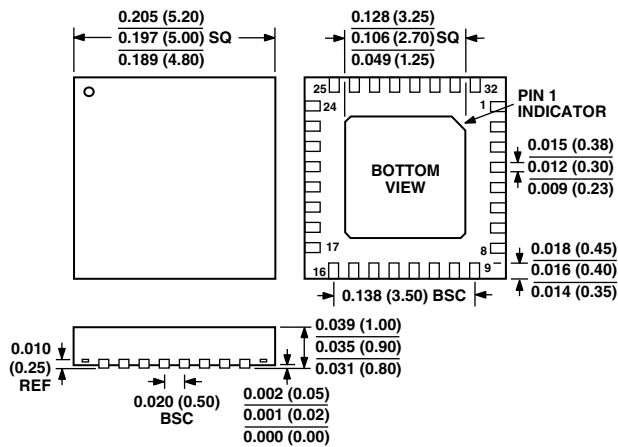

CONTROLLING DIMENSIONS ARE IN MILLIMETERS
DIMENSIONS MEET JEDEC MO-220-VHHD-2



LittleDiode supplies new, hard to find or obsolete electronic components and semiconductors all over the world.

With over two million different components listed you are sure to find the part you need.

Feel free to visit us today at our online store:

LittleDiode.com

Looking forward to providing you with the best possible service.