

### FEATURES

- 65 MSPS Minimum Sample Rate
- 80 dB Spurious-Free Dynamic Range
- IF-Sampling to 70 MHz
- 710 mW Power Dissipation
- Single +5 V Supply
- On-Chip T/H and Reference
- Twos Complement Output Format
- 3.3 V or 5 V CMOS-Compatible Output Levels

### APPLICATIONS

- Cellular/PCS Base Stations
- Multichannel, Multimode Receivers
- GPS Anti-Jamming Receivers
- Communications Receivers
- Phased Array Receivers

### PRODUCT DESCRIPTION

The AD6640 is a high speed, high performance, low power, monolithic 12-bit analog-to-digital converter. All necessary functions, including track-and-hold (T/H) and reference are included on-chip to provide a complete conversion solution. The AD6640 runs on a single +5 V supply and provides CMOS-compatible digital outputs at 65 MSPS.

Specifically designed to address the needs of multichannel, multimode receivers, the AD6640 maintains 80 dB spurious-free dynamic range (SFDR) over a bandwidth of 25 MHz. Noise performance is also exceptional; typical signal-to-noise ratio is 68 dB.

The AD6640 is built on Analog Devices' high speed complementary bipolar process (XFCB) and uses an innovative multipass architecture. Units are packaged in a 44-terminal Plastic Thin Quad Flatpack (TQFP) specified from -40°C to +85°C.

### FUNCTIONAL BLOCK DIAGRAM

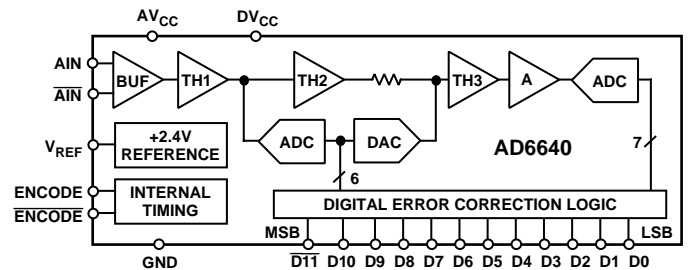

### PRODUCT HIGHLIGHTS

1. Guaranteed sample rate is 65 MSPS.
2. Fully differential analog input stage specified for frequencies up to 70 MHz; enables "IF Sampling."
3. Low power dissipation: 710 mW off a single +5 V supply.
4. Digital outputs may be run on +3.3 V supply for easy interface to digital ASICs.
5. Complete Solution: reference and track-and-hold.
6. Packaged in small, surface mount, plastic 44-terminal TQFP.

REV. 0

Information furnished by Analog Devices is believed to be accurate and reliable. However, no responsibility is assumed by Analog Devices for its use, nor for any infringements of patents or other rights of third parties which may result from its use. No license is granted by implication or otherwise under any patent or patent rights of Analog Devices.

# AD6640—SPECIFICATIONS

## DC SPECIFICATIONS ( $AV_{CC} = +5\text{ V}$ , $DV_{CC} = +3.3\text{ V}$ ; $T_{MIN} = -40^{\circ}\text{C}$ , $T_{MAX} = +85^{\circ}\text{C}$ )

Parameter	Temp	Test Level	Min	AD6640AST Typ	Max	Units
RESOLUTION				12		Bits
ACCURACY				GUARANTEED		
No Missing Codes	+25°C	I				
Offset Error	Full	VI	-10	3.5	+10	mV
Gain Error	Full	VI	-10	4.0	+10	% FS
Differential Nonlinearity (DNL) <sup>1</sup>	+25°C	I	-1.0	±0.5	+1.5	LSB
Integral Nonlinearity (INL) <sup>1</sup>	Full	V		±1.25		LSB
TEMPERATURE DRIFT						
Offset Error	Full	V		50		ppm/°C
Gain Error	Full	V		100		ppm/°C
POWER SUPPLY REJECTION (PSRR)	Full	V		±0.5		mV/V
REFERENCE OUT ( $V_{REF}$ ) <sup>2</sup>	Full	V		2.4		V
ANALOG INPUTS ( $A_{IN}$ , $\overline{A_{IN}}$ ) <sup>3</sup>						
Analog Input Common-Mode Range <sup>4</sup>	Full	V		$V_{REF} \pm 0.05$		V
Differential Input Voltage Range	Full	V		2.0		V p-p
Differential Input Resistance	Full	IV	0.7	0.9	1.1	kΩ
Differential Input Capacitance	+25°C	V		1.5		pF
POWER SUPPLY						
Supply Voltage						
$AV_{CC}$	Full	VI	4.75	5.0	5.25	V
$DV_{CC}$	Full	VI	3.0	3.3	5.25	V
Supply Current						
$IA_{VCC}$ ( $AV_{CC} = 5.0\text{ V}$ )	Full	VI		135	160	mA
$ID_{VCC}$ ( $DV_{CC} = 3.3\text{ V}$ )	Full	VI		10	20	mA
POWER CONSUMPTION	Full	VI		710	865	mW

### NOTES

<sup>1</sup>ENCODE = 20 MSPS

<sup>2</sup>If  $V_{REF}$  is used to provide a dc offset to other circuits, it should first be buffered.

<sup>3</sup>The AD6640 is designed to be driven differentially. Both  $A_{IN}$  and  $\overline{A_{IN}}$  should be driven at levels  $V_{REF} \pm 0.5$  volts. The input signals should be 180 degrees out of phase to produce a 2 V p-p differential input signal. See Driving the Analog Inputs section for more details.

<sup>4</sup>Analog input common-mode range specifies the offset range the analog inputs can tolerate in dc-coupled applications (see Figure 35 for more detail).

Specifications subject to change without notice.

## DIGITAL SPECIFICATIONS ( $AV_{CC} = +5\text{ V}$ , $DV_{CC} = +3.3\text{ V}$ ; $T_{MIN} = -40^{\circ}\text{C}$ , $T_{MAX} = +85^{\circ}\text{C}$ )

Parameter	Temp	Test Level	Min	AD6640AST Typ	Max	Units
LOGIC INPUTS ( $\overline{ENC}$ , $\overline{ENC}$ ) <sup>1</sup>						
Encode Input Common-Mode Range <sup>2</sup>	Full	IV	0.2		2.2	V
Differential Input Voltage	Full	IV	0.4			V p-p
Single-Ended Encode					10	V p-p
Logic Compatibility <sup>3</sup>				TTL/CMOS		
Logic "1" Voltage	Full	VI	2.0		5.0	V
Logic "0" Voltage	Full	VI	0		0.8	V
Logic "1" Current ( $V_{INH} = 5\text{ V}$ )	Full	VI	500	650	800	μA
Logic "0" Current ( $V_{INL} = 0\text{ V}$ )	Full	VI	-400	-320	-200	μA
Input Capacitance	+25°C	V		2.5		pF
LOGIC OUTPUTS ( $\overline{D_{II}}$ - $D_0$ ) <sup>4</sup>						
Logic Compatibility				CMOS		
Logic "1" Voltage ( $DV_{CC} = +3.3\text{ V}$ )	Full	VI	2.8	$DV_{CC} - 0.2$		V
Logic "0" Voltage ( $DV_{CC} = +3.3\text{ V}$ )	Full	VI		0.2	0.5	V
Logic "1" Voltage ( $DV_{CC} = +5.0\text{ V}$ )	Full	IV	4.5	$DV_{CC} - 0.3$		V
Logic "0" Voltage ( $DV_{CC} = +5.0\text{ V}$ )	Full	IV		0.35	0.5	V
Output Coding				Twos Complement		

### NOTES

<sup>1</sup>Best dynamic performance is obtained by driving  $\overline{ENC}$  and  $\overline{ENC}$  differentially. See Encoding the AD6640 section for more details. Performance versus  $\overline{ENC}/\overline{ENC}$  power is shown in Figure 18 under Typical Performance Characteristics.

<sup>2</sup>For dc-coupled applications, Encode Input Common-Mode Range specifies the common-mode range the encode inputs can tolerate when driven differentially by minimum differential input voltage of 0.4 V p-p. For differential input voltage swings greater than 0.4 V p-p, the common-mode range will change. The minimum value insures that the input voltage on either encode pin does not go below 0 V. The maximum value insures that the input voltage on either encode pin does not go below 2.0 V or above  $AV_{CC}$  (e.g., for a differential input swing of 0.8 V, the min and max common-mode specs become 0.4 V and 2.4 V respectively).

<sup>3</sup> $\overline{ENC}$  or  $\overline{ENC}$  may be driven alone if desired, but performance will likely be degraded. Logic Compatibility specifications are provided to show that TTL or CMOS clock sources will work. When driving only one encode input, bypass the complementary input to GND with 0.01 μF.

<sup>4</sup>Digital output load is one LCX gate.

Specifications subject to change without notice.

## SWITCHING SPECIFICATIONS<sup>1</sup> ( $AV_{CC} = +5\text{ V}$ , $DV_{CC} = +3.3\text{ V}$ ; ENCODE & $\overline{\text{ENCODE}} = 65\text{ MSPS}$ ; $T_{\text{MIN}} = -40^{\circ}\text{C}$ , $T_{\text{MAX}} = +85^{\circ}\text{C}$ )

Parameter (Conditions)	Temp	Test Level	AD6640AST			Units
			Min	Typ	Max	
Maximum Conversion Rate	Full	VI	65			MSPS
Minimum Conversion Rate <sup>2</sup>	Full	IV			6.5	MSPS
Aperture Delay ( $t_A$ )	+25°C	V		400		ps
Aperture Uncertainty (Jitter)	+25°C	V		0.3		ps rms
ENCODE Pulswidth High <sup>3</sup>	+25°C	IV	6.5			ns
ENCODE Pulswidth Low	+25°C	IV	6.5			ns
Output Delay ( $t_{OD}$ ) $DV_{CC} +3.3\text{ V}/5.0\text{ V}$ <sup>4</sup>	Full	IV	8.5	10.5	12.5	ns

## NOTES

<sup>1</sup>All switching specifications tested by driving ENCODE and  $\overline{\text{ENCODE}}$  differentially.

<sup>2</sup>A plot of Performance vs. Encode is shown in Figure 16 under Typical Performance Characteristics.

<sup>3</sup>A plot of Performance vs. Duty Cycle (Encode = 65 MSPS) is shown in Figure 17 under Typical Performance Characteristics.

<sup>4</sup>Outputs driving one LCX gate. Delay is measured from differential crossing of ENC,  $\overline{\text{ENC}}$  to the time when all output data bits are within valid logic levels.

Specifications subject to change without notice.

## AC SPECIFICATIONS<sup>1</sup> ( $AV_{CC} = +5\text{ V}$ , $DV_{CC} = +3.3\text{ V}$ ; ENCODE & $\overline{\text{ENCODE}} = 65\text{ MSPS}$ ; $T_{\text{MIN}} = -40^{\circ}\text{C}$ , $T_{\text{MAX}} = +85^{\circ}\text{C}$ )

Parameter (Conditions)	Temp	Test Level	AD6640AST			Units
			Min	Typ	Max	
SNR						
Analog Input 2.2 MHz	+25°C	V		68		dB
@ -1 dBFS 15.5 MHz	+25°C	I	64	67.7		dB
31.0 MHz	+25°C	V		67.5		dB
69.0 MHz	+25°C	V		66		dB
SINAD						
Analog Input 2.2 MHz	+25°C	V		68		dB
@ -1 dBFS 15.5 MHz	+25°C	I	63.5	67.2		dB
31.0 MHz	+25°C	V		67.0		dB
69.0 MHz	+25°C	V		65.5		dB
Worst Harmonic <sup>2</sup> (2nd or 3rd)						
Analog Input 2.2 MHz	+25°C	V		80		dBc
@ -1 dBFS 15.5 MHz	+25°C	I	74	80		dBc
31.0 MHz	+25°C	V		79.5		dBc
69.0 MHz	+25°C	V		78.5		dBc
Worst Harmonic <sup>2</sup> (4th or Higher)						
Analog Input 2.2 MHz	+25°C	V		85		dBc
@ -1 dBFS 15.5 MHz	+25°C	I	74	85		dBc
31.0 MHz	+25°C	V		85		dBc
69.0 MHz	+25°C	V		84		dBc
Multitone SFDR (w/Dither) <sup>3</sup>						
Eight Tones @ -20 dBFS	Full	V		90		dBFS
Two-Tone IMD Rejection <sup>4</sup>						
F1, F2 @ -7 dBFS	Full	V		80		dBc
Analog Input Bandwidth <sup>5</sup>	+25°C	V		300		MHz

## NOTES

<sup>1</sup>All ac specifications tested by driving ENCODE and  $\overline{\text{ENCODE}}$  differentially.

<sup>2</sup>For a single test tone at -1 dBFS, the worst case spectral performance is typically limited by the direct or aliased 2nd or 3rd harmonic. If a system is designed such that the 2nd and 3rd harmonics fall out-of-band, overall performance in the band of interest is typically improved by 5 dB. Worst Harmonic (4th or Higher) includes 4th and higher order harmonics and all other spurious components. Reference Figure 12 for more detail.

<sup>3</sup>See Overcoming Static Nonlinearities with Dither section for details on improving SFDR performance. To measure SFDR, eight tones from 14 MHz to 18 MHz (0.5 MHz spacing) are swept from -20 dBFS to -90 dBFS. An open channel at 16 MHz is used to monitor SFDR.

<sup>4</sup>F1 = 14.9 MHz, F2 = 16 MHz.

<sup>5</sup>Specification is small signal bandwidth. Plots of Performance versus Analog Input Frequency are shown in Figures 10, 11 and 12. Sampling wide bandwidths (5 MHz-15 MHz) should be limited to 70 MHz center frequency.

Specifications subject to change without notice.

# AD6640

## ABSOLUTE MAXIMUM RATINGS<sup>1</sup>

Parameter	Min	Max	Units
<b>ELECTRICAL</b>			
$V_{CC}$ Voltage	0	7	V
$DV_{CC}$ Voltage	0	7	V
Analog Input Voltage	0	$V_{CC}$	V
Analog Input Current		25	mA
Digital Input Voltage (ENCODE)	0	$V_{CC}$	V
Digital Output Current	-10	10	mA
<b>ENVIRONMENTAL<sup>2</sup></b>			
Operating Temperature Range (Ambient)	-40	+85	°C
Maximum Junction Temperature		+150	°C
Lead Temperature (Soldering, 10 sec)		+300	°C
Storage Temperature Range (Ambient)	-65	+150	°C

### NOTES

<sup>1</sup>Absolute maximum ratings are limiting values to be applied individually, and beyond which the serviceability of the circuit may be impaired. Functional operability is not necessarily implied. Exposure to absolute maximum rating conditions for an extended period of time may affect device reliability.

<sup>2</sup>Typical thermal impedances (44-terminal TQFP);  $\theta_{JA} = 55^{\circ}\text{C}/\text{W}$ .

## EXPLANATION OF TEST LEVELS

### Test Level

- I - 100% production tested.
- II - 100% production tested at +25°C, and sample tested at specified temperatures. AC testing done on sample basis.
- III - Sample tested only.
- IV - Parameter is guaranteed by design and characterization testing.
- V - Parameter is a typical value only.
- VI - All devices are 100% production tested at +25°C; sample tested at temperature extremes.

## ORDERING GUIDE

Model	Temperature Range	Package Description	Package Option
AD6640AST	-40°C to +85°C (Ambient)	44-Terminal TQFP (Thin Quad Plastic Flatpack)	ST-44
AD6640ST/PCB		Evaluation Board with AD6640AST	

## CAUTION

ESD (electrostatic discharge) sensitive device. Electrostatic charges as high as 4000 V readily accumulate on the human body and test equipment and can discharge without detection. Although the AD6640 features proprietary ESD protection circuitry, permanent damage may occur on devices subjected to high energy electrostatic discharges. Therefore, proper ESD precautions are recommended to avoid performance degradation or loss of functionality.



PIN FUNCTION DESCRIPTIONS

Pin No.	Name	Function
1, 2, 36, 37, 40, 41	DV <sub>CC</sub>	+3.3 V/+5 V Power Supply (Digital). Powers output stage only.
3	ENCODE	Encode Input. Data conversion initiated on rising edge.
4	$\overline{\text{ENCODE}}$	Complement of ENCODE. Drive differentially with ENCODE or bypass to Ground for single-ended clock mode. See Encoding the AD6640 section.
5, 6, 13, 14, 17, 18, 21, 22, 24, 34, 35, 38, 39	GND	Ground.
7	AIN	Analog Input.
8	$\overline{\text{AIN}}$	Complement of Analog Input.
9	V <sub>REF</sub>	Internal Voltage Reference. Nominally +2.4 V. Bypass to Ground with 0.1 $\mu\text{F}$ + 0.01 $\mu\text{F}$ microwave chip capacitor.
10	C1	Internal Bias Point. Bypass to ground with 0.01 $\mu\text{F}$ capacitor.
11, 12, 15, 16, 19, 20	AV <sub>CC</sub>	+5 V Power Supply (Analog).
23	NC	No Connect.
25	D0 (LSB)	Digital Output Bit (Least Significant Bit).
26-33	D1-D8	Digital Output Bits.
42, 43	D9-D10	Digital Output Bits.
44	$\overline{\text{D11}}$ (MSB) <sup>1</sup>	Digital Output Bit (Most Significant Bit).

NOTE

<sup>1</sup>Output coded as twos complement.

PIN CONFIGURATION

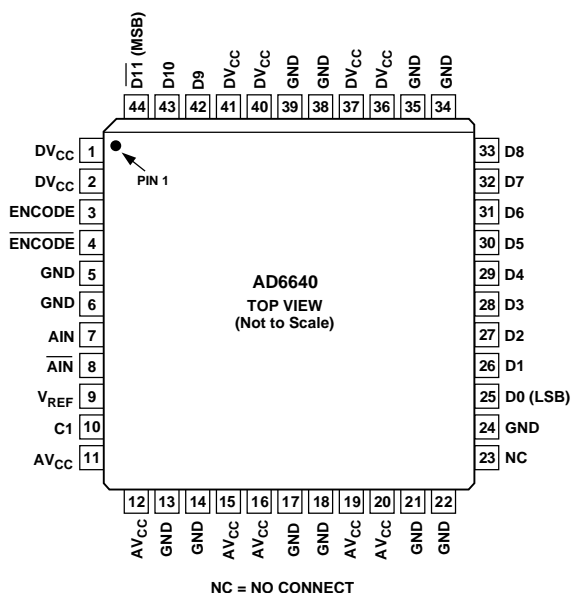

# AD6640

## DEFINITION OF SPECIFICATIONS

### Analog Bandwidth (Small Signal)

The analog input frequency at which the spectral power of the fundamental frequency (as determined by the FFT analysis) is reduced by 3 dB.

### Aperture Delay

The delay between a differential crossing of ENCODE and  $\overline{\text{ENCODE}}$  and the instant at which the analog input is sampled.

### Aperture Uncertainty (Jitter)

The sample-to-sample variation in aperture delay.

### Differential Nonlinearity

The deviation of any code from an ideal 1 LSB step.

### Encode Pulsewidth/Duty Cycle

Pulsewidth high is the minimum amount of time that the ENCODE pulse should be left in logic "1" state to achieve rated performance; pulsewidth low is the minimum time ENCODE pulse should be left in low state. At a given clock rate, these specs define an acceptable Encode duty cycle.

### Integral Nonlinearity

The deviation of the transfer function from a reference line measured in fractions of 1 LSB using a "best straight line" determined by a least square curve fit.

### Minimum Conversion Rate

The encode rate at which the SNR of the lowest analog signal frequency drops by no more than 3 dB below the guaranteed limit.

### Maximum Conversion Rate

The encode rate at which parametric testing is performed.

### Output Propagation Delay

The delay between a differential crossing of ENCODE and  $\overline{\text{ENCODE}}$  and the time when all output data bits are within valid logic levels.

### Power Supply Rejection Ratio

The ratio of a change in input offset voltage to a change in power supply voltage.

### Signal-to-Noise-and-Distortion (SINAD)

The ratio of the rms signal amplitude (set at 1 dB below full scale) to the rms value of the sum of all other spectral components, including harmonics but excluding dc.

### Signal-to-Noise Ratio (SNR)

The ratio of the rms signal amplitude (set at 1 dB below full scale) to the rms value of the sum of all other spectral components, excluding the first five harmonics and dc.

### Spurious-Free Dynamic Range (SFDR)

The ratio of the rms signal amplitude to the rms value of the peak spurious spectral component. The peak spurious component may or may not be a harmonic. May be reported in dBc (i.e., degrades as signal levels is lowered), or in dBFS (always related back to converter full scale).

### Two-Tone Intermodulation Distortion Rejection

The ratio of the rms value of either input tone to the rms value of the worst third order intermodulation product; reported in dBc.

### Two-Tone SFDR

The ratio of the rms value of either input tone to the rms value of the peak spurious component. The peak spurious component may or may not be an IMD product. May be reported in dBc (i.e., degrades as signal levels is lowered), or in dBFS (always related back to converter full scale).

### Worst Harmonic

The ratio of the rms signal amplitude to the rms value of the worst harmonic component, reported in dBc.

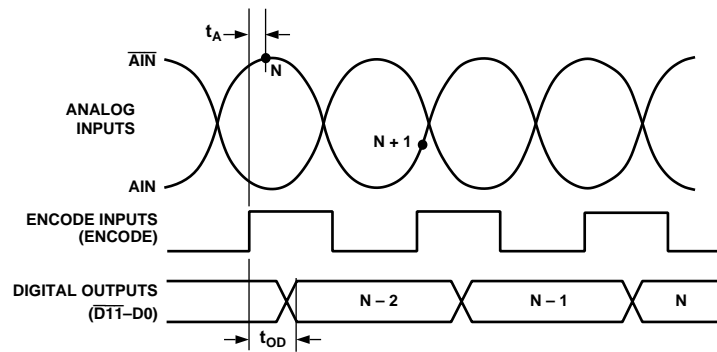

Figure 1. Timing Diagram

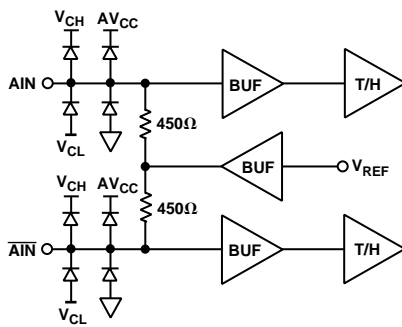

Figure 2. Analog Input Stage

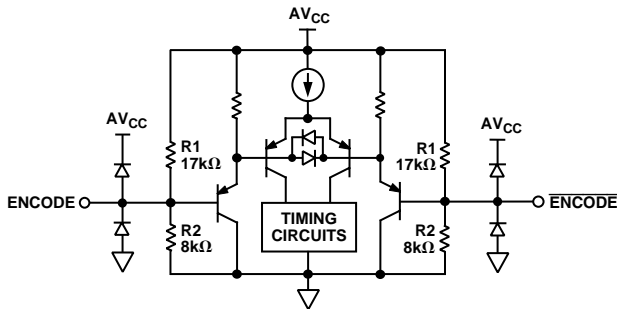

Figure 3. Encode Inputs

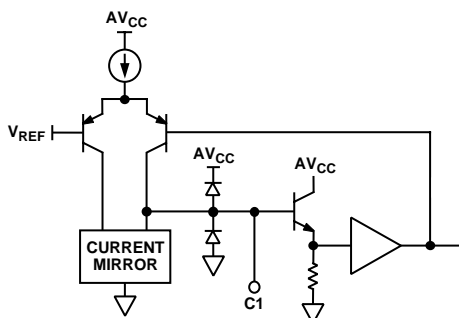

Figure 4. Compensation Pin, C1

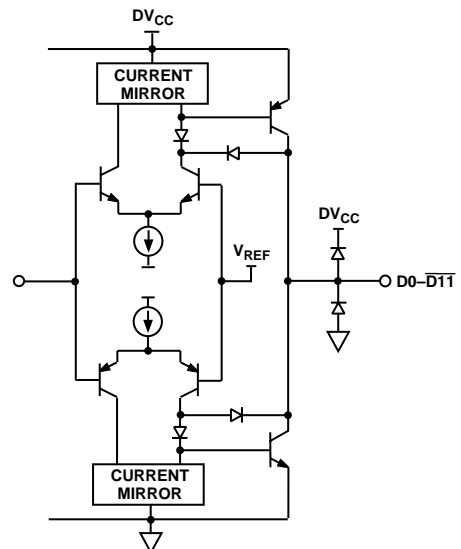

Figure 5. Digital Output Stage

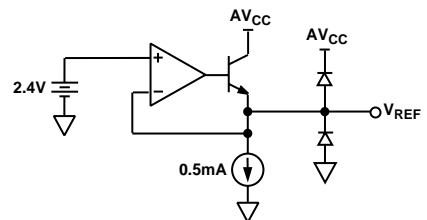

Figure 6. 2.4 V Reference

# AD6640—Typical Performance Characteristics

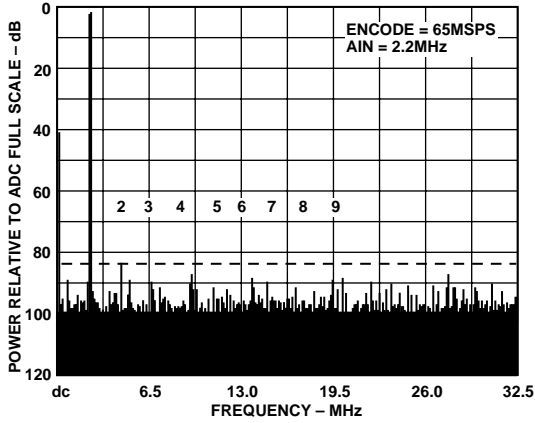

Figure 7. Single Tone at 2.2 MHz

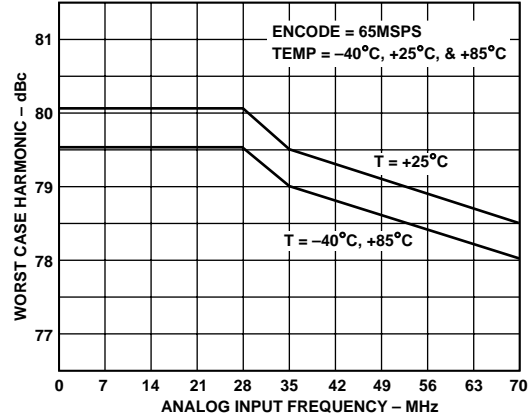

Figure 10. Harmonics vs. AIN

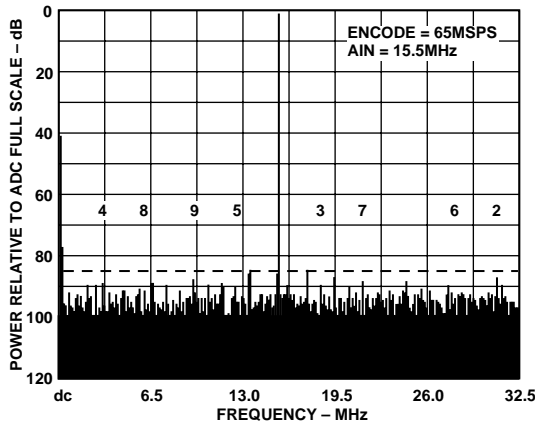

Figure 8. Single Tone at 15.5 MHz

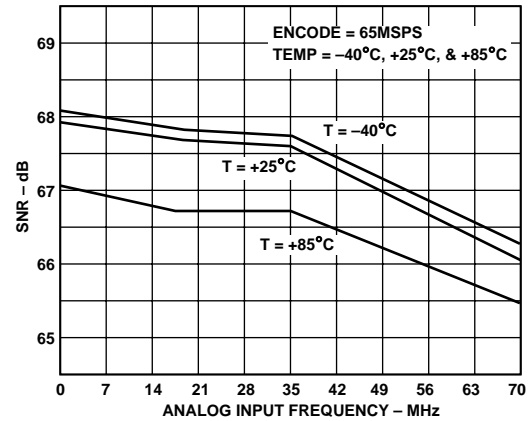

Figure 11. Noise vs. AIN

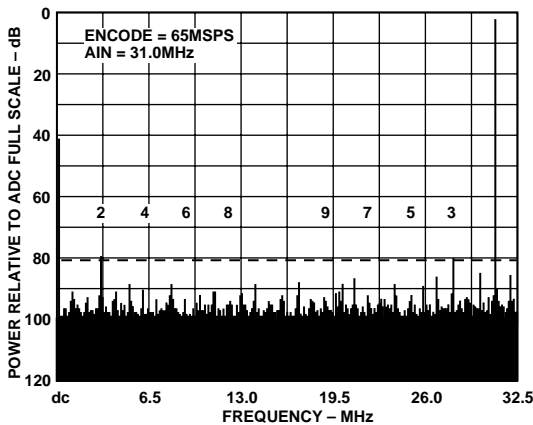

Figure 9. Single Tone at 31.0 MHz

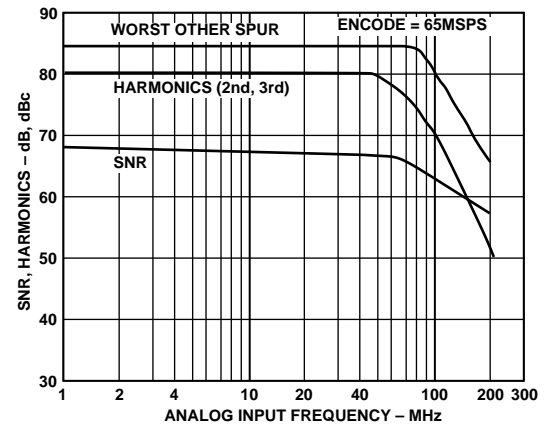

Figure 12. Harmonics, Noise vs. AIN

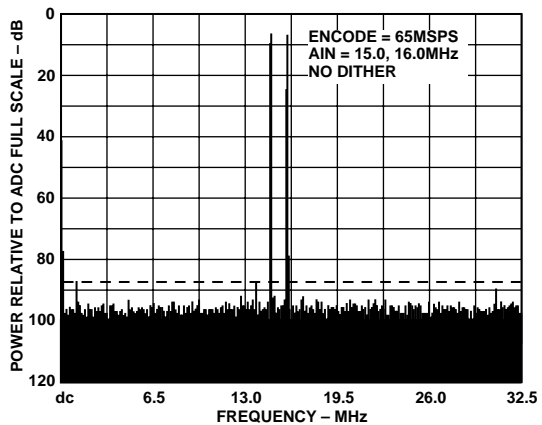

Figure 13. Two Tones at 15.0 MHz & 16.0 MHz

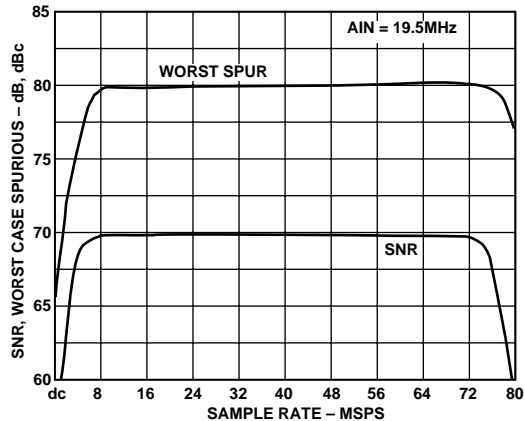

Figure 16. SNR, Worst Spurious vs. Encode

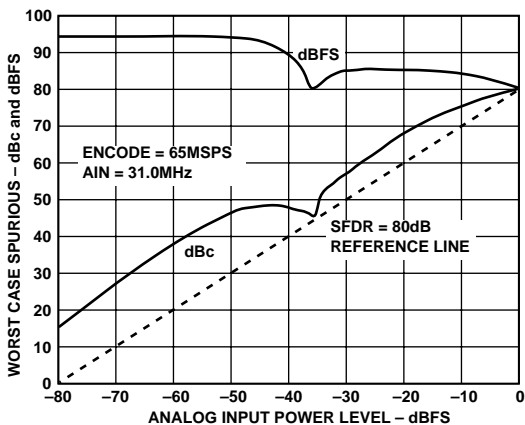

Figure 14. Single Tone SFDR

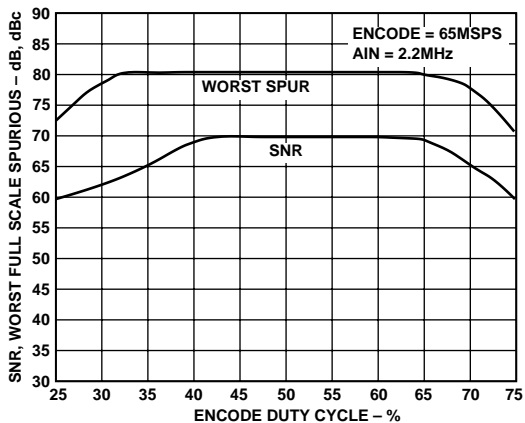

Figure 17. SNR, Worst Spurious vs. Duty Cycle

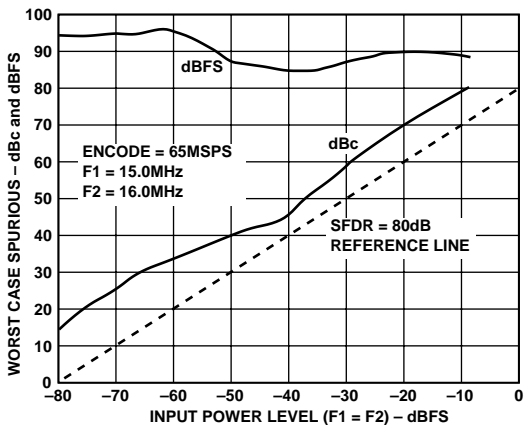

Figure 15. Two Tone SFDR

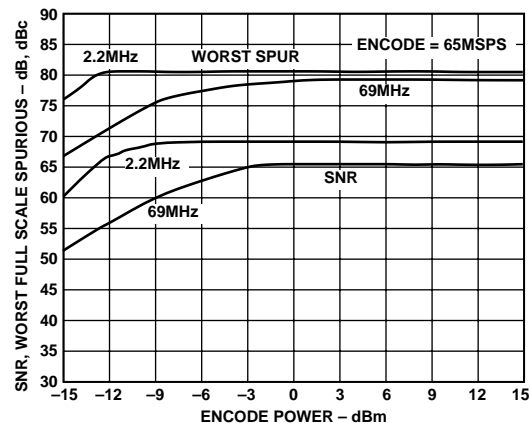

Figure 18. SNR, Worst Spurious vs. Encode Power

# AD6640

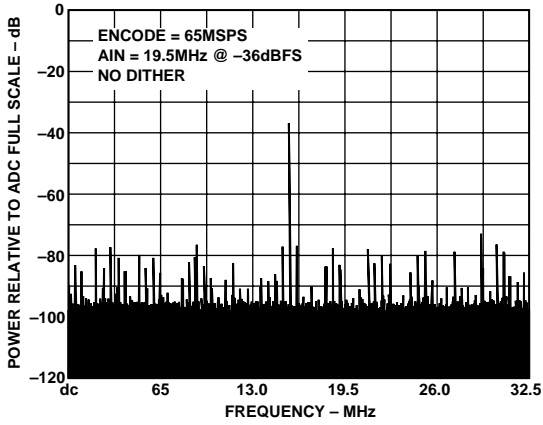

Figure 19. 16K FFT without Dither

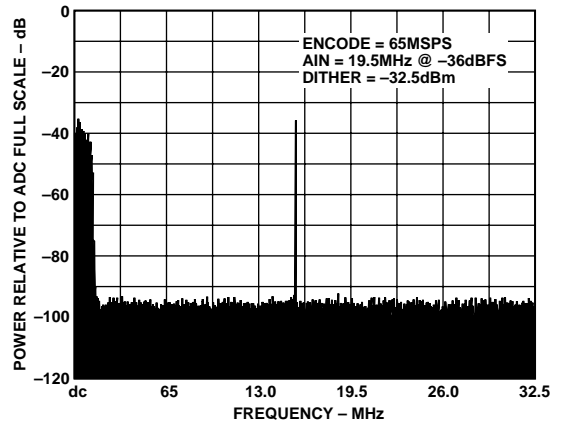

Figure 22. 16K FFT with Dither

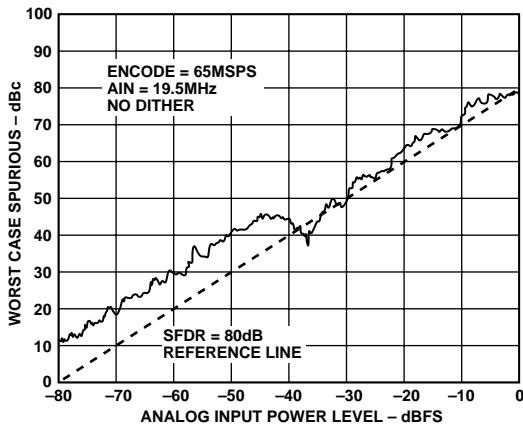

Figure 20. SFDR without Dither

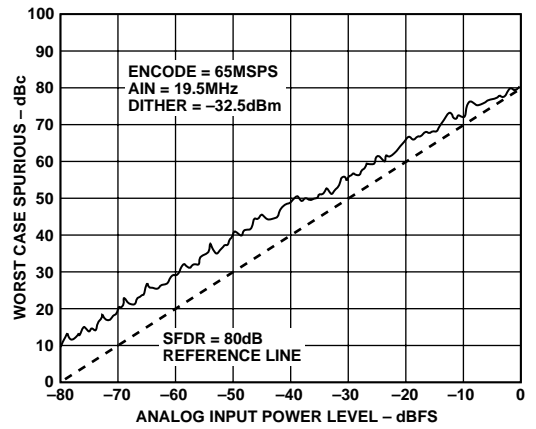

Figure 23. SFDR with Dither

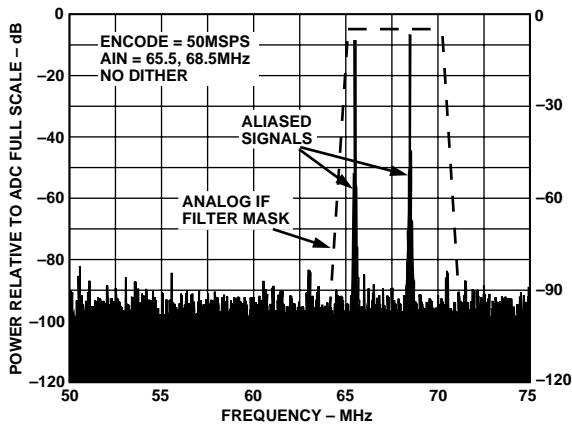

Figure 21. IF-Sampling at 70 MHz without Dither

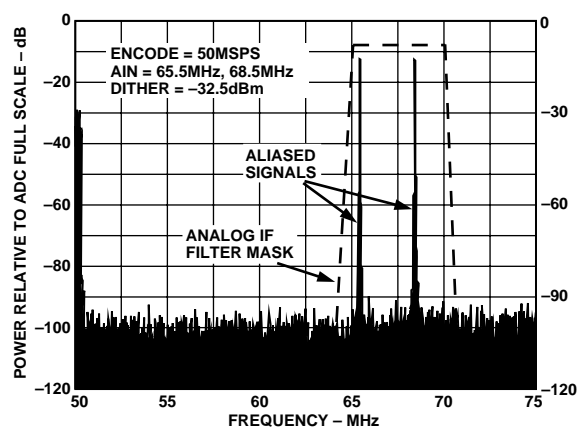

Figure 24. IF-Sampling at 70 MHz with Dither

## THEORY OF OPERATION

The AD6640 analog-to-digital converter (ADC) employs a two-stage subrange architecture. This design approach ensures 12-bit accuracy, without the need for laser trim, at low power.

As shown in the functional block diagram, the AD6640 has complementary analog input pins,  $\overline{\text{AIN}}$  and  $\text{AIN}$ . Each analog input is centered at 2.4 volts and should swing  $\pm 0.5$  volts around this reference (ref. Figure 2). Since  $\text{AIN}$  and  $\overline{\text{AIN}}$  are 180 degrees out of phase, the differential analog input signal is 2 volts peak-to-peak.

Both analog inputs are buffered prior to the first track-and-hold, TH1. The high state of the ENCODE pulse places TH1 in hold mode. The held value of TH1 is applied to the input of a 6-bit coarse ADC. The digital output of the coarse ADC drives a 6-bit DAC; the DAC is 12 bits accurate. The output of the 6-bit DAC is subtracted from the delayed analog signal at the input of TH3 to generate a residue signal. TH2 is used as an analog pipeline to null out the digital delay of the coarse ADC.

The 6-bit coarse ADC word and 7-bit residue word are added together and corrected in the digital error correction logic to generate the output word. The result is a 12-bit parallel digital CMOS-compatible word, coded as two's complement.

## APPLYING THE AD6640

### Encoding the AD6640

Best performance is obtained by driving the encode pins differentially. However, the AD6640 is also designed to interface with TTL and CMOS logic families. The source used to drive the ENCODE pin(s) must be clean and free from jitter. Sources with excessive jitter will limit SNR (reference Equation 1 under "Noise Floor and SNR").

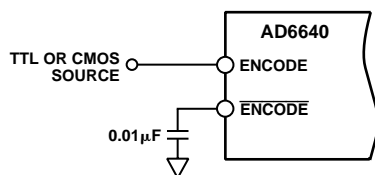

Figure 25. Single-Ended TTL/CMOS Encode

The AD6640 encode inputs are connected to a differential input stage (see Figure 3 under EQUIVALENT CIRCUITS). With no input signal connected to either ENCODE pin, the voltage dividers bias the inputs to 1.6 volts. For TTL or CMOS usage, the encode source should be connected to ENCODE, Pin 3.  $\overline{\text{ENCODE}}$  should be decoupled using a low inductance or microwave chip capacitor to ground.

If a logic threshold other than the nominal 1.6 V is required, the following equations show how to use an external resistor,  $R_x$ , to raise or lower the trip point (see Figure 3;  $R_1 = 17 \text{ k}\Omega$ ,  $R_2 = 8 \text{ k}\Omega$ ).

$$V_I = \frac{5R_2R_x}{R_1R_2 + R_1R_x + R_2R_x} \text{ to lower logic threshold.}$$

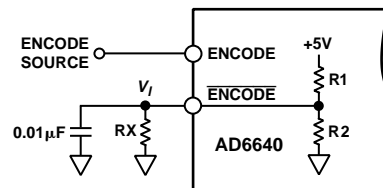

Figure 26. Lower Logic Threshold for Encode

$$V_I = \frac{5R_2}{R_2 + \frac{R_1R_x}{R_1 + R_x}} \text{ to raise logic threshold.}$$

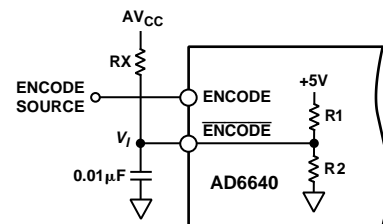

Figure 27. Raise Logic Threshold for Encode

While the single-ended encode will work well for many applications, driving the encode differentially will provide increased performance. Depending on circuit layout and system noise, a 1 dB to 3 dB improvement in SNR can be realized. It is not recommended that differential TTL logic be used however, because most TTL families that support complementary outputs are not delay or slew rate matched. Instead, it is recommended that the encode signal be ac-coupled into the ENCODE and  $\overline{\text{ENCODE}}$  pins.

The simplest option is shown below. The low jitter TTL signal is coupled with a limiting resistor, typically 100 ohms, to the primary side of an RF transformer (these transformers are inexpensive and readily available; part number in Figure 28 is from Mini-Circuits). The secondary side is connected to the ENCODE and  $\overline{\text{ENCODE}}$  pins of the converter. Since both encode inputs are self-biased, no additional components are required.

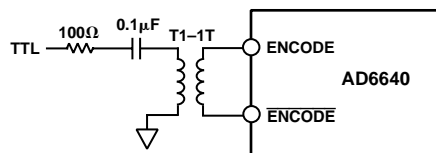

Figure 28. TTL Source - Differential Encode

A clean sine wave may be substituted for a TTL clock. In this case, the matching network is shown below. Select a transformer ratio to match source and load impedances. The input impedance of the AD6640 encode is approximately 11 k $\Omega$  differentially. Therefore "R," shown in the Figure 29, may be any value that is convenient for available drive power.

# AD6640

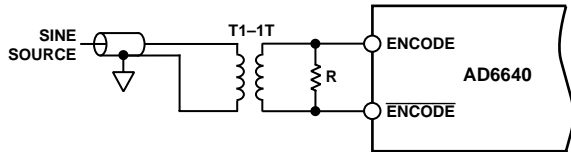

Figure 29. Sine Source - Differential Encode

If a low jitter ECL clock is available, another option is to ac-couple a differential ECL signal to the encode input pins as shown below. The capacitors shown here should be chip capacitors but do not need to be of the low inductance variety.

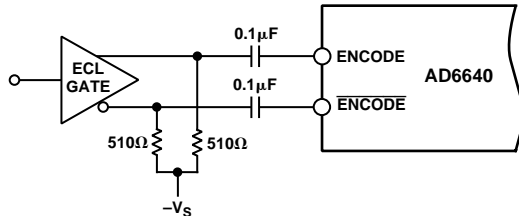

Figure 30. Differential ECL for Encode

As a final alternative, the ECL gate may be replaced by an ECL comparator. The input to the comparator could then be a logic signal or a sine signal.

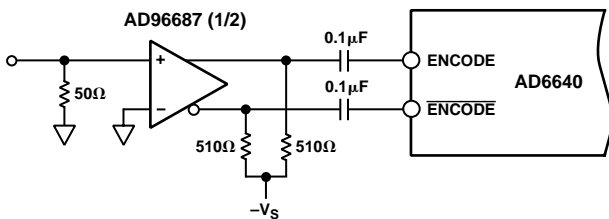

Figure 31. ECL Comparator for Encode

## Driving the Analog Input

Because the AD6640 operates from a single +5 volt supply, the analog input voltage range is offset from ground by 2.4 volt. Each analog input connects through a 450 ohm resistor to the 2.4 volt bias voltage and to the input of a differential buffer (Figure 32). This resistor network on the input properly biases the followers for maximum linearity and range. Therefore, the analog source driving the AD6640 should be ac-coupled to the input pins. Since the differential input impedance of the AD6640 is 0.9 k $\Omega$ , the analog input power requirement is only -3 dBm, simplifying the drive amplifier in many cases.

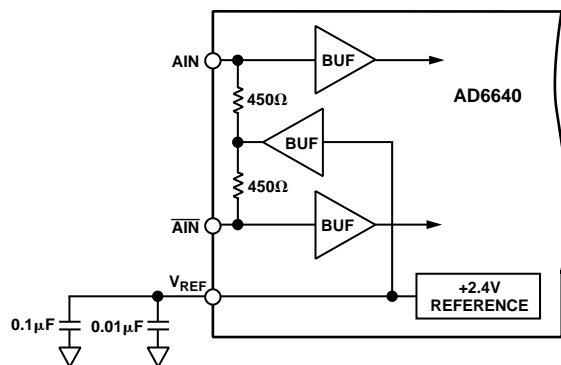

Figure 32. Differential Analog Inputs

To take full advantage of this high input impedance, a 20:1 transformer would be required. This is a large ratio and could result in unsatisfactory performance. In this case, a lower step-up ratio could be used. For example, if  $R_T$  were set to 260 ohms, along with a 4:1 transformer, the input would match to a 50 ohm source with a full-scale drive of +4 dBm (Figure 33). Note that the external load resistor,  $R_T$ , is in parallel with the AD6640 analog input resistance of 900 ohms. The external resistor value can be calculated from the following equation:

$$R_T = \frac{1}{\frac{1}{Z} - \frac{1}{900}}$$

where  $Z$  is the desired impedance (200  $\Omega$  for a 4:1 transformer with 50  $\Omega$  input source).

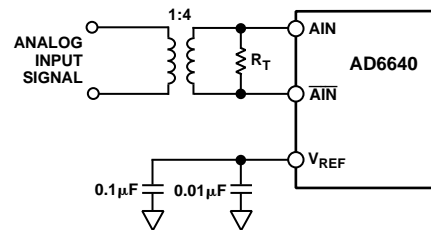

Figure 33. Transformer-Coupled Analog Input Signal

If the lower drive power is attractive, a combination transformer match and LC match could be employed that would use a 4:1 transformer with an LC as shown in Figure 34. This solution is useful when good performance in the third Nyquist zone is required. Such a requirement arises when digitizing high intermediate frequencies in communications receivers.

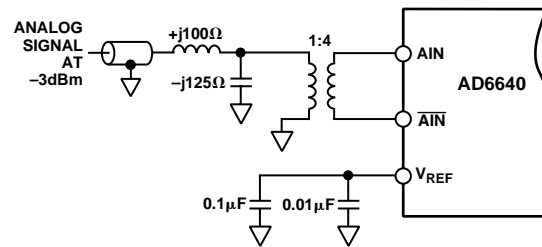

Figure 34. Low Power Drive Circuit

In applications where gain is needed but dc-coupling is not necessary, an extension of Figure 34 is recommended. A 50 ohm gain block may be placed in front of the LC matching network. Such gain blocks are readily available for commercial applications. These low cost modules can have excellent NF and intermodulation performance. This circuit is especially good for the "IF" receiver application previously mentioned.

In applications where dc-coupling is required the following circuit can be used (Figure 35). It should be noted that the addition of circuitry for dc-coupling may compromise performance in terms of noise, offset and dynamic performance. This circuit requires an inverting and noninverting signal path. Additionally, an offset must be generated so that the analog input to each pin is centered near 2.4 volts. Since the input is differential, small differences in the dc voltage at each input can translate into an offset for the circuit. The same holds true for gain mismatch. Therefore, some means of adjusting the gain and offset between



# AD6640

The analog input range of the PCB is  $\pm 0.5$  volts (i.e., signal ac-coupled to AD6640).

The encode signal may be generated using an onboard crystal oscillator, U1. The oscillator is socketed and may be replaced by an external encode source via J1. If an external source is used, it should be a high quality TTL source. A transformer converts the single-ended TTL signal to a differential clock (see Encoding the AD6640). Since the encode is coupled with a transformer, a sine wave could have been used; note, however, that U5 requires TTL levels to function properly.

AD6640 output data is latched using 74LCX574 (U3, U4) latches following 348 ohm series resistors. The resistors limit the current that would otherwise flow due to the digital output slew rate. The resistor value was chosen to represent a time constant of ~25% of the data rate at 65 MHz. This reduces slew rate while not appreciably distorting the data waveform. Data is latched in a pipeline configuration; a rising edge generates the new AD6640 data sample, latches the previous data at the converter output, and strobes the external data register over J3.

NOTE: Power and ground must be applied to J3 to power the digital logic section of the evaluation board.

**Table I. AD6640ST/PCB Bill of Material**

Item	Quantity	Reference	Description
1	2	+5 VA, GND	Banana Jack
2	11	C7-C9, C11-C17, C19	Ceramic Chip Capacitor 0805, 0.1 $\mu$ F
3	2	C4, C6	Tantalum Chip Capacitor 10 $\mu$ F
4	1	J3	40-Pin Double Row Male Header
5	3	J1, J2, J4	BNC Coaxial PCB Connector
6	1	R1	Surface Mount Resistor 1206, 348 $\Omega$
7	25	R2-R14, R20-R25, R30-R35	Surface Mount Resistor 1206, 348 $\Omega$
8	1	R15	Surface Mount Resistor 1206, 100 $\Omega$
9	1	R16	Surface Mount Resistor 1206, 270 $\Omega$
10	2	T1, T2	Surface Mount Transformer Mini-Circuits T4-1T, 1:4 Ratio
11	1	U1	Clock Oscillator (Optional)
12	1	DUT	AD6640AST 12-Bit-65 MSPS ADC Converter
13	2	U3, U4	74LCX574 Octal Latch
14	1	U5	74LVQ00 Quad Two Input NAND Gate
15	1	C1, C18	Ceramic Chip Capacitor 0508, 0.01 $\mu$ F Low Inductance
16	2	C2, C3	Ceramic Chip Capacitor 0508, 0.1 $\mu$ F Low Inductance
17	2	CR1, CR2	1N2810 Schottky Diode

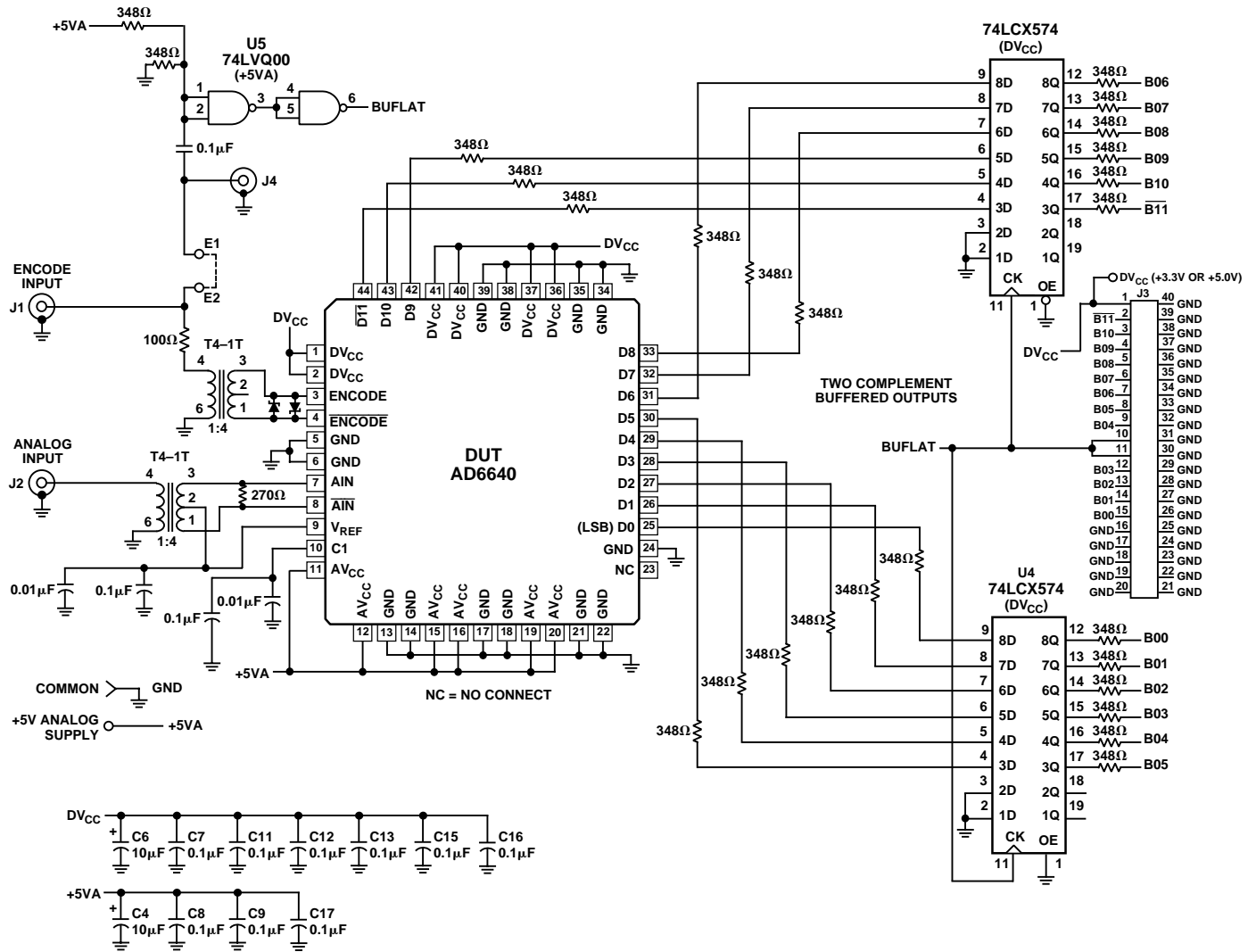

Figure 36. AD6640ST/PCB Schematic

# AD6640

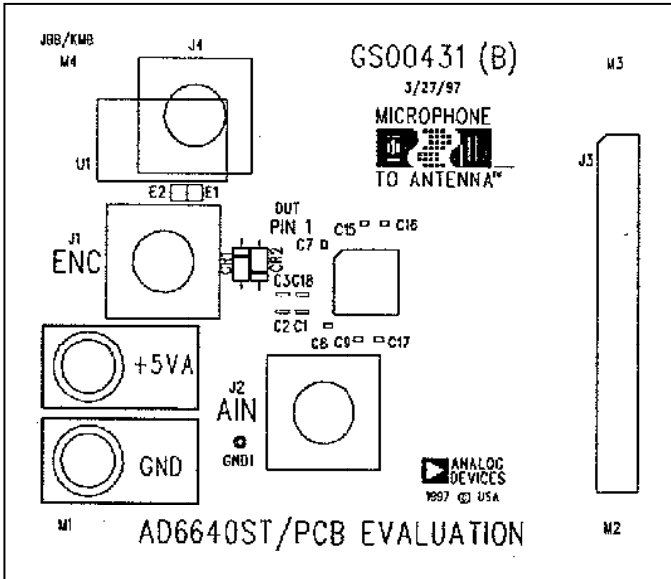

Figure 37. AD6640ST/PCB Top Side Silkscreen

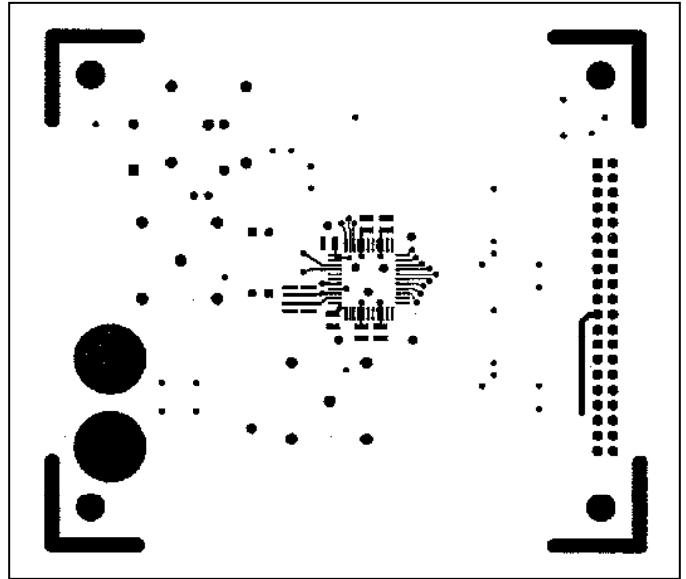

Figure 39. AD6640ST/PCB Top Side Copper

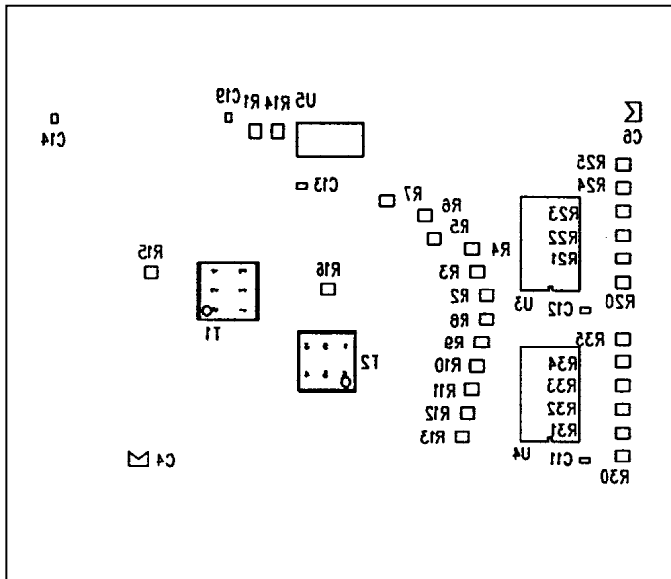

Figure 38. AD6640ST/PCB Bottom Side Silkscreen

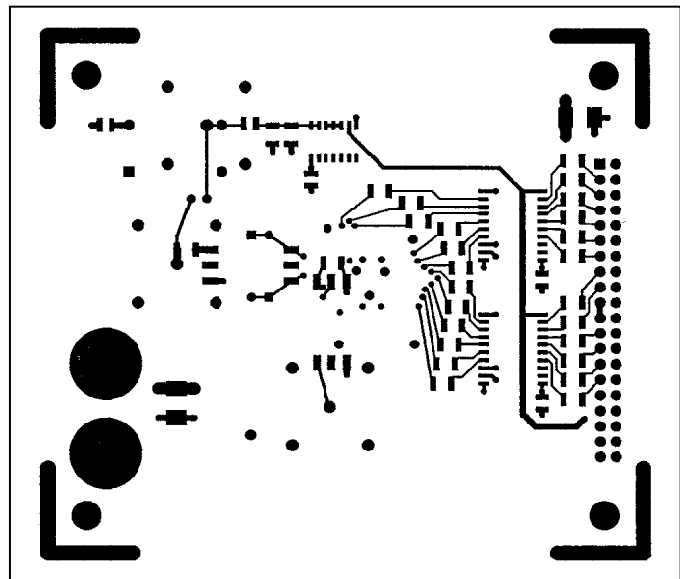

Figure 40. AD6640ST/PCB Bottom Side Copper (Positive)

NOTE: Evaluation boards are often updated, consult factory for latest version.

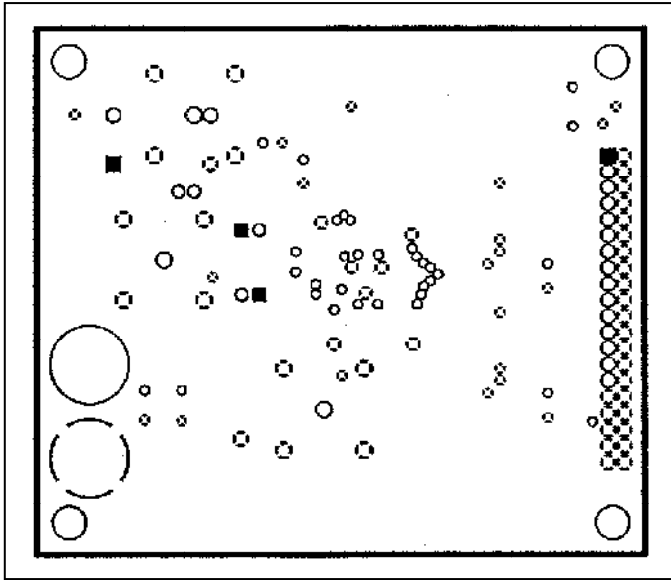

Figure 41. AD6640ST/PCB Ground Layer (Negative)

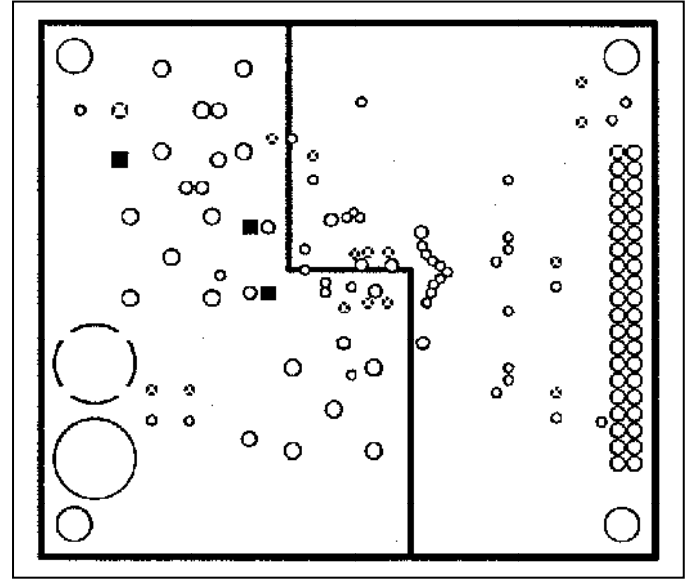

Figure 42. AD6640ST/PCB "Split" Power Layer (Negative)

# AD6640

## DIGITAL WIDEBAND RECEIVERS

### Introduction

Several key technologies are now being introduced that may forever alter the vision of radio. Figure 43 shows the typical dual conversion superheterodyne receiver. The signal picked up by the antenna is mixed down to an intermediate frequency (IF) using a mixer with a variable local oscillator (LO); the variable LO is used to “tune-in” the desired signal. This first IF is mixed down to a second IF using another mixer stage and a fixed LO. Demodulation takes place at the second or third IF using either analog or digital techniques.

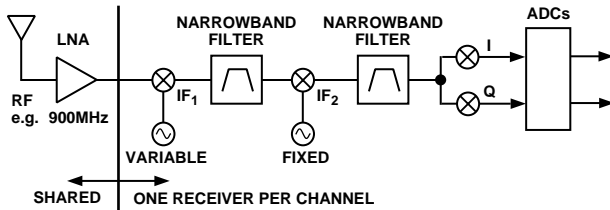

Figure 43. Narrowband Digital Receiver Architecture

If demodulation takes place in the analog domain then traditional discriminators, envelop detectors, phase locked loops or other synchronous detectors are generally employed to strip the modulation from the selected carrier.

However, as general purpose DSP chips such as the ADSP-2181 become more popular, they will be used in many baseband-sampled applications like the one shown in Figure 43. As shown in the figure, prior to ADC conversion, the signal must be mixed down, filtered, and the I and Q components separated. These functions are realizable through DSP techniques, however several key technology breakthroughs are required: high dynamic range ADCs such as the AD6640, new DSPs (highly programmable with onboard memory, fast), digital tuners and filters such as the AD6620, wide band mixers and amplifiers.

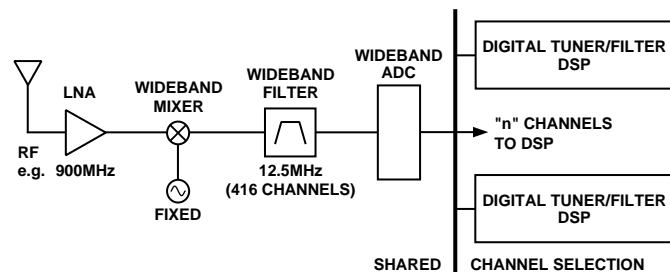

Figure 44. Wideband Digital Receiver Architecture

Figure 44 shows such a wideband system. This design shows that the front end variable local oscillator has been replaced with a fixed oscillator and the back end has been replaced with a wide dynamic range ADC, digital tuner and DSP. This technique offers many benefits.

First, many passive discrete components have been eliminated that formed the tuning and filtering functions. These passive components often require “tweaking” and special handling during assembly and final system alignment. Digital components require no such adjustments; tuner and filter characteristics are always exactly the same. Moreover, the tuning and filtering characteristics can be changed through software. Since software

is used for demodulation, different routines may be used to demodulate different standards such as AM, FM, GMSK or any other desired standard. In addition, as new standards arise or new software revisions are generated, they may be field installed with standard software update channels. A radio that performs demodulation in software as opposed to hardware is often referred to as a soft radio because it may be changed or modified simply through code revision.

### System Description

In the wideband digital radio (Figure 44), the first down conversion functions in much the same way as a block converter does. An entire band is shifted in frequency to the desired intermediate frequency. In the case of cellular base station receivers, 5 MHz to 30 MHz of bandwidth are down-converted simultaneously to an IF frequency suitable for digitizing with a wideband analog-to-digital converter. Once digitized the broadband digital data stream contains all of the in-band signals. The remainder of the radio is constructed digitally using special purpose and general purpose programmable DSP to perform filtering, demodulation and signal conditioning not unlike the analog counter parts.

In the narrowband receiver (Figure 43), the signal to be received must be tuned. This is accomplished by using a variable local oscillator at the first mix down stage. The first IF then uses a narrow band filter to reject out of band signals and condition the selected carrier for signal demodulation.

In the digital wideband receiver (Figure 44), the variable local oscillator has been replaced with a fixed oscillator, so tuning must be accomplished in another manner. Tuning is performed digitally using a digital down conversion and filter chip frequently called a channelizer. The term channelizer is used because the purpose of these chips is to select one channel out of many within the broadband spectrum present in the digital data stream of the ADC.

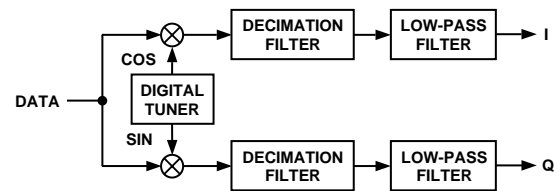

Figure 45. AD6620 Digital Channelizer

Figure 45 shows the block diagram of a typical channelizer, such as the AD6620. Channelizers consist of a complex NCO (Numerically Controlled Oscillator), dual multiplier (mixer), and matched digital filters. These are the same functions that would be required in an analog receiver, however implemented in digital form. The digital output from the channelizer is the desired carrier, frequently in I & Q format; all other signals have been filtered and removed based on the filtering characteristics desired. Since the channelizer output consists of one selected RF channel, one tuner chip is required for each frequency received, although only one wideband RF receiver is needed for the entire band. Data from the channelizer may then be processed using a digital signal processor such as the ADSP-2181 or the SHARC® processor, the ADSP-21062. This data may then be processed through software to demodulate the information from the carrier.

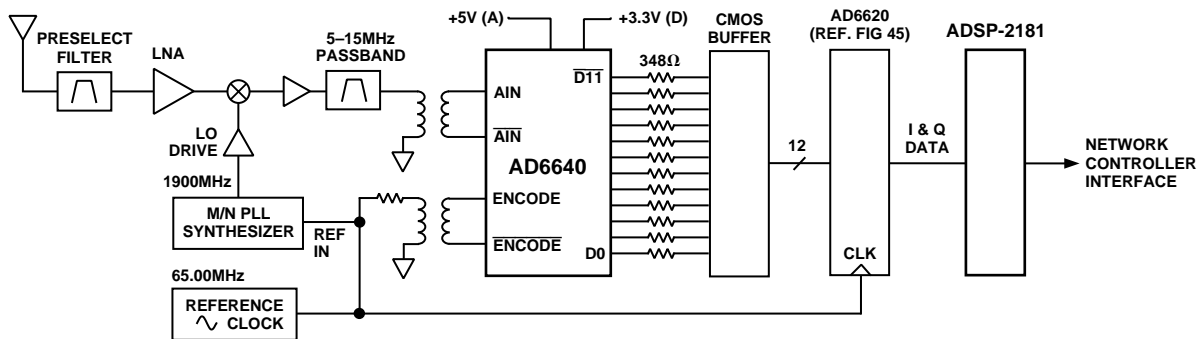

Figure 46. Simplified Wideband PCS Receiver

### System Requirements

Figure 46 shows a typical wideband receiver subsystem based around the AD6640. This strip consists of a wideband IF filter, amplifier, ADC, latches, channelizer and interface to a digital signal processor. This design shows a typical clocking scheme used in many receiver designs. All timing within the system is referenced back to a single clock. While this is not necessary, it does facilitate PLL design, ease of manufacturing, system test, and calibration. Keeping in mind that the overall performance goal is to maintain the best possible dynamic range, many considerations must be made.

One of the biggest challenges is selecting the amplifier used to drive the AD6640. Since this is a communications application, it is common to directly sample an intermediate frequency (IF) signal. As such, IF gain blocks can be implemented instead of baseband op amps. For these gain block amplifiers, the critical specifications are third order intercept point and noise figure. A bandpass filter will remove harmonics generated within the amplifier, but intermods should be better than the performance of the A/D converter. In the case of the AD6640, amplifier intermods must be better than  $-80$  dBFS when driving full-scale power. As mentioned earlier, there are several amplifiers to choose from and the specifications depend on the end application. Figure 47 shows a typical multitone test.

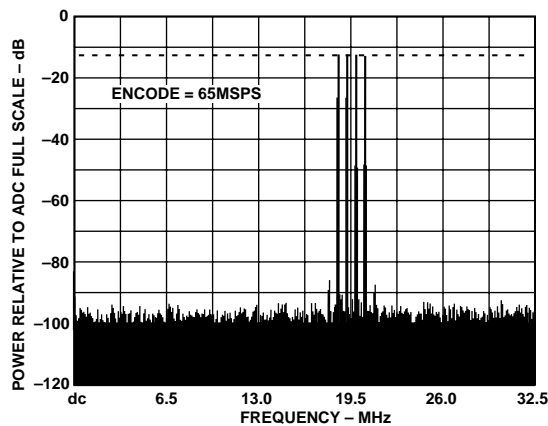

Figure 47. Multitone Performance

Two other key considerations for the digital wideband receiver are converter sample rate and IF frequency range. Since performance of the AD6640 converter is largely independent of both sample rate and analog input frequency (Figures 10, 11 and 16), the designer has greater flexibility in the selection of these parameters. Also, since the AD6640 is a bipolar device,

power dissipation is not a function of sample rate. Thus there is no penalty paid in power by operating at faster sample rates. All of this is good because, by carefully selecting input frequency range and sample rate, some of the drive amplifier and ADC harmonics can actually be placed out-of-band.

For example, if the system has second and third harmonics that are unacceptably high, by carefully selecting the encode rate and signal bandwidth, these second and third harmonics can be placed out-of-band. For the case of an encode rate equal to 60 MSPS and a signal bandwidth of 7.5 MHz, placing the fundamental at 7.5 MHz places the second and third harmonics out of band as shown in the table below.

Table II.

Encode Rate	60 MSPS
Fundamental	7.5 MHz–15 MHz
Second Harmonic	15 MHz–30 MHz
Third Harmonic	22.5 MHz–30 MHz, 30 MHz–15 MHz

Another option can be found through bandpass sampling. If the analog input signal range is from dc to  $FS/2$ , then the amplifier and filter combination must perform to the specification required. However, if the signal is placed in the third Nyquist zone ( $FS$  to  $3FS/2$ ), the amplifier is no longer required to meet the harmonic performance required by the system specifications since all harmonics would fall outside the passband filter. For example, the passband filter would range from  $FS$  to  $3FS/2$ . The second harmonic would span from  $2FS$  to  $3FS$ , well outside the passband filter's range. The burden then has been passed off to the filter design provided that the ADC meets the basic specifications at the frequency of interest. In many applications, this is a worthwhile tradeoff since many complex filters can easily be realized using SAW and LCR techniques alike at these relatively high IF frequencies. Although harmonic performance of the drive amplifier is relaxed by this technique, intermodulation performance cannot be sacrificed since intermods must be assumed to fall in-band for both amplifiers and converters.

### Noise Floor and SNR

Oversampling is sampling at a rate that is greater than twice the bandwidth of the signal desired. Oversampling does not have anything to do with the actual frequency of the sampled signal, it is the bandwidth of the signal that is key. Bandpass or "IF" sampling refers to sampling a frequency that is higher than Nyquist and often provides additional benefits such as down conversion using the ADC and replacing a mixer with a track-and-hold. Oversampling leads to processing gains because the

# AD6640

faster the signal is digitized, the wider the distribution of noise. Since the integrated noise must remain constant, the actual noise floor is lowered by 3 dB each time the sample rate is doubled. The effective noise density for an ADC may be calculated by the equation:

$$V_{NOISE\ rms} / \sqrt{Hz} = \frac{10^{-SNR/20}}{\sqrt{4 FS}}$$

For a typical SNR of 68 dB and a sample rate of 65 MSPS, this is equivalent to 25 nV/ $\sqrt{Hz}$ . This equation shows the relationship between SNR of the converter and the sample rate FS. This equation may be used for computational purposes to determine overall receiver noise.

The signal-to-noise ratio (SNR) for an ADC can be predicted. When normalized to ADC codes, the following equation accurately predicts the SNR based on three terms. These are jitter, average DNL error and thermal noise. Each of these terms contributes to the noise within the converter.

Equation 1:

$$SNR = -20 \log \left[ \left( 2 \pi F_{ANALOG} t_J\ rms \right)^2 + \left( \frac{1 + \epsilon}{2^{12}} \right)^2 + \left( \frac{V_{NOISE\ rms}}{2^{12}} \right)^2 \right]^{1/2}$$

$F_{ANALOG}$  = analog input frequency

$t_J\ rms$  = rms jitter of the encode (rms sum of encode source and internal encode circuitry)

$\epsilon$  = average DNL of the ADC (typically 0.51 LSB)

$V_{NOISE\ rms}$  = V rms thermal noise referred to the analog input of the ADC (typically 0.707 LSB)

## Processing Gain

Processing gain is the improvement in signal-to-noise ratio (SNR) gained through oversampling and digital filtering. Most of this processing gain is accomplished using the channelizer chips. These special purpose DSP chips not only provide channel selection and filtering but also provide a data rate reduction. The required rate reduction is accomplished through a process called decimation. The term decimation rate is used to indicate the ratio of input data rate to output data rate. For example, if the input data rate is 65 MSPS and the output data rate is 1.25 MSPS, then the decimation rate is 52.

Large processing gains may be achieved in the decimation and filtering process. The purpose of the channelizer, beyond tuning, is to provide the narrowband filtering and selectivity that traditionally has been provided by the ceramic or crystal filters of a narrowband receiver. This narrowband filtering is the source of the processing gain associated with a wideband receiver and is simply the ratio of the passband to whole band expressed in dB. For example, if a 30 kHz AMPS signal is being digitized with an AD6640 sampling at 65 MSPS, the ratio would be 0.015 MHz/32.5 MHz. Expressed in log form, the processing gain is  $-10 \times \log(0.015\ MHz/32.5\ MHz)$  or 33.4 dB.

Additional filtering and noise reduction techniques can be achieved through DSP techniques; many applications do use additional process gains through proprietary noise reduction algorithms.

## Overcoming Static Nonlinearities with Dither

Typically, high resolution data converters use multistage techniques to achieve high bit resolution without large comparator arrays that would be required if traditional “flash” ADC techniques were employed. The multistage converter typically provides better wafer yields meaning lower cost and much lower power. However, since it is a multistage device, certain portions of the circuit are used repetitively as the analog input sweeps from one end of the converter range to the other. Although the worst DNL error may be less than an LSB, the repetitive nature of the transfer function can play havoc with low level dynamic signals. Spurious signals for a full-scale input may be  $-80\ dBc$ . However at 36 dB below full scale, these repetitive DNL errors may cause spurious-free dynamic range (SFDR) to fall below 80 dBFS as shown in Figure 20.

A common technique for randomizing and reducing the effects of repetitive static linearity is through the use of dither. The purpose of dither is to force the repetitive nature of static linearity to appear as if it were random. Then, the average linearity over the range of dither will dominate SFDR performance. In the AD6640, the repetitive cycle is every 15.625 mV p-p.

To ensure adequate randomization, 5.3 mV rms is required; this equates to a total dither power of  $-32.5\ dBm$ . This will randomize the DNL errors over the complete range of the residue converter. Although lower levels of dither such as that from previous analog stages will reduce some of the linearity errors, the full effect will only be gained with this larger dither. Increasing dither even more may be used to reduce some of the global INL errors. However, signals much larger than the mVs proposed here begin to reduce the usable dynamic range of the converter.

Even with the 5.3 mV rms of noise suggested, SNR would be limited to 36 dB if injected as broadband noise. To avoid this problem, noise may be injected as an out-of-band signal. Typically, this may be around dc but may just as well be at FS/2 or at some other frequency not used by the receiver. The bandwidth of the noise is several hundred kilohertz. By band-limiting and controlling its location in frequency, large levels of dither may be introduced into the receiver without seriously disrupting receiver performance. The result can be a marked improvement in the SFDR of the data converter.

Figure 23 shows the same converter shown earlier but with this injection of dither (reference Figure 20).

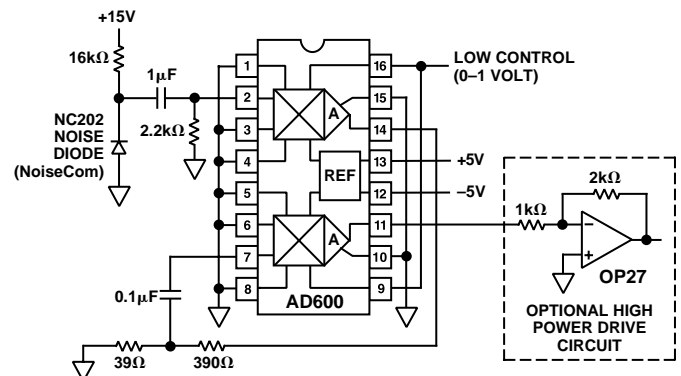

Figure 48. Noise Source (Dither Generator)

The simplest method for generating dither is through the use of a noise diode (Figure 48). In this circuit, the noise diode NC202 generates the reference noise that is gained up and driven by the AD600 and OP27 amplifier chain. The level of noise may be controlled by either presetting the control voltage when the system is set up, or by using a digital-to-analog converter (DAC) to adjust the noise level based on input signal conditions. Once generated, the signal must be introduced to the receiver strip. The easiest method is to inject the signal into the drive chain after the last down conversion as shown in Figure 49.

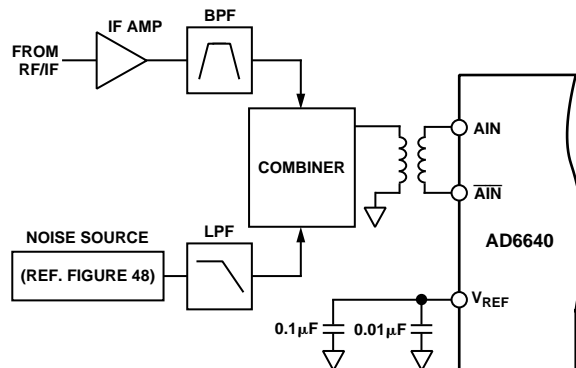

Figure 49. Using the AD6640 with Dither

### Receiver Example

To determine how the ADC performance relates to overall receiver sensitivity, the simple receiver in Figure 50 will be examined. This example assumes that the overall down conversion process can be grouped into one set of specifications, instead of individually examining all components within the system and summing them together. Although a more detailed analysis should be employed in a real design, this model will provide a good approximation.

In examining a wideband digital receiver, several considerations must be applied. Although other specifications are important, receiver sensitivity determines the absolute limits of a radio excluding the effects of other outside influences. Assuming that receiver sensitivity is limited by noise and not adjacent signal strength, several sources of noise can be identified and their overall contribution to receiver sensitivity calculated.

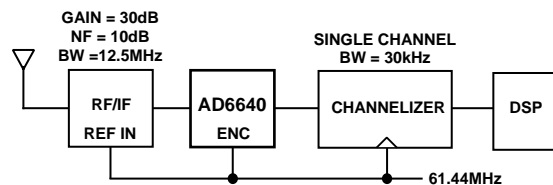

Figure 50. Receiver Analysis

The first noise calculation to make is based on the signal bandwidth at the antenna. In a typical broadband cellular receiver, the IF bandwidth is 12.5 MHz. Given that the power of noise in a given bandwidth is defined by  $P_n = kTB$ , where  $B$  is bandwidth,  $k = 1.38 \times 10^{-23}$  is Boltzman's constant and  $T = 300k$  is absolute temperature, this gives an input noise power of  $5.18 \times 10^{-14}$  watts or  $-102.86$  dBm. If our receiver front end has a gain of 30 dB and a noise figure of 10 dB, then the total noise presented to the ADC input becomes  $-62.86$  dBm ( $-102.86 + 30 + 10$ ) or 0.16 mV rms. Comparing receiver noise to dither required for good SFDR, we see that in this example, our receiver supplies about 3% of the dither required for good SFDR.

Based on a typical ADC SNR specification of 68 dB, the equivalent internal converter noise is 0.140 mV rms. Therefore total broadband noise is 0.21 mV rms. Before processing gain, this is an equivalent SNR (with respect to full scale) of 64.5 dB. Assuming a 30 kHz AMPS signal and a sample rate of 61.44 MSPS, the SNR through processing gain is increased by approximately 33 dB to 97.5 dB. However, if eight strong and equal signals are present in the ADC bandwidth, then each must be placed 18 dB below full scale to prevent ADC overdrive. Therefore we give away 18 dB of range and reduce the carrier-to-noise ratio (C/N) to 79.5 dB.

Assuming that the C/N ratio must be 10 dB or better for accurate demodulation, one of the eight signals may be reduced by 66.5 dB before demodulation becomes unreliable. At this point, the input signal power would be  $-90.5$  dBm. Referenced to the antenna, this is  $-120.5$  dBm.

To improve sensitivity, several things can be done. First, the noise figure of the receiver can be reduced. Since front end noise dominates the 0.16 mV rms, each dB reduction in noise figure translates to an additional dB of sensitivity. Second, providing broadband AGC can improve sensitivity by the range of the AGC. However, the AGC would only provide useful improvements if all in-band signals are kept to an absolute minimal power level so that AGC can be kept near the maximum gain.

This noise limited example does not adequately demonstrate the true limitations in a wideband receiver. Other limitations such as SFDR are more restrictive than SNR and noise. Assume that the analog-to-digital converter has an SFDR specification of  $-80$  dBFS or  $-76$  dBm (Full scale =  $+4$  dBm). Also assume that a tolerable carrier-to-interferer (C/I) (different from C/N) ratio is 18 dB. This means that the minimum signal level is  $-62$  dBFS ( $-80$  plus 18) or  $-58$  dBm. At the antenna, this is  $-88$  dBm. Therefore, as can be seen, SFDR (single or multi-tone) would limit receiver performance in this example. However, as shown previously, SFDR can be greatly improved through the use of dither (Figures 19, 22). In many cases, the addition of the out-of-band dither can improve receiver sensitivity nearly to that limited by thermal noise.

# AD6640

## IF Sampling, Using the AD6640 as a Mix-Down Stage

Since performance of the AD6640 extends beyond the baseband region into the third Nyquist zone, the converter has many uses as a mix-down converter in both narrowband and wideband applications. This application is called bandpass sampling. Doing this has several positive implications in terms of the selection of the IF drive amplifier. Not only is filtering a bit easier, the selection of drive amplifiers is extended to classical IF gain blocks. In the third Nyquist zone and above, the second and third harmonics are easily filtered with a bandpass filter. Now only in-band spurs that result from third order products are important.

In narrowband applications, harmonics of the ADC can be placed out-of-band. One example is the digitization of a 201 MHz IF signal using a 17.333 MHz clock. As shown in Figure 51, the spurious performance has diminished due to internal slew rate limitations of the ADC. However, the SNR of the converter is still quite good. Subsequent digital filtering with a channelizer chip such as the AD6620 will yield even better SNR.

For multicarrier applications, third order intercept of the drive amplifier is important. If the input network is matched to the internal 90 ohm input impedance, the required full-scale drive level is -3 dBm. If spurious products delivered to the ADC are required to be below -90 dBFS, the typical performance of the ADC with dither applied, then the required third order intercept point for the drive amplifier can be calculated.

For multicarrier applications, the AD6640 is useful up to about 80 MHz analog in. For single channel applications, the AD6640 is useful to 200 MHz as shown from the bandwidth charts. In either case, many common IF frequencies exist in this range of frequencies. If the ADC is used to sample these signals, they will be aliased down to baseband during the sampling process in much the same manner that a mixer will down-convert a signal. For signals in various Nyquist zones, the following equations may be used to determine the final frequency after aliasing.

$$f_{1NYQUISTS} = f_{SAMPLE} - f_{SIGNAL}$$

$$f_{2NYQUISTS} = abs(f_{SAMPLE} - f_{SIGNAL})$$

$$f_{3NYQUISTS} = 2 \times f_{SAMPLE} - f_{SIGNAL}$$

$$f_{4NYQUISTS} = abs(2 \times f_{SAMPLE} - f_{SIGNAL})$$

Using the converter to alias down these narrowband or wideband signals has many potential benefits. First and foremost is the elimination of a complete mixer stage along with amplifiers, filters and other devices, reducing cost and power dissipation. In some cases, the elimination of two IF stages is possible.

Figures 21 and 24 in Typical Performance Characteristics illustrate a multicarrier, IF Sampling System. By using dither, all spurious components are forced below 90 dBFS (Figure 24). The dashed line illustrates how a 5 MHz bandpass filter could be centered at 67.5 MHz. As discussed earlier, this approach greatly reduces the size and complexity of the receiver's RF/IF section.

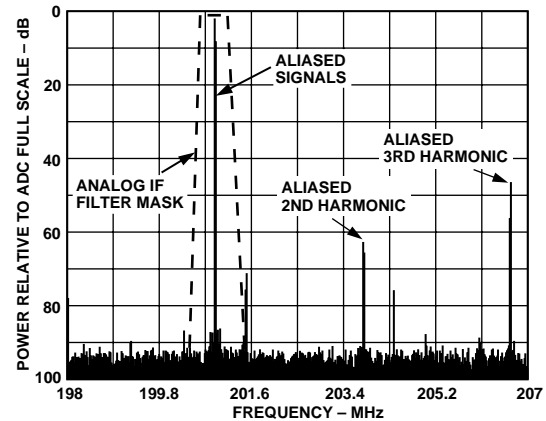

Figure 51. IF-Sampling a 201 MHz Input

## RECEIVE CHAIN FOR A PHASED ARRAY CELLULAR BASE STATION

The AD6640 is an excellent digitizer for beam forming in phased array antenna systems. The price performance of the AD6640 followed by AD6620 channelizers allows for a very competitive solution. Phase array base stations allow better coverage by focusing the receivers' sensitivity in the direction needed. Phased array systems allow for the electronic beam to form on the receive antennas.

A typical phased array system may have eight antennas as shown in Figure 52. Since a typical base station will handle 32 calls, each antenna would have to be connected to 32 receivers. If done with analog or traditional radios, the system grows quite rapidly. With a multicarrier receiver, however, the design is quite compact. Each antenna will have a wideband down-converter with one AD6640 per receiver. The output of each AD6640 would drive 32 AD6620 channelizers, which are phase locked in groups of eight—one per antenna. This allows each group of eight AD6620's to tune and lock onto a different user. When the incoming signal direction is determined, the relative phase of each AD6620 in the group can be adjusted such that the output signals sum together in a constructive manner, giving high gain and directivity in the direction of the caller. This application would not be possible with traditional receiver designs.

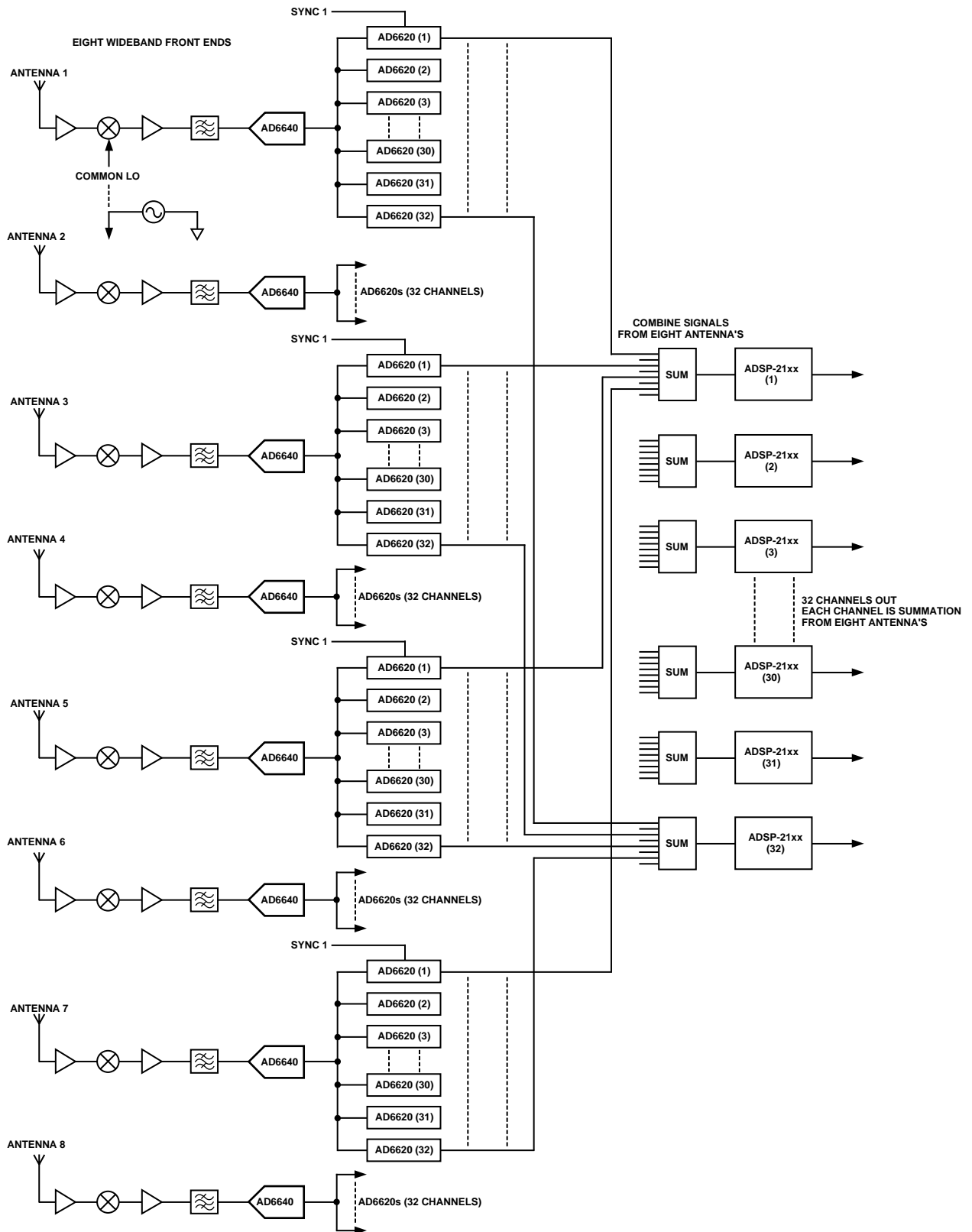
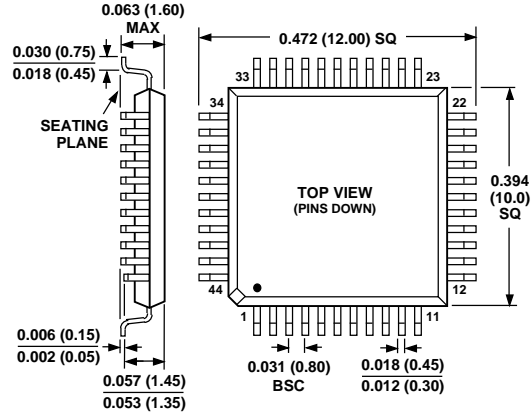

Figure 52. Receive Chain for a Phased Array Cellular Base Station with Eight Antennas and 32 Channels

**AD6640AST OUTLINE DIMENSIONS**

Dimensions shown in inches and (mm)

**44-Terminal Plastic Thin Quad Flatpack  
(ST-44)**



C3141-8-1/98

PRINTED IN U.S.A.



LittleDiode supplies new, hard to find or obsolete electronic components and semiconductors all over the world.

With over two million different components listed you are sure to find the part you need.

Feel free to visit us today at our online store:

[LittleDiode.com](http://LittleDiode.com)

Looking forward to providing you with the best possible service.