

FEATURES

- 2 complete independent BTSC encoders**
- Pilot tone generator**
- Includes subcarrier modulation**
- Typical 23 dB to 27 dB separation, 16 dB minimum**
- Signal bandwidth of 14 kHz**
- Phat-Stereo™ algorithm for stereo image enhancement**
- Dialog enhancement function for playing wide dynamic range video sources over built-in TV speakers**
- Includes L-R dual-band compressor**
- SPI® port for control of modes and effects**
- Differential output for optimum performance**
- DAC performance: 92 dB dynamic range, -92 dB THD+N**
- Output level control for setting aural carrier deviation**
- Flexible serial data port with right-justified, left-justified, I²S compatible, and DSP serial port modes**
- 48-lead LQFP plastic package**

APPLICATIONS

Digital set-top box BTSC encoder

PRODUCT OVERVIEW

The AD71028 dual digital BTSC encoder provides two complete digital BTSC encoder channels, including the pilot-tone generation and subcarrier mixing functions. Two built-in high performance DACs are provided to output the BTSC baseband composite signal. The output of the AD71028 can be connected with minimal external circuitry to the input of a 4.5 MHz aural FM modulator.

In addition to the BTSC encoders, the AD71028 also includes a stereo image enhancement function, Phat Stereo, to increase the sense of spaciousness available from closely spaced TV loudspeakers. A dialog enhancement algorithm is also included to solve the problem of playing wide dynamic range sources over limited-performance TV speakers and amplifiers. An extensive SPI port allows click-free parameter updates.

The AD71028 also includes ADI's patented multibit Σ - Δ DAC architecture. This architecture provides 92 dB SNR and THD+N of -92 dB.

FUNCTIONAL BLOCK DIAGRAM

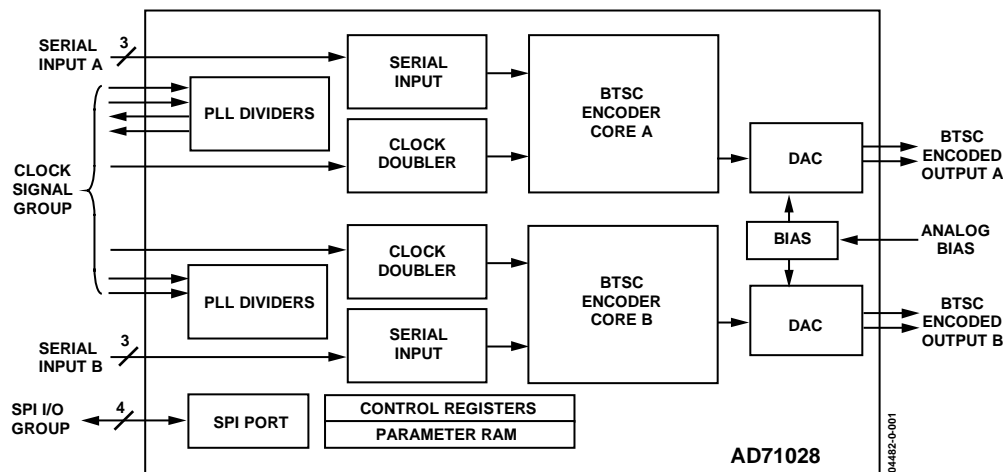

Figure 1. Functional Block Diagram

Rev. 0

Information furnished by Analog Devices is believed to be accurate and reliable. However, no responsibility is assumed by Analog Devices for its use, nor for any infringements of patents or other rights of third parties that may result from its use. Specifications subject to change without notice. No license is granted by implication or otherwise under any patent or patent rights of Analog Devices. Trademarks and registered trademarks are the property of their respective owners.

TABLE OF CONTENTS

Specifications.....	3	Input Levels.....	11
DAC Analog Performance.....	3	Clock Relationships.....	11
BTSC Encoder Performance.....	3	SPI Port.....	12
Digital I/O.....	3	Overview.....	12
Power.....	4	SPI Address Decoding.....	12
Temperature Range.....	4	Parameter RAM.....	13
Digital Timing.....	4	Control Register.....	13
Absolute Maximum Ratings.....	5	Output Level Register.....	13
Pin Configuration and Functional Descriptions.....	6	Stereo Enhancement Register.....	13
Features.....	8	Dialog Enhancement Register.....	13
Pin Functions.....	8	SPI Read/Write Data Formats.....	14
Signal Processing.....	10	Initialization.....	14
Background of BTSC.....	10	Serial Data Input Port.....	14
Performance Factors.....	10	Analog Output Section.....	16
Separation Alignment.....	10	Outline Dimensions.....	17
Phase Linearity of the External Analog Filter.....	11	Ordering Guide.....	17

REVISION HISTORY

Revision 0: Initial Version

SPECIFICATIONS

TEST CONDITIONS, UNLESS OTHERWISE NOTED

Supply Voltages (AV_{DD} , DV_{DD})	5.0 V
Ambient Temperature	25°C
Input Clock	12.288 MHz
Input Signal	1 kHz, 0 dBFS
Input Sample Rate	48 kHz
Measurement Bandwidth	20 Hz to 14 kHz
Word Width	24 Bits
Load Capacitance	50 pF
Input Voltage HI	2.4 V
Input Voltage LO	0.4 V

DAC ANALOG PERFORMANCE

Table 1.

Parameter	Min	Typ	Max	Unit
Resolution		24		Bits
Dynamic Range (20 Hz to 14 kHz, -60 dB Input) (Encoded Output, Left = Right)	85	92 ¹		dB
Total Harmonic Distortion + Noise (Encoded Output, Left = Right, 20 Hz to 14 kHz) $V_{IN} = 0$ dB	-85	-92 ¹		dB
Differential Output Range (\pm Full Scale, Left = Right)		1.7		V p-p

¹Measurement of encoded BTSC signal, not a measurement of end-to-end system.

BTSC ENCODER PERFORMANCE

Table 2.

Parameter	Min	Typ	Max	Unit
Channel Separation ¹				
30 Hz to 500 Hz	27			dB
500 Hz to 5 kHz	23			dB
5 kHz to 13.5 kHz	16			dB
Frequency Response ¹				
30 Hz to 10 kHz	+0.5		-1.0	dB
30 Hz to 13.5 kHz	+0.5		-1.5	dB

¹These specifications are measured with a -25 dB, 1 kHz input signal.

DIGITAL I/O

Table 3.

Parameter	Min	Typ	Max	Unit
Input Voltage HI (V_{IH})	2.1			V
Input Voltage LO (V_{IL})			0.8	V
Input Leakage (I_{IH} @ $V_{IH} = 2.4$ V)			10	μ A
Input Leakage (I_{IL} @ $V_{IL} = 0.8$ V)			10	μ A
High Level Output Voltage (V_{OH}) $I_{OH} = 2$ mA	$DV_{DD} - 0.5$			V
Low Level Output Voltage (V_{OL}) $I_{OL} = 2$ mA			0.4	V

AD71028

POWER

Table 4.

Parameter	Min	Typ	Max	Unit
Supplies				
Voltage, Analog and Digital	4.5	5	5.5	V
Analog Current		31	37	mA
Digital Current		97	110	mA
Dissipation				
Operation—Both Supplies		640		mW
Operation—Analog Supplies		155		mW
Operation—Digital Supplies		485		mW

TEMPERATURE RANGE

Table 5.

Parameter	Min	Typ	Max	Unit
Specifications Guaranteed		25		°C
Functionality Guaranteed	0		70	°C
Storage	-55		+125	°C

DIGITAL TIMING

Table 6.

Parameter		Min	Typ	Max	Unit
t _{DMD}	MCLK Recommended Duty Cycle @ 12.288 MHz (256 × f _s and 512 × f _s Modes)	40		60	%
t _{DBL}	BCLK Low Pulse Width	25			ns
t _{DBH}	BCLK High Pulse Width	10			ns
t _{DLS}	LRCLK Setup	0			ns
t _{DLH}	LRCLK Hold	10			ns
t _{DDS}	SDATA Setup	0			ns
t _{DDH}	SDATA Hold	10			ns
t _{CCL}	CCLK Low Pulse Width	10			ns
t _{CCH}	CCLK High Pulse Width	10			ns
t _{CLS}	CLATCH Setup	10			ns
t _{CLH}	CLATCH Hold	20			ns
t _{CLD}	CLATCH High Pulse Width	10			ns
t _{CDS}	CDATA Setup	0			ns
t _{CDH}	CDATA Hold	10			ns
t _{RLP}	Reset LO Pulse Width	10			ns

ABSOLUTE MAXIMUM RATINGS

Table 7. AD71028 Stress Ratings

Parameter	Min	Max	Unit
DV _{DD} to DGND	-0.3	+6	V
ODV _{DD} to DGND	-0.3	+6	V
AVDD to AGND	-0.3	+6	V
Digital Inputs	DGND - 0.3	DV _{DD} + 0.3	V
Analog Inputs	AGND - 0.3	AV _{DD} + 0.3	V
AGND to DGND	-0.3	+0.3	V
Reference Voltage		(AV _{DD} + 0.3)/2	V
Maximum Junction Temperature		125	°C
Storage Temperature Range	-65	+150	°C
Soldering		300	°C
		10	sec

Table 8. Package Characteristics (48-Lead LQFP)

Parameter	Min	Typ	Max	Unit
θ _{JA} Thermal Resistance [Junction-to-Ambient]		72		°C/W
θ _{JC} Thermal Resistance [Junction-to-Case]		19.5		°C/W

Stresses above those listed under Absolute Maximum Ratings may cause permanent damage to the device. This is a stress rating only; functional operation of the device at these or any other conditions above those listed in the operational sections of this specification is not implied. Exposure to absolute maximum rating conditions for extended periods may affect device reliability.

ESD CAUTION

ESD (electrostatic discharge) sensitive device. Electrostatic charges as high as 4000 V readily accumulate on the human body and test equipment and can discharge without detection. Although this product features proprietary ESD protection circuitry, permanent damage may occur on devices subjected to high energy electrostatic discharges. Therefore, proper ESD precautions are recommended to avoid performance degradation or loss of functionality.



PIN CONFIGURATION AND FUNCTIONAL DESCRIPTIONS

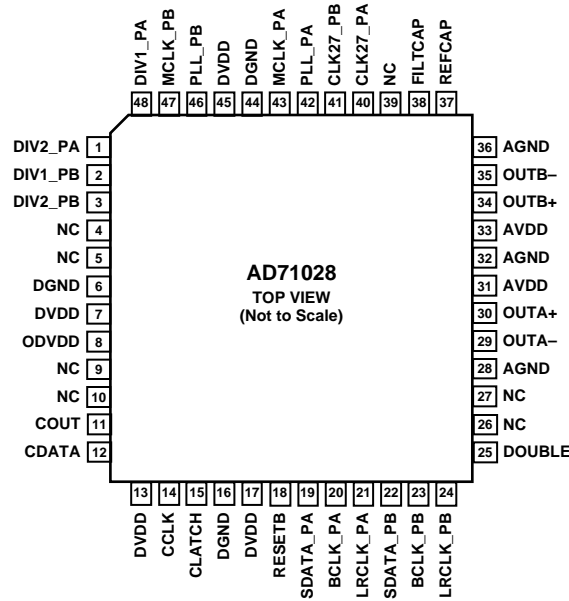

NC = NO CONNECT

Figure 2. 48-Lead Low Profile Quad Flat Pack (LQFP)

Table 9. Pin Function Descriptions

Pin No.	Mnemonic	Input/Output	Description
1	DIV2_PA	OUT	CLK27_PA clock (Pin 40) Divided by 1125
2	DIV1_PB	OUT	PLL_PB Clock (Pin 46) Divided by 512 (DOUBLE = 1) or 1024 (DOUBLE = 0)
3	DIV2_PB	OUT	CLK27_PB Clock (Pin 41) Divided by 1125
4, 5, 9, 10, 26, 27, 39	NC		No Connection
6, 16, 44	DGND		Digital Ground
7, 13, 17, 45	DVDD		Digital Supply for DSP Core
8	ODVDD		Digital Supply for Output Buffers
11	COUT	OUT	SPI Readback
12	CDATA	IN	SPI Control Data Input
14	CCLK	IN	SPI Serial Bit Clock
15	CLATCH	IN	SPI Control Latch Signal
18	RESETB	IN	Reset Signal for Both Processors, Active Low
19	SDATA_PA	IN	Data Input to Processor A
20	BCLK_PA	IN	Bit Clock Signal for Serial Data Input to Processor A
21	LRCLK_PA	IN	Left/Right Framing Signal for Data Input to Processor A
22	SDATA_PB	IN	Data Input to Processor B
23	BCLK_PB	IN	Bit Clock Signal for Serial Data Input to Processor B
24	LRCLK_PB	IN	Left/Right Framing Signal for Data Input to Processor B
25	DOUBLE	IN	Enables Internal Clock Doubler for 12.288 MHz Input (Both Processors)
28, 32, 36	AGND		Analog Ground
29	OUTA-	OUT	Negative Analog Output, Processor A
30	OUTA+	OUT	Positive Analog Output, Processor A
31, 33	AVDD		Analog Supply
34	OUTB+	OUT	Positive Analog Output, Processor B
35	OUTB-	OUT	Negative Analog Output, Processor B
37	REFCAP	IN	Connection Point for 10 μ F VREF Filter Capacitor
38	FILTCAP	IN	Connection for Noise Reduction Capacitor

Pin No.	Mnemonic	Input/Output	Description
40	CLK27_PA	IN	Input for 27 MHz Video Reference Clock, Processor A
41	CLK27_PB	IN	Input for 27 MHz Video Reference Clock, Processor B
42	PLL_PA	IN	Input from External PLL, Processor A
43	MCLK_PA	IN	Clock Input to Processor A
46	PLL_PB	IN	Input from External PLL, Processor B
47	MCLK_PB	IN	Clock Input to Processor B
48	DIV1_PA	OUT	PLL_PA Clock (Pin 42) Divided by 512 (DOUBLE = 1) or 1024 (DOUBLE = 0)

FEATURES

The AD71028 is comprised of two independent digital-input BTSC encoders. The two processors allow two completely asynchronous BTSC channels to be encoded, each with its own clock signals. Figure 1 shows the block diagram of the device.

Signal processing parameters are stored in a 256-location parameter RAM, which is initialized on power-up by an internal boot ROM. The values stored in the parameter RAM control all the filter coefficients, mixing, and dynamics processing code used in the BTSC algorithm.

The AD71028 has an SPI port that supports complete read/write capability of the parameter RAM, as well as a control port and several other registers that allow the various signal processing parameters to be controlled. The AD71028 can run as a standalone processor without SPI control.

The AD71028 has a very flexible serial data input port that allows for glueless interconnection to a variety of signal sources. The AD71028 can be configured in left-justified, I²S, right-justified, or DSP serial port compatible modes. It can support 16, 20, and 24 bits in all modes. The AD71028 accepts serial audio data in MSB first, twos complement format.

The AD71028 operates from a single 5 V power supply. It is fabricated on a single monolithic integrated circuit and is housed in a 48-lead LQFP package for operation over the 0°C to 70°C temperature range.

PIN FUNCTIONS

Pin names and functions are shown below. Note that pins with a “_PA” designation are connected to Processor A, while those with a “_PB” designation are connected to Processor B. All input pins have a logic threshold compatible with TTL input levels, and may therefore be used in systems with 3.3 V logic. All digital output levels are controlled by the ODVDD pin, which may range from 2.7 V to 5.5 V, for compatibility with a wide range of external devices.

LRCLK_PA, LRCLK_PB

Left/right clocks for framing the input data. The interpretation of the LRCLK changes according to the serial mode, set by writing to the control registers.

BCLK_PA, BCLK_PB

Serial bit clocks for clocking in the serial data. The interpretation of BCLK changes according to the serial mode, which is set by writing to the control registers.

SDATA_PA, SDATA_PB

Serial data inputs to each processor. The serial format is selected by writing to Bits <3:0> of the control registers.

MCLK_PA, MCLK_PB

Master clock inputs. The master clock frequency must be either $256 \times f_s$ or $512 \times f_s$, where f_s is the input sampling frequency. If the DOUBLE pin is high, an internal clock doubler is used to take a $256 \times f_s$ input clock and produce the $512 \times f_s$ internal clock required by the DSP core. If the DOUBLE pin is low, the frequency of the input clock must be set to $512 \times f_s$. In case these clock signals are not available, a simple external PLL may be used to generate the master clock signals. On-chip dividers are provided to simplify this task.

CDATA

Serial data in for the SPI control port. See the SPI Port section for more information on SPI port timing.

COU

Serial data output. This is used for reading back registers and memory locations. It is three-stated when an SPI read is not active. See the SPI Port section for more information on SPI port timing.

CCLK

SPI bit-rate clock. This pin may either run continuously or be gated in between SPI transactions. See the SPI Port section for more information on SPI port timing.

CLATCH

SPI latch signal. This signal must go low at the beginning of an SPI transaction and high at the end of a transaction. Each SPI transaction may take a different number of CCLKs to complete, depending on the address and read/write bit that are sent at the beginning of the SPI transaction. Detailed SPI timing information can be found in the SPI Port section.

RESETB

Active-low reset signal. After RESETB transitions from low to high, the AD71028 goes through an initialization sequence where the parameter RAMs are initialized with the contents of the on-board boot ROM. All SPI registers are set to 0, and the data RAMs are also zeroed. The initialization is complete after 1024 MCLK cycles. New values should not be written to the SPI port until the initialization is complete.

DOUBLE

When this pin is set high, the internal clock doubler is turned on so a $256 \times f_s$ MCLK can be input to the AD71028.

PLL_PA, PLL_PB

PLL clock input pins for Processor A and Processor B. These pins are connected to an internal divide-by-1024 circuit (or divide-by-512 if DOUBLE is high). This makes it possible to use an inexpensive external PLL to generate the system clock. If an external PLL is used, this pin should also be connected to the appropriate MCLK_PA or MCLK_PB pin.

CLK27_PA, CLK27_PB

Input pins to the divide-by-1125 block. If an external PLL is used to generate the audio master clock, the 27 MHz video master clock may be applied to these pins where it is divided by 1125 to produce a 24 kHz feedback clock to the external PLL phase detector.

DIV1_PA, DIV1_PB

Output of divide-by-1024 circuit. Divides the master clock signal by 1024 (or 512 when DOUBLE is asserted). Used to interface to external PLL.

DIV2_PA, DIV2_PB

Output of divide-by-1125 circuit. Divides the master-clock signal by 1125. Used to interface to external PLL. The output signal is a pulse with a duration of one master clock, and should therefore be used with edge-triggered phase detectors.

REFCAP

Analog reference voltage input. The nominal REFCAP input voltage is 2.5 V; the analog gain scales directly with the voltage on this pin. Any ac signal on this pin will cause distortion, and therefore a large decoupling capacitor should be used to ensure that the voltage on REFCAP is clean. The input impedance of REFCAP is greater than 1 M Ω .

FILTCAP

Filter cap point. This pin is used to reduce the noise on an internal biasing point in order to provide the highest performance. It may not be necessary to connect this pin, depending on the quality of the layout and grounding used in the application circuit.

DVDD

Digital V_{DD} for core. 5 V nominal.

ODVDD

Digital V_{DD} for all digital outputs. Variable from 2.7 V to 5.5 V.

DGND

Digital ground.

AVDD

Analog V_{DD}. 5 V nominal. Bypass capacitors should be placed close to the pins and connected directly to the analog ground plane.

AGND

Analog ground.

OUTA+, OUTA-

Differential analog outputs for Processor A. The nominal output voltage for a 1 kHz 0 dB mono input signal is 600 mV rms. This level may be adjusted by writing to SPI location 258.

OUTB+, OUTB-

Differential analog outputs for Processor B. The nominal output voltage for a 1 kHz 0 dB mono input signal is 600 mV rms. This level may be adjusted by writing to SPI location 770.

SIGNAL PROCESSING

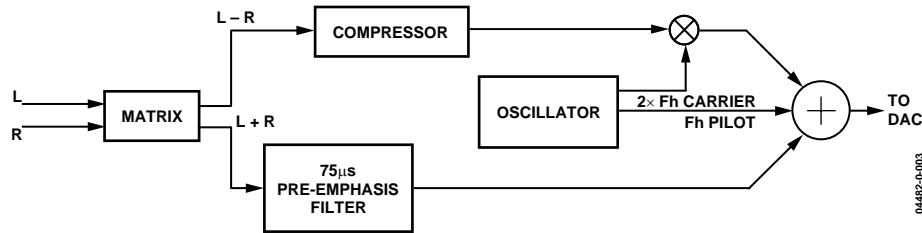

Figure 3. Signal Processing Flow

BACKGROUND OF BTSC

BTSC is the name of the standard for adding stereo audio capability to the US television system. It is in many ways similar to the algorithm used for FM stereo broadcasts, with the addition of a sophisticated compressor circuit to improve the signal-to-noise ratio.

The processing of mono ($L = R$) signals is unchanged from the original pre-BTSC system in order to maintain compatibility with non-BTSC TV receivers. The $L + R$ signal is applied to a $75 \mu\text{s}$ pre-emphasis filter, and is then applied to a 4.5 MHz FM modulator, which is later added into the video signal to create a composite video signal.

Stereo capability is added by taking the $L - R$ signal, applying it to a 2-band dynamic compressor, and then multiplying this signal by a carrier signal at twice the horizontal scanning rate (F_h), or about $2 \times 15.734 \text{ kHz}$. This multiplication is known as double-sideband suppressed-carrier modulation, and it effectively translates the compressed $L - R$ spectrum up in frequency so that it sits above the audio band (Figure 3).

In order for the receiver to recover this $L - R$ signal, a pilot tone at the horizontal rate is added to the signal. The receiver has a PLL that locks to this pilot and generates a signal at the carrier frequency. This signal is then used to multiply the composite BTSC-encoded signal, which translates this component back down to baseband. The $L - R$ signal is then applied to a 2-band expander, which is the complement to the earlier compressor step. Once the $L + R$ and $L - R$ signals are recovered, a simple addition/subtraction circuit (sometimes referred to as the “matrix”) can be used to recover the L and R signal.

Since the pilot tone is added at 15.734 kHz, it is necessary to reduce the signal’s bandwidth so that audio signals cannot interfere with the pilot tone. In the AD71028, the bandwidth is limited to 14 kHz; above this frequency, the response decays very rapidly.

PERFORMANCE FACTORS

In order to maintain good separation between left and right, it is necessary to closely match the filtering and companding standards set forth in the standard (FCC OET60). Even small errors can result in poor performance. The AD71028 has been programmed to match these standards as accurately as possible. Separation typically ranges from 30 dB at frequencies below 1 kHz to 15 dB at 14 kHz. Measuring these numbers can be difficult as significant differences exist between many so-called reference decoders, which are all implemented with analog components.

SEPARATION ALIGNMENT

The BTSC encoder outputs are all specified in terms of the deviation of the FM 4.5 MHz carrier. For the AD71028, a digital input level of 0 dB (mono signal) should cause a carrier deviation of $\pm 25 \text{ kHz}$ without the $75 \mu\text{s}$ pre-emphasis filter. In practice, the pre-emphasis filter may be left in for this adjustment, as long as the frequency is low enough to not be affected by the pre-emphasis filter. It is critical to maintain the proper gain relationship between the BTSC encoder and the 4.5 MHz FM modulator. A common mistake is to assume that changing the gain between the BTSC encoder output and the FM modulator input has the same effect as changing the audio input level going in to the BTSC encoder. The presence of a complicated 2-band nonlinear dynamics processor means that the encoder output must be connected to the decoder input (through the FM modulation/demodulation process) with a known gain. If this gain is changed, the separation will significantly suffer.

When measuring the AD71028 on the bench, it is possible to use a BTSC reference decoder box, so that the FM modulation/demodulation process may be skipped. These units have a method of adjusting the input voltage sensitivity to achieve best separation. The output level of the AD71028 can also be adjusted over a wide range using either the SPI control port or by adjusting the values of the components used in the external analog low-pass filter that is between the BTSC encoder output and the input to the FM modulator.

PHASE LINEARITY OF THE EXTERNAL ANALOG FILTER

If the time alignment of the pilot to the carrier signal is not close to 0 degrees, a loss of separation can occur. This means that the external analog low-pass filter should be a linear-phase design to provide constant group delay over the range from dc to 50 kHz. Bessel filters are recommended for this application. Figure 12 shows a recommended design for these filters.

INPUT LEVELS

The maximum input level to the AD71028 changes across frequency. Table 10 shows the maximum allowable input level for different frequencies. These values are part of the BTSC specification and are not a function of this chip.

Table 10. Maximum Input Levels to the BTSC Encoder across Frequency

Frequency (Hz)	Maximum Input Level (dBFS)
20 to 1000	0 dB
1600	-1 dB
2500	-3 dB
3150	-5 dB
5000	-8 dB
8000	-11 dB
12500	-15 dB

CLOCK RELATIONSHIPS

In an MPEG receiver architecture, all clocks are typically generated from a 27 MHz master clock. The following integer relationships are found between the clocks, with $F_h = 15.734$ kHz:

- a) $27 \text{ MHz}/F_h = 1716 = 2 \times 2 \times 3 \times 11 \times 13$
- b) $F_h/2 = F_{\text{color_subcarrier}}/(5 \times 7 \times 13)$
- c) $27 \text{ MHz}/F_{\text{color_subcarrier}} = (5 \times 7)/(2 \times 2 \times 2 \times 3 \times 11)$
- d) $27 \text{ MHz}/48 \text{ kHz} = 1125/2$

The AD71028 contains a clock doubler circuit that may be used to generate an internal $512 \times f_s$ clock when the external clock is $256 \times f_s$. The clock mode is set by connecting the DOUBLE pin either high or low. This pin should be tied either high or low and should not be changed after power-up.

The AD71028 requires a master clock at either 256×48 kHz (12.288 MHz) when $\text{DOUBLE} = 1$ or 512×48 kHz (24.576 MHz) when $\text{DOUBLE} = 0$. In some cases, this signal is provided by the MPEG decoder chip itself. In other cases, only the 27 MHz video clock may be available. In this case, the AD71028 provides on-chip dividers to interface to an external PLL such as the 74HC4046. Figure 4 shows the circuit to accomplish this. The 27 MHz clock is applied to the AD71028 and divided down by 1125, producing a signal at 24 kHz. The PLL oscillator output is divided down by 512, producing a 24 kHz output (when locked). These two signals are applied to the phase-comparator inputs of the external PLL. Note that the divided-down 27 MHz signal looks like a pulse with a duration of one master clock, and therefore only edge-triggered phase detectors should be used.

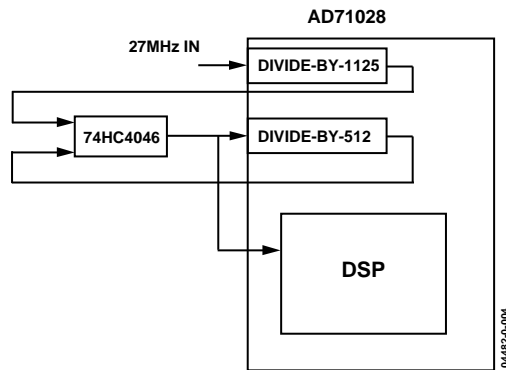

Figure 4. PLL Connections for 27 MHz Master Clock

SPI PORT

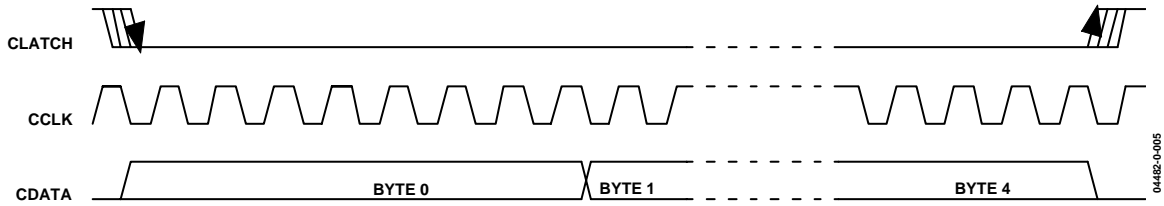

Figure 5. Sample of SPI Write Format (Single-Write Mode)

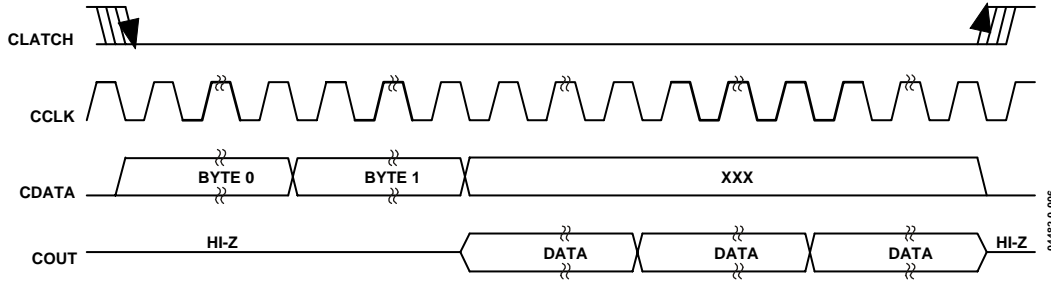

Figure 6. Sample of SPI Read Format (Single-Read Mode)

OVERVIEW

The AD71028 can be controlled using the SPI port. In general, there are three parameters per processor that can be controlled: the encoder output level, the Phat Stereo image enhancement algorithm, and the dialog enhancement algorithm. It is also possible to write new data into the parameter RAM to alter the filter coefficients used in the BTSC encoding process. This is a fairly complex topic unnecessary for normal operation of the chip, and the details are not included in this data sheet. Please contact ADI if modifications to the BTSC filters are required.

The SPI port uses a 4-wire interface consisting of CLATCH, CCLK, CDATA, and COUT signals. The CLATCH signal goes low at the beginning of a transaction and high at the end of a transaction. The CCLK signal latches the serial input data on a low-to-high transition. The CDATA signal carries the serial input data, and the COUT signal is the serial output data. The

COUT signal remains three-stated until a READ operation is requested. This allows other SPI compatible peripherals to share the same readback line. All SPI transactions follow the same basic format, shown in Figure 5. Figure 6 shows the read format.

The Wb/R bit is low for a write and high for a read operation. The 10-bit address word is decoded into either a location in the parameter RAM or one of the SPI registers. The number of data bytes varies according to the register or memory being accessed. The detailed data format diagram for continuous-mode operation is given in the SPI Read/Write Data Formats section.

SPI ADDRESS DECODING

Table 11 shows the address decoding used in the SPI port. The SPI address space encompasses a set of registers and the parameter RAM. The parameter RAM is loaded on power-up from an on-board boot ROM.

Table 11. SPI Port Address Decoding

SPI Address	Register Name	Read/Write Word Length
0–255	Parameter RAM Processor A	Write: 22 Bits, Read: 22 Bits
256	SPI Control Register Processor A	Write: 11 Bits, Read: N/A
257	Reserved	
258	Output Level Processor A	Write: 22 Bits, Read: N/A
259	Stereo Spreading Control Processor A	Write: 22 Bits, Read: N/A
260	Dialog Enhancement Control Processor A	Write: 22 Bits, Read: N/A
512–767	Parameter RAM Processor B	Write: 22 Bits, Read: 22 Bits
768	SPI Control Register Processor B	Write: 22 Bits, Read: N/A
769	Reserved	
770	Output Level Processor B	Write: 22 Bits, Read: N/A
771	Stereo Spreading Control Processor B	Write: 22 Bits, Read: N/A
772	Dialog Enhancement Control Processor B	Write: 22 Bits, Read: N/A

PARAMETER RAM

The parameters for the two BTSC processors are stored in two 256-location RAM spaces. The user should not change most of these parameters, although editing the dynamics processing curve for dialog enhancement may be useful if the curve needs to be changed for a specific application. This is explained in the Dialog Enhancement Register section of this data sheet.

CONTROL REGISTER

Control Register 1 is an 11-bit register that controls serial modes, de-emphasis, mute, power-down, and SPI-to-memory transfers. Table 12 documents the contents of this register.

Bits 4:5 and 8:10 are reserved and should be set to 0 at all times. The audio signal is muted with Bit 7 of the control register.

The soft power-down bit (Bit 6) stops the internal clocks to the DSP core, but does not reset the part. The digital power consumption is reduced to a low level when this bit is asserted. Reset can only be asserted using the external reset pin.

Bits 3:2 select the serial format from one of four modes. These different formats are discussed in the Initialization section of this data sheet.

The word length bits (1:0) are used in right-justified serial modes to determine where the MSB is located relative to the start of the audio frame.

Table 12. Control Register Contents

Register Bits	Function
10	Reserved, Set to 0
9	Reserved, Set to 0
8	Reserved, Set to 0
7	Soft Mute (1 = Start Mute Sequence)
6	Soft Power-Down (1 = Power-Down)
5:4	Reserved, Set to 00
3:2	Serial In Mode 00 = I ² S 01 = Right-Justified 10 = DSP 11 = Left-Justified
1:0	Word Length 00 = 24 Bits 01 = 20 Bits 10 = 16 Bits 11 = 16 Bits

OUTPUT LEVEL REGISTER

The output level register controls the overall BTSC output level. Its default value is -6 dB, which outputs a 600 mV rms reference level for a 1 kHz 0 dB mono digital input signal. This value is in 2.20 format, and -6 dB corresponds to binary 00100000000000000000. This register is used in conjunction with the output filter to match the output BTSC level of the encoder with the decoder input to achieve maximum separation values. This level control should not be used to control the overall volume level of the audio signal.

STEREO ENHANCEMENT REGISTER

This register controls ADI's patented Phat Stereo spatial enhancement algorithm. The default is all 0s, which corresponds to no effect. The maximum setting is 01000000000000000000, or a twos complement fractional value of 1.0. Note that the bass energy in each channel is increased using this algorithm, which may cause some digital clipping on full-scale signal peaks, especially at low frequencies.

DIALOG ENHANCEMENT REGISTER

This controls the built-in dialog-enhancement algorithm, and defaults to 0. The maximum setting is 01000000000000000000, or a twos complement fractional value of 1.0. This algorithm is intended to solve the problem of playing back high dynamic range digital audio signals over a television's built-in speakers. It provides an amplitude boost to signals that are in the range where dialog signals are usually found, while at the same time preventing loud special effects passages from overloading the speakers or amplifiers.

The dialog enhancement control is set up as a dynamics processing curve with 33 locations on the curve, each spaced 3 dB apart. There is a default dialog enhancement curve that is set at power-up, but this can be changed if a different curve is desired. The curve ranges from an rms input level of -87 dB on the low end to $+9$ dB on the high end. The value corresponding to each point in the parameter RAM represents a gain at the appropriate input level. This gain value should range from 0 ($-\infty$ dB) to $+2.0 - 1$ LSB (approximately $+6$ dB). The gain at a -87 dB input corresponds to parameter RAM location 4 on Processor A and location 516 on Processor B. The table extends to the $+9$ dB input gain at locations 36 and 548 for Processors A and B, respectively.

AD71028

Table 13. SPI Control Register 1 Write format

Byte 0	Byte 1	Byte 2	Byte 3
00000, Wb/R, Adr [9:8]	Adr [7:0]	00000, Bit [10:8]	Bit [7:0]

Table 14. SPI Write Format for Parameter RAM, Output Level, Stereo Spreading and Dialog Enhancement Registers

Byte 0	Byte1	Byte 2	Byte 3	Byte 4
000000, Adr [9:8]	Adr [7:0]	00, Level [21:16]	Level [15:8]	Level [7:0]

SPI READ/WRITE DATA FORMATS

The read/write formats of the SPI port are designed to be byte-oriented. This allows for easy programming of common microcontroller chips. In order to fit into a byte-oriented format, 0s are appended to the data fields in order to extend the data-word to the next multiple of 8 bits. For example, 22-bit words written to the SPI parameter RAM are appended with two leading zeros in order to reach 24 bits (3 bytes). These zero-extended data fields are appended to a 2-byte field consisting of a read/write bit and a 10-bit address. The SPI port knows how many data bytes to expect based on the address that is received in the first 2 bytes.

INITIALIZATION

Power-Up Sequence

The AD71028 has a built-in power-up sequence that initializes the contents of all internal RAM. During this time, the SPI parameter RAM is filled with values from its associated boot ROM. The data memories are also cleared during this time.

The boot sequence lasts for 1024 MCLK cycles and starts on the rising edge of the RESETB pin. The user should avoid writing to or reading from the SPI registers during this period of time.

SERIAL DATA INPUT PORT

The AD71028's flexible serial data input port accepts data in two's complement, MSB-first format. The left channel data field always precedes the right channel data field. The serial mode is set by using mode select bits in the SPI control register. In all modes except the right-justified mode, the serial port will accept an arbitrary number of bits up to a limit of 24 (extra bits will not cause an error, but they will be truncated internally). In right-justified mode, SPI control register bits are used to set the word length to 16, 20, or 24 bits. The default on power-up is 24-bit mode. Proper operation of the right-justified mode requires that there be exactly 64 BCLKs per audio frame.

Serial Data Input Modes

Figure 7 shows the left-justified mode. LRCLK is high for the left channel and low for the right channel. Data is sampled on the rising edge of BCLK. The MSB is left-justified to a LRCLK transition with no MSB delay. The left-justified mode can accept any word length up to 24 bits.

Figure 8 shows the I²S mode, which is the default setting. LRCLK is low for the left channel, and the MSB is delayed from the edge of the LRCLK by a single BCLK period. The I²S mode can be used to accept any number of bits up to 24.

Figure 9 shows the AD71028's right-justified mode. LRCLK is high for the left channel and low for the right channel. Data is sampled on the rising edge of BCLK. The start of data is delayed from the LRCLK edge by 16, 12, or 8 BCLK intervals, depending on the selected word length. The default word length is 24 bits; other word lengths are set by writing to Bits <1:0> of the control register. In right-justified mode, it is assumed that there are 64 BCLKs per frame.

Figure 10 shows the DSP serial port mode. LRCLK must pulse high for at least one bit clock period before the MSB of the left channel is valid, and LRCLK must pulse high again for at least one bit clock period before the MSB of the right channel is valid. Data is sampled on the falling edge of BCLK. The DSP serial port mode can be used with any word length up to 24 bits. In this mode, it is the responsibility of the DSP to ensure that the left data is transmitted with the first LRCLK pulse, and that synchronism is maintained from that point forward.

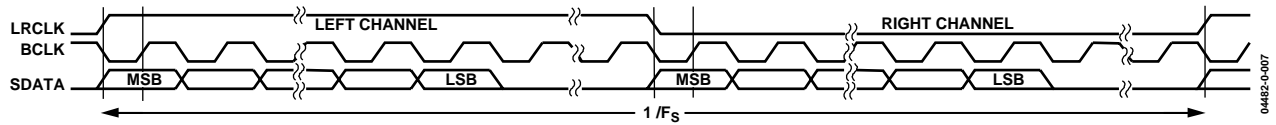

Figure 7. Left-Justified Mode—16 Bits to 24 Bits per Channel

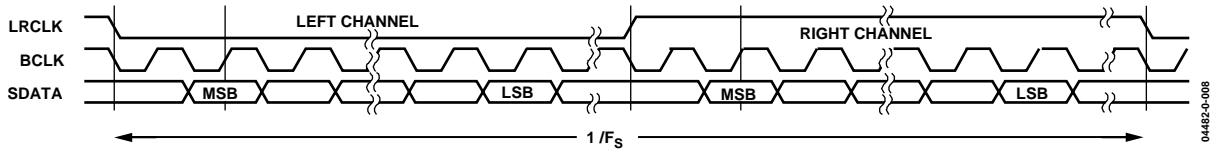

Figure 8. I²S Mode—16 Bits to 24 Bits per Channel

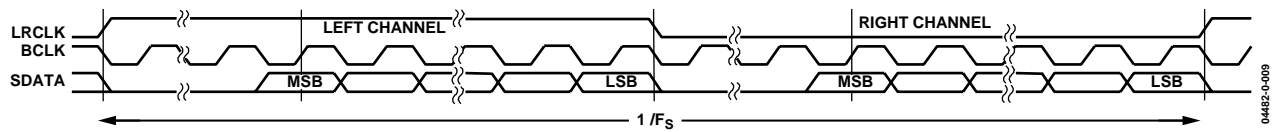

Figure 9. Right-Justified Mode—16 Bits to 24 Bits per Channel

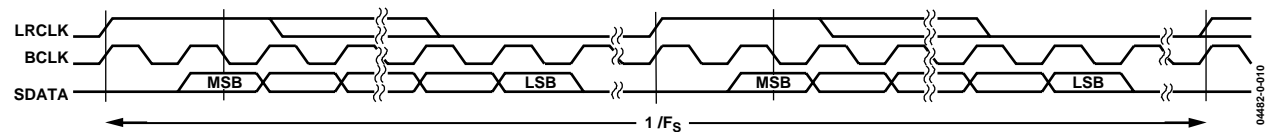

Figure 10. DSP Mode—16 Bits to 24 Bits per Channel

NOTES

1. DSP mode does not identify the channel.
2. LRCLK normally operates at F_s ; in DSP mode, LRCLK operates at $2 \times F_s$.
3. BCLK frequency is normally $64 \times$ LRCLK but may be operated in burst mode.

ANALOG OUTPUT SECTION

Figure 11 shows the block diagram of the analog output section (one of two channels). A series of current sources is controlled by a digital Σ - Δ modulator. Depending on the digital code from the modulator, each current source is connected to the summing junction of either a positive I-to-V converter or a negative I-to-V converter. Two extra current sources that push instead of pull are added to set the midscale common-mode voltage.

All current sources are derived from the VREF input pin. The gain of the AD71028 is directly proportional to the magnitude of the current sources, and therefore the gain of the AD71028 is proportional to the voltage on the VREF pin. The nominal VREF voltage should be set to 2.5 V, using a simple resistive divider from the analog supply. The VREF and biasing circuits are common to both DACs.

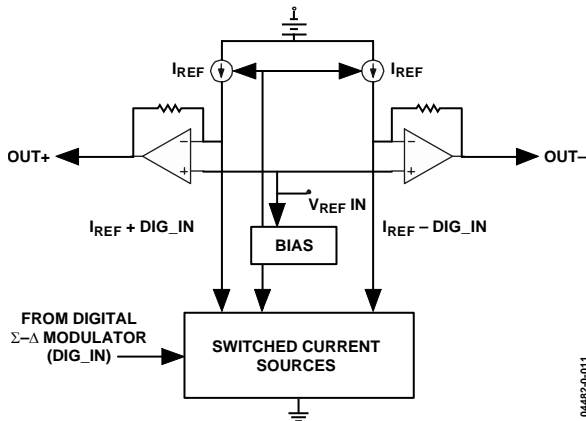

Figure 11. Internal DAC Analog Architecture

04482-0-011

Since the VREF input effectively multiplies the signal, care must be taken to ensure that no ac signals appear on this pin. This can be accomplished by using a large decoupling capacitor in the VREF external resistive divider circuit. If the VREF signal is derived by dividing the 5 V analog supply, the time constant of the divider must effectively filter any noise on the supply. If the VREF signal is derived from an unregulated power amplifier supply, the time constant must be longer because the ripple on the amplifier supply voltage will presumably be greater than in the case of the 5 V supply.

The AD71028 should be used with an external third-order filter on each output channel. The circuit shown in Figure 12 combines a third-order filter and a single-ended-to-differential converter in the same circuit. The values shown are for a 100 kHz Bessel filter. The use of a Bessel filter is important to maintain the time alignment of the pilot to the carrier. If these signals are not in phase, a loss of separation will occur.

The outputs can also be used single-ended, with some loss of performance; the DAC distortion may become significantly poorer, although the SNR will remain quite high.

For best performance, a large (>10 μ F) capacitor should be connected between the FILTCAP pin and analog ground.

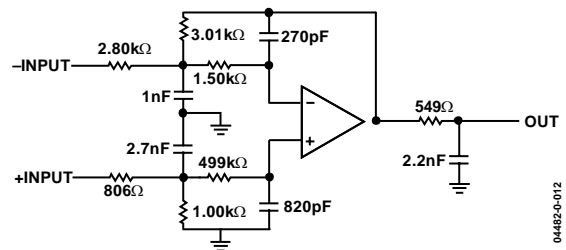

Figure 12. Recommended External Analog Filter for Each Channel

04482-0-012

OUTLINE DIMENSIONS

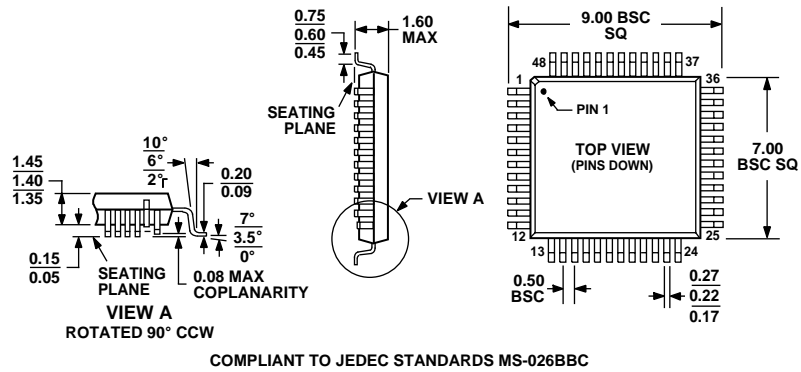

Figure 13. 48-Lead Low Profile Quad Flatpack [LQFP]
(ST-48)
Dimensions Shown in Millimeters

ORDERING GUIDE

Model	Temperature Range	Package Description	Package Option
AD71028JST	-0°C to +70°C	48-Lead LQFP	ST-48
AD71028JSTRL	-0°C to +70°C	48-Lead LQFP	ST-48 on 13" Reel

AD71028

NOTES

NOTES

AD71028

NOTES



LittleDiode supplies new, hard to find or obsolete electronic components and semiconductors all over the world.

With over two million different components listed you are sure to find the part you need.

Feel free to visit us today at our online store:

LittleDiode.com

Looking forward to providing you with the best possible service.