

August 1995

## Features

- 1.2 Micron Radiation Hardened SOS CMOS
  - Total Dose  $3 \times 10^5$  RAD (Si)
  - Transient Upset  $>1 \times 10^{11}$  RAD (Si)/s
  - Single Event Upset  $< 1 \times 10^{-12}$  Errors/Bit-Day
- Latch-up Free
- LET Threshold  $>250$  MEV/mg/cm<sup>2</sup>
- Low Standby Supply Current 10mA (Max)
- Low Operating Supply Current 100mA (2MHz)
- Fast Access Time 50ns (Max), 35ns (Typ)
- High Output Drive Capability
- Gated Input Buffers (Gated by E2)
- Six Transistor Memory Cell
- Fully Static Design
- Asynchronous Operation
- CMOS Inputs
- 5V Single Power Supply
- Military Temperature Range -55°C to +125°C
- Industry Standard JEDEC Pinout

## Description

The Intersil HS-65647RH is a fully asynchronous 8K x 8 radiation hardened static RAM. This RAM is fabricated using the Intersil 1.2 micron silicon-on-sapphire CMOS technology. This technology gives exceptional hardness to all types of radiation, including neutron fluence, total ionizing dose, high intensity ionizing dose rates, and cosmic rays.

Low power operation is provided by a fully static design. Low standby power can be achieved without pull-up resistors, due to the gated input buffer design.

## Functional Diagram

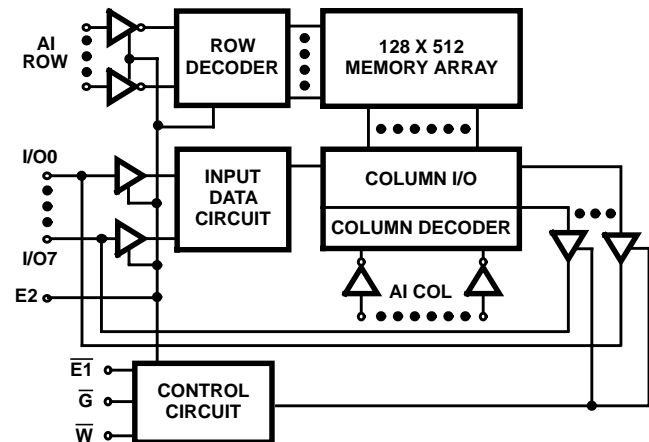

TRUTH TABLE

E1	E2	G-bar	W-bar	MODE
X	0	X	X	Low Power Standby
1	1	X	X	Disabled
0	1	1	1	Enabled
0	1	0	1	Read
0	1	X	0	Write

## Ordering Information

PART NUMBER	TEMPERATURE RANGE	PACKAGE
HS1-65647RH-Q	-55°C to +125°C	28 Lead SBDIP
HS1-65647RH-8	-55°C to +125°C	28 Lead SBDIP
HS1-65647RH/Proto	-55°C to +125°C	28 Lead SBDIP
HS1-65647RH/Sample	+25°C	28 Lead SBDIP
HS9-65647RH-Q	-55°C to +125°C	28 Lead Ceramic Flatpack
HS9-65647RH-8	-55°C to +125°C	28 Lead Ceramic Flatpack
HS9-65647RH/Proto	-55°C to +125°C	28 Lead Ceramic Flatpack
HS9-65647RH/Sample	+25°C	28 Lead Ceramic Flatpack
HS9A-65647RH-Q	-55°C to +125°C	36 Lead Ceramic Flatpack

# HS-65647RH

## Pinouts

**HS1-65647RH 28 LEAD CERAMIC DUAL-IN-LINE  
METAL SEAL PACKAGE (SBDIP)  
MIL-STD-1835 CDIP2-T28  
TOP VIEW**

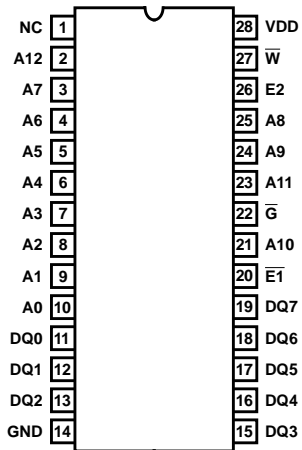

**HS9-65647RH 28 LEAD CERAMIC METAL  
SEAL FLATPACK PACKAGE (FLATPACK)  
MIL-STD-1835 CDFP3-F28  
TOP VIEW**

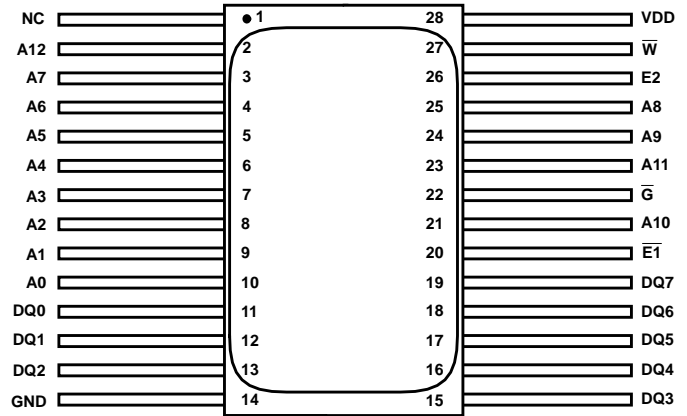

**HS9A-65647RH 36 LEAD CERAMIC METAL  
SEAL FLATPACK PACKAGE (FLATPACK)  
INTERSIL OUTLINE K36.A  
TOP VIEW**

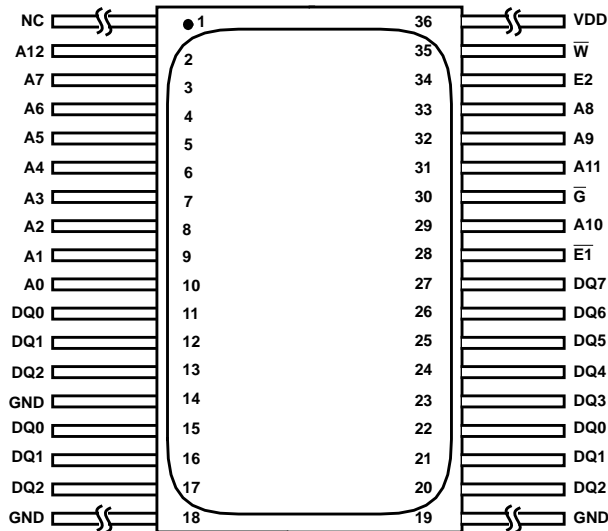

# Specifications HS-65647RH

## Absolute Maximum Ratings

Supply Voltage	+7.0V
Input, Output or I/O Voltage	GND-0.3V to VDD+0.3V
Storage Temperature Range	-65°C to +150°C
Junction Temperature	+175°C
Lead Temperature (Soldering 10s)	+300°C
Typical Derating Factor	3mA/MHz Increase in IDDOP
ESD Classification	Class 1

## Reliability Information

Thermal Resistance	$\theta_{JA}$	$\theta_{JC}$
28 Lead SBDIP Package	45°C/W	8.0°C/W
28/36 Lead Ceramic Flatpack Package	53.4°C/W	7.4°C/W
Maximum Package Power Dissipation at +125°C Ambient		
28 Lead SBDIP Package	1.11W	
28/36 Lead Ceramic Flatpack Package	0.94W	
If device power exceeds package dissipation capability, provide heat sinking or derate linearly at the following rate:		
28 Lead SBDIP Package	.22.2mW/C	
28/36 Lead Ceramic Flatpack Package	.18.7mW/C	

*CAUTION: Stresses above those listed in "Absolute Maximum Ratings" may cause permanent damage to the device. This is a stress only rating and operation of the device at these or any other conditions above those indicated in the operational sections of this specification is not implied.*

## Operating Conditions

Operating Voltage Range (VDD)	+4.5V to +5.5V	Input High Voltage (VIH)	.0.8VDD to VDD
Operating Temperature Range (TA)	-55°C to +125°C	Data Retention Supply Voltage	2.0V
Input Low Voltage (VIL)	0V to +0.2VDD	Input Rise and Fall Time	40ns Max.

**TABLE 1. DC ELECTRICAL PERFORMANCE CHARACTERISTICS**

PARAMETER	SYMBOL	(NOTE 1) CONDITIONS	GROUP A SUBGROUPS	TEMPERATURE	LIMITS		UNITS
					MIN	MAX	
High Level Output Voltage	VOH	VDD = 4.5V, IO = -5mA VI = VDD or GND	1, 2, 3	-55°C, +25°C, +85°C, +125°C	VDD- 0.4	-	V
Low Level Output Voltage	VOL	VDD = 4.5V, IO = 8.0mA VI = VDD or GND	1, 2, 3	-55°C, +25°C, +85°C, +125°C	-	0.4	V
High Impedance Output Leakage Current	IOZL or IOZH	VDD = 5.5V, VO = GND or VDD, VI = VDD or GND E1 = VDD, E2 = 0V	1, 3	-55°C, +25°C	-10	10	µA
			2	+85°C	-30	30	µA
			2	+125°C	-60	60	µA
Input Leakage Current	IIH or IIL	VDD = 5.5V, VI = VDD or GND	1, 2, 3	-55°C, +25°C, +85°C, +125°C	-1.0	1.0	µA
Standby Supply Current	IDDSB (Note 3)	VDD = 5.5V, IO = 0mA, VI = VDD or GND E1 = VDD, E2 = 0V	1, 3	-55°C, +25°C	-	500	µA
			2	+85°C	-	4	mA
			2	+125°C	-	10	mA
Enable Supply Current	IDDEN	VDD = 5.5V, IO = 0mA, VI = VDD or GND E1 = 0.0V, E2 = VDD	3	-55°C	-	77	mA
			1	+25°C	-	73	mA
			2	+85°C, +125°C	-	64	mA
Operating Supply Current (Note 2)	IDDOP	VDD = 5.5V, IO = 0mA, VI = VDD or GND, E2 = VDD, E1 = 0V, f = 2MHz	3	-55°C	-	100	mA
			1	+25°C	-	86	mA
			2	+85°C, +125°C	-	75	mA
Data Retention Supply Current	IDDDR	VDD = 2.0V, IO = 0mA, VI = VDD or GND E1 = VDD, E2 = 0V	1, 3	-55°C, +25°C	-	50	µA
			2	+85°C	-	1	mA
			2	+125°C	-	4	mA
Functional Tests	FT	VDD = 4.5V and 5.5V VI = VDD or GND, f = 1MHz	7, 8A, 8B	-55°C, +25°C, +85°C, +125°C	-	-	-
Noise Immunity Functional Test	FN	VDD = 4.5, VIL = 0.2 VDD VIH = 0.8 VDD, f = 1MHz	7, 8A, 8B	-55°C, +25°C, +85°C, +125°C	-	-	-

**NOTES:**

1. All voltages referenced to device GND.
2. Typical IDDOP derating = 3mA/MHz (3mA increase in IDDOP per 1MHz increase in address frequency.)
3. In order for this device to be in low power standby mode. E2 must be disabled (low).

## Specifications HS-65647RH

**TABLE 2. AC ELECTRICAL PERFORMANCE CHARACTERISTICS**

PARAMETER	SYMBOL	(NOTES 1, 2, 3) CONDITIONS	GROUP A SUBGROUPS	TEMPERATURE	LIMITS		UNITS
					MIN	MAX	
Address Access Time	TAVQV	VDD = 4.5V	9, 10, 11	-55°C, +25°C, +85°C, +125°C	-	50	ns
Output Enable Access Time	TGLQV	VDD = 4.5V	9, 10, 11	-55°C, +25°C, +85°C, +125°C	-	15	ns
Chip Enable Access Time	TE1LQV TE2HQV	VDD = 4.5V	9, 10, 11	-55°C, +25°C, +85°C, +125°C	-	50	ns
Write Recovery Time	TWHAX TE1HAX TE2LAX	VDD = 4.5V	9, 10, 11	-55°C, +25°C, +85°C, +125°C	0	-	ns
Chip Enable to End-of-Write	TE1LE1H TE2HE2L	VDD = 4.5V	9, 10, 11	-55°C, +25°C, +85°C, +125°C	35	-	ns
Address Setup Time	TAVWL TAVE1L TAVE2H	VDD = 4.5V	9, 10, 11	-55°C, +25°C, +85°C, +125°C	5	-	ns
Write Enable Pulse Width	TWLWH	VDD = 4.5V	9, 10, 11	-55°C, +25°C, +85°C, +125°C	25	-	ns
Data Setup Time	TDVWH	VDD = 4.5V	9, 10, 11	-55°C, +25°C, +85°C, +125°C	30	-	ns
	TDVE1H TDVE2L	VDD = 4.5V	9, 10, 11	-55°C, +25°C, +85°C, +125°C	30	-	ns
Data Hold Time	TWHDX	VDD = 4.5V	9, 10, 11	-55°C, +25°C, +85°C, +125°C	0	-	ns
Address Hold Time	TAVE1H TAVE2L	VDD = 4.5V	9, 10, 11	-55°C, +25°C, +85°C, +125°C	40	-	ns
	TE2LDX TE1HDX	VDD = 4.5V	9, 10, 11	-55°C, +25°C, +85°C, +125°C	0	-	ns

**NOTES:**

1. AC measurements tested at worst case VDD. Guaranteed over full operating range.
2. AC measurements assume transition time ≤ 5ns; input levels = 0.0V to VDD; timing reference levels = 2.0V; output load = 1 TTL equivalent load and CL ≥ 50pF, for CL > 50pF, access times are derated 0.15ns/pF.
3. For timing waveforms, see Low Voltage Data Retention and Read/Write Cycles.

**TABLE 3. ELECTRICAL PERFORMANCE CHARACTERISTICS**

PARAMETER	SYMBOL	CONDITIONS	NOTES	TEMPERATURE	LIMITS		UNITS
					MIN	MAX	
Input Capacitance	CIN	VDD = Open, f = 1MHz	1, 2, 4	T <sub>A</sub> = +25°C	-	12	pF
		VDD = Open, f = 1MHz	1, 2, 4	T <sub>A</sub> = +25°C	-	12	pF
I/O Capacitance	CI/O	VDD = Open, f = 1MHz	1, 2, 4	T <sub>A</sub> = +25°C	-	12	pF
		VDD = Open, f = 1MHz	1, 2, 4	T <sub>A</sub> = +25°C	-	12	pF
Write Enable to Output in High Z	TWLQZ	VDD = 4.5V and 5.5V	1	-55°C ≤ T <sub>A</sub> ≤ +125°C	-	10	ns

## Specifications HS-65647RH

**TABLE 3. ELECTRICAL PERFORMANCE CHARACTERISTICS (Continued)**

PARAMETER	SYMBOL	CONDITIONS	NOTES	TEMPERATURE	LIMITS		UNITS
					MIN	MAX	
Write Enable High to Output ON	TWHQX	VDD = 4.5V and 5.5V	1	$-55^{\circ}\text{C} \leq T_A \leq +125^{\circ}\text{C}$	0	-	ns
Chip Enable to Output ON	TE1LQX TE2HQX	VDD = 4.5V and 5.5V	1	$-55^{\circ}\text{C} \leq T_A \leq +125^{\circ}\text{C}$	0	-	ns
Output Enable to Output ON	TGLQX	VDD = 4.5V and 5.5V	1	$-55^{\circ}\text{C} \leq T_A \leq +125^{\circ}\text{C}$	0	-	ns
Chip Enable to Output in High Z	TE1HQZ TE2LQZ	VDD = 4.5V and 5.5V	1	$-55^{\circ}\text{C} \leq T_A \leq +125^{\circ}\text{C}$	-	15	ns
Output Disable to Output in High Z	TGHQZ	VDD = 4.5V and 5.5V	1	$-55^{\circ}\text{C} \leq T_A \leq +125^{\circ}\text{C}$	-	15	ns
Output Hold from Address Change	TAXQX	VDD = 4.5V and 5.5V	1	$-55^{\circ}\text{C} \leq T_A \leq +125^{\circ}\text{C}$	0	-	ns

**NOTES:**

1. The parameters listed are controlled via design or process parameters and are not directly tested. These parameters are characterized upon initial design release and upon design changes which would affect these characteristics.
2. Applies to DIP device types only.
3. Applies to Flatpack device types only.
4. All measurements referenced to device GND.

**TABLE 4. POST 300K RAD DC ELECTRICAL PERFORMANCE CHARACTERISTICS**

PARAMETER	SYMBOL	CONDITIONS	TEMPERATURE	LIMITS		UNITS
				MIN	MAX	
Standby Supply Current	IDDSB	VDD = 5.5V, IO = 0mA, $\bar{E}1 = VDD$ , E2 = 0V, VI = VDD or GND	+25°C	-	10	mA
Enabled Supply Current	IDDEN	VDD = 5.5V, IO = 0mA, $\bar{E}1 = 0.0V$ , E2 = VDD, VI = VDD or GND	+25°C	-	82	mA
Operating Supply Current (Note 2)	IDDOP	VDD = 5.5V, IO = 0mA, f = 2MHz, $\bar{E} = 0V$ , VI = VDD or GND	+25°C	-	100	mA
Data Retention Supply Current	IDDDR	VDD = 2.0V, IO = 0mA, $\bar{E} = VDD$	+25°C	-	6	mA

**NOTES:**

1. DC parameters not listed in this table are tested at the +25°C pre-irradiation test limits. All AC parameters are tested at the +25°C pre-irradiation test limits.
2. Typical IDDOP derating = 3mA/MHz (3mA increase in IDDOP per 1MHz increase in address frequency.)

**HS-65647RH**

**TABLE 5. BURN-IN DELTA PARAMETERS (+25°C), GROUP B, SUBGROUP 5**

PARAMETER	SYMBOL	DELTA LIMITS
Standby Supply Current	IDDSB	±150µA
High Impedance Output Leakage Current	IOZH, IOZL	± 2µA
Input Leakage Current	IIH, IIL	± 150nA
Low Level Output Voltage	VOL	± 60mV
Output High Voltage	VOH	± 150mV

**TABLE 6. APPLICABLE SUBGROUPS**

CONFORMANCE GROUP	MIL-STD-883 METHOD	GROUP A SUBGROUPS			
		TESTED FOR -Q	RECORDED FOR -Q	TESTED FOR -8	RECORDED FOR -8
Initial Test	100% 5004	1, 7, 9	1 (Note 2)	1, 7, 9	
Interim Test	100% 5004	1, 7, 9, Δ	1, Δ (Note 2)	1, 7, 9	
PDA	100% 5004	1, 7, Δ	-	1, 7	
Final Test	100% 5004	2, 3, 8A, 8B, 10, 11	-	2, 3, 8A, 8B, 10, 11	
Group A (Note 1)	Sample 5005	1, 2, 3, 7, 8A, 8B, 9, 10, 11	-	1, 2, 3, 7, 8A, 8B, 9, 10, 11	
Subgroup B5	Sample 5005	1, 2, 3, 7, 8A, 8B, 9, 10, 11, Δ	1, 2, 3, Δ (Note 2)	N/A	
Subgroup B6	Sample 5005	1, 7, 9	-	N/A	
Group C	Sample 5005	N/A	N/A	1, 2, 3, 7, 8A, 8B, 9, 10, 11	
Group D	Sample 5005	1, 7, 9	-	1, 7, 9	
Group E, Subgroup 2	Sample 5005	1, 7, 9	-	1, 7, 9	

NOTES:

1. Alternate Group A testing in accordance with MIL-STD-883 method 5005 may be exercised.
2. Table 5 parameters only

**Intersil Space Level Product Flow -Q**

Wafer Lot Acceptance (All Lots) Method 5007 (Includes SEM)	100% Interim Electrical Test 1 (T1)
GAMMA Radiation Verification (Each Wafer) Method 1019, 2 Samples/Wafer, 0 Rejects	100% Delta Calculation (T0-T1)
100% Nondestructive Bond Pull, Method 2023	100% PDA 1, Method 5004 (Note 1)
Sample - Wire Bond Pull Monitor, Method 2011	100% Dynamic Burn-In, Condition D, 240 Hours, +125°C or Equivalent, Method 1015
Sample - Die Shear Monitor, Method 2019 or 2027	100% Interim Electrical Test 2(T2)
100% Internal Visual Inspection, Method 2010, Condition A	100% Delta Calculation (T0-T2)
100% Temperature Cycle, Method 1010, Condition C, 10 Cycles	100% PDA 2, Method 5004 (Note 1)
100% Constant Acceleration, Method 2001, Condition per Method 5004	100% Final Electrical Test
100% PIND, Method 2020, Condition A	100% Fine/Gross Leak, Method 1014
100% External Visual	100% Radiographic (X-Ray), Method 2012 (Note 2)
100% Serialization	100% External Visual, Method 2009
100% Initial Electrical Test (T0)	Sample - Group A, Method 5005 (Note 3)
100% Static Burn-In 1, Condition A or B, 72 Hours Min, +125°C Min, Method 1015	Sample - Group B, Method 5005 (Note 4)
	Sample - Group D, Method 5005 (Notes 4 and 5)
	100% Data Package Generation (Note 6)

**NOTES:**

1. Failures from subgroup 1, 7 and deltas are used for calculating PDA. The maximum allowable PDA = 5% with no more than 3% of the failures from subgroup 7.
2. Radiographic (X-Ray) inspection may be performed at any point after serialization as allowed by Method 5004.
3. Alternate Group A testing may be performed as allowed by MIL-STD-883, Method 5005.
4. Group B and D inspections are optional and will not be performed unless required by the P.O. When required, the P.O. should include separate line items for Group B Test, Group Samples, Group D Test and Group D Samples.
5. Group D Generic Data, as defined by MIL-I-38535, is optional and will not be supplied unless required by the P.O. When required, the P.O. should include a separate line item for Group D Generic Data. Generic data is not guaranteed to be available and is therefore not available in all cases.
6. Data Package Contents:
  - Cover Sheet (Intersil Name and/or Logo, P.O. Number, Customer Part Number, Lot Date Code, Intersil Part Number, Lot Number, Quantity).
  - Wafer Lot Acceptance Report (Method 5007). Includes reproductions of SEM photos with percent of step coverage.
  - GAMMA Radiation Report. Contains Cover page, disposition, Rad Dose, Lot Number, Test Package used, Specification Numbers, Test equipment, etc. Radiation Read and Record data on file at Intersil.
  - X-Ray report and film. Includes penetrometer measurements.
  - Screening, Electrical, and Group A attributes (Screening attributes begin after package seal).
  - Lot Serial Number Sheet (Good units serial number and lot number).
  - Variables Data (All Delta operations). Data is identified by serial number. Data header includes lot number and date of test.
  - Group B and D attributes and/or Generic data is included when required by the P.O.
  - The Certificate of Conformance is a part of the shipping invoice and is not part of the Data Book. The Certificate of Conformance is signed by an authorized Quality Representative.

**Intersil Space Level Product Flow -8**

GAMMA Radiation Verification (Each Wafer) Method 1019, 2 Samples/Wafer, 0 Rejects	100% Dynamic Burn-In, Condition D, 160 Hours, +125°C or Equivalent, Method 1015
Periodic- Wire Bond Pull Monitor, Method 2011	100% Interim Electrical Test
Periodic- Die Shear Monitor, Method 2019 or 2027	100% PDA, Method 5004 (Note 1)
100% Internal Visual Inspection, Method 2010, Condition B	100% Final Electrical Test
100% Temperature Cycle, Method 1010, Condition C, 10 Cycles	100% Fine/Gross Leak, Method 1014
100% Constant Acceleration, Method 2001, Condition per Method 5004	100% External Visual, Method 2009
100% External Visual	Sample - Group A, Method 5005 (Note 2)
100% Initial Electrical Test	Sample - Group B, Method 5005 (Note 3)
	Sample - Group C, Method 5005 (Notes 3 and 4)
	Sample - Group D, Method 5005 (Notes 3 and 4)
	100% Data Package Generation (Note 5)

**NOTES:**

1. Failures from subgroup 1, 7 are used for calculating PDA. The maximum allowable PDA = 5%.
2. Alternate Group A testing may be performed as allowed by MIL-STD-883, Method 5005.
3. Group B, C and D inspections are optional and will not be performed unless required by the P.O. When required, the P.O. should include separate line items for Group B Test, Group C Test, Group C Samples, Group D Test and Group D Samples.
4. Group C and/or Group D Generic Data, as defined by MIL-I-38535, is optional and will not be supplied unless required by the P.O. When required, the P.O. should include a separate line item for Group C Generic Data and/or Group D Generic Data. Generic data is not guaranteed to be available and is therefore not available in all cases.
5. Data Package Contents:
  - Cover Sheet (Intersil Name and/or Logo, P.O. Number, Customer Part Number, Lot Date Code, Intersil Part Number, Lot Number, Quantity).
  - GAMMA Radiation Report. Contains Cover page, disposition, Rad Dose, Lot Number, Test Package used, Specification Numbers, Test equipment, etc. Radiation Read and Record data on file at Intersil.
  - Screening, Electrical, and Group A attributes (Screening attributes begin after package seal).
  - Group B, C and D attributes and/or Generic data is included when required by the P.O.
  - The Certificate of Conformance is a part of the shipping invoice and is not part of the Data Book. The Certificate of Conformance is signed by an authorized Quality Representative.

Timing Waveforms

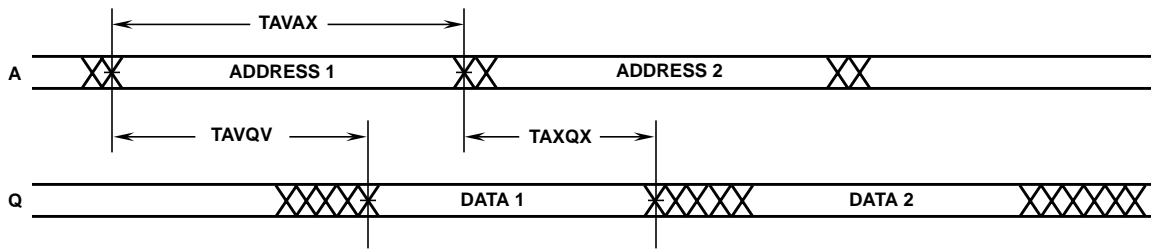

FIGURE 1. READ CYCLE I:  $\bar{W}$ , E2 HIGH;  $\bar{G}$ ,  $\bar{E1}$  LOW

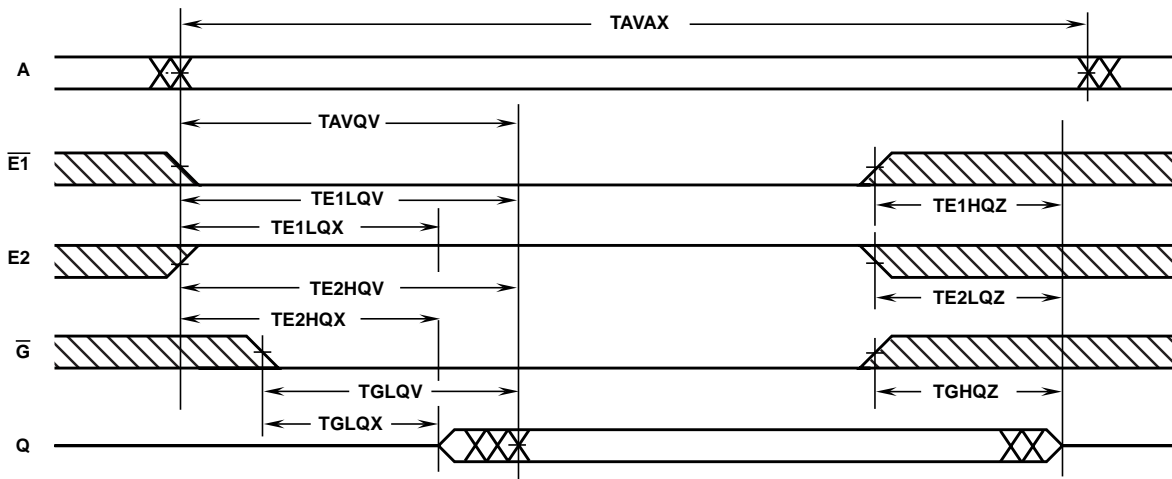

FIGURE 2. READ CYCLE II:  $\bar{W}$  HIGH

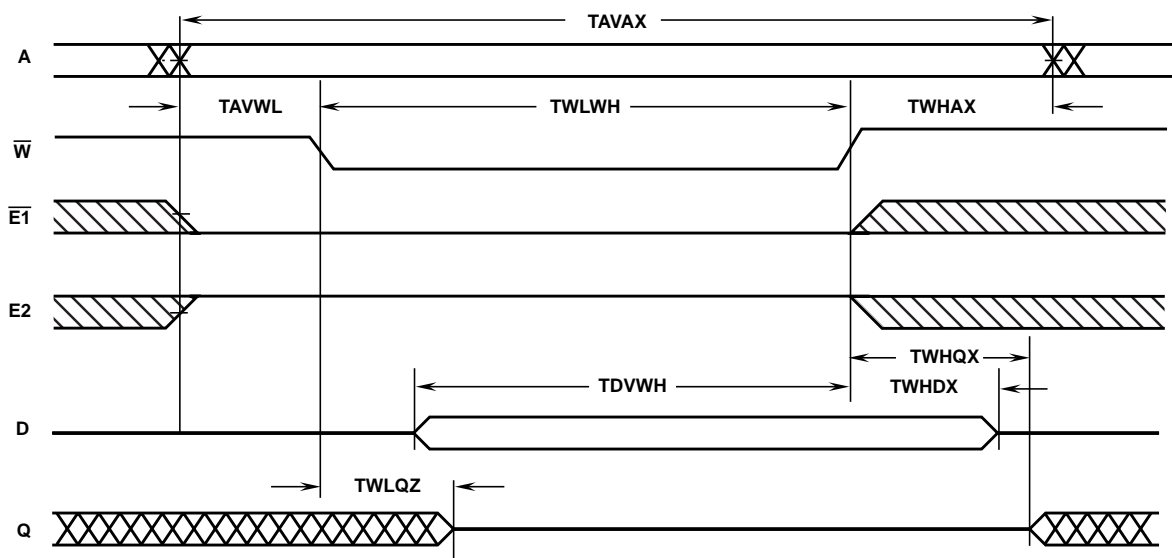

FIGURE 3. WRITE CYCLE I: LATE WRITE

Timing Waveforms (Continued)

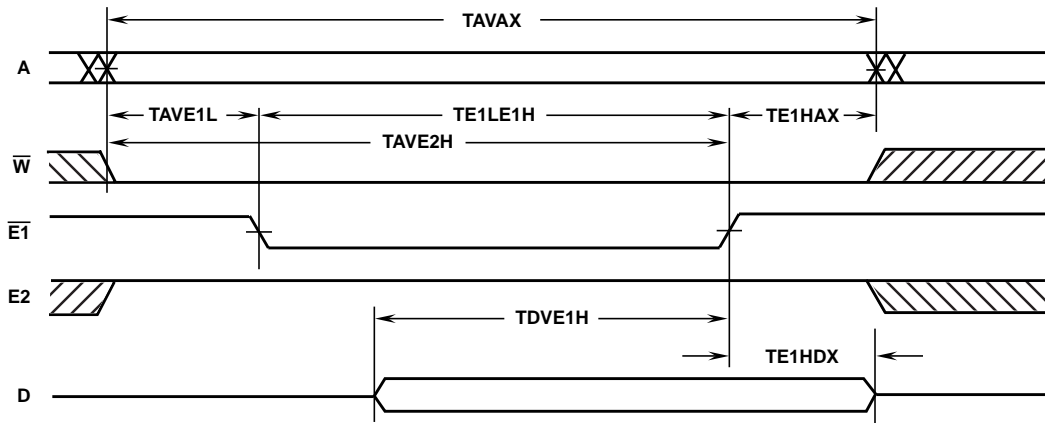

FIGURE 4. WRITE CYCLE II: EARLY WRITE - CONTROLLED BY  $\bar{E}1$

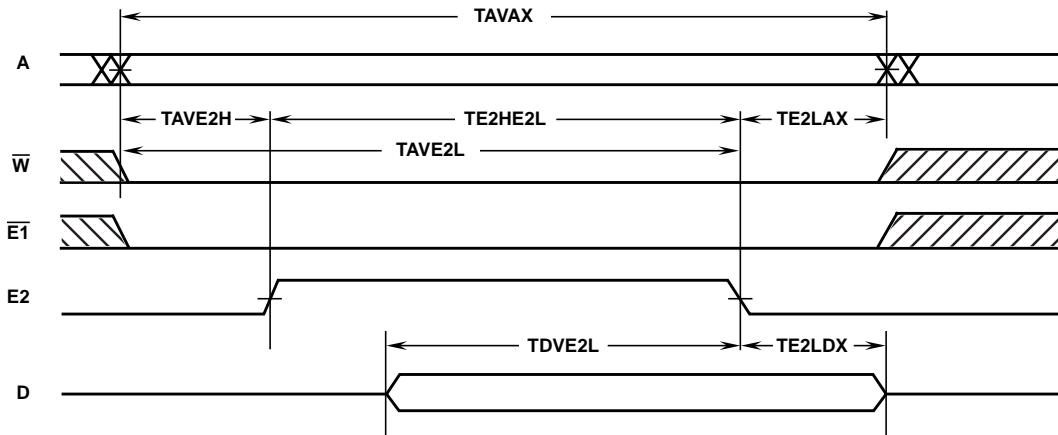

FIGURE 5. WRITE CYCLE III: EARLY WRITE - CONTROLLED BY E2

Performance Curves

HS-65647RH TYPICAL PERFORMANCE CHARACTERISTICS

T<sub>A</sub> = +25°C, Unless Otherwise Specified

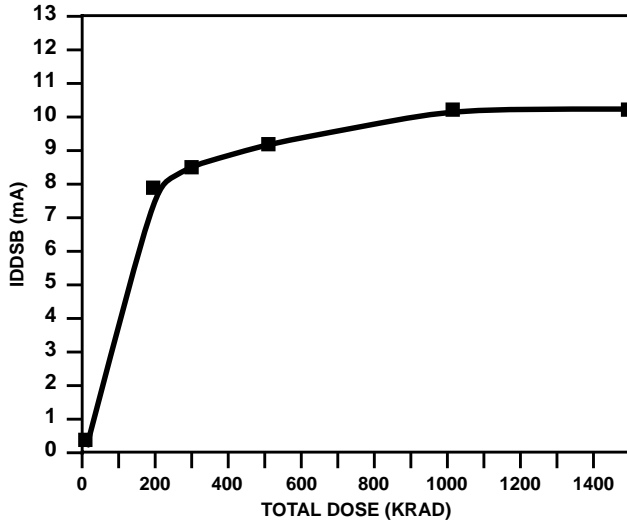

FIGURE 6

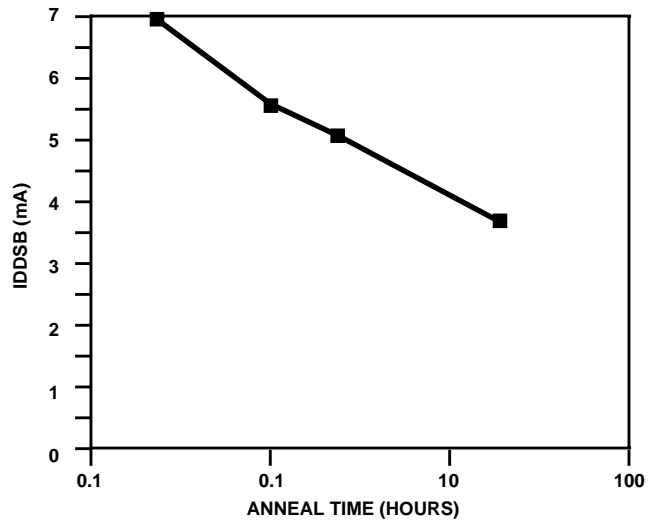

FIGURE 7

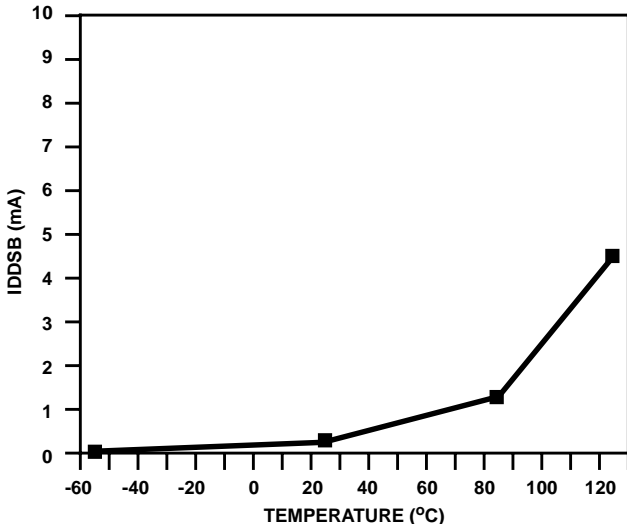

FIGURE 8

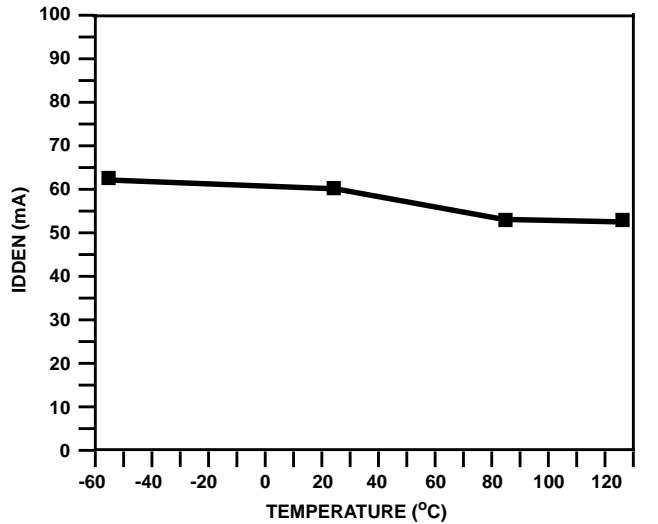

FIGURE 9

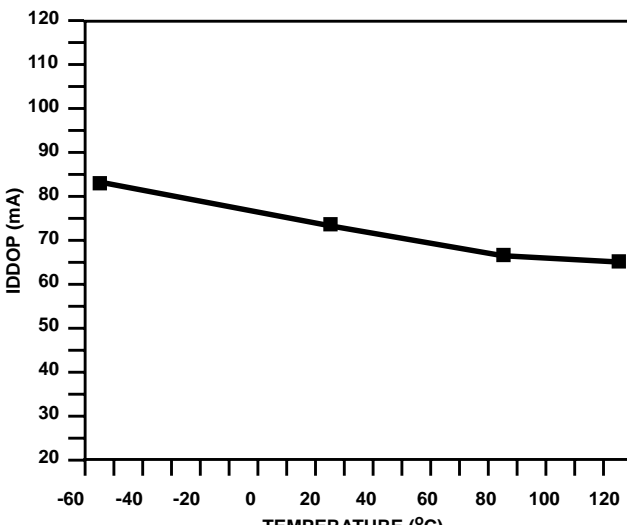

FIGURE 10

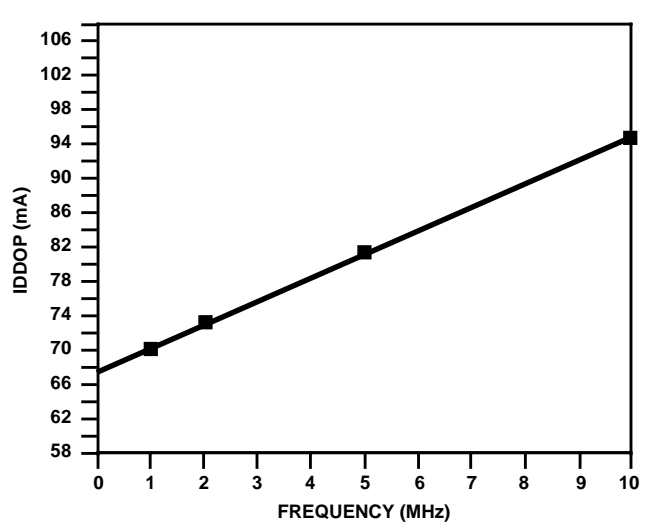

FIGURE 11



# HS-65647RH

## Irradiation Circuit

HS-65647RH (8K x 8 TSOS4 SRAM) 28 LEAD CERAMIC DIP

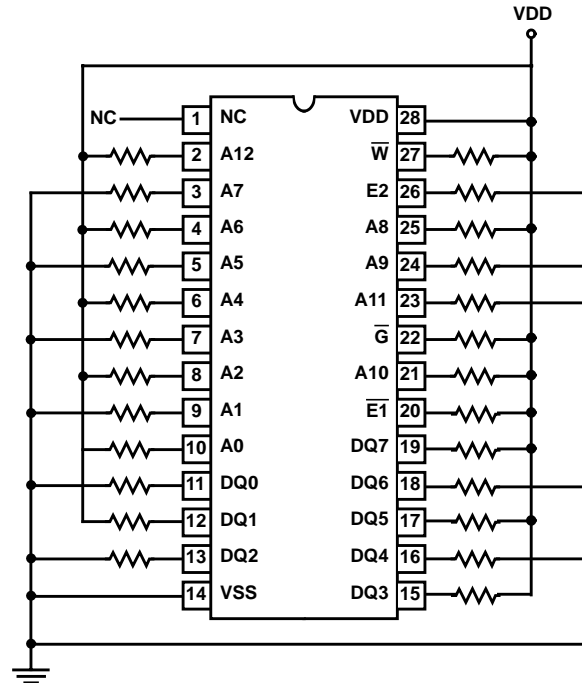

### NOTES:

1. VDD = 5.5V ± 0.5V  
R = 10kΩ ± 10%
2. Group E sample size is two die/wafer.

## Test Patterns

### MARCH (II)PATTERN

After a background of zeros is written, each cell (from beginning to end in sequence) is read, written to a one and reread. When the array is full of ones each cell (from the end to the beginning) is read, restored to a zero and reread.

After this the pattern is repeated but with complemented data.

### MASEST PATTERN (Multiple Address Select Pattern)

A checkerboard pattern is written into the memory. Then the first cell is read, then its binary address complement is read. The second cell is read and then its binary address complement is read. This pattern of incrementing the address and then reading its binary address complement is repeated until the entire memory is read.

This is then repeated but using a checkerboard bar pattern.

### GALROW PATTERN (Row Galloping Pattern)

After a background of zeros is written into the memory a one is written into the first cell. It is then read alternately with

each other cell in the row. The test cell is then rewritten back to a zero. The test cell is then incremented and the sequence is repeated until all cells in the memory have been used as a test cell.

This is pattern then repeated but using complemented data.

### GALCOL PATTERN (Column Galloping Pattern)

After a background of zeros is written into the memory a one is written into the first cell. It is then read alternately with each other cell in the column. The test cell is then rewritten back to a zero. The test cell is then incremented and the sequence is repeated until all cells in the memory have been used as a test cell.

This is pattern then repeated but using complemented data.

### CHECKERBOARD PATTERN and CHECKERBOARD BAR

A checkerboard is written (101010) into the memory and then the pattern is read back. This is then repeated but using complemented data.

# HS-65647RH

## Metallization Topology

### DIE DIMENSIONS:

313 x 291 x 21 ±1mils

### METALLIZATION:

Type: Al/Si/Cu

Metal 1 Thickness: 7500Å ± 2kÅ

Metal 2 Thickness: 10kÅ ± 2kÅ

### GLASSIVATION:

Type: SiO<sub>2</sub>

Thickness: 8kÅ ± 1kÅ

### WORST CASE CURRENT DENSITY:

1.5 x 10<sup>5</sup> Amps/cm<sup>2</sup>

## Metallization Mask Layout

HS-65647RH

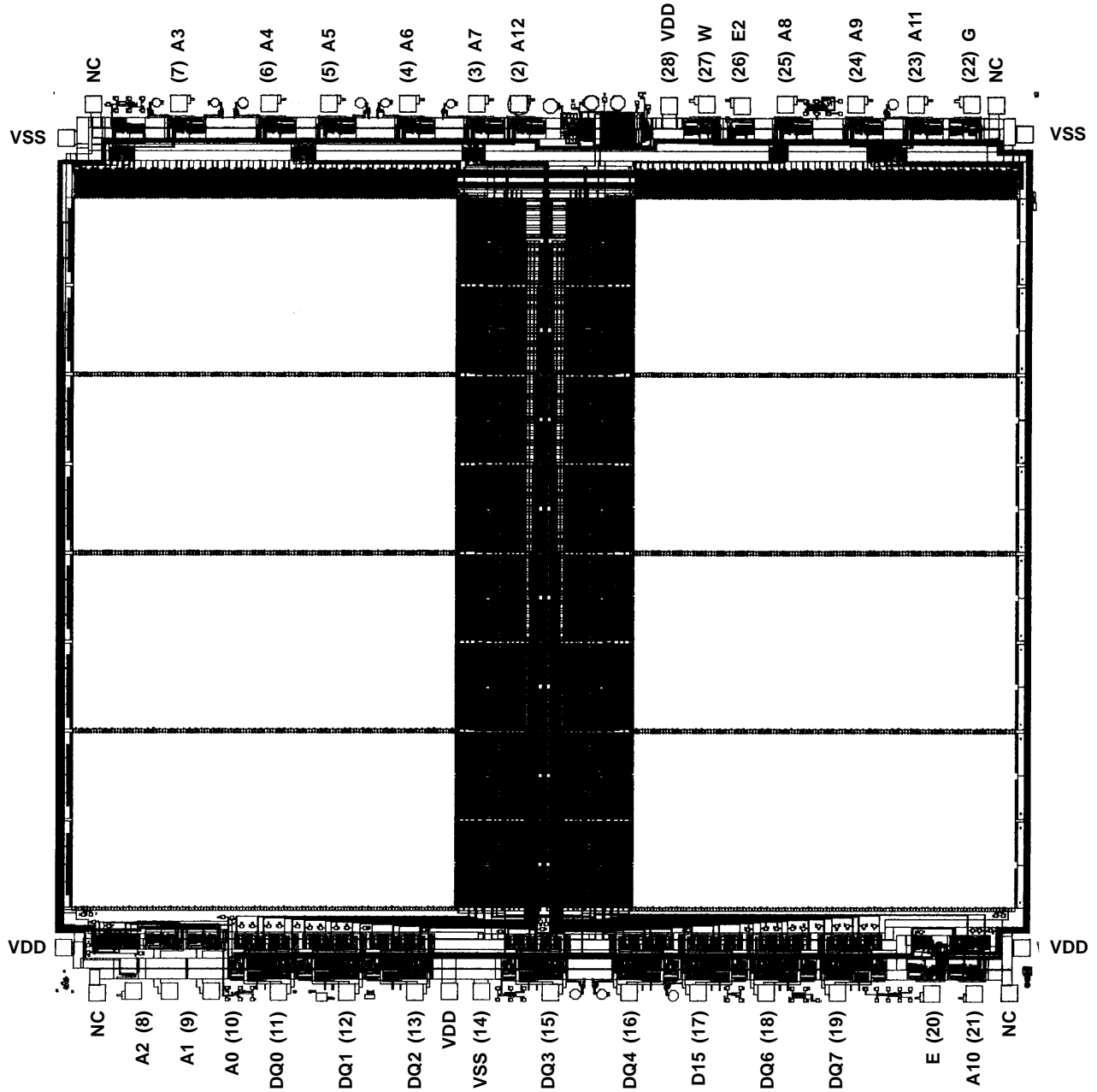

Packaging

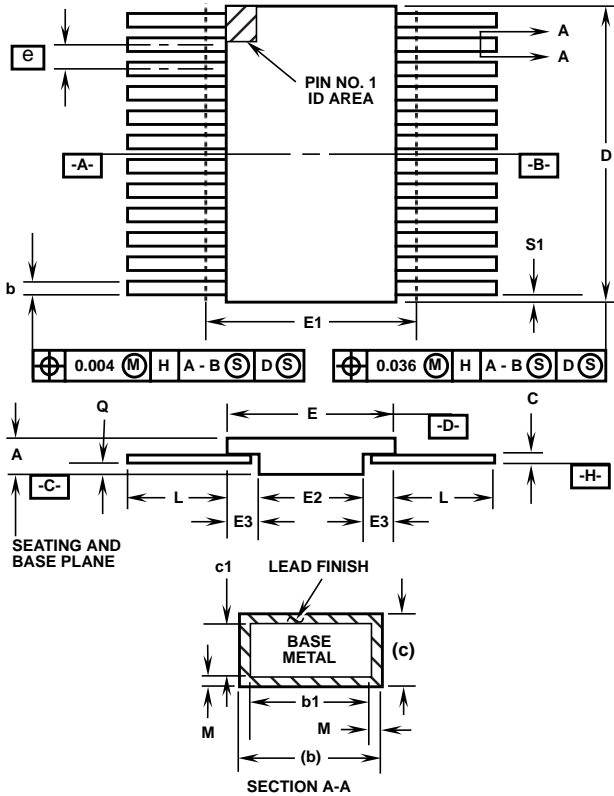

K36.A  
36 LEAD CERAMIC METAL SEAL FLATPACK PACKAGE

SYMBOL	INCHES		MILLIMETERS		NOTES
	MIN	MAX	MIN	MAX	
A	-	0.138	-	3.51	-
b	0.006	0.013	0.15	0.33	-
b1	0.006	0.010	0.15	0.25	-
c	0.004	0.011	0.10	0.28	-
c1	0.004	0.008	0.10	0.20	-
D	0.620	0.640	15.75	16.26	3
E	0.620	0.640	15.75	8.64	-
E1	-	0.660	-	16.76	3
E2	0.470	0.490	11.94	12.45	-
E3	0.030	-	0.76	-	7
e	0.025 BSC		0.64 BSC		-
k	-	-	-	-	-
L	0.240	0.280	6.10	7.11	-
Q	0.026	0.045	0.66	1.14	8
S1	-	-	-	-	-
M	-	0.0015	-	0.04	-
N	36		36		-

Rev. 0 5/18/94

NOTES:

1. Index area: A notch or a pin one identification mark shall be located adjacent to pin one and shall be located within the shaded area shown. The manufacturer's identification shall not be used as a pin one identification mark. Alternately, a tab (dimension k) may be used to identify pin one.
2. If a pin one identification mark is used in addition to a tab, the limits of dimension k do not apply.
3. This dimension allows for off-center lid, meniscus, and glass overrun.
4. Dimensions b1 and c1 apply to lead base metal only. Dimension M applies to lead plating and finish thickness. The maximum limits of lead dimensions b and c or M shall be measured at the centroid of the finished lead surfaces, when solder dip or tin plate lead finish is applied.
5. N is the maximum number of terminal positions.
6. Measure dimension S1 at all four corners.
7. For bottom-brazed lead packages, no organic or polymeric materials shall be molded to the bottom of the package to cover the leads.
8. Dimension Q shall be measured at the point of exit (beyond the meniscus) of the lead from the body. Dimension Q minimum shall be reduced by 0.0015 inch (0.038mm) maximum when solder dip lead finish is applied.
9. Dimensioning and tolerancing per ANSI Y14.5M - 1982.
10. Controlling dimension: INCH.

All Intersil semiconductor products are manufactured, assembled and tested under **ISO9000** quality systems certification.

*Intersil products are sold by description only. Intersil Corporation reserves the right to make changes in circuit design and/or specifications at any time without notice. Accordingly, the reader is cautioned to verify that data sheets are current before placing orders. Information furnished by Intersil is believed to be accurate and reliable. However, no responsibility is assumed by Intersil or its subsidiaries for its use; nor for any infringements of patents or other rights of third parties which may result from its use. No license is granted by implication or otherwise under any patent or patent rights of Intersil or its subsidiaries.*

For information regarding Intersil Corporation and its products, see web site <http://www.intersil.com>

### **Sales Office Headquarters**

#### **NORTH AMERICA**

Intersil Corporation  
P. O. Box 883, Mail Stop 53-204  
Melbourne, FL 32902  
TEL: (407) 724-7000  
FAX: (407) 724-7240

#### **EUROPE**

Intersil SA  
Mercure Center  
100, Rue de la Fusee  
1130 Brussels, Belgium  
TEL: (32) 2.724.2111  
FAX: (32) 2.724.22.05

#### **ASIA**

Intersil (Taiwan) Ltd.  
Taiwan Limited  
7F-6, No. 101 Fu Hsing North Road  
Taipei, Taiwan  
Republic of China  
TEL: (886) 2 2716 9310  
FAX: (886) 2 2715 3029

This datasheet has been downloaded from:

[www.DatasheetCatalog.com](http://www.DatasheetCatalog.com)

Datasheets for electronic components.



LittleDiode supplies new, hard to find or obsolete electronic components and semiconductors all over the world.

With over two million different components listed you are sure to find the part you need.

Feel free to visit us today at our online store:

[LittleDiode.com](http://LittleDiode.com)

Looking forward to providing you with the best possible service.