

FEATURES

- ±0.2 LSB (±0.00031%) Typ Peak DNL and INL
- ±0.5 LSB (±0.00076%) Typ Unipolar Offset, Bipolar Zero
- 17-Bit Monotonicity Guaranteed
- 18-Bit Resolution (in Serial Mode)
- Complete 16/18-Bit D/A Function
- On-Chip Output Amplifier
- On-Chip Buried Zener Voltage Reference
- Microprocessor Compatible
- Serial or Byte Input
- Double Buffered Latches
- Asynchronous Clear Function
- Serial Output Pin Facilitates Daisy Chaining
- Pin Strappable Unipolar or Bipolar Output
- Low THD+N: 0.005%
- MUX Output Control on Power-Up and Supply Glitches

PRODUCT DESCRIPTION

The AD760 is a complete 16/18-bit self-calibrating monolithic DAC (DACPORT®) with onboard voltage reference, double buffered latches and output amplifier. It is manufactured on Analog Devices' BiMOS II process. This process allows the fabrication of low power CMOS logic functions on the same chip as high precision bipolar linear circuitry.

Self-calibration is initiated by simply pulsing the $\overline{\text{CAL}}$ pin low. The CALOK pin indicates when calibration has been successfully completed. The output multiplexer (MUX_{OUT}) can be used to send the output to the bottom of the output range during calibration.

Data can be loaded into the AD760 as straight binary, serial data or as two 8-bit bytes. In serial mode, 16-bit or 18-bit data can be used and the serial mode input format is pin selectable, to be MSB or LSB first. This is made possible by three digital input pins which have dual functions (Pins 12, 13, and 14). In byte mode the user can similarly define whether the high byte or low byte is loaded first. The serial output (S_{OUT}) pin allows the user to daisy chain several AD760s by shifting the data through the input latch into the next DAC thus minimizing the number of control lines required in a multiple DAC application. The double buffered latch structure eliminates data skew errors and provides for simultaneous updating of DACs in a multi-DAC system.

The asynchronous $\overline{\text{CLR}}$ function can be configured to clear the output to minus full-scale or midscale depending on the state of Pin 17 when $\overline{\text{CLR}}$ is strobed. The AD760 also powers up with the

REV. A

Information furnished by Analog Devices is believed to be accurate and reliable. However, no responsibility is assumed by Analog Devices for its use, nor for any infringements of patents or other rights of third parties which may result from its use. No license is granted by implication or otherwise under any patent or patent rights of Analog Devices.

FUNCTIONAL BLOCK DIAGRAM

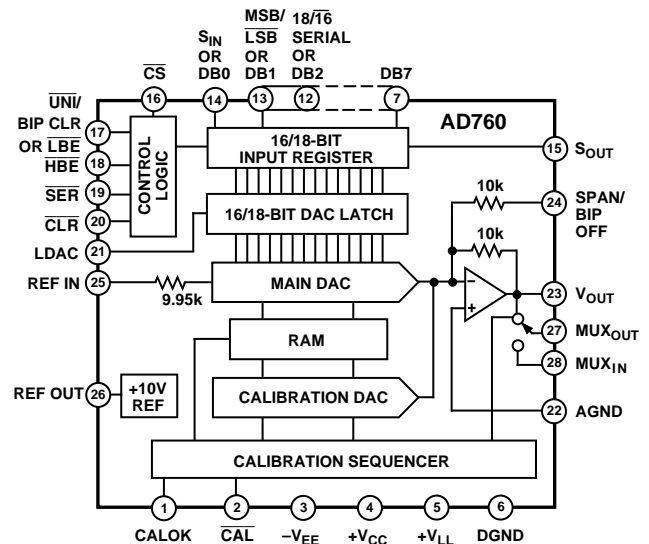

MUX output in a predetermined state by means of a digital and analog power supply detection circuit. This is particularly useful for robotic and industrial control applications.

The AD760 is available in a 28-pin, 600 mil cerdip package. The AQ version is specified from -40°C to +85°C.

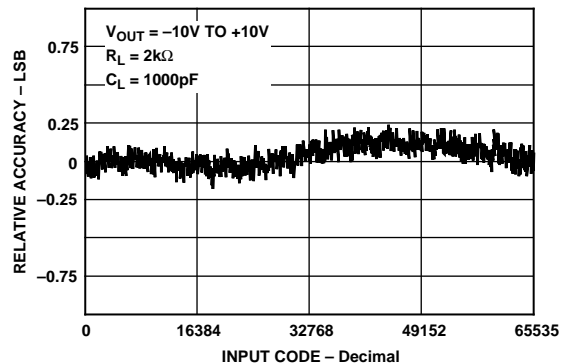

Typical Integral Nonlinearity

DACPORT is a registered trademark of Analog Devices, Inc.

© Analog Devices, Inc., 1995

One Technology Way, P.O. Box 9106, Norwood, MA 02062-9106, U.S.A.
Tel: 617/329-4700 Fax: 617/326-8703

AD760—SPECIFICATIONS (@ $T_A = +25^\circ\text{C}$, $V_{CC} = +15\text{ V}$, $V_{EE} = -15\text{ V}$, $V_{LL} = +5\text{ V}$, unless otherwise noted)

Model	AD760AQ			Units	
	Min	Typ	Max		
RESOLUTION ¹	16/18			Bits	
TRANSFER FUNCTION CHARACTERISTICS ²					
With Calibration @ T_{CAL}^3 ; -40°C T_{CAL} $+85^\circ\text{C}$					
Integral Nonlinearity		± 0.2	± 0.75	16-Bit LSB	
Differential Nonlinearity		± 0.2	± 0.5	16-Bit LSB	
Monotonicity	17	18		Bits	
Unipolar Offset		± 0.5	± 1	16-Bit LSB	
Bipolar Zero Error		± 0.5	± 1	16-Bit LSB	
Without Calibration					
Integral Nonlinearity			± 2	16-Bit LSB	
T_{MIN} to T_{MAX}			± 4	16-Bit LSB	
Integral Nonlinearity Drift		0.015		16-Bit LSB/ $^\circ\text{C}$	
Differential Nonlinearity			± 2	16-Bit LSB	
T_{MIN} to T_{MAX}			± 4	16-Bit LSB	
Differential Nonlinearity Drift		0.015		16-Bit LSB/ $^\circ\text{C}$	
Monotonicity Over Temperature	14			Bits	
Unipolar Offset			± 2.5	mV	
Unipolar Offset Drift (T_{MIN} to T_{MAX})			3	ppm/ $^\circ\text{C}$	
Bipolar Zero Error			± 10	mV	
Bipolar Zero Error Drift (T_{MIN} to T_{MAX})			5	ppm/ $^\circ\text{C}$	
Gain Error ^{4,5}			± 0.10	% of FSR	
Gain Drift ⁵ (T_{MIN} to T_{MAX})			25	ppm/ $^\circ\text{C}$	
DAC Gain Error ⁶			± 0.05	% of FSR	
DAC Gain Drift ⁶ (T_{MIN} to T_{MAX})			10	ppm/ $^\circ\text{C}$	
INPUT RESISTANCE					
REFIN	7	10	13	k	
SPAN/BIP OFF	7	10	13	k	
REFERENCE OUTPUT					
Voltage	9.99	10.00	10.01	V	
Drift			25	ppm/ $^\circ\text{C}$	
External Current ⁷	2	4		mA	
Capacitive Load			1000	pF	
Short Circuit Current		25		mA	
Long-Term Stability		50		ppm/1000 Hrs	
OUTPUT CHARACTERISTICS ²					
Output Voltage Range					
Unipolar Configuration	0		+10	V	
Bipolar Configuration	-10		+10	V	
Output Current	5			mA	
Capacitive Load			1000	pF	
Short Circuit Current		25		mA	
MUX _{OUT} Resistance	0.9		7	k	
DIGITAL INPUTS (T_{MIN} to T_{MAX})					
V_{IH} (Logic "1")	2.0		V_{LL}	V	
V_{IL} (Logic "0")	0		0.8	V	
I_{IH} ($V_{IH} = V_{LL}$)			± 10	μA	
I_{IL} ($V_{IL} = 0\text{ V}$)			± 10	μA	
DIGITAL OUTPUT (T_{MIN} to T_{MAX})					
V_{OH} ($I_{OH} = -0.6\text{ mA}$)	2.4			V	
V_{OL} ($I_{OL} = 1.6\text{ mA}$)			0.4	V	
POWER SUPPLIES					
Voltage					
V_{CC} ⁸	+14.25		+15.75	V	
V_{EE} ⁸	-15.75		-14.25	V	
V_{LL}	+4.75		+5.25	V	
Current (No Load)					
I_{CC}		+18	+21	mA	
I_{EE}	-21	-18		mA	
I_{LL}					
@ V_{IH} , $V_{IL} = 5.0\text{ V}$, 0 V		2	3	mA	
@ V_{IH} , $V_{IL} = 2.4\text{ V}$, 0.4 V		3	7.5	mA	
Power Supply Sensitivity with $V_{OUT} = 10\text{ V}$			1	ppm/%	
Power Dissipation (Static, No Load)		600	725	mW	
TEMPERATURE RANGE					
Specified Performance (A)	-40			+85	$^\circ\text{C}$

NOTES

¹For 18-bit resolution, 1 LSB = 0.00038% of FSR. For 16-bit resolution, 1 LSB = 0.0015% of FSR. For 14-bit resolution, 1 LSB = 0.006% of FSR. FSR stands for full-scale range and is 10 V in unipolar mode and 20 V in bipolar mode.

²Characteristics are guaranteed at V_{OUT} Pin (23).

³ T_{CAL} is the calibration temperature.

⁴Gain Error is measured with a fixed 50 Ω resistor as shown in Figure 5a and Figure 6a.

⁵Gain Error and gain drift are measured with the internal reference. The internal reference is the main contributor to the gain drift. If lower drift is required, the AD760 can be used with a precision external reference such as the AD587, AD586 or AD688.

⁶DAC Gain Error is measured without the on-chip voltage reference. It represents the performance that can be obtained with an external precision reference.

⁷External current is defined as the current available in addition to that supplied to REF IN and SPAN/BIPOLAR OFFSET on the AD760.

⁸Operation on ± 12 V supplies is possible using an external reference such as the AD586 and reducing the output range. Refer to the Internal/External Reference section.

Specifications subject to change without notice.

AC PERFORMANCE CHARACTERISTICS

With the exception of Total Harmonic Distortion + Noise and Signal-to-Noise Ratio, these characteristics are included for design guidance only and are not subject to test. THD+N and SNR are 100% tested. ($T_{MIN} < T_A < T_{MAX}$, $V_{CC} = +15$ V, $V_{EE} = -15$ V, $V_{LL} = +5$ V, tested at V_{OUT} except where noted.)

Parameter	Limit	Units	Test Conditions/Comments
Output Settling Time (Time to +0.0008% FS, with 2 k Ω , 1000 pF Load)	13	μ s max	20 V Step, $T_A = +25^\circ\text{C}$
	8	μ s typ	20 V Step, $T_A = +25^\circ\text{C}$
	10	μ s typ	20 V Step
	6	μ s typ	10 V Step, $T_A = +25^\circ\text{C}$
	8	μ s typ	10 V Step
	2.5	μ s typ	1 LSB Step
MUX _{OUT} Recovery Time (Time to +0.0008% FS, with 100 pF Load)	2	μ s typ	Recovery time is referenced to the rising edge of CALOK, when MUX _{OUT} switches from MUX _{IN} to V _{OUT} . MUX _{IN} = V _{OUT} prior to calibration. MUX _{IN} , V _{OUT} = -10 V to +10 V
Total Harmonic Distortion + Noise A, S Grade A, S Grade A, S Grade	0.005	% max	0 dB, 1001 Hz. Sample Rate = 100 kHz. $T_A = +25^\circ\text{C}$
	0.03	% max	-20 dB, 1001 Hz. Sample Rate = 100 kHz. $T_A = +25^\circ\text{C}$
	3.0	% max	-60 dB, 1001 Hz. Sample Rate = 100 kHz. $T_A = +25^\circ\text{C}$
Signal-to-Noise Ratio	94	dB min	$T_A = +25^\circ\text{C}$, byte load
Digital-to-Analog Glitch Impulse	15	nV-s typ	DAC alternately loaded with 8000 _H and 7FFF _H
MUX _{OUT} Glitch Impulse	30	nV-s typ	100 pF Load. MUX _{IN} = V _{OUT} = negative full scale
Digital Feedthrough	2	nV-s typ	DAC alternately loaded with 0000 _H and FFFF _H . \overline{CS} high
Output Noise Voltage Density (1 kHz–1 MHz)	120	nV/ $\sqrt{\text{Hz}}$ typ	Measured at V _{OUT} , 20 V span, excludes internal reference
Reference Noise (1 kHz–1 MHz)	125	nV/ $\sqrt{\text{Hz}}$ typ	Measured at REF OUT

Specifications are subject to change without notice.

AD760

TIMING CHARACTERISTICS ($V_{CC} = +15\text{ V}$, $V_{EE} = -15\text{ V}$, $V_{LL} = +5\text{ V}$, $V_{IH} = 2.4\text{ V}$, $V_{IL} = 0.4\text{ V}$)

Parameter	Limit		Units
	+25°C	T_{MIN} to T_{MAX}	
(Figure 1a)			
t_{CS}	50	60	ns min
t_{DS}	50	60	ns min
t_{DH}	0	10	ns min
t_{BES}	50	60	ns min
t_{BEH}	0	10	ns min
t_{LH}	200	350	ns min
t_{LW}	50	50	ns min
(Figure 1b)			
t_{CLK}	80	100	ns min
t_{LO}	40	50	ns min
t_{HI}	40	50	ns min
t_{DS}	50	60	ns min
t_{DH}	0	10	ns min
t_{LH}	200	350	ns min
t_{LW}	50	50	ns min
t_{PROP}	70	100	ns max

Parameter	Limit		Units
	+25°C	T_{MIN} to T_{MAX}	
(Figure 1c)			
t_{CLR}	100	120	ns min
t_{SET}	100	120	ns min
t_{HOLD}	0	0	ns min
(Figure 1d)			
t_{CAL}	50	50	ns min
t_{BUSY}	200	200	ms max
t_{CD}	170	220	ns max
t_{CS}	150	190	ns max
t_{CV}	150	190	ns max

Specifications subject to change without notice.

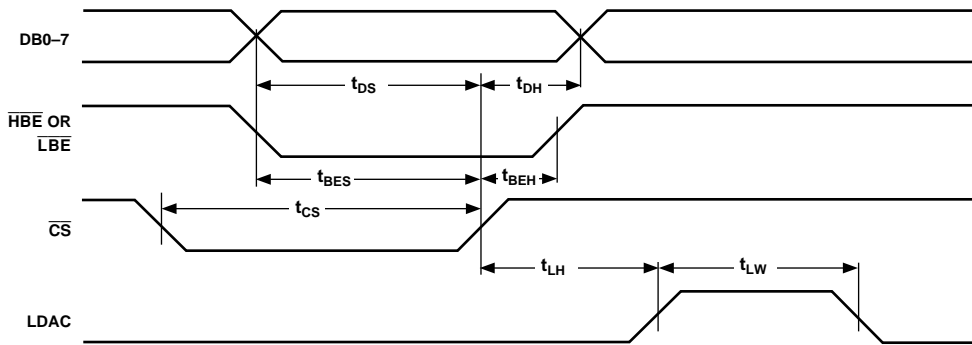

Figure 1a. AD760 Byte Load Timing

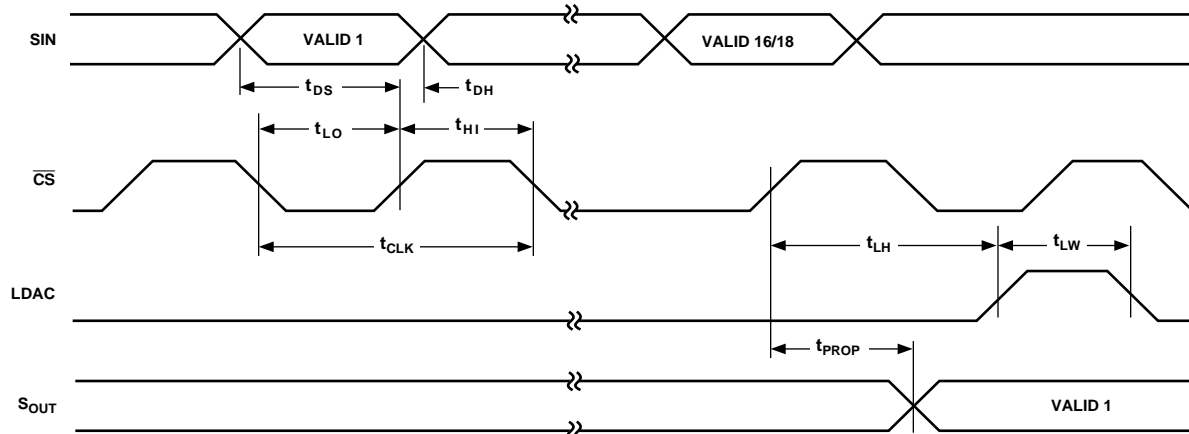

Figure 1b. AD760 Serial Load Timing

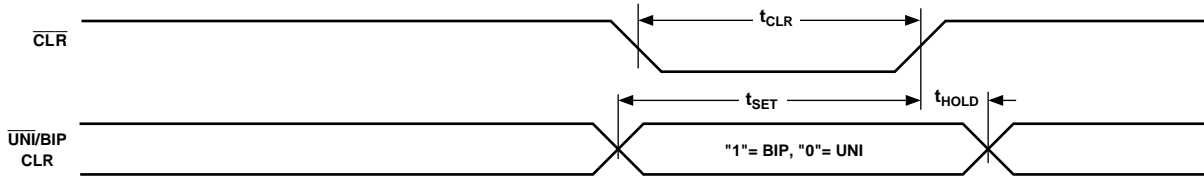

Figure 1c. Asynchronous Clear to Bipolar or Unipolar Zero

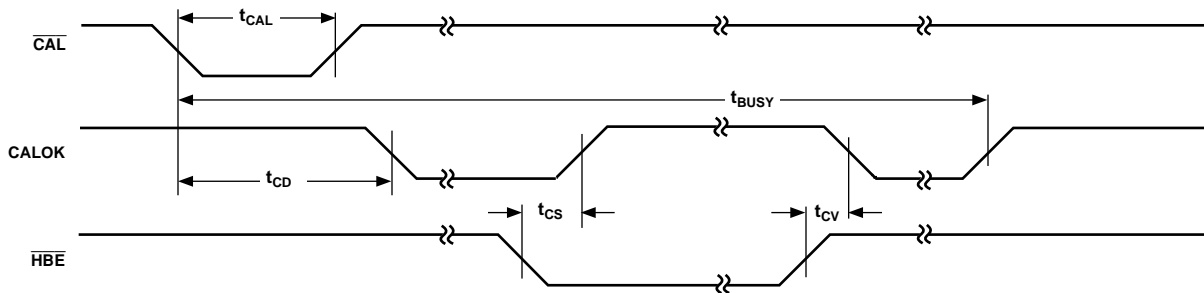

Figure 1d. Calibration Timing

ABSOLUTE MAXIMUM RATINGS*

- V_{CC} to AGND -0.3 V to +17.0 V
- V_{EE} to AGND +0.3 V to -17.0 V
- V_{LL} to DGND -0.3 V to +7 V
- AGND to DGND ±1 V
- Digital Inputs (Pins 2, 7-14, and 16-21)
to DGND -1.0 V to +7.0 V
- REF IN to AGND ±10.5 V
- Span/Bipolar Offset to AGND ±10.5 V
- REF OUT, V_{OUT}, MUX_{OUT}, MUX_{IN} Indefinite Short to
AGND, DGND, V_{CC}, V_{EE}, and V_{LL}
- θ_{JA}, Thermal Impedance 50°C/W
- Junction Temperature 175°C
- Storage Temperature -65°C to +150°C
- Lead Temperature (Soldering, 10 sec) +300°C

*Stresses above those listed under “Absolute Maximum Ratings” may cause permanent damage to the device. This is a stress rating only and functional operation of the device at these or any other conditions above those indicated in the operational section of this specification is not implied. Exposure to absolute maximum rating conditions for extended periods may affect device reliability.

PIN CONFIGURATION

DIP

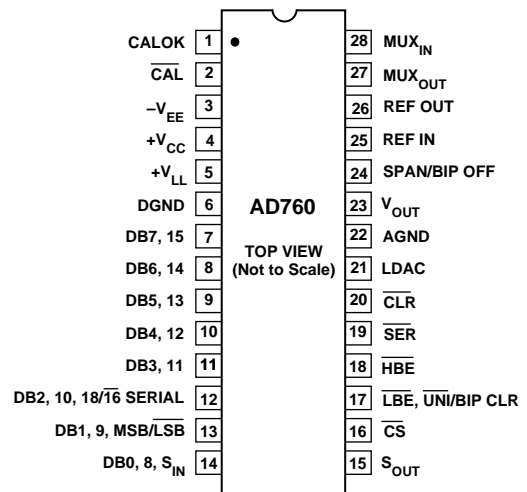

ORDERING GUIDE

Model	Temperature Range	Package Description	Package Option
AD760AQ	-40°C to +85°C	Cerdip	Q-28

CAUTION

ESD (electrostatic discharge) sensitive device. Electrostatic charges as high as 4000 V readily accumulate on the human body and test equipment and can discharge without detection. Although the AD760 features proprietary ESD protection circuitry, permanent damage may occur on devices subjected to high energy electrostatic discharges. Therefore, proper ESD precautions are recommended to avoid performance degradation or loss of functionality.



AD760

DEFINITIONS OF SPECIFICATIONS

INTEGRAL NONLINEARITY: Analog Devices defines integral nonlinearity as the maximum deviation of the actual, adjusted DAC output from the ideal analog output (a straight line drawn from 0 to FS - 1 LSB) for any bit combination. This is also referred to as relative accuracy.

DIFFERENTIAL NONLINEARITY: Differential nonlinearity is the measure of the change in the analog output, normalized to full scale, associated with a 1 LSB change in the digital input code. Monotonic behavior requires that the differential linearity error be greater than or equal to -1 LSB over the temperature range of interest.

MONOTONICITY: A DAC is monotonic if the output either increases or remains constant for increasing digital inputs with the result that the output will always be a single-valued function of the input.

GAIN ERROR: Gain error is a measure of the output error between an ideal DAC and the actual device output with all 1s loaded after offset error has been adjusted out.

OFFSET ERROR: Offset error is a combination of the offset errors of the voltage-mode DAC and the output amplifier and is measured with all 0s loaded in the DAC.

BIPOLAR ZERO ERROR: When the AD760 is connected for bipolar output and 10 . . . 000 is loaded in the DAC, the deviation of the analog output from the ideal midscale value of 0 V is called the bipolar zero error.

DRIFT: Drift is the change in a parameter (such as gain, offset and bipolar zero) over a specified temperature range. The drift temperature coefficient, specified in ppm/°C, is calculated by measuring the parameter at T_{MIN} , 25°C and T_{MAX} and dividing the change in the parameter by the corresponding temperature change.

TOTAL HARMONIC DISTORTION + NOISE: Total harmonic distortion + noise (THD+N) is defined as the ratio of the square root of the sum of the squares of the values of the harmonics and noise to the value of the fundamental input frequency. It is usually expressed in percent (%). THD+N is a measure of the magnitude and distribution of linearity error, differential linearity error, quantization error and noise. The distribution of these errors may be different, depending upon the amplitude of the output signal. Therefore, to be the most useful, THD+N should be specified for both large and small signal amplitudes.

SIGNAL-TO-NOISE RATIO: The signal-to-noise ratio is defined as the ratio of the amplitude of the output when a full-scale signal is present to the output with no signal present. This is measured in dB.

DIGITAL-TO-ANALOG GLITCH IMPULSE: This is the amount of charge injected from the digital inputs to the analog output when the inputs change state. This is measured at half scale when the DAC switches around the MSB and as many as possible switches change state, i.e., from 011 . . . 111 to 100 . . . 000.

DIGITAL FEEDTHROUGH: When the DAC is not selected (i.e., \overline{CS} is held high), high frequency logic activity on the digital inputs is capacitively coupled through the device to show up as noise on the V_{OUT} pin. This noise is digital feedthrough.

THEORY OF OPERATION

The AD760 uses autocalibration circuitry to produce a true 16-bit DAC with typically 0.2 LSB Integral and Differential Linearity Error and 0.5 LSB Offset Error. The block diagram in Figure 2 shows the circuit components needed for calibration.

The MAIN DAC uses an array of bipolar current sources with MOS current steering switches to develop a current proportional to the applied digital word, ranging from 0 mA to 2 mA. A segmented architecture is used, where the most significant four data bits are thermometer decoded to drive 15 equal current sources. The lesser bits are scaled using an R-2R ladder, then applied together with the segmented sources to the summing node of the output amplifier. An extra LSB is included in the MAIN DAC, for use during calibration.

The self-calibration architecture of the AD760 attempts to reduce the linearity errors of its transfer function. The algorithm first checks for bipolar or unipolar operation, calibrates either bipolar zero or unipolar offset, and then removes the carry errors (DNL errors) associated with the upper 6 bits (64 codes).

Once calibrated, the top six bits of a code entering the MAIN DAC simultaneously address the RAM, calling up a correction code that is then applied to the CALDAC. The output currents of both the MAIN DAC and CALDAC are combined in the summing amplifier to produce the corrected output voltage.

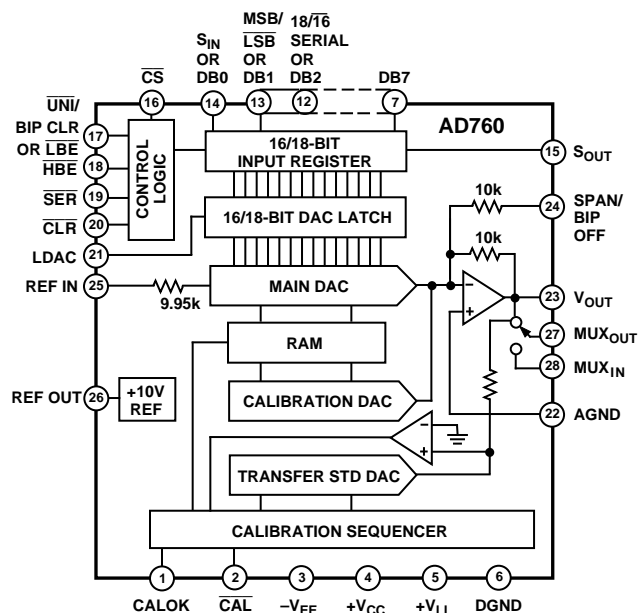

Figure 2. Functional Block Diagram

In the first step of DNL calibration the output of the MAIN DAC is set to the code just below the code to be calibrated. The extra LSB in the MAIN DAC is turned on to find the extrapolated value for the next code. The comparator is then nulled using TRANSFER STD DAC. The voltage at V_{OUT} has in effect been sampled at the code to be calibrated.

Next, the extra LSB is turned off and the MAIN DAC code is incremented by one LSB. The comparator is once again nulled, this time with the CALDAC, until the V_{OUT} is adjusted to equal the previously sampled output. The CALDAC code is stored in RAM and the process is repeated for the next code.

CALIBRATED LINEARITY PERFORMANCE

The cumulative probability plots for the AD760 INL and DNL shown in Figures 3 and 4 represent the maximum absolute-value (peak) linearity error for each part. Roughly 100 parts from each of 3 wafer lots were used.

The calibrated DNL and INL performance for the sample populations shown also represent the expected performance for a single part calibrated often. There is essentially no difference between the expected performance of many parts calibrated once and one part calibrated often. The AD760 calibrated performance is guaranteed at any temperature within the operating temperature range. The peak nonlinearity for the sample populations shown are also representative of the expected maximum linearity errors of a single part recalibrated at temperature.

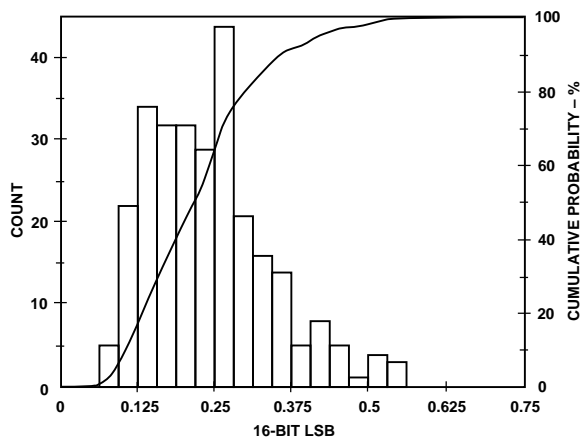

Figure 3. AD760 Peak INL

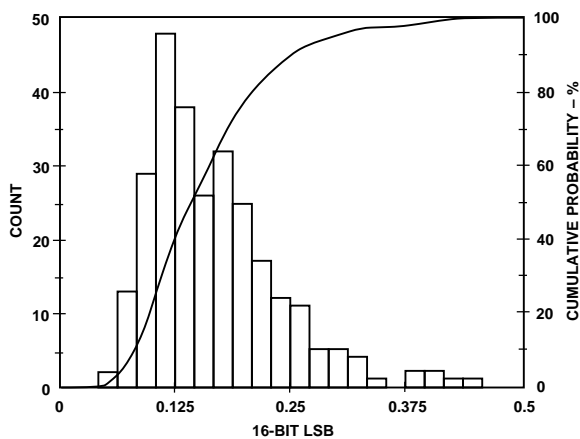

Figure 4. AD760 Peak DNL

ANALOG CIRCUIT CONNECTIONS

Internal scaling resistors provided in the AD760 may be connected to produce a unipolar output range of 0 V to +10 V or a bipolar output range of -10 V to +10 V. Gain and offset drift are minimized in the AD760 because of the thermal tracking of the scaling resistors with other device components.

UNIPOLAR CONFIGURATION

The configuration shown in Figure 5a will provide a unipolar 0 V to +10 V output range. In this mode a 50 Ω resistor is tied between REF OUT (Pin 26) and REF IN (Pin 25). It is possible to use the AD760 without any external components by tying Pin 26 directly to Pin 25. Eliminating this resistor will increase the gain error by 0.50% of FSR.

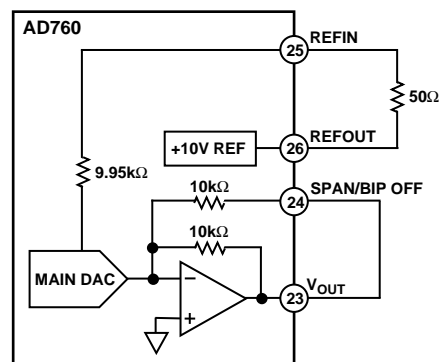

Figure 5a. 0 V to +10 V Unipolar Voltage Output

If it is desired to adjust the gain error to zero, this can be accomplished using the circuit shown in Figure 5b. The adjustment procedure is as follows:

STEP 1 . . . OFFSET ADJUST

Initiate calibration sequence. CALOK (Pin 1) must remain high throughout Gain Adjust.

STEP 2 . . . GAIN ADJUST

Turn all bits ON and adjust gain trimmer, R1, until the output is 9.999847 volts. (Full scale is adjusted to 1 LSB less than the nominal full scale of 10.000000 volts.)

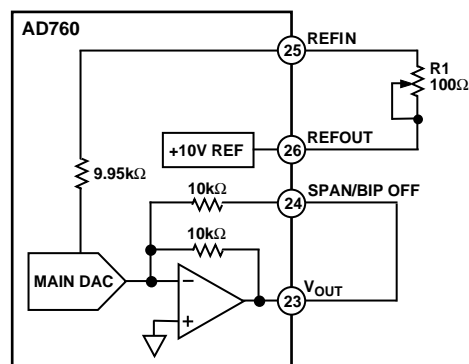

Figure 5b. 0 V to +10 V Unipolar Voltage Output with Gain Adjust

BIPOLAR CONFIGURATION

The circuit shown in Figure 6a will provide a bipolar output voltage from -10.000000 V to +9.999694 V with positive full scale occurring with all bits ON. As in the unipolar mode, resistor R1 may be eliminated altogether to provide AD760 bipolar operation without any external components. Eliminating this resistor will increase the gain error by 0.50% of FSR in the bipolar mode.

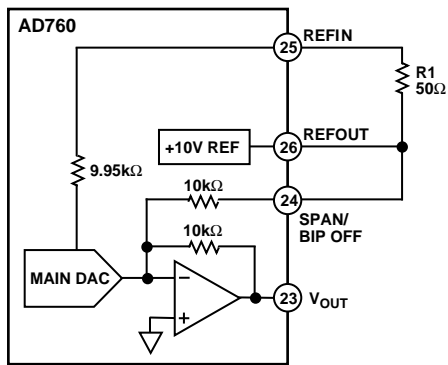

Figure 6a. 0 V to ±10 V Bipolar Voltage Output

Gain Error can be adjusted to zero using the circuit shown in Figure 6b. Note that gain adjustment changes the Bipolar Zero by one half of the variation made to the full-scale output value. Therefore, to eliminate iterating between Zero (calibration) and Gain adjustment the following procedure is recommended.

STEP 1 . . . ZERO ADJUST

Initiate Calibration Sequence.

STEP 2 . . . GAIN ADJUST

Insure the CALOK pin remains high throughout the gain adjustment process. Turn all bits on and measure the output error relative to the full-scale output of 9.99695 V. Adjust R1 until the output is minus two times the full-scale output error. For example, if the output error is -1 mV, adjust the output 2 mV higher than the previous full-scale error.

STEP 3 . . . ZERO ADJUST

Initiate Calibration Sequence. The AD760 will calibrate Bipolar Zero and the resulting Gain Error will be very small. Reload the DAC with all ones to check the full-scale output error.

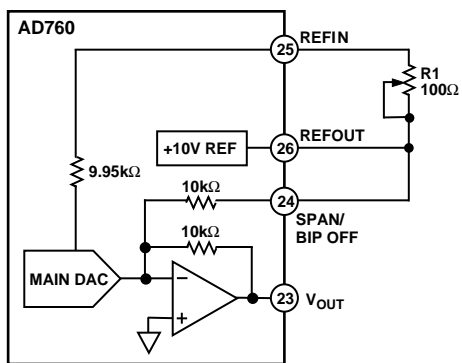

Figure 6b. 0 V to ±10 V Bipolar Voltage Output Gain Adjustment

It should be noted that using external resistors will introduce a small temperature drift component beyond that inherent in the AD760. The internal resistors are trimmed to ratio-match and temperature-track other resistors on chip, even though their absolute tolerances are ±20% and absolute temperature coefficients are approximately -50 ppm/°C. In the case that external resistors are used, the temperature coefficient mismatch between internal and external resistors, multiplied by the sensitivity of the circuit to variations in the external resistor value, will be the resultant additional temperature drift.

INTERNAL/EXTERNAL REFERENCE USE

The AD760 has an internal low noise buried Zener diode reference that is trimmed for absolute accuracy and temperature coefficient. This reference is buffered and optimized for use in a high speed DAC and will give long-term stability equal or superior to the best discrete Zener diode references. The performance of the AD760 is specified with the internal reference driving the DAC and with the DAC alone (for use with a precision external reference).

The internal reference has sufficient buffering to drive external circuitry in addition to the reference currents required for the DAC (typically 1 mA to REF IN and 1 mA to BIPOLAR OFF-SET). A minimum of 2 mA is available for driving external loads. The AD760 reference output should be buffered with an external op amp if it is required to supply more than 4 mA total current. The reference is tested and guaranteed to ±0.1% max error.

It is also possible to use external references other than 10 volts with slightly degraded linearity specifications. The recommended range of reference voltages is +5 V to +10.24 V. For example, by using the AD586 5 V reference, outputs of 0 V to +5 V or ±5 V can be realized. Using the AD586 voltage reference makes it possible to operate the AD760 with ±12 V supplies with 10% tolerances.

Figure 7 shows the AD760 using the AD586 precision 5 V reference in the bipolar configuration. The highest grade AD586MN is specified with a drift of 2 ppm/°C. This circuit includes an optional potentiometer that can be used to adjust the gain error in a manner similar to that described in the Bipolar Configuration section. Use +4.999847 V as the full-scale output value.

The AD760 can also be used with the AD587, 10 V reference, using the same configuration shown in Figure 7 to produce a ±10 V output. The highest grade AD587L is specified at 5 ppm/°C.

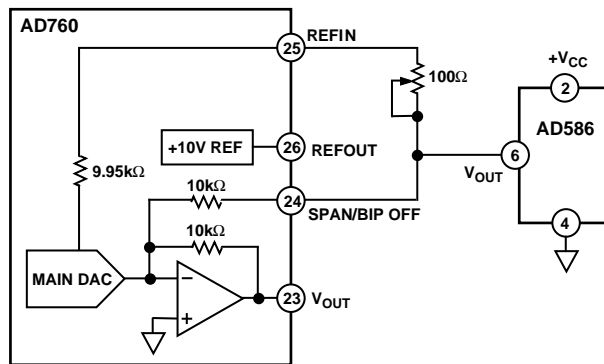
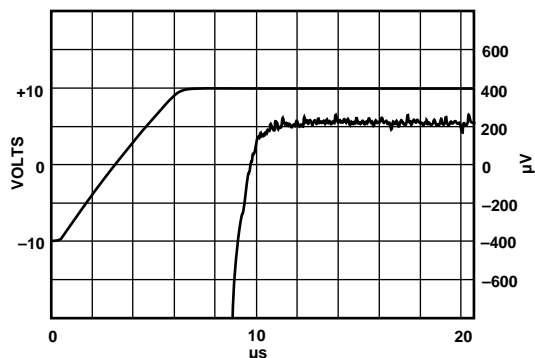

Figure 7. Using the AD760 with the AD586 5 V Reference

OUTPUT SETTLING AND GLITCH

The AD760's output buffer amplifier typically settles to within 0.0008% FS (1/2 LSB) of its final value in 8 μs for a full-scale step. Figures 8a and 8b show settling for a full scale and an LSB step, respectively, with a 2 k Ω , 1000 pF load applied. The guaranteed maximum settling time at +25°C for a full-scale step is 13 μs with this load. The typical settling time for a 1 LSB step is 2.5 μs.

The digital-to-analog glitch impulse is specified as 15 nV-s typical. Figure 8c shows the typical glitch impulse characteristic at the code 011 . . . 111 to 100 . . . 000 transition when loading the second rank register from the first rank register.



a. $-10\text{ V to }+10\text{ V Full-Scale Step Settling}$

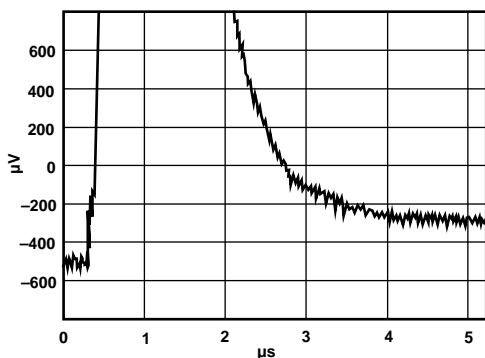

b. LSB Step Settling

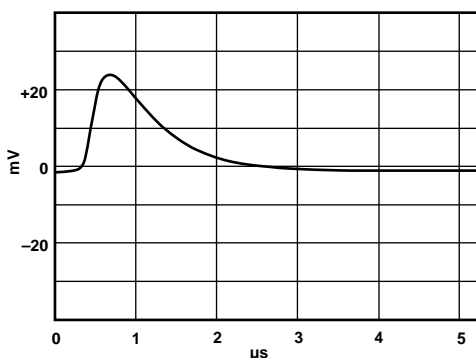

c. $\text{D-to-A Glitch Impulse}$

Figure 8. Output Characteristics

DIGITAL CIRCUIT DETAILS

The AD760 has several “dual-use” pins that allow flexible operation while maintaining the lowest possible pin count and consequently the smallest package size. The following information is useful when applying the AD760.

The AD760 uses an internal **Output Multiplexer** to disconnect the DAC output from MUX_{OUT} (Pin 27) when the device is uncalibrated or when a calibration sequence is in progress. At those times MUX_{OUT} is switched to MUX_{IN} (Pin 28) so the user can force a predetermined output voltage. Refer to the following section for using the output multiplexer.

A **Power-On-Reset** feature senses whenever any power supply is low enough to jeopardize the integrity of the calibration data in the RAM. At power-up or in the event of a power supply transient, CALOK (Pin 1) is low and the MUX_{OUT} pin is switched to MUX_{IN} .

Self-Calibration is initiated by strobing the $\overline{\text{CAL}}$ pin low (refer to Figure 1d). The CALOK pin will go low and the MUX_{OUT} pin is connected to MUX_{IN} . During calibration, the second-rank latch is transparent to allow the **CALIBRATION SEQUENCER** to control the **MAIN DAC**. After successful completion of calibration, the input to the second-rank latch is switched to the first-rank latch, the DAC is loaded with the contents of the first-rank latch, V_{OUT} settles to the value represented by the data in the first-rank latch, then CALOK will go high, and MUX_{OUT} is switched to V_{OUT} . Therefore the user should program the DAC with the desired data before initiating the calibration. The second rank latch, controlled by LDAC , is a transparent latch. As long as LDAC remains high, changes in the first rank latch will be reflected in the DAC output immediately.

The status of the calibration may be determined by taking the $\overline{\text{HBE}}$ pin low. CALOK either switches high if the calibration is in progress, or CALOK remains low if a power supply voltage transient has interrupted the calibration and caused the AD760 to be set to the uncalibrated state.

When $\overline{\text{CLR}}$ is strobed, Pin 17 functions as a control input, $\overline{\text{UNI/BIP CLR}}$, that determines how the **Asynchronous Clear** function works (refer to Figure 1c). If the $\overline{\text{UNI/BIP CLR}}$ pin is a logic low when $\overline{\text{CLR}}$ is strobed the DAC is set to minus full-scale; a logic high sets the DAC to midscale. It should be noted that the clear function clears the DAC Latch but does not clear the first rank latch. Therefore, the data that remains in the first rank latch can be reloaded by simply bringing LDAC high again. Alternately, new data can be loaded into the first rank latch if desired.

Serial Mode Operation is enabled by bringing the $\overline{\text{SER}}$ (Pin 19) low. This changes the function of DB0 (Pin 14) to that of the serial input pin, SIN . The function of DB1 (Pin 13) also changes to a control input, $\text{MSB}/\overline{\text{LSB}}$ that determines which bit is to be loaded first.

Sixteen or Eighteen-Bit Operation is selected with another dual use pin. DB2 (Pin 12) changes to a control input, $18/16\text{-SERIAL}$, that selects whether 16-bit or 18-bit serial data is to be used. For 16-bit operation the data inputs, Pins 7–12, should be tied low. For 18-bit operation Pin 12 must be tied high.

Data is clocked into the input shift register on the rising edge of $\overline{\text{CS}}$ as shown in Figure 1b. The data is then resident in the first rank latch and can be loaded into the DAC by taking the LDAC pin high. This will cause the DAC to change to the appropriate output value. In serial mode the byte controls $\overline{\text{HBE}}$ (Pin 18) and $\overline{\text{LBE}}$ (Pin 17) are disabled. Pin 17 can be tied to a logic high or low depending on how the user wants the asynchronous clear function to work. The **Serial Out** pin (S_{OUT}) can be used to daisy chain several DACs together in multi-DAC applications to minimize the number of control lines required. The first rank latch simply acts as a shift register, and repeated strobing of $\overline{\text{CS}}$ will shift the data out through S_{OUT} and into the next DAC. Each DAC in the chain will require its own LDAC signal unless all of the DACs are to be updated simultaneously.

AD760

Byte Mode Operation is enabled by setting $\overline{\text{SER}}$ high, which configures DB0–DB7 as data inputs. In this mode $\overline{\text{HBE}}$ and $\overline{\text{LBE}}$ are used to identify the data as either the high byte or the low byte of the 16-bit word. The user can load the data in either order into the first rank latch using the rising edge of the $\overline{\text{CS}}$ signal as shown in Figure 1a. The status of Pin 17 when $\overline{\text{CLR}}$ is strobed determines whether the AD760 clears to unipolar or bipolar zero. (But it cannot be hardwired to the desired state, as in the serial mode.)

NOTE: $\overline{\text{CS}}$ is edge triggered. $\overline{\text{HBE}}$, $\overline{\text{LBE}}$, $\overline{\text{CLR}}$, $\overline{\text{SER}}$, $\overline{\text{CAL}}$, and LDAC are level triggered.

USING THE OUTPUT MULTIPLEXER

The onboard multiplexer allows the user to isolate the load from the voltage variations at V_{OUT} during calibration. To minimize the glitch-impulse at MUX_{OUT} , the multiplexer input, MUX_{IN} , should be tied to a voltage equal to the DAC's negative full-scale voltage. Since the DAC is loaded with the contents of its first-rank latch before completing calibration, the DAC should be programmed to negative full scale before calibrating. This will minimize the voltage excursions of MUX_{OUT} at the beginning and end of calibration. If the glitch-impulse at the beginning of calibration is not important, yet the user wants to minimize the recovery time at MUX_{OUT} , MUX_{IN} should be set to the voltage that corresponds to the data in the first-rank latch before calibration is initiated.

The multiplexer series on-resistance limits its load-drive capability. To attain 16-bit linearity, MUX_{OUT} must be buffered with a suitable op amp. The amplifier open loop-gain and common-mode rejection contribute to gain error whereas the linearity of these parameters affect the relative accuracy (or integral nonlinearity). In general, the amplifier linearity is not specified so its effects must be determined empirically. Using the AD707, as shown in Figure 9, the overall linearity error is within 0.5 LSB. The AD707C/T initial voltage offset and its temperature coefficient will not contribute more than 0.1 LSB to the Bipolar Zero Error over the entire operating temperature range. The settling time to 1/2 LSB is typically 100 μs for a 20 V step. For applications that require faster settling, the AD820 can be used to attain full-scale settling to within a 1/2 LSB in 20 μs . The additional linearity error from the AD820 will be no more than 0.25 LSB.

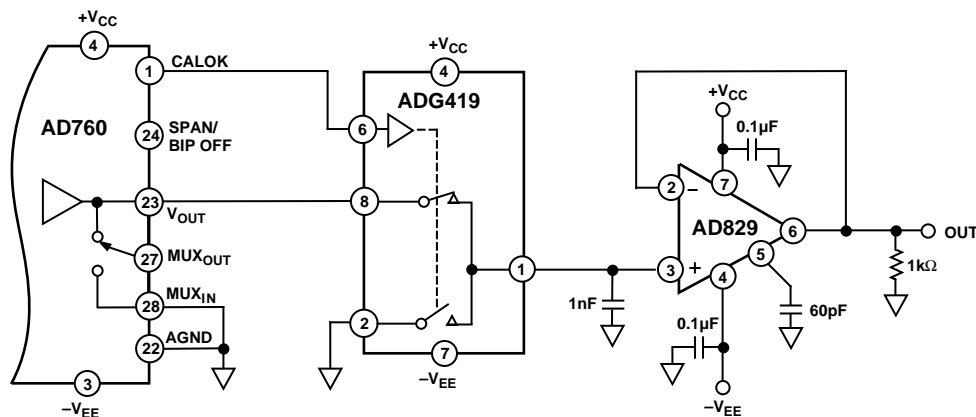

Figure 10. Using the AD760 with an External MUX

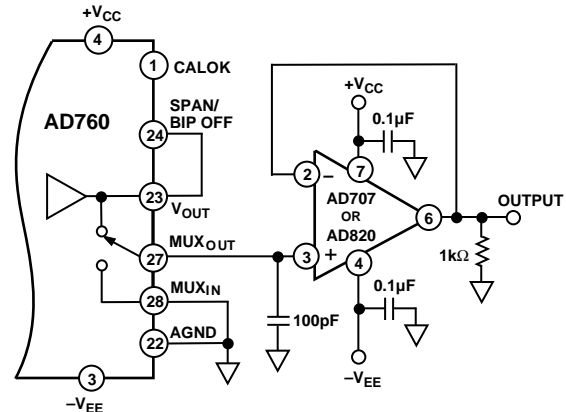

Figure 9. Buffering the AD760 Internal MUX

USING AN EXTERNAL MULTIPLEXER

An external multiplexer like the ADG419 allows the user to minimize the glitch impulse when holding the output to any predetermined voltage during calibration. The ADG419 can be used with a high speed op amp like the AD829, as shown in Figure 10, to attain the fastest possible settling time while maintaining 16-bit linearity. The settling time to 1/2 LSB for a 20 V step is typically 10 μs .

AD760 TO MC68HC11 (SPI* BUS) INTERFACE

The AD760 interface to the Motorola SPI (serial peripheral interface) is shown in Figure 11. The MOSI, SCK, and $\overline{\text{SS}}$ pins of the HC11 are respectively connected to the S_{IN} , $\overline{\text{CS}}$ and LDAC pins of the AD760. The majority of the interfacing issues are taken care of in the software initialization. A typical routine such as the one shown below begins by initializing the state of the various SPI data and control registers.

The most significant data byte (MSBY) is then retrieved from memory and processed by the SENDAT subroutine. The $\overline{\text{SS}}$ pin is driven low by indexing into the PORTD data register and clearing Bit 5. The MSBY is then sent to the SPI data register where it is automatically transferred to the AD760.

*SPI is a registered trademark of Motorola.

The HC11 generates the requisite 8 clock pulses with data valid on the rising edges. After the most significant byte is transmitted, the least significant byte (LSBY) is loaded from memory and transmitted in a similar fashion. To complete the transfer, the LDAC pin is driven high latching the complete 16-bit word into the AD760.

```

INIT   LDAA  #$2F    ;SS = 1; SCK = 0; MOSI = 1
       STAA  PORTD  ;SEND TO SPI OUTPUTS
       LDAA  #$38    ;SS, SCK, MOSI = OUTPUTS
       STAA  DDRD   ;SEND DATA DIRECTION INFO
       LDAA  #$50    ;DABL INTRPTS, SPI IS MASTER & ON
       STAA  SPCR   ;CPOL=0, CPHA=0, 1MHZ BAUD RATE

NEXTPT LDAA  MSBY   ;LOAD ACCUM W/UPPER 8 BITS
       BSR   SENDAT ;JUMP TO DAC OUTPUT ROUTINE
       JMP  NEXTPT  ;INFINITE LOOP

SENDAT LDY   #$1000 ;POINT AT ON-CHIP REGISTERS
       BCLR  $08,Y,$20 ;DRIVE SS (LDAC) LOW
       STAA  SPDR   ;SEND MS-BYTE TO SPI DATA REG

WAIT1  LDAA  SPSR   ;CHECK STATUS OF SPIE
       BPL  WAIT1  ;POLL FOR END OF X-MISSION
       LDAA  LSBY   ;GET LOW 8 BITS FROM MEMORY
       STAA  SPDR   ;SEND LS-BYTE TO SPI DATA REG

WAIT2  LDAA  SPSR   ;CHECK STATUS OF SPIE
       BPL  WAIT2  ;POLL FOR END OF X-MISSION
       BSET  $08,Y,$20 ;DRIV SS HIGH TO LATCH DATA
       RTS

```

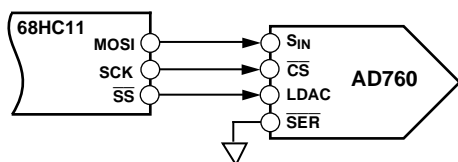

Figure 11. AD760 to 68HC11 (SPI) Interface

AD760 TO MICROWIRE INTERFACE

The flexible serial interface of the AD760 is also compatible with the National Semiconductor MICROWIRE* interface. The MICROWIRE* interface is used on microcontrollers such as the COP400 and COP800 series of processors. A generic interface to the MICROWIRE interface is shown in Figure 12. The G1, SK, and SO pins of the MICROWIRE interface are respectively connected to the LDAC, CS and S_{IN} pins of the AD760.

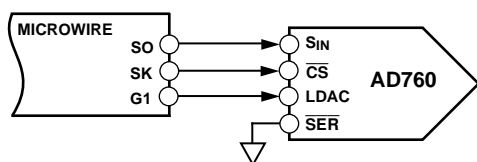

Figure 12. AD760 to MICROWIRE Interface

NOISE

In high resolution systems, noise is often the limiting factor. A 16-bit DAC with a 10 volt span has an LSB size of 153 μ V (-96 dB). Therefore, the noise must remain below this level in

*MICROWIRE is a registered trademark of National Semiconductor.

the frequency range of interest. The AD760's noise spectral density is shown in Figures 13 and 14. Figure 13 shows the DAC output noise voltage spectral density for a 20 V span excluding the reference. This figure shows the 1/f corner frequency at 100 Hz and the wideband noise to be below 120 nV/ $\sqrt{\text{Hz}}$. Figure 14 shows the reference wideband noise to be below 125 nV/ $\sqrt{\text{Hz}}$.

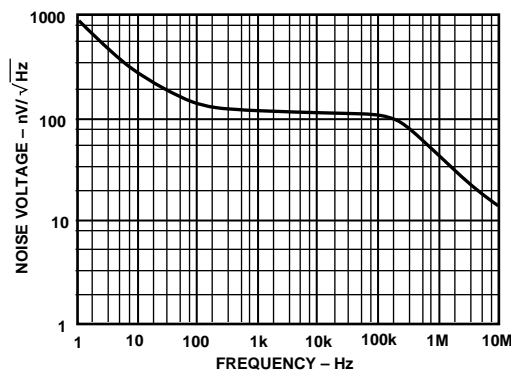

Figure 13. DAC Output Noise Voltage Spectral Density

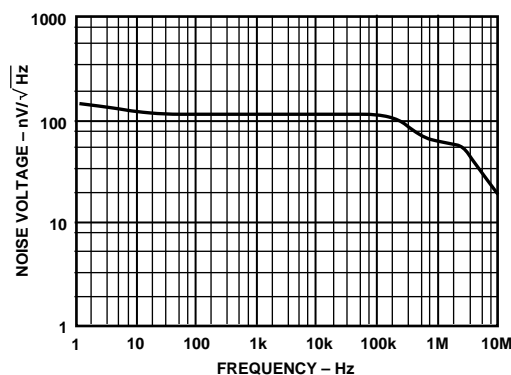

Figure 14. Reference Noise Voltage Spectral Density

BOARD LAYOUT

Designing with high resolution data converters requires careful attention to board layout. Trace impedance is the first issue. A 306 μ A current through a 0.5 trace will develop a voltage drop of 153 μ V, which is 1 LSB at the 16-bit level for a 10 V full-scale span. In addition to ground drops, inductive and capacitive coupling need to be considered, especially when high accuracy analog signals share the same board with digital signals. Finally, power supplies need to be decoupled in order to filter out ac noise.

Analog and digital signals should not share a common path. Each signal should have an appropriate analog or digital return routed close to it. Using this approach, signal loops enclose a small area, minimizing the inductive coupling of noise. Wide PC tracks, large gauge wire, and ground planes are highly recommended to provide low impedance signal paths. Separate analog and digital ground planes should also be used, with a single interconnection point to minimize ground loops. Analog signals should be routed as far as possible from digital signals and should cross them at right angles.

AD760

One feature that the AD760 incorporates to help the user layout is that the analog pins (V_{CC} , V_{EE} , REF OUT, REF IN, SPAN/BIP OFFSET, V_{OUT} , MUX_{OUT}, MUX_{IN} and AGND) are adjacent to help isolate analog signals from digital signals.

SUPPLY DECOUPLING

The AD760 power supplies should be well filtered, well regulated, and free from high frequency noise. Switching power supplies are not recommended due to their tendency to generate spikes which can induce noise in the analog system.

Decoupling capacitors should be used in very close layout proximity between all power supply pins and ground. A 10 μF tantalum capacitor in parallel with a 0.1 μF ceramic capacitor provides adequate decoupling. V_{CC} and V_{EE} should be bypassed to analog ground, while V_{LL} should be decoupled to digital ground.

An effort should be made to minimize the trace length between the capacitor leads and the respective converter power supply and common pins. The circuit layout should attempt to locate the AD760, associated analog circuitry and interconnections as far as possible from logic circuitry. A solid analog ground plane around the AD760 will isolate large switching ground currents. For these reasons, the use of wire wrap circuit construction is not recommended; careful printed circuit construction is preferred.

GROUNDING

The AD760 has two pins, designated analog ground (AGND) and digital ground (DGND.) The analog ground pin is the "high quality" ground reference point for the device. Any external loads on the output of the AD760 should be returned to analog ground. If an external reference is used, this should also be returned to the analog ground.

If a single AD760 is used with separate analog and digital ground planes, connect the analog ground plane to AGND and the digital ground plane to DGND keeping lead lengths as short as possible. Then connect AGND and DGND together at the AD760. If multiple AD760s are used or the AD760 shares analog supplies with other components, connect the analog and digital returns together once at the power supplies rather than at each chip. This single interconnection of grounds prevents large ground loops and consequently prevents digital currents from flowing through the analog ground.

PACKAGE INFORMATION

28-Pin Cerdip Package (Q-28)

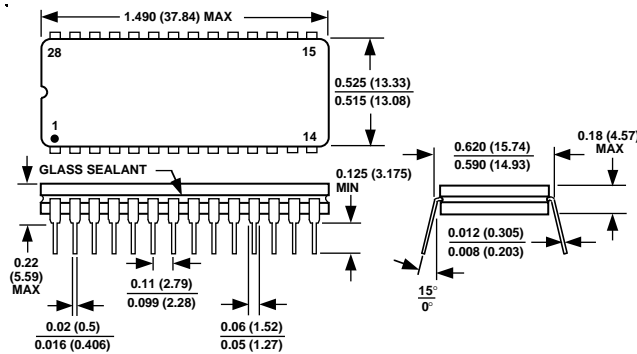



LittleDiode supplies new, hard to find or obsolete electronic components and semiconductors all over the world.

With over two million different components listed you are sure to find the part you need.

Feel free to visit us today at our online store:

LittleDiode.com

Looking forward to providing you with the best possible service.