

FEATURES

- 16-Bit Sigma-Delta ADC**
- 64× Oversampling Ratio**
- Up to 220 kSPS Output Word Rate**
- Low-Pass, Linear Phase Digital Filter**
- Inherently Monotonic**
- On-Chip 2.5 V Voltage Reference**
- Single Supply +5 V**
- High Speed Parallel or Serial Interface**

GENERAL DESCRIPTION

The AD7722 is a complete low power, 16-bit, sigma-delta ADC. The part operates from a +5 V supply and accepts a differential input voltage range of 0 V to +2.5 V or ± 1.25 V centered around a common-mode bias. The AD7722 provides 16-bit performance for input bandwidths up to 90.625 kHz. The part provides data at an output word rate of 195.3 kHz.

The analog input is continuously sampled by an analog modulator eliminating the need for external sample-and-hold circuitry. The modulator output is processed by two Finite Impulse Response (FIR) digital filters in series. The on-chip filtering reduces the external antialias requirements to first order, in most cases. The group delay for the filter is 215.5 μ s, while the settling time for a step input is 431 μ s. The sample rate, filter corner frequency, and output word rate are set by an external clock that is nominally 12.5 MHz.

Use of a single bit DAC in the modulator guarantees excellent linearity and dc accuracy. Endpoint accuracy is ensured by on-chip calibration. This calibration procedure minimizes the zero-scale and full-scale errors.

FUNCTIONAL BLOCK DIAGRAM

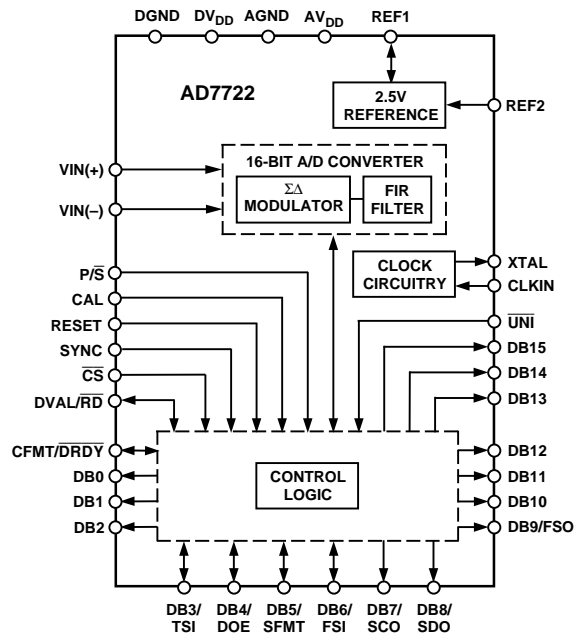

Conversion data is provided at the output register through a flexible serial port or a parallel port. This offers 3-wire, high speed interfacing to digital signal processors. The serial interface operates in an internal clocking (master) mode, whereby an internal serial data clock and framing pulse are device outputs. Additionally, two AD7722s can be configured with the serial data outputs connected together. Each converter alternately transmits its conversion data on a shared serial data line.

The part provides an accurate on-chip 2.5 V reference. A reference input/output function is provided to allow either the internal reference or an external system reference to be used as the reference source for the part.

The AD7722 is available in a 44-pin PQFP package and is specified over the industrial temperature range from -40°C to $+85^{\circ}\text{C}$.

REV. 0

Information furnished by Analog Devices is believed to be accurate and reliable. However, no responsibility is assumed by Analog Devices for its use, nor for any infringements of patents or other rights of third parties which may result from its use. No license is granted by implication or otherwise under any patent or patent rights of Analog Devices.

AD7722—SPECIFICATIONS¹

($AV_{DD} = AV_{DD1} = +5\text{ V} \pm 5\%$; $DV_{DD} = +5\text{ V} \pm 5\%$; $AGND = AGND1 = DGND = 0\text{ V}$;
 $\overline{UNI} = \text{Logic Low or High}$; $f_{CLKIN} = 12.5\text{ MHz}$; $F_S = 195.3\text{ kSPS}$; $REF2 = +2.5\text{ V}$; $T_A = T_{MIN}$ to T_{MAX} ; unless otherwise noted)

Parameter	Test Conditions/Comments	Min	A Version Typ	Max	Units
DYNAMIC SPECIFICATIONS²					
Bipolar Mode, $\overline{UNI} = V_{INH}$	$V_{CM} = 2.5\text{ V}$, $V_{IN(+)} = V_{IN(-)} = 1.25\text{ V}$ pk-pk or, $V_{IN(-)} = 1.25\text{ V}$, $V_{IN(+)} = 0$ to 2.5				
Signal to (Noise + Distortion) ³	Input Bandwidth 0 kHz–90.625 kHz	86/84.5	90		dB
Total Harmonic Distortion ³	Input Bandwidth 0 kHz–100 kHz, $f_{CLKIN} = 14\text{ MHz}$	84.5/83			dB
Spurious Free Dynamic Range	Input Bandwidth 0 kHz–90.625 kHz			–90/–88	dB
	Input Bandwidth 0 kHz–100 kHz, $f_{CLKIN} = 14\text{ MHz}$			–88/–86	dB
	Input Bandwidth 0 kHz–90.625 kHz			–90	dB
Unipolar Mode, $\overline{UNI} = V_{INL}$	$V_{IN(-)} = 0\text{ V}$, $V_{IN(+)} = 0$ to 2.5				
Signal to (Noise + Distortion) ³	Input Bandwidth 0 kHz–90.625 kHz	84.5/83	88		dB
Total Harmonic Distortion ³	Input Bandwidth 0 kHz–97.65 kHz			–89/–87	dB
Spurious Free Dynamic Range	Input Bandwidth 0 kHz–97.65 kHz			–90	dB
Intermodulation Distortion			–93		dB
AC CMRR	$V_{IN(+)} = V_{IN(-)} = 2.5\text{ V}$ pk-pk $V_{CM} = 1.25\text{ V}$ to 3.75 V , 20 kHz		96		dB
Digital Filter Response					
Pass-Band Ripple	0 kHz–90.625 kHz			± 0.005	dB
Cutoff Frequency		96.92			kHz
Stop-Band Attenuation	104.6875 kHz to 12.395 MHz		90		dB
ANALOG INPUTS					
Full-Scale Input Span	$V_{IN(+)} - V_{IN(-)}$				V
Bipolar Mode	$\overline{UNI} = V_{INH}$	$-V_{REF2}/2$		$+V_{REF2}/2$	V
Unipolar Mode	$\overline{UNI} = V_{INL}$	0		V_{REF2}	V
Absolute Input Voltage	$V_{IN(+)}$ and $V_{IN(-)}$	0		AV_{DD}	V
Input Sampling Capacitance			2		pF
Input Sampling Rate	Guaranteed by Design		$2 \times f_{CLKIN}$		Hz
Differential Input Impedance			$1/8E-09 \times f_{CLKIN}$		k Ω
CLOCK					
CLKIN Mark Space Ratio		45		55	%
REFERENCE					
REF1 Output Voltage		2.32	2.47	2.62	V
REF1 Output Voltage Drift			60		ppm/ $^{\circ}\text{C}$
REF1 Output Impedance			3		k Ω
Reference Buffer					
Offset Voltage	Offset Between REF1 and REF2			± 12	mV
Using Internal Reference					
REF2 Output Voltage		2.32	2.47	2.62	V
REF2 Output Voltage Drift			60		ppm/ $^{\circ}\text{C}$
Using External Reference					
REF2 Input Impedance	REF1 = AGND		$1/16E-09 \times f_{CLKIN}$		k Ω
External Reference Voltage Range	Applied to REF1 or REF2	2.32	2.5	2.62	V
STATIC PERFORMANCE					
Resolution		16			Bits
Differential Nonlinearity	Guaranteed Monotonic		± 0.5	± 1	LSB
Integral Nonlinearity			± 2		LSB
After Calibration					
Offset Error ⁴				± 3	mV
Gain Error ^{4, 5}				± 0.6	% FSR
Without Calibration					
Offset Error			± 6		mV
Gain Error ⁵			± 0.6		% FSR
Offset Error Drift			± 1		LSB/ $^{\circ}\text{C}$
Gain Error Drift	REF2 Is an Ideal Reference, REF1 = AGND				
	Unipolar Mode		± 1		LSB/ $^{\circ}\text{C}$
	Bipolar Mode		± 0.5		LSB/ $^{\circ}\text{C}$

Parameter	Test Conditions/Comments	Min	A Version Typ	Max	Units
LOGIC INPUTS (Excluding CLKIN) V_{INH} , Input High Voltage V_{INL} , Input Low Voltage		2.0		0.8	V V
CLOCK INPUT (CLKIN) V_{INH} , Input High Voltage V_{INL} , Input Low Voltage		4.0		0.4	V V
ALL LOGIC INPUTS I_{IN} , Input Current C_{IN} , Input Capacitance	$V_{IN} = 0 \text{ V to } DV_{DD}$			± 10 10	μA pF
LOGIC OUTPUTS V_{OH} , Output High Voltage V_{OL} , Output Low Voltage	$ I_{OUT} = 200 \mu\text{A}$ $ I_{OUT} = 1.6 \text{ mA}$	4.0		0.4	V V
POWER SUPPLIES AV_{DD} , AV_{DD1} DV_{DD} I_{DD} Power Consumption	Total from AV_{DD} and DV_{DD}	4.75 4.75		5.25 5.25 75 375	V V mA mW

NOTES

¹Operating temperature range is as follows : A Version ; -40°C to $+85^{\circ}\text{C}$.

²Measurement Bandwidth = $0.5 \times F_S$; Input Level = -0.05 dB .

³ $T_A = +25^{\circ}\text{C}$ to $+85^{\circ}\text{C}/T_A = T_{MIN}$ to T_{MAX} .

⁴Applies after calibration at temperature of interest.

⁵Gain Error excludes reference error. The ADC gain is calibrated w.r.t. the voltage on the REF2 pin.

Specifications subject to change without notice.

ABSOLUTE MAXIMUM RATINGS*

($T_A = +25^{\circ}\text{C}$ unless otherwise noted)

DV_{DD} to DGND	$-0.3 \text{ V to } 7 \text{ V}$
AV_{DD} , AV_{DD1} to AGND	$-0.3 \text{ V to } 7 \text{ V}$
AV_{DD} , AV_{DD1} to DVDD	$-1 \text{ V to } +1 \text{ V}$
AGND, AGND1 to DGND	$-0.3 \text{ V to } +0.3 \text{ V}$
Digital Inputs to DGND	$-0.3 \text{ V to } DV_{DD} + 0.3 \text{ V}$
Digital Outputs to DGND	$-0.3 \text{ V to } DV_{DD} + 0.3 \text{ V}$
$V_{IN}(+)$, $V_{IN}(-)$ to AGND	$-0.3 \text{ V to } AV_{DD} + 0.3 \text{ V}$
REF1 to AGND	$-0.3 \text{ V to } AV_{DD} + 0.3 \text{ V}$
REF2 to AGND	$-0.3 \text{ V to } AV_{DD} + 0.3 \text{ V}$
DGND, AGND1, AGND2	$\pm 0.3 \text{ V}$
Operating Temperature Range	-40°C to $+85^{\circ}\text{C}$
Storage Temperature Range	-65°C to $+150^{\circ}\text{C}$
Junction Temperature	$+150^{\circ}\text{C}$
θ_{JA} Thermal Impedance	$95^{\circ}\text{C}/\text{W}$
Lead Temperature, Soldering	
Vapor Phase (60 sec)	$+215^{\circ}\text{C}$
Infrared (15 sec)	$+220^{\circ}\text{C}$

*Stresses above those listed under "Absolute Maximum Ratings" may cause permanent damage to the device. This is a stress rating only and functional operation of the device at these or any other conditions above those indicated in the operational section of this specification is not implied. Exposure to absolute maximum rating conditions for extended periods may affect device reliability.

CAUTION

ESD (electrostatic discharge) sensitive device. Electrostatic charges as high as 4000 V readily accumulate on the human body and test equipment and can discharge without detection. Although the AD7722 features proprietary ESD protection circuitry, permanent damage may occur on devices subjected to high energy electrostatic discharges. Therefore, proper ESD precautions are recommended to avoid performance degradation or loss of functionality.

ORDERING GUIDE

Model	Temperature	Package	Package
AD7722AS	-40°C to $+85^{\circ}\text{C}$	44-Pin PQFP	S-44

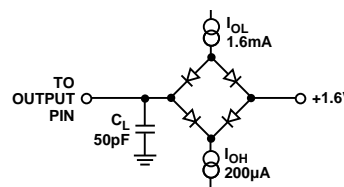

Figure 1. Load Circuit for Timing Specifications



AD7722

TIMING SPECIFICATIONS ($V_{DD} = +5\text{ V} \pm 5\%$, $DV_{DD} = +5\text{ V} \pm 5\%$, $AGND = DGND = 0\text{ V}$, $C_L = 50\text{ pF}$, $T_A = T_{MIN}$ to T_{MAX} , $f_{CLKIN} = 12.5\text{ MHz}$, $SFMT = \text{Logic Low or High}$, $CFMT = \text{Logic Low or High}$)

	Symbol	Min	Typ	Max	Units
CLKIN Frequency	f_{CLK}	0.3	12.5	15	MHz
CLKIN Period ($t_{CLK} = 1/f_{CLK}$)	t_1	0.067	0.08	3.33	μs
CLKIN Low Pulse Width	t_2	$0.45 \times t_1$		$0.55 \times t_1$	
CLKIN High Pulse Width	t_3	$0.45 \times t_1$		$0.55 \times t_1$	
CLKIN Rise Time	t_4	5			ns
CLKIN Fall Time	t_5	5			ns
FSI Low Time	t_6	2			t_{CLK}
FSI Setup Time	t_7	20			ns
FSI Hold Time	t_8	20			ns
CLKIN to SCO Delay	t_9		40		ns
SCO Period ¹	t_{10}	2			t_{CLK}
SCO Transition to FSO High Delay	t_{11}		4	10	ns
SCO Transition to FSO Low Delay	t_{12}		4	10	ns
SCO Transition to SDO Valid Delay	t_{13}		3	8	ns
SCO Transition from FSI ²	t_{14}			2.5	t_{CLK}
SDO Enable Delay Time	t_{15}		30	45	ns
SDO Disable Delay Time	t_{16}		10	30	ns
\overline{DRDY} High Time	t_{17}	2			t_{CLK}
Conversion Time ¹	t_{18}	64			t_{CLK}
\overline{DRDY} to \overline{CS} Setup Time	t_{19}	0			ns
\overline{CS} to \overline{RD} Setup Time	t_{20}	0			ns
\overline{RD} Pulse Width	t_{21}	$t_{CLK} + 20$			ns
Data Access Time after \overline{RD} Falling Edge ³	t_{22}			$t_{CLK} + 40$	ns
Bus Relinquish Time after \overline{RD} Rising Edge	t_{23}			$t_{CLK} + 40$	ns
\overline{CS} to \overline{RD} Hold Time	t_{24}	0			ns
\overline{RD} to \overline{DRDY} High Time	t_{25}		1		t_{CLK}
SYNC/RESET Input Pulse Width	t_{26}	10			ns
DVAL Low Delay from SYNC/RESET	t_{27}			40	ns
SYNC/RESET Low Time Before CLKIN Rising	t_{28}	10			ns
\overline{DRDY} High Delay after SYNC/RESET Low	t_{29}			50	ns
\overline{DRDY} Low Delay after SYNC/RESET Low ¹	t_{30}			(8192 + 64)	t_{CLK}
DVAL High Delay after SYNC/RESET Low ¹	t_{31}			8192	t_{CLK}
CAL Setup Time	t_{34}	10			ns
CAL Pulse Width	t_{35}	1		2	t_{CLK}
Calibration Delay from CAL High	t_{36}			64	t_{CLK}
Unipolar Input Calibration Time, ($\overline{UNI} = "0"$) ¹	t_{37}			(3 × 8192 + 2 × 512)	t_{CLK}
Bipolar Input Calibration Time, ($\overline{UNI} = "1"$) ¹	t_{37}			(4 × 8192 + 3 × 512)	t_{CLK}
Conversion Results Valid, ($\overline{UNI} = "0"$) ¹	t_{38}			(3 × 8192 + 2 × 512 + 64)	t_{CLK}
Conversion Results Valid, ($\overline{UNI} = "1"$) ¹	t_{38}			(4 × 8192 + 3 × 512 + 64)	t_{CLK}

NOTES

¹Guaranteed by design.

²Frame Sync is initiated on falling edge of CLKIN.

³With RD synchronous to CLKIN t_{22} , can be reduced up to 1 t_{CLK} .

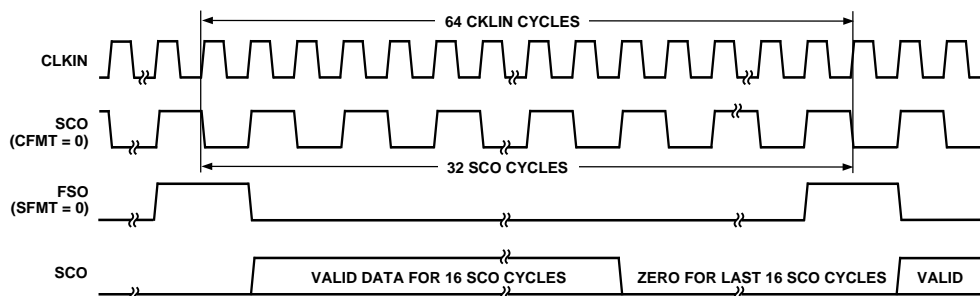

Figure 2a. Generalized Serial Mode Timing ($FSI = \text{Logic Low or High}$, $TSI = \text{DOE}$)

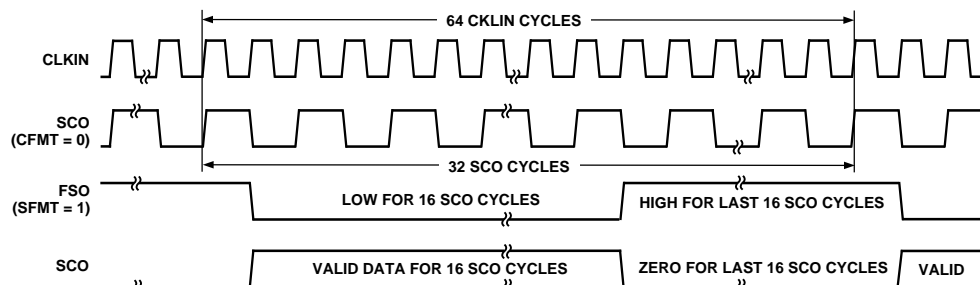

Figure 2b. Generalized Serial Mode Timing ($FSI = \text{Logic Low or High}$, $TSI = \text{DOE}$)

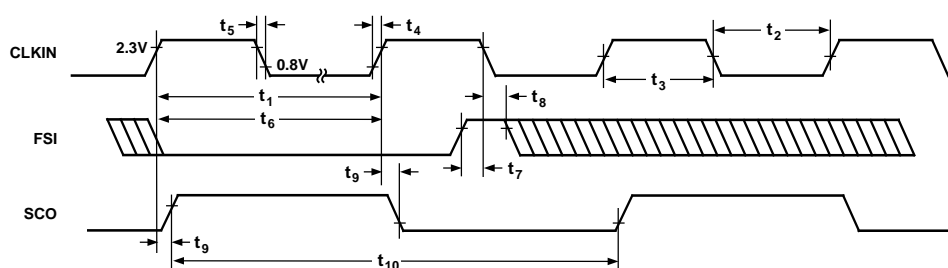

Figure 3. Serial Mode Timing for Clock Input, Frame Sync Input and Serial Clock Output

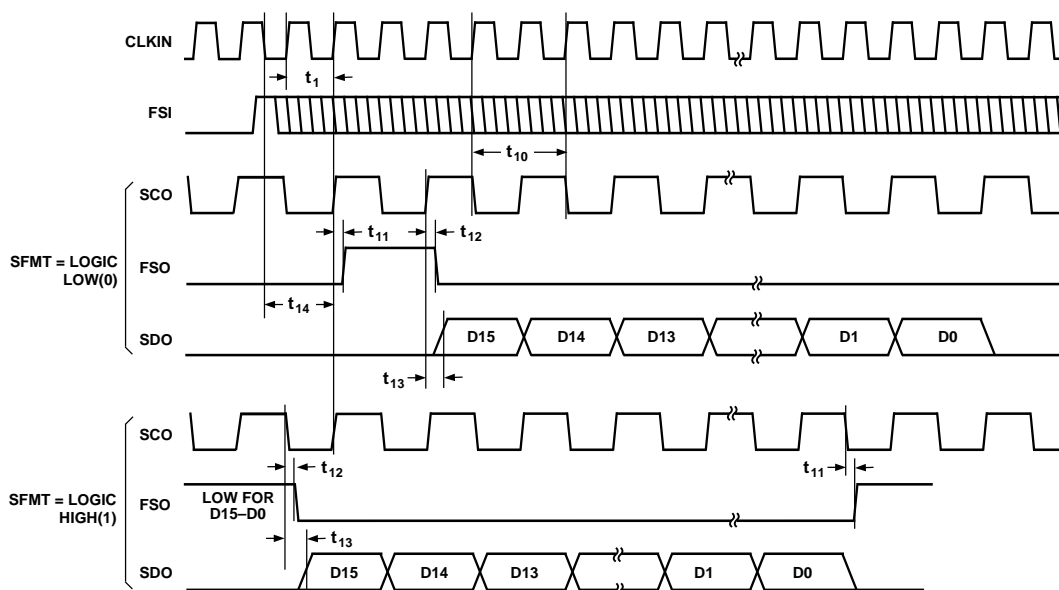

Figure 4. Serial Mode Timing for Frame Sync Input, Frame Sync Output, Serial Clock Output and Serial Data Output ($CFMT = \text{Logic Low}$, $TSI = \text{DOE}$)

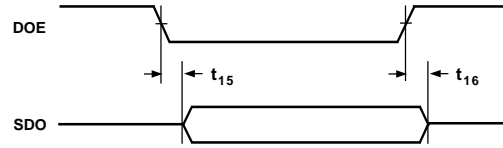

Figure 5. Serial Mode Timing for Data Output Enable and Serial Data Output (TSI = Logic Low)

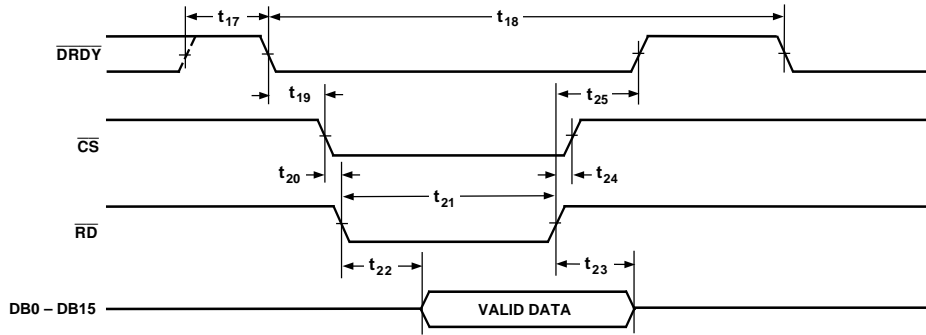

Figure 6. Parallel Mode Read Timing

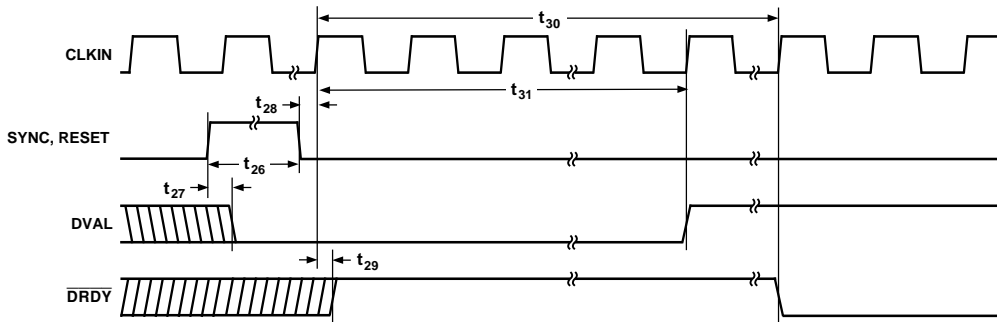

Figure 7. SYNC and RESET Timing, Serial and Parallel Mode

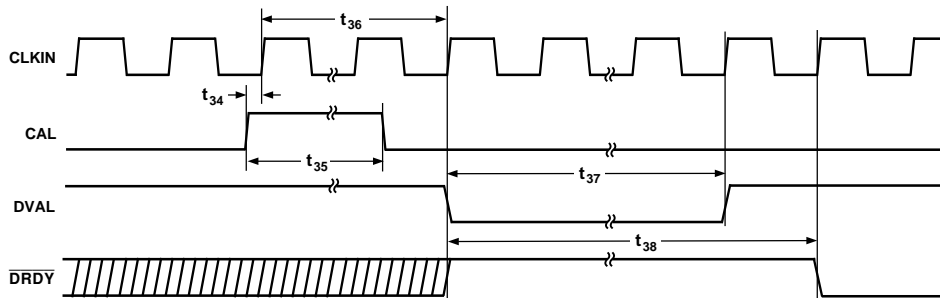
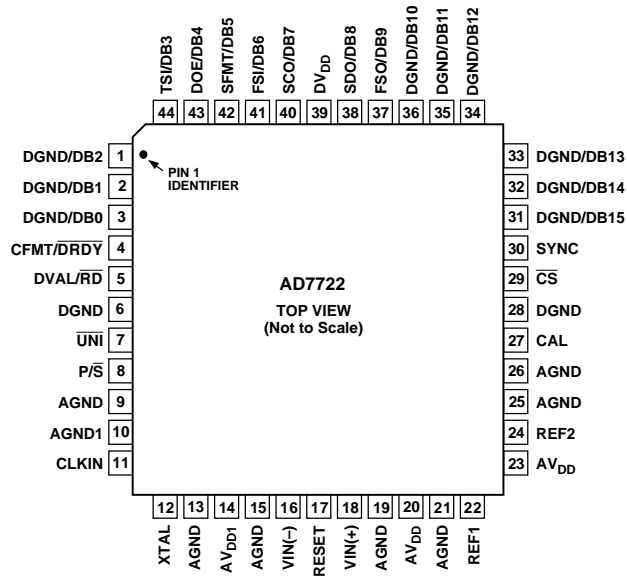

Figure 8. Calibration Timing, Serial and Parallel Mode

PIN FUNCTION DESCRIPTION

Mnemonic	Pin No.	Description
AV _{DD1}	14	Clock logic power supply voltage for the analog modulator, +5 V ± 5%.
AGND1	10	Clock logic ground reference for the analog modulator.
AV _{DD}	20, 23	Analog Power Supply Voltage, +5 V ± 5%.
AGND	9, 13, 15, 19, 21, 25, 26	Ground reference for analog circuitry.
DV _{DD}	39	Digital Power Supply Voltage, +5 V ± 5%.
DGND	6, 28	Ground reference for digital circuitry.
REF1	22	Reference Input/Output. REF1 connects through 3 kΩ to the output of the internal 2.5 V reference and to the input of a buffer amplifier that drives the Σ-Δ modulator. This pin can also be overdriven with an external reference 2.5 V.
REF2	24	Reference Input/Output. REF2 connects to the output of an internal buffer amplifier used to drive the Σ-Δ modulator. When REF2 is used as an input, REF1 must be connected to AGND.
V _{IN} (+)	18	Positive terminal of the differential analog input.
V _{IN} (-)	16	Negative terminal of the differential analog input.
UN _I	7	Analog input range select input. UN _I selects the analog input range for either bipolar or unipolar operation. A logic low input selects unipolar operation. A logic high input selects bipolar operation.
CLKIN	11	Clock Input. Master clock signal for the device. The CLKIN pin interfaces the AD7722 internal oscillator circuit to an external crystal or to an external clock. A parallel resonant, fundamental-frequency, microprocessor-grade crystal and a 1 MΩ resistor should be connected between the CLKIN and XTAL pin with two capacitors connected from each pin to ground. Alternatively, the CLKIN pin can be driven with an external CMOS-compatible clock. The AD7722 is specified with a clock input frequency of 12.5 MHz.
XTAL	12	Oscillator Output. The XTAL pin connects the internal oscillator output to an external crystal. If an external clock is used, XTAL should be left unconnected.
P/S	8	Parallel/Serial interface select input. A logic high configures output data interface for parallel mode operation. Serial mode operation is selected with the P/S set to a logic low.
CAL	27	Calibration Logic Input. A logic high input for a duration of one CLKIN cycle initiates a calibration sequence for the device Gain and Offset Error.
RESET	17	Reset Logic Input. RESET is used to clear the offset and gain calibration registers. RESET is an asynchronous input. RESET allows the user to set AD7722 to an uncalibrated state if the device had been previously calibrated. A rising edge also resets the AD7722 Σ-Δ modulator by shorting the integrator capacitors in the modulator. In addition RESET functions identically to the SYNC pin described below.
C _S	29	Chip select is a level sensitive logic input. C _S enables the output data register for parallel mode read operation. The C _S logic level is sensed on the rising edge of CLKIN. The output data bus is enabled when the rising edge of CLKIN senses a logic low level on C _S if RD is also low. When C _S is sensed high, the output data bits DB15-DB0 will be high impedance. In serial mode tie C _S to a logic low.
SYNC	30	Synchronization Logic Input. SYNC is an asynchronous input. When using more than one AD7722 operated from a common master clock, SYNC allows each ADC's Σ-Δ modulator to simultaneously sample its analog input and update its output data register. A rising edge resets the AD7722 digital filter sequencer counter to zero. After a SYNC, conversion data is not valid until after the digital filter settles (reference Figure 7). DVAL goes low in the serial mode. When the rising edge of CLKIN senses a logic low on SYNC (or RESET) the reset state is released; in parallel mode, DRDY goes high. After the reset state is released, DVAL returns high after 8192 CLKIN cycles (128 × 64/f _{CLKIN}); in parallel mode, DRDY returns low after one additional convolution cycle of the digital filter (64 CLKIN periods), when valid data is ready to be read from the output data register.

PIN CONFIGURATION 44-Pin PQFP (S-44)



PARALLEL MODE PIN FUNCTION DESCRIPTION

Mnemonic	Pin No.	Description
DVAL/ \overline{RD}	5	Read Input is a level sensitive logic input. The \overline{RD} logic level is sensed on the rising edge of CLKIN. This digital input can be used in conjunction with \overline{CS} to read data from the device. The output data bus is enabled when the rising edge of CLKIN senses a logic low level on \overline{RD} if \overline{CS} is also low. When \overline{RD} is sensed high, the output data bits DB15–DB0 will be high impedance.
CFMT/ \overline{DRDY}	2	Data Ready Logic Output. A falling edge indicates a new output word is available to be read from output data register. \overline{DRDY} will return high upon completion of a read operation. If a read operation does not occur between output updates, \overline{DRDY} will pulse high for two CLKIN cycles before the next output update. \overline{DRDY} also indicates when conversion results are available after a SYNC or RESET sequence and when completing a self-calibration.
DGND/DB15	31	Data Output Bit (MSB)
DGND/DB14	32	Data Output Bit
DGND/DB13	33	Data Output Bit
DGND/DB12	34	Data Output Bit
DGND/DB11	35	Data Output Bit
DGND/DB10	36	Data Output Bit
FSO/DB9	37	Data Output Bit
SDO/DB8	38	Data Output Bit
SCO/DB7	40	Data Output Bit
FSI/DB6	41	Data Output Bit
SFMT/DB5	42	Data Output Bit
DOE/DB4	43	Data Output Bit
TSI/DB3	44	Data Output Bit
DGND/DB2	1	Data Output Bit
DGND/DB1	2	Data Output Bit
DGND/DB0	3	Data Output Bit (LSB)

SERIAL MODE PIN FUNCTION DESCRIPTION

Mnemonic	Pin No.	Description
DVAL/ $\overline{\text{RD}}$	5	Data Valid Logic Output. A logic high on DVAL indicates that the conversion result in the output data register is an accurate digital representation of the analog voltage at the input to the Σ - Δ modulator. The DVAL pin is set low for 8,192 CLKIN cycles if the analog input is overranged and after initiating CAL, SYNC or RESET.
CFMT/ $\overline{\text{DRDY}}$	4	Serial Clock Format Logic Input. The clock format pin selects whether the serial data, SDO, is valid on the rising or falling edge of the serial clock, SCO. When CFMT is logic low—SDO is valid on the falling edge of SCO if SFMT is Low; SDO is valid on the rising edge of SCO if SFMT is High. When CFMT is logic high—SDO is valid on the rising edge of SCO if SFMT is Low; SDO is valid on the falling edge of SCO if SFMT is High.
TSI/DB3	44	Time Slot Logic Input. The logic level on TSI sets the active state of the DOE pin. With TSI set logic high, DOE will enable the SDO output buffer when it is a logic high, and vice versa. TSI is used when two AD7722s are connected to the same serial data bus.
DOE/DB4	43	Data Output Enable Logic Input. The DOE pin controls the three-state output buffer of the SDO pin. The active state of DOE is determined by the logic level on the TSI pin. When the DOE logic level equals the level on TSI pin, the serial data output, SDO, is active. Otherwise, SDO will be high impedance. SDO can be three-state after a serial data transmission by connecting DOE to FSO.
SFMT/DB5	42	Serial Data Format Logic Input. The logic level on the SFMT pin selects the format of the FSO signal. A logic low makes the FSO output a pulse one SCO cycle wide occurring every 32 SCO cycles. With SFMT set to a logic high, the FSO signal is a frame pulse that is active low for the duration of the 16 data bit transmission.
FSI/DB6	41	Frame Synchronization Logic Input. The FSI input is used to synchronize the AD7722 serial output data register to an external source. When the falling edge of CLKIN detects a low to high transition, the AD7722 interrupts the current data transmission, reloads the output serial shift register, resets SCO, and transmits the conversion result. Synchronization starts immediately, and the next 127 conversions are invalid. In serial mode, DVAL remains high. FSI inputs applied synchronous to the output data rate do not alter the serial data transmission. If FSI is tied to either a logic high or low, the AD7722 will generate FSO outputs controlled by the logic level on SFMT.
SCO/DB7	40	Serial Data Clock Output. The serial clock output is synchronous to the CLKIN signal and has a frequency one-half the CLKIN frequency. A data transmission frame is 32 SCO cycles long.
SDO/DB8	38	Serial Data Output. The serial data is shifted out MSB first, synchronous with the SCO. A serial data transmission lasts 32 SCO cycles. After the LSB is output, trailing zeros are output for the remaining 16 SCO cycles.
FSO/DB9	37	Frame Sync Output. This output indicates the beginning of a word transmission on the SDO pin. Depending on the logic level of the SFMT pin, the FSO signal is either a positive pulse approximately one SCO period wide or a frame pulse, which is active low for the duration of the 16 data bit transmission (reference Figure 4).
DGND/DB0	3	In serial mode these pins should be tied to DGND.
DGND/DB1	2	
DGND/DB2	1	
DGND/DB10	36	
DGND/DB11	35	
DGND/DB12	34	
DGND/DB13	33	
DGND/DB14	32	
DGND/DB15	31	

AD7722

TERMINOLOGY

Signal-to-Noise Plus Distortion Ratio (S/(N+D))

S/(N+D) is the measured signal-to-noise plus distortion ratio at the output of the ADC. The signal is the rms magnitude of the fundamental. Noise plus distortion is the rms sum of all of the nonfundamental signals and harmonics to half the sampling rate ($F_{\text{CLKIN}}/128$), excluding dc. The ADC is evaluated by applying a low noise, low distortion sine wave signal to the input pins. By generating a Fast Fourier Transform (FFT) plot, the S/(N+D) data can then be obtained from the output spectrum.

Total Harmonic Distortion (THD)

THD is the ratio of the rms sum of the harmonics to the rms value of the fundamental. THD is defined as:

$$THD = 20 \log \left(\frac{SQRT(V_2^2 + V_3^2 + V_4^2 + V_5^2 + V_6^2)}{V_1} \right)$$

where V_1 is the rms amplitude of the fundamental and V_2 , V_3 , V_4 , V_5 and V_6 are the rms amplitudes of the second through sixth harmonics. The THD is also derived from the FFT plot of the ADC output spectrum.

Spurious Free Dynamic Range (SFDR)

Defined as the difference, in dB, between the peak spurious or harmonic component in the ADC output spectrum (up to $F_{\text{CLKIN}}/128$ and excluding dc) and the rms value of the fundamental. Normally, the value of this specification will be determined by the largest harmonic in the output spectrum of the FFT. For input signals whose second harmonics occur in the stop band region of the digital filter, a spur in the noise floor limits the SFDR.

Intermodulation Distortion

With inputs consisting of sine waves at two frequencies, f_a and f_b , any active device with nonlinearities will create distortion products at sum and difference frequencies of $m f_a \pm n f_b$ where $m, n = 0, 1, 2, 3$, etc. Intermodulation distortion terms are those for which neither m nor n are equal to zero. For example, the second order terms include $(f_a + f_b)$ and $(f_a - f_b)$, while the third order terms include $(2f_a + f_b)$, $(2f_a - f_b)$, $(f_a + 2f_b)$ and $(f_a - 2f_b)$.

Testing is performed using the CCIF standard where two input frequencies near the top end of the input bandwidth are used. In this case, the second order terms are usually distanced in frequency from the original sine waves, while the third order terms are usually at a frequency close to the input frequencies. As a result, the second and third order terms are specified separately. The calculation of the intermodulation distortion is as per the THD specification where it is the ratio of the rms sum of the individual distortion products to the rms amplitude of the sum of the fundamental expressed in dB.

Pass-Band Ripple

The frequency response variation of the AD7722 in the defined pass-band frequency range.

Pass-Band Frequency

The frequency up to which the frequency response variation is within the pass-band ripple specification.

Cutoff Frequency

The frequency below which the AD7722's frequency response will not have more than 3 dB of attenuation.

Stop-Band Frequency

The frequency above which the AD7722's frequency response will be within its stop-band attenuation.

Stop-Band Attenuation

The AD7722's frequency response will not have less than 90 dB of attenuation in the stated frequency band.

Integral Nonlinearity

This is the maximum deviation of any code from a straight line passing through the endpoints of the transfer function. The endpoints of the transfer function are minus full scale, a point 0.5 LSB below the first code transition ($100 \dots 00$ to $100 \dots 01$ in bipolar mode, $000 \dots 00$ to $000 \dots 01$ in unipolar mode) and plus full scale, a point 0.5 LSB above the last code transition ($011 \dots 10$ to $011 \dots 11$ in bipolar mode, $111 \dots 10$ to $111 \dots 11$ in unipolar mode). The error is expressed in LSBs.

Differential Nonlinearity

This is the difference between the measured and the ideal 1 LSB change between two adjacent codes in the ADC.

Common-Mode Rejection Ratio

The ability of a device to reject the effect of a voltage applied to both input terminals simultaneously—often through variation of a ground level—is specified as a common-mode rejection ratio. CMRR is the ratio of gain for the differential signal to the gain for the common-mode signal.

Unipolar Offset Error

Unipolar offset error is the deviation of the first code transition ($00 \dots 000$ to $00 \dots 001$) from the ideal differential voltage ($V_{\text{IN}(+) - V_{\text{IN}(-)} + 0.5 \text{ LSB}$) when operating in the unipolar mode.

Bipolar Offset Error

This is the deviation of the midscale transition code ($111 \dots 11$ to $000 \dots 00$) from the ideal differential voltage ($V_{\text{IN}(+) - V_{\text{IN}(-)} - 0.5 \text{ LSB}$) when operating in the bipolar mode.

Gain Error

The first code transition should occur at an analog value 1/2 LSB above -full scale. The last transition should occur for an analog value 1 1/2 LSB below the nominal full scale. Gain error is the deviation of the actual difference between first and last code transitions and the ideal difference between first and last code transitions.

Typical Characteristics—AD7722

($V_{DD} = DV_{DD} = 5.0\text{ V}$, $T_A = +25^\circ\text{C}$; $CLKIN = 12.5\text{ MHz}$, $AIN = 20\text{ kHz}$, Bipolar Mode; $V_{IN(+)} = 0\text{ V}$ to 2.5 V , $V_{IN(-)} = 1.25\text{ V}$ unless otherwise noted)

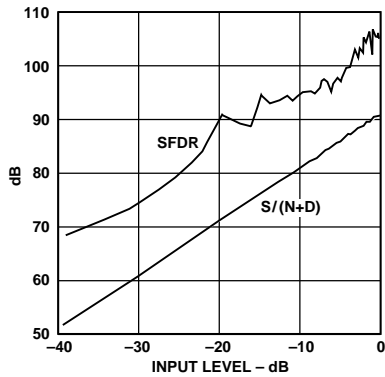

Figure 9. $S/(N+D)$ and SFDR vs. Analog Input Level

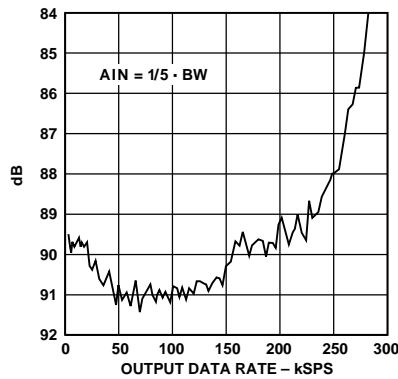

Figure 10. $S/(N+D)$ vs. Output Sample Rate

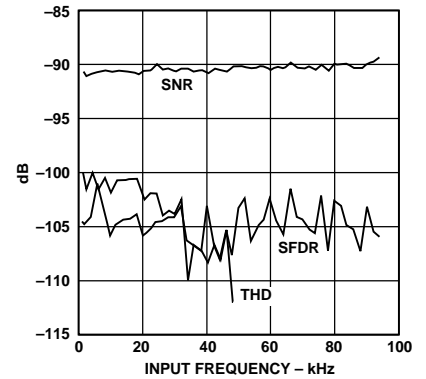

Figure 11. SNR, THD, and SFDR vs. Input Frequency

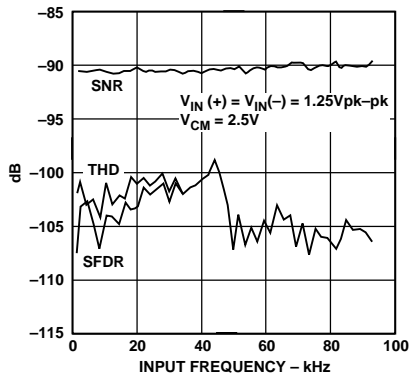

Figure 12. SNR, THD, and SFDR vs. Input Frequency

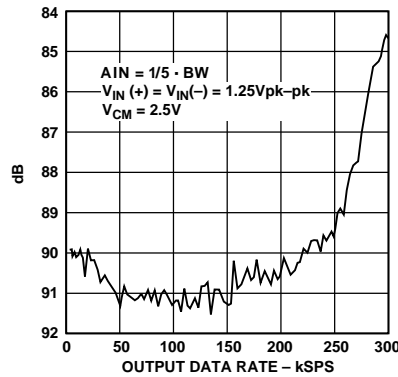

Figure 13. $S/(N+D)$ vs. Output Sample Rate

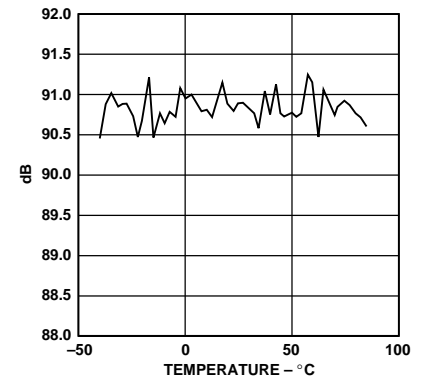

Figure 14. SNR vs. Temperature

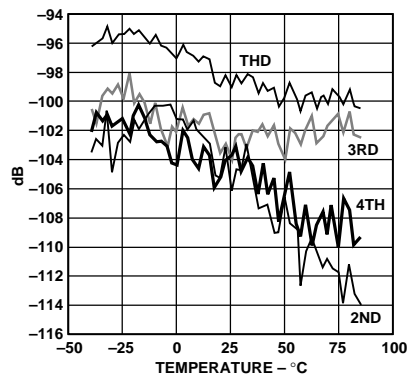

Figure 15. THD vs. Temperature

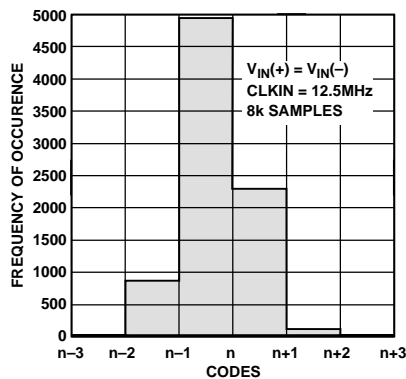

Figure 16. Histogram of Output Codes with DC Input

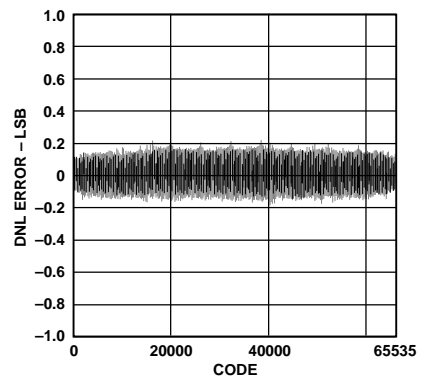

Figure 17. Differential Nonlinearity

AD7722—Typical Characteristics

($A_{V_{DD}} = DV_{DD} = 5.0\text{ V}$, $T_A = +25^\circ\text{C}$; $CLKIN = 12.5\text{ MHz}$, $AIN = 20\text{ kHz}$, Bipolar Mode; $V_{IN(+)} = 0\text{ V}$ to 2.5 V , $V_{IN(-)} = 1.25\text{ V}$ unless otherwise noted)

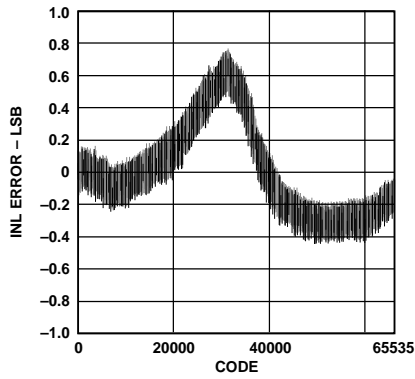

Figure 18. Integral Nonlinearity Error

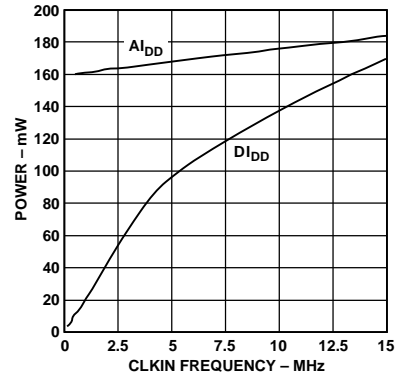

Figure 21. Power Consumption vs. CLKIN Frequency

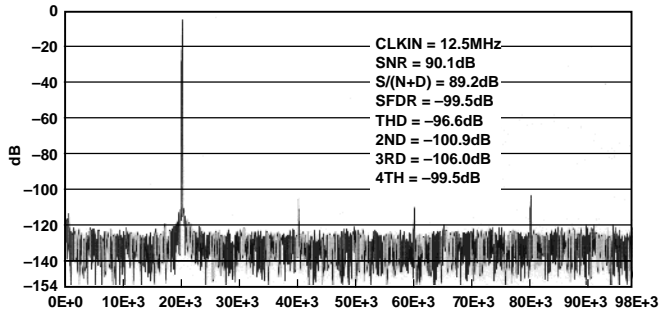

Figure 19. 16K Point FFT

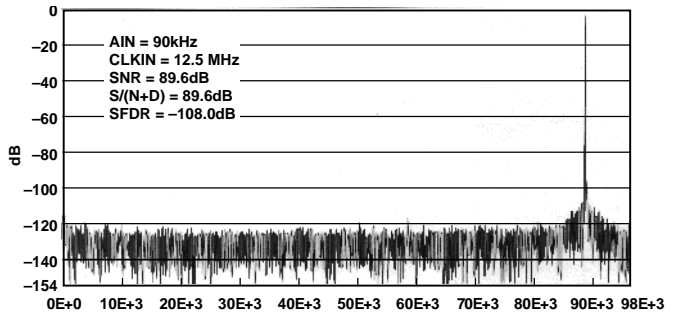

Figure 22. 16K Point FFT

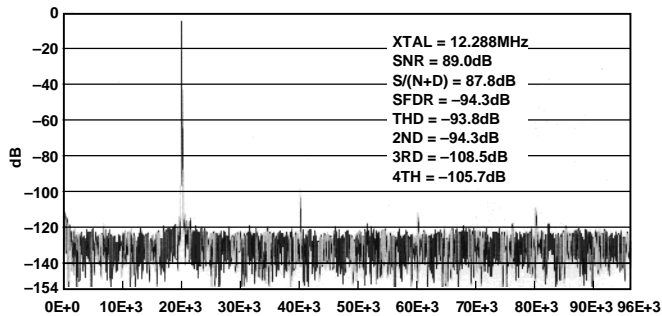

Figure 20. 16K Point FFT

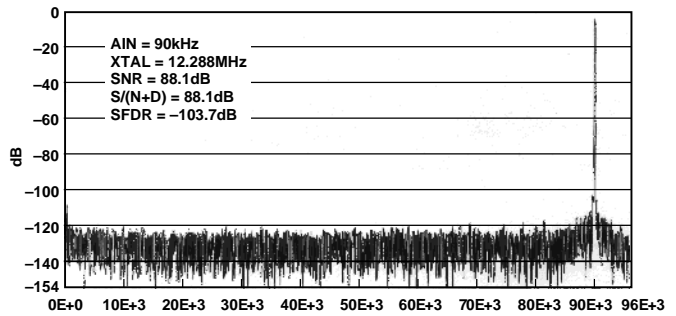

Figure 23. 16K Point FFT

CIRCUIT DESCRIPTION

The AD7722 ADC employs a sigma-delta conversion technique that converts the analog input into a digital pulse train. The analog input is continuously sampled by a switched capacitor modulator at twice the rate of the clock input frequency, $2 \times f_{CLKIN}$. The digital data that represents the analog input is in the 1's density of the bit stream at the output of the sigma-delta modulator. The modulator outputs a bit stream at a data rate equal to f_{CLKIN} .

Due to the high oversampling rate, which spreads the quantization noise from 0 to $f_{CLKIN}/2$, the noise energy contained in the band of interest is reduced (Figure 24a). To reduce the quantization noise further, a high order modulator is employed to shape the noise spectrum so that most of the noise energy is shifted out of the band of interest (Figure 24b).

The digital filter that follows the modulator provides three main functions. The filter performs sophisticated averaging on the 1 bit samples from the output of the modulator, while removing the large out of band quantization noise (Figure 24c). Lastly the digital filter reduces the data rate from f_{CLKIN} at the input of the filter to $f_{CLKIN}/64$ at the output of the filter. The AD7722 output data rate, F_S , is a little over twice the signal bandwidth, which guarantees that there is no loss of data in the signal band.

Digital filtering has certain advantages over analog filtering. First, since digital filtering occurs after the A/D conversion, it can remove noise injected during the conversion process. Analog filtering cannot remove noise injected during conversion. Second, the digital filter combines low pass-band ripple with a steep roll off, while also maintaining a linear phase response.

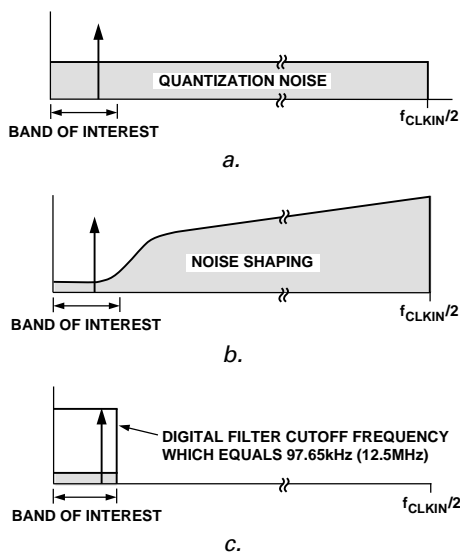

Figure 24. Sigma-Delta ADC

The AD7722 employs two Finite Impulse Response (FIR) filters in series. The first filter is a 384 tap filter that samples the output of the modulator at f_{CLKIN} . The second filter is a 151 tap half-band filter that samples the output of the first filter at $f_{CLKIN}/32$ and decimates by 2. The implementation of this filter architecture results in a filter with a group delay of 42 conversions (84 conversions for settling to a full-scale step).

The digital filter provides 6 dB of attenuation at a frequency ($f_{CLKIN}/128$) one-half its output rate. With a clock frequency of 12.5 MHz, the digital filter has a pass-band frequency of 90.625 kHz, a cutoff frequency is 96.92 kHz and stop-band frequency of 104.6875 kHz.

Due to the sampling nature of the digital filter, the filter does not provide any rejection at integer multiples of its input sampling frequency. The filter response in Figure 25a shows the unattenuated frequency bands occurring at $n \times f_{CLKIN}$ where $n = 1, 2, 3, \dots$. At these frequencies, there are frequency bands $\pm f_{3dB}$ wide (f_{3dB} is the -3 dB bandwidth of the digital filter) on either side of $n \times f_{CLKIN}$ where noise passes unattenuated to the output. Out of band signals coincident with any of the filter images are aliased into the pass band. However, due to the AD7722's high oversampling ratio, these bands occupy only a small fraction of the spectrum, and most broadband noise is filtered. This means that the antialias filtering requirements in front of the AD7722 are considerably reduced versus a conventional converter with no on-chip filtering. Figure 25b shows the frequency response of an antialias filter. With a -3 dB corner frequency set at $f_{CLKIN}/64$, a single pole filter will provide 36 dB of attenuation at f_{CLKIN} .

Depending on the application, however, it may be necessary to provide additional antialias filtering prior to the AD7722 to eliminate unwanted signals from the frequency bands the digital filter passes. It may also be necessary in some applications to provide analog filtering in front of the AD7722 to ensure that differential noise signals outside the band of interest do not saturate the analog modulator.

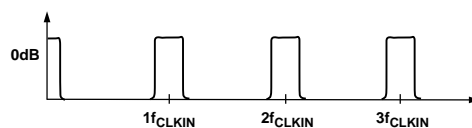

Figure 25a. Digital Filter Frequency Response

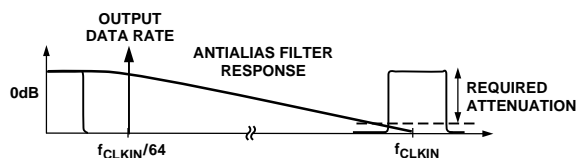

Figure 25b. Frequency Response of Antialias Filter

AD7722

APPLYING THE AD7722

Analog Input Range

The AD7722 uses differential inputs to provide common-mode noise rejection (i.e., the converted result will correspond to the differential voltage between the two inputs). The absolute voltage on both inputs must lie between AGND and AV_{DD} .

In the unipolar mode, the full-scale analog input range ($V_{IN}(+) - V_{IN}(-)$) is 0 V to V_{REF2} . The output code is straight binary in the unipolar mode with 1 LSB = 38 μ V. The ideal transfer function is shown in Figure 26.

In bipolar mode, the full-scale input range is $\pm V_{REF2}/2$. The bipolar mode allows complementary input signals. As another example, in bipolar mode, $V_{IN}(-)$ can be connected to a dc bias voltage to allow a single-ended input on $V_{IN}(+)$ equal to $V_{BIAS} \pm V_{REF2}/2$. In bipolar mode the output code is 2s complement with 1 LSB = 38 μ V. The ideal transfer function is shown in Figure 27.

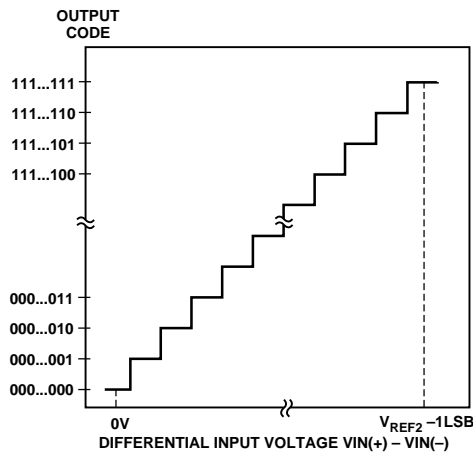

Figure 26. Unipolar Mode Transfer Function

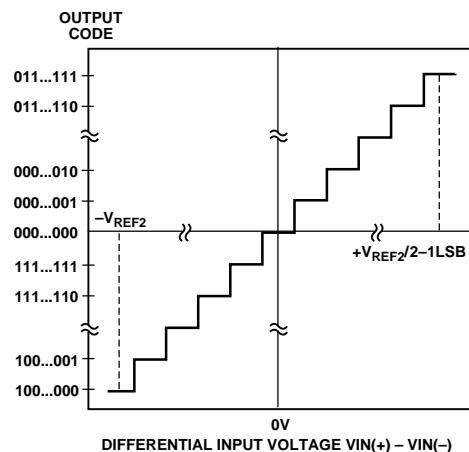

Figure 27. Bipolar Mode Transfer Function

Differential Inputs

The analog input to the modulator is a switched capacitor design. The analog signal is converted into charge by highly linear sampling capacitors. A simplified equivalent circuit diagram of the analog input is shown in Figure 28. A signal source driving the analog input must be able to provide the charge onto the sampling capacitors every half $CLKIN$ cycle and settle to the required accuracy within the next half cycle.

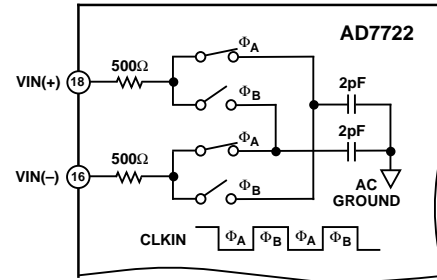

Figure 28. Analog Input Equivalent Circuit

Since the AD7722 samples the differential voltage across its analog inputs, low noise performance is attained with an input circuit that provides low common-mode noise at each input. The amplifiers used to drive the analog inputs play a critical role in attaining the high performance available from the AD7722.

When a capacitive load is switched onto the output of an op amp, the amplitude will momentarily drop. The op amp will try to correct the situation and in the process hits its slew rate limit. This nonlinear response, which can cause excessive ringing, can lead to distortion. To remedy the situation, a low-pass RC filter can be connected between the amplifier and the input to the AD7722 as shown in Figure 29. The external capacitor at each input aids in supplying the current spikes created during the sampling process. The resistor in this diagram, as well as creating the pole for the antialiasing, isolates the op amp from the transient nature of the load.

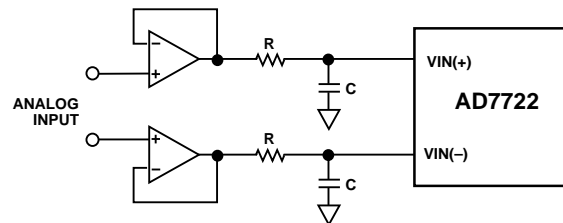

Figure 29. Simple RC Antialiasing Circuit

The differential input impedance of the AD7722 switched capacitor input varies as a function of the $CLKIN$ frequency, given by the equation:

$$Z_{IN} = \frac{10^9}{8 \times f_{CLKIN}} \text{ k}\Omega$$

Even though the voltage on the input sampling capacitors may not have enough time to settle to the accuracy indicated by the resolution of the AD7722, as long as the sampling capacitor charging follows the exponential curve of RC circuits, only the gain accuracy suffers if the input capacitor is switched away too early.

An alternative circuit configuration for driving the differential inputs to the AD7722 is shown in Figure 30.

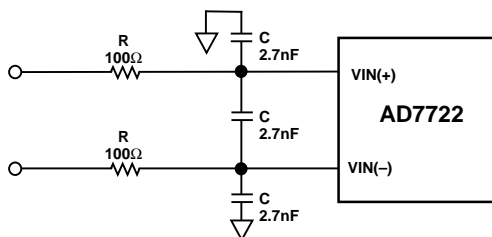

Figure 30. Differential Input with Antialiasing

A capacitor between the two input pins sources or sinks charge to allow most of the charge that is needed by one input to be effectively supplied by the other input. This minimizes undesirable charge transfer from the analog inputs to and from ground. The series resistor isolates the operational amplifier from the current spikes created during the sampling process and provides a pole for antialiasing. The -3 dB cutoff frequency (f_{3dB}) of the antialias filter is given by Equation 1, and the attenuation of the filter is given by Equation 2.

$$f_{3dB} = \frac{1}{6\pi RC} \quad (1)$$

$$\text{Attenuation} = 20 \log \left(1 / \sqrt{1 + \left(\frac{f}{f_{3dB}} \right)^2} \right) \quad (2)$$

The choice of the filter cutoff frequency will depend on the amount of roll-off that is acceptable in the pass band of the digital filter and the required attenuation at the first image frequency. For example, when operating the AD7722 with a 12.5 MHz clock; with the typical values of R and C of 100 Ω and 2.7 nF shown in Figure 30, the -3 dB cutoff frequency (f_{3dB}) creates less than 1 dB of in band (90.625 kHz) roll-off and provides about 36 dB attenuation at the first image frequency.

The capacitors used for the input antialiasing circuit must have low dielectric absorption to avoid distortion. Film capacitors such as Polypropylene, Polystyrene or Polycarbonate are suitable. If ceramic capacitors are used, they must have NP0 dielectric.

Applying the Reference

The reference circuitry used in the AD7722 includes an on-chip 2.5 V band gap reference and a reference buffer circuit. The block diagram of the reference circuit is shown in Figure 31. The internal reference voltage is connected to REF1 through a 3 kΩ resistor and is internally buffered to drive the analog modulator's switched cap DAC (REF2). When using the

internal reference, connect 100 nF between REF1 and AGND. If the internal reference is required to bias external circuits, use an external precision op amp to buffer REF1.

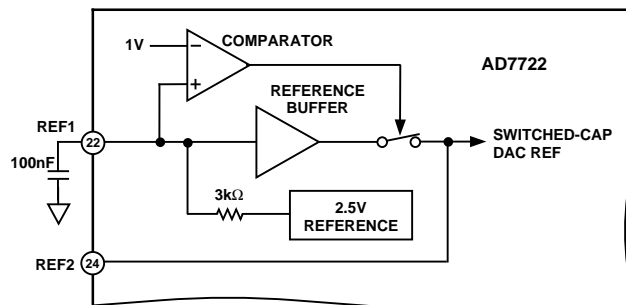

Figure 31. Reference Circuit Block Diagram

The AD7722 can operate with its internal reference or an external reference can be applied in two ways. An external reference can be connected to REF1, overriding the internal reference. However, there will be an error introduced due to the offset of the internal buffer amplifier. For lowest system gain errors when using an external reference, REF1 is grounded (disabling the internal buffer) and the external reference is connected to REF2.

In all cases, since the REF2 voltage connects to the analog modulator, a 100 nF capacitor must connect directly from REF2 to AGND. The external capacitor provides the charge required for the dynamic load presented at the REF2 pin (Figure 32).

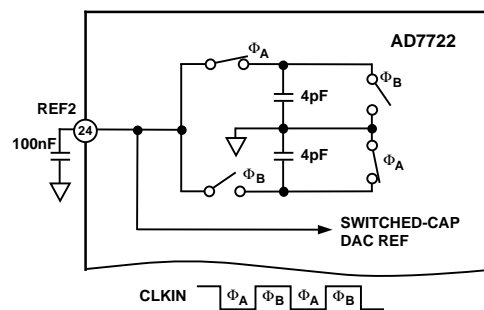

Figure 32. REF2 Equivalent Input Circuit

The AD780 is ideal to use as an external reference with the AD7722. Figure 33 shows a suggested connection diagram.

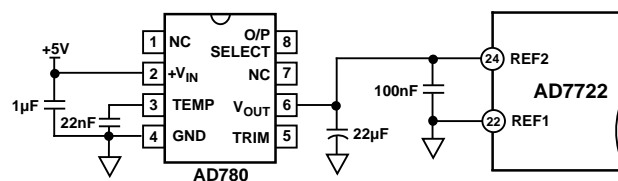

Figure 33. External Reference Circuit Connection

AD7722

Input Circuits

Figures 34 and 35 show two simple circuits for bipolar mode operation. Both circuits accept a single-ended bipolar signal source and create the necessary differential signals at the input to the ADC.

The circuit in Figure 34 creates a 0 V to 2.5 V signal at the VIN(+) pin to form a differential signal around an initial bias of 1.25 V. For single-ended applications best THD performance is obtained with VIN(−) set to 1.25 V rather than 2.5 V. The input to the AD7722 can also be driven differentially with a complementary input as shown in Figure 35.

In this case, the input common-mode voltage is set to 2.5 V. The 2.5 V p-p full-scale differential input is obtained with a 1.25 V p-p signal at each input in antiphase. This configuration minimizes the required output swing from the amplifier circuit and is useful for single supply applications.

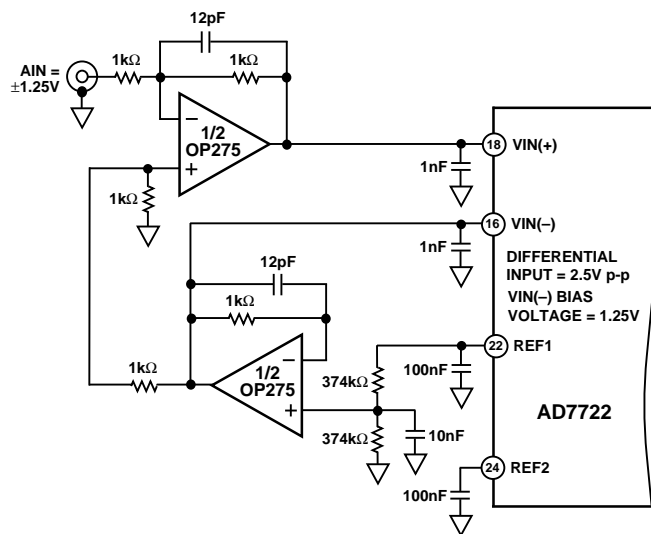

Figure 34. Single-Ended Analog Input Circuit for Bipolar Mode Operation

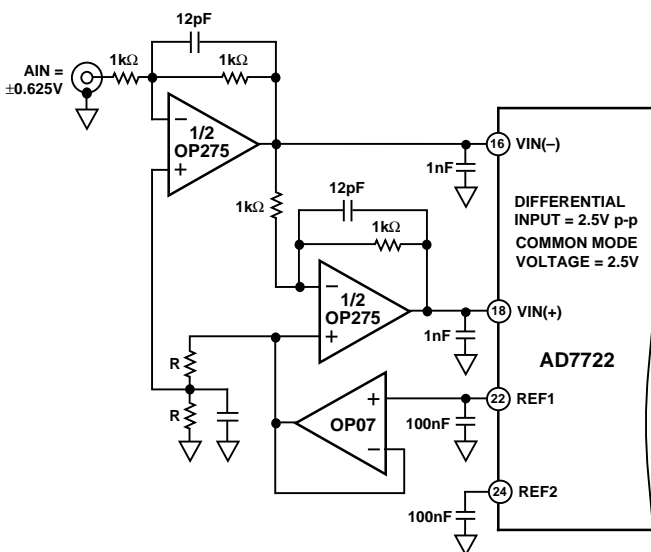

Figure 35. Single-Ended to Differential Analog Input Circuit for Bipolar Mode Operation

The 1 nF capacitors at each ADC input store charge to aid the amplifier settling as the input is continuously sampled. A resistor in series with the drive amplifier output and the 1 nF input capacitor may also be used to create an antialias filter.

Clock Generation

The AD7722 contains an oscillator circuit to allow a crystal or an external clock signal to generate the master clock for the ADC. The connection diagram for use with crystal is shown in Figure 36, below. Consult the crystal manufacturer's recommendation for the load capacitors.

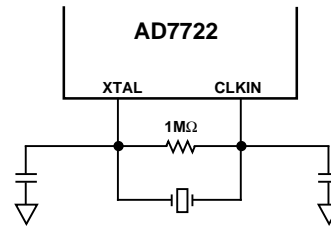

Figure 36. Crystal Oscillator Connection

An external clock must be free of ringing and have a minimum rise time of 5 ns. Degradation in performance can result, as high edge rates increase coupling that can generate noise in the sampling process. The connection diagram for an external clock source (Figure 37) shows a series damping resistor connected between the clock output and the clock input to the AD7722. The optimum resistor will depend on the board layout and the impedance of the trace connecting to the clock input.

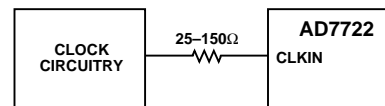

Figure 37. External Clock Oscillator Connection

A low phase-noise clock should be used to generate the ADC sampling clock because sampling clock jitter effectively modulates the input signal and raises the noise floor. The sampling clock generator should be isolated from noisy digital circuits, grounded and heavily decoupled to the analog ground plane.

The sampling clock generator should be referenced to the analog ground plane in a split-ground system. However, this is not always possible because of system constraints. In many cases, the sampling clock must be derived from a higher frequency multipurpose system clock that is generated on the digital ground plane. If the clock signal is passed between its origin on a digital ground plane to the AD7722 on the analog ground plane, the ground noise between the two planes adds directly to the clock and will produce excess jitter. The jitter can cause degradation in the signal-to-noise ratio and also produce unwanted harmonics.

This can be remedied somewhat by transmitting the sampling clock signal as a differential one, using either a small RF transformer or a high speed differential driver and receiver such as PECL. In either case, the original master system clock should be generated from a low phase noise crystal oscillator.

Varying the Master Clock

Although the AD7722 is specified with a master clock of 12.5 MHz, the AD7722 operates with clock frequencies up to 15 MHz and as low as 300 kHz. The input sample rate, output word rate, and the frequency response of the digital filter are directly proportional to the master clock frequency. For example, reducing the clock frequency to 5 MHz leads to an analog input sample rate of 10 MHz, an output word rate of 78.125 kSPS, a pass-band frequency of 36.25 kHz, a cutoff frequency of 38.77 kHz, and a stop band frequency of 41.875 kHz.

SYSTEM SYNCHRONIZATION AND CONTROL

The AD7722 digital filter contains a sequencer block that controls the digital interface and all the control logic needed to operate the digital filter. A 14-bit cycle counter keeps track of where the filters are in their overall operating cycle and decodes the digital interface signals to the AD7722. The cycle counter has a number of important transition points. In particular, the bottom six bits control the convolution counter that decimates by 64 to the update rate of the output data register. The counter's top bit is used to provide ample time (8192 CLKIN cycles) to allow the modulator and digital filter to settle as the AD7722 sequences through its autocalibration process. The counter increments on the rising edge of the signal at the CLKIN pin and all of the digital I/O signals are synchronous with this clock. The upper bit of this counter also controls when DVAL or DRDY indicates valid data is available in the output data register after a SYNC, RESET, CAL or an initial FSI. During normal operation the delay of 128 conversion (8192 CLKIN cycles) should not be confused with actual settling time (5376 CLKIN cycles) and group delay (2688 CLKIN cycles) of the of the digital filter.

SYNC Input

The SYNC input provides a synchronization function for use in parallel or serial mode. SYNC allows the user to start gathering samples of the analog input from a known point in time. This allows a system using multiple AD7722s, operated from a common master clock, to be synchronized so that each ADC updates its output register simultaneously. The SYNC input resets the digital filter without affecting the contents of the calibration registers.

In a system using multiple AD7722s, a common signal to their sync input will synchronize their operation. On the rising edge of SYNC, the digital filter sequencer counter is reset to zero. The filter is held in a reset state until a rising edge on CLKIN senses SYNC low. A SYNC pulse, one CLKIN cycle long, can be applied synchronous to the falling edge of CLKIN. This way, on the next rising edge of CLKIN, SYNC is sensed low, the filter is taken out of its reset state and multiple parts start to gather input samples.

In serial mode DVAL remains low for 8192 CLKIN cycles to allow the modulator and digital filter to settle. In parallel mode DRDY remains high for an additional 64 CLKIN cycles when valid data is loaded into the output register. After a SYNC, conversion data is not valid until the digital filter settles (reference Figure 7).

DVAL

The DVAL pin, when used in the serial mode, indicates if invalid data may be present at the ADC output. There are four events which can cause DVAL to be deasserted and they have different implications for how long the results should be considered invalid.

DVAL is set low if there is an overflow condition in the first stage of the digital filter. The overflow can result from an analog input signal nearly twice the allowable maximum input span. When an overflow condition is detected, DVAL is set low for 64 CLKIN cycles, (one output period) and the output data is clipped to either positive or negative full scale depending on the sign of the overflow. After the next convolution is completed (64 CLKIN cycles), if the overflow condition does not exist, DVAL goes high to indicate a valid output is available. Otherwise DVAL will remain low until the overflow condition is eliminated.

The second stage digital filter can overflow as a result of overflow from the first stage. The overflow condition is detected when the second stage filter calculates a conversion result that exceeds either plus or minus full scale (i.e., below -32,768 or above 32,767 in bipolar mode). When the overflow is detected, DVAL is set low, and the output register is updated with either positive or negative full scale, depending on the sign of the overload. After the next convolution is completed, DVAL returns high if the next conversion result is within the full-scale range.

As with all high order sigma-delta modulators, large overloads on the analog input can cause the modulator to go unstable. The modulator is designed to be stable with input signals as high as twice full scale within the input bandwidth. Out of band signals as high as the full-scale range will not cause instability. When instability is detected by internal circuits, DVAL is set low, and the output is clipped to either positive or negative full scale depending on the polarity of the overload. The modulator is reset to a stable state, and the digital filter sequencer counter is reset. DVAL is set low for a minimum of 8192 CLKIN cycles while the modulator settles out, and the digital filter accumulates new samples. DVAL returns high to indicate valid data is available from the serial output register 8192 CLKIN cycles after the overload condition is removed.

Lastly, DVAL also indicates when valid data is available at the serial interface after initial power-up or upon completion of a CAL, RESET or SYNC sequence.

Reset Input

The AD7722 RESET input controls the digital filter the same as the SYNC input described above. Additionally, it resets the modulator by shorting its integrator capacitors and clears the on-chip calibration registers so that the conversion results are not corrected for offset or gain error.

Power-On Reset

A power-on reset function is provided to reset the AD7722 internal logic after initial power-up. On power-up the offset and gain calibration registers are cleared.

AD7722

Offset and Gain Calibration

A calibration of offset and gain errors can be performed in both serial and parallel modes by initiating a calibration cycle. During this cycle, offset and gain registers in the filter are loaded with values representing the dc offset of the analog modulator and a modulator gain correction factor. The correction factors are determined by an on-chip microcontroller measuring the conversion results for three different input conditions: minus full scale (-FS), plus full scale (+FS), and midscale. In normal operation, the offset register is subtracted from the digital filter output, and this result is then multiplied by the gain correction factor to obtain an offset and gain corrected final result.

The calibration cycle is controlled by internal logic, and the user need only initiate the cycle. A calibration is initiated when the rising edge of CLKIN senses a high level on the CAL input. There is an uncertainty of up to 64 CLKIN cycles before the calibration cycle actually begins because the current conversion must complete before calibration commences. The calibration values loaded into the registers only apply for the particular analog input mode (bipolar/unipolar) selected when initiating the calibration cycle. On changing to a different analog input mode, a new calibration must be performed.

During the calibration cycle, in unipolar mode, the offset of the analog modulator is evaluated; the differential inputs to the modulator are shorted internally to AGND. Once calibration begins, DVAL goes low and $\overline{\text{DRDY}}$ goes high indicating there is invalid data in the output register. After 8192 CLKIN cycles, when the modulator and digital filter settle, the average of eight output results (512 CLKIN cycles) is calculated and stored in the offset register. In unipolar mode, this result also represents minus full scale, required to calculate the gain correction factor. The gain correction factor can then be determined by internally switching the inputs to +FS ($V_{\text{REF}2}$). The positive input of the modulator is switched to the reference voltage and the negative input to AGND. Again, when the modulator and digital filter settle, the average of the eight output results is used to calculate the gain correction factor.

In bipolar mode, an additional measurement is required since zero scale is not the same as -FS. Therefore, calibration in bipolar mode requires an additional 8704 CLKIN cycles. Zero scale is similarly determined by shorting both analog inputs to AGND. Then the inputs are internally reconfigured to apply +FS and -FS ($+V_{\text{REF}2}/2$ and $-V_{\text{REF}2}/2$) to determine the gain correction factor.

After the calibration registers have been loaded with new values, the inputs of the modulator are switched back to the input pins. However, correct data is available at the interface only after the modulator and filter have settled to the new input values.

Should the part see a rising edge on the SYNC or RESET pin during a calibration cycle, the calibration cycle is discontinued, and a synchronization operation or reset will be performed.

The calibration registers are static. They need to be updated only if unacceptable drifts in analog offsets or gain are expected. After power-up, a RESET is not mandatory since power-on reset circuitry clears the offset and gain registers. Care must be taken to ensure the CAL pin is held low during power-up. Before initiating a calibration routine, ensure the supplies and reference input have settled, and that the voltage on the analog input pins is between the supply voltages.

DATA INTERFACING

The AD7722 offers a choice of serial or parallel data interface options to meet the requirements of a variety of system configurations. In parallel mode, multiple AD7722s can be easily configured to share a common data bus. Serial mode is ideal when it is required to minimize the number of data interface lines connected to a host processor. In either case, careful attention to the system configuration is required to realize the high dynamic range available with the AD7722. Consult the recommendations in the “Power Supply Grounding and Layout” section. The following recommendations for parallel interfacing also apply for the system design in serial mode.

Parallel Interface

When using the AD7722, place a buffer/latch adjacent to the converter to isolate the converter’s data lines from any noise which may be on the data bus. Even though the AD7722 has three-state outputs, use of an isolation latch represents good design practice. This arrangement will inject a small amount of digital noise on the AD7722 ground plane; these currents should be quite small and can be minimized by ensuring that the converter input/output does not drive a large fanout (they normally can’t by design). Minimizing the fanout on the AD7722’s digital port will also keep the converter logic transitions relatively free from ringing and thereby minimize any potential coupling into the analog port of the converter.

The simplified diagram (Figure 38) shows how the parallel interface of the AD7722 can be configured to interface with the system data bus of a microprocessor or a modern microcontroller such as the MC68HC16 or 8XC251.

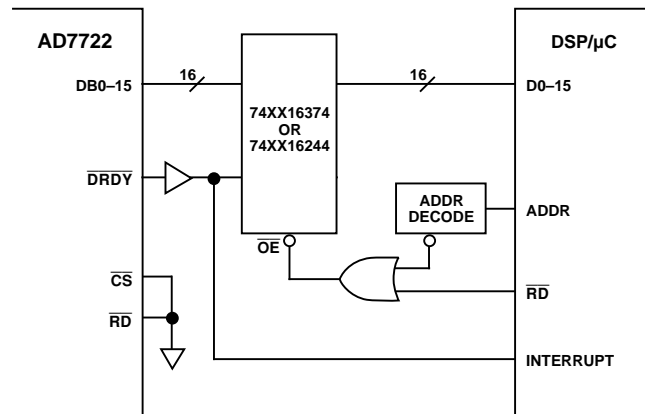

Figure 38. Parallel Interface Connection

With $\overline{\text{CS}}$ and $\overline{\text{RD}}$ tied permanently low the data output bits are always active. When the $\overline{\text{DRDY}}$ output goes high for two CLKIN cycles, the rising edge of $\overline{\text{DRDY}}$ is used to latch the conversion data before a new conversion result is loaded into the output data register. The falling edge of $\overline{\text{DRDY}}$ then sends an appropriate interrupt signal for interface control. Alternatively if buffers are used instead of latches the falling edge of $\overline{\text{DRDY}}$ provides the necessary interrupt when a new output word is available from the AD7722.

SERIAL INTERFACE

The AD7722's serial data interface port allows easy interfacing to industry standard digital signal processors. The AD7722 operates solely in the master mode providing three serial data output pins for transfer of the conversion results. The serial data clock output (SCO), serial data output (SDO) and frame sync output (FSO) are all synchronous with CLKIN. SCO frequency is always one-half the CLKIN frequency. FSO is continuously output at the conversion rate of the ADC (FCLKIN/64). The generalized timing diagrams in Figure 2 show how the AD7722 may be used to transmit its conversion results.

Serial data shifts out of the SDO pin synchronous with SCO. The FSO is used to frame the output data transmission to an external device. An output data transmission is 32 SCO cycles in duration. The serial data shifts out of the SDO pin MSB first, LSB last for a duration of 16 SCO cycles. For the next 16 SCO cycles SDO outputs zeros.

Two control inputs, SFMT and CFMT, select the format for the serial data transmission. FSO is either a pulse (approximately one SCO cycle in duration) or a square wave with a period of 32 SCO cycles, depending on the state of the SFMT. The logic level applied to SFMT also determines if the serial data is valid on the rising or falling edge of the SCO. The clock format pin, CFMT, simply switches the phase of SCO for the selected FSO format.

With a logic low level on SFMT and CFMT set low (Figure 4), FSO pulses high for one SCO cycle at the beginning of a data transmission frame. When FSO goes low, the MSB is available on the SDO pin after the rising edge of SCO and can be latched on the SCO falling edge.

With a logic high level on SFMT and CFMT set low (Figure 4), the data on the SDO pin is available after the falling edge of SCO and can be latched on the SCO rising edge. FSO goes low at the beginning of a data transmission frame when the MSB is available and returns high after 16 SCO cycles.

The Frame Sync Input (FSI) can be used if the AD7722 conversion process must be synchronized to an external source. FSI is an optional signal; if FSI is grounded or tied high frame syncs are internally generated. Frame sync allows the conversion data presented to the serial interface to be a filtered and decimated result derived from a known point in time. FSI can be applied once after power-up, or it can be a periodic signal,

synchronous to CLKIN, occurring every 64 CLKIN cycles. When FSI is applied for the first time, or if a low to high transition is detected that is not synchronized to the output word rate, the next 127 conversions should be considered invalid while the digital filter accumulates new samples. Figure 4 shows how the frame sync signal resets the serial output interface and how the AD7722 will begin to output its serial data transmission frame. A common frame sync signal can be applied to two or more AD7722s to synchronize them to a common master clock.

Two Channel Multiplexed Operation

Three additional serial interface control pins (DOE, TSI and CFMT) are provided. The connection diagram in Figure 39 shows how they are used to allow the serial data outputs of two AD7722s to easily share one serial data line. Since a serial data transmission frame lasts 32 SCO cycles, two AD7722s can share a single data line by alternating transmission of their 16-bit output data onto one SDO pin.

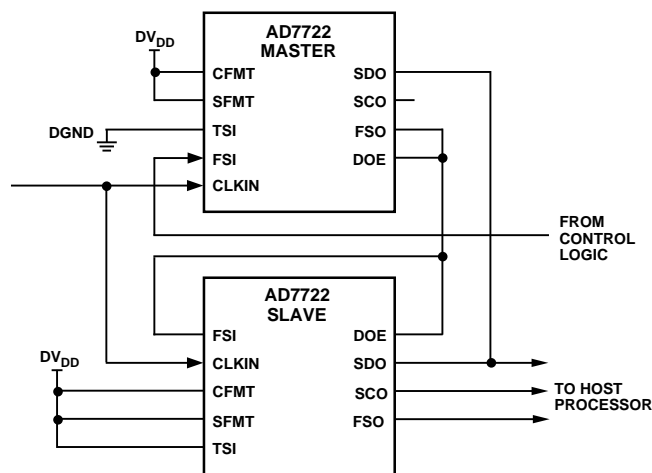

Figure 39. Connection for Two Channel Multiplexed Operation

The Data Output Enable pin (DOE) controls SDO's output buffer. When the logic level on DOE matches the state of the TSI pin, the SDO output buffer drives the serial dataline; otherwise the output of the buffer goes high impedance. The serial format pin (SFMT) is set high to choose the frame sync output format. The clock format pin (CFMT) is set high so that

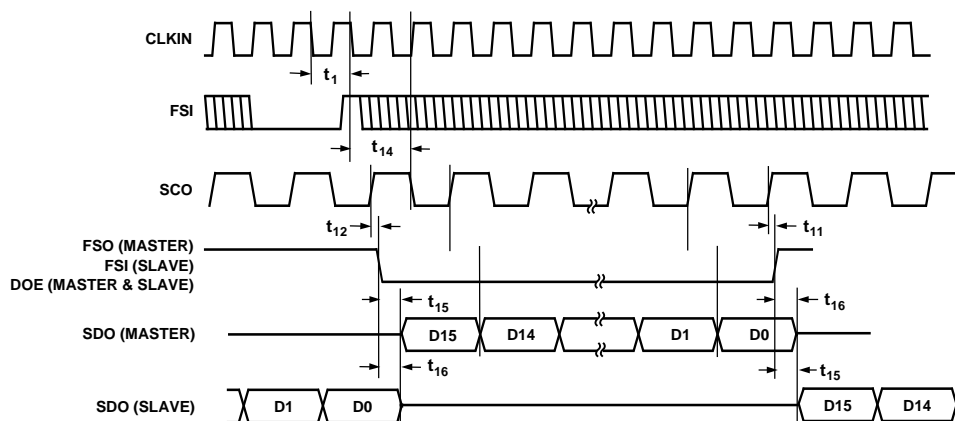

Figure 40. Timing for Two Channel Multiplexed Operation

AD7722

serial data is made available on SDO after the rising edge of SCO and can be latched on the SCO falling edge.

The master device is selected by setting TSI to a logic low and connecting its FSO to DOE. The slave device is selected with its TSI pin tied high, and both its FSI and DOE are controlled from the master's FSO. Since the FSO of the master controls the DOE input of both the master and slave, one ADC's SDO is active while the other is high impedance (Figure 40). When the master transmits its conversion result during the first 16 SCO cycles of a data transmission frame, the low level on DOE sets the slave's SDO high impedance. Once the master completes transmitting its conversion data, its FSO goes high and triggers the slave's FSI to begin its data transmission frame.

Serial Interfacing to DSPs

In serial mode, the AD7722 can be interfaced directly to several industry standard DSPs. In all cases, the AD7722 operates as the master with the DSP operating as the slave. The AD7722 outputs its own serial clock (SCO) to transmit the digital word on the SDO pin to a DSP. The DSP's serial interface is synchronized to the data transmission provided by the FSO signal.

Since the serial data clock from the AD7722 is always one-half the CLKIN frequency, DSPs that can accept relatively high serial clock frequencies are required. The ADSP-21xx family of DSPs can operate with a maximum serial clock of 13.824 MHz; the DSP56002 allows a maximum serial clock of 13.3 MHz; while the TMS320C5x-57 accepts a maximum serial clock of 10.989 MHz. To interface the AD7722 to other DSPs, the master clock frequency of the AD7722 can be reduced so that the SCO frequency equals the maximum allowable frequency of the serial clock input to the DSP. When the AD7722 is operated with a lower CLKIN frequency (< 10 MHz), DSPs such as the TMS320C20/C25 and DSP56000/1 can be used.

Figures 41 to 43 show the interfaces between the AD7722 and several DSPs. In all cases, the interface control pins, TSI, DOE, SFMT, CFMT, SYNC, and FSI can be permanently hardwired together to either DGND or DVDD. Alternatively, SFMT or CFMT can be tied either high or low to configure the serial data interface for the particular format required by the DSP. The frame synchronization signal, FSI, can be applied from the user's system control logic.

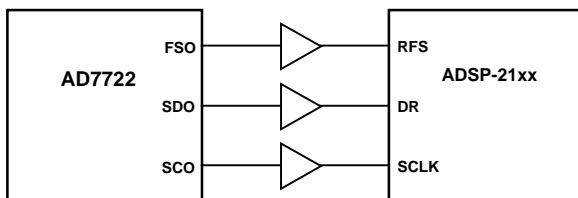

Figure 41. AD7722 to ADSP-21xx Interface

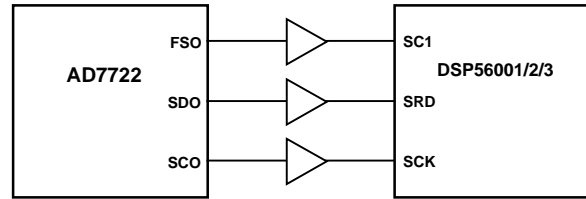

Figure 42. AD7722 to DSP56000 Interface

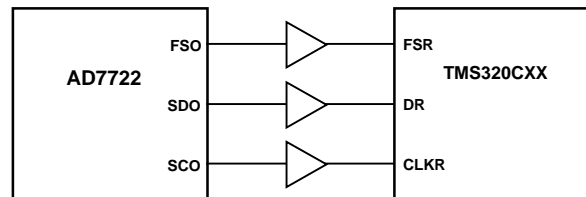

Figure 43. AD7722 to TMS320C20/25/50 Interface

Grounding and Layout

The analog and digital power supplies to the AD7722 are independent and separately pinned out to minimize coupling between analog and digital sections within the device. The AD7722 should be treated as an analog component and grounded and decoupled to the analog ground plane. All the AD7722 ground pins should be soldered directly to a ground plane to minimize series inductance. All converter power pins should be decoupled to the analog ground plane. To achieve the best decoupling, place surface mount capacitors as close as possible to the device, ideally right up against the device pins.

The printed circuit board that houses the AD7722 should use separate ground planes for the analog and the digital interface circuitry. All converter power pins should be decoupled to the analog ground plane, and all interface logic circuit power pins should be decoupled to the digital ground plane. This facilitates the use of ground planes, which can physically separate sensitive analog components from the noisy digital system. Digital and analog ground planes should only be joined in one place and should not overlap to minimize capacitive coupling between them.

Separate power supplies for AVDD and DVDD are also highly desirable. The digital supply pin DVDD should be powered from a separate analog supply, but if necessary DVDD may share its power connection to AVDD. Refer to the connection diagram (Figure 44). The 10 Ω resistor, in series with the DVDD pin, is required to dampen the effects of the fast switching currents into the digital section of the AD7722. The ferrite is also recommended to filter high frequency signals from corrupting the analog power supply.

A minimum etch technique is generally best for ground planes because it gives the best shielding. Noise can be minimized by paying attention to the system layout and preventing different signals from interfering with each other. High level analog signals should be separated from low level analog signals, and both should be kept away from digital signals. In waveform sampling and reconstruction systems, the sampling clock (CLKIN) is as vulnerable to noise as any analog signal. CLKIN should be isolated from the analog and digital systems. Fast switching signals like clocks should be shielded with their associated ground to avoid radiating noise to other sections of the board, and clock signals should never be routed near the analog inputs.

Avoid running digital lines under the device as these will couple noise onto the die. The analog ground plane should be allowed to run under the AD7722 to shield it from noise coupling. The power supply lines to the AD7722 should use as large a trace as possible (preferably a plane) to provide a low impedance path and reduce the effects of glitches on the power supply line. Avoid crossover of digital and analog signals. Traces on opposite

sides of the board should run at right angles to each other. This will reduce the effects of feedthrough through the board.

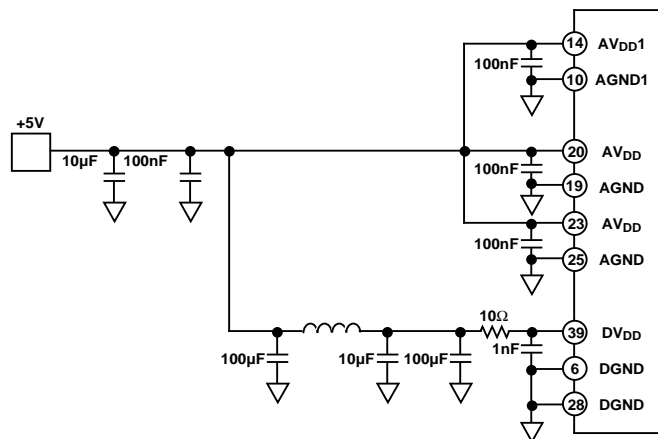
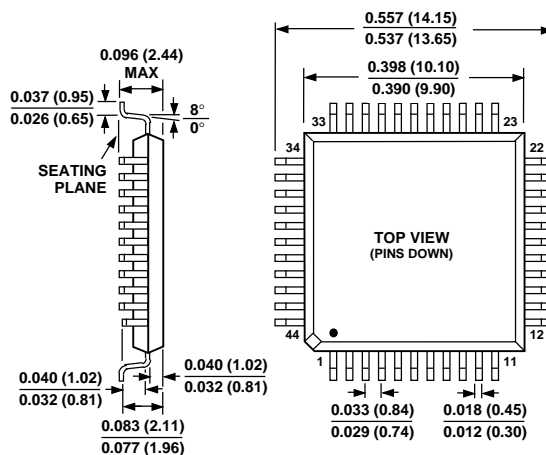

Figure 44. Power Supply Decoupling

OUTLINE DIMENSIONS

Dimensions shown in inches and (mm).

44-Pin PQFP (S-44)





LittleDiode supplies new, hard to find or obsolete electronic components and semiconductors all over the world.

With over two million different components listed you are sure to find the part you need.

Feel free to visit us today at our online store:

LittleDiode.com

Looking forward to providing you with the best possible service.