

FEATURES

- 4-Wire Touch Screen Interface
- Specified Throughput Rate of 125 kSPS
- Low Power Consumption:
 - 1.37 mW Max at 125 kSPS with $V_{CC} = 3.6\text{ V}$
- Single Supply, V_{CC} of 2.2 V to 5.25 V
- Ratiometric Conversion
- High-Speed Serial Interface
- Programmable 8- or 12-Bit Resolution
- Two Auxiliary Analog Inputs
- Shutdown Mode: $1\ \mu\text{A}$ max
- 16-Lead QSOP and TSSOP Packages

APPLICATIONS

- Personal Digital Assistants
- Smart Hand-Held Devices
- Touch Screen Monitors
- Point-of-Sales Terminals
- Pagers

GENERAL DESCRIPTION

The AD7843 is a 12-bit successive-approximation ADC with a synchronous serial interface and low on resistance switches for driving touch screens. The part operates from a single 2.2 V to 5.25 V power supply and features throughput rates greater than 125 kSPS.

The external reference applied to the AD7843 can be varied from 1 V to $+V_{CC}$, while the analog input range is from 0 V to V_{REF} . The device includes a shutdown mode that reduces the current consumption to less than $1\ \mu\text{A}$.

The AD7843 features on-board switches. This coupled with low power and high-speed operation make this device ideal for battery-powered systems such as personal digital assistants with resistive touch screens and other portable equipment. The part is available in a 16-lead 0.15" Quarter Size Outline (QSOP) package and a 16-lead Thin Shrink Small Outline (TSSOP) package.

FUNCTIONAL BLOCK DIAGRAM

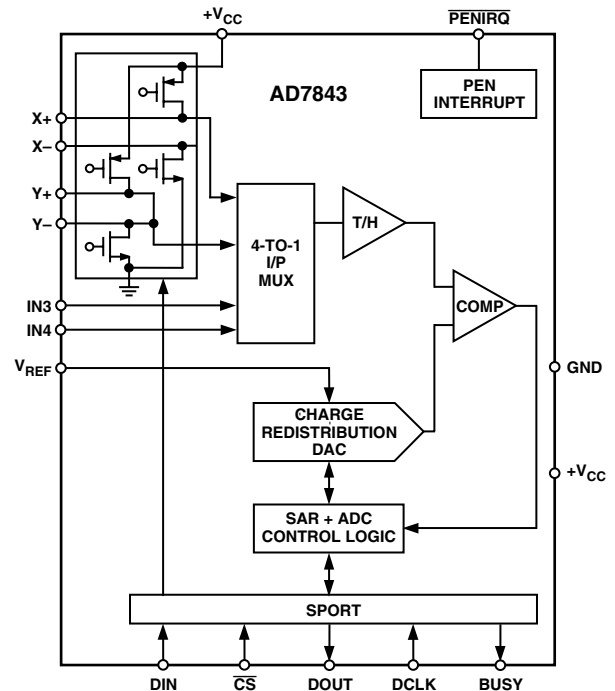

PRODUCT HIGHLIGHTS

1. Ratiometric conversion mode available eliminating errors due to on-board switch resistances.
2. Maximum current consumption of $380\ \mu\text{A}$ while operating at 125 kSPS.
3. Power-down options available.
4. Analog input range from 0 V to V_{REF} .
5. Versatile serial I/O port.

REV. 0

Information furnished by Analog Devices is believed to be accurate and reliable. However, no responsibility is assumed by Analog Devices for its use, nor for any infringements of patents or other rights of third parties which may result from its use. No license is granted by implication or otherwise under any patent or patent rights of Analog Devices.

AD7843—SPECIFICATIONS ($V_{CC} = 2.7\text{ V to }3.6\text{ V}$, $V_{REF} = 2.5\text{ V}$, $f_{SCLK} = 2\text{ MHz}$ unless otherwise noted; $T_A = -40^\circ\text{C to }+85^\circ\text{C}$, unless otherwise noted.)

Parameter	AD7843A ¹	Unit	Test Conditions/Comments
DC ACCURACY			
Resolution	12	Bits	$V_{CC} = 2.7\text{ V}$
No Missing Codes	11	Bits min	
Integral Nonlinearity ²	± 2	LSB max	
Offset Error ²	± 6	LSB max	
Offset Error Match ³	1	LSB max	
	0.1	LSB typ	
Gain Error ²	± 4	LSB max	
Gain Error Match ³	1	LSB max	
	0.1	LSB typ	
Power Supply Rejection	70	dB typ	
SWITCH DRIVERS			
On-Resistance ²			
Y+, X+	5	Ω typ	
Y-, X-	6	Ω typ	
ANALOG INPUT			
Input Voltage Ranges	0 to V_{REF}	Volts	
DC Leakage Current	± 0.1	μA typ	
Input Capacitance	37	pF typ	
REFERENCE INPUT			
V_{REF} Input Voltage Range	1.0/+ V_{CC}	V min/max	$\overline{CS} = \text{GND or } +V_{CC}$ 8 μA typ $f_{SAMPLE} = 12.5\text{ kHz}$ $CS = +V_{CC}$; 0.001 μA typ
DC Leakage Current	± 1	μA max	
V_{REF} Input Impedance	5	$\text{G}\Omega$ typ	
V_{REF} Input Current ³	20	μA max	
	1	μA typ	
	1	μA max	
LOGIC INPUTS			
Input High Voltage, V_{INH}	2.4	V min	Typically 10 nA, $V_{IN} = 0\text{ V or } +V_{CC}$
Input Low Voltage, V_{INL}	0.4	V max	
Input Current, I_{IN}	± 1	μA max	
Input Capacitance, C_{IN} ⁴	10	pF max	
LOGIC OUTPUTS			
Output High Voltage, V_{OH}	$V_{CC} - 0.2$	V min	$I_{SOURCE} = 250\ \mu\text{A}$; $V_{CC} = 2.2\text{ V to }5.25\text{ V}$ $I_{SINK} = 250\ \mu\text{A}$ $I_{SINK} = 250\ \mu\text{A}$; 100 k Ω Pull-Up
Output Low Voltage, V_{OL}	0.4	V max	
\overline{PENIRQ} Output Low Voltage, V_{OL}	0.4	V max	
Floating-State Leakage Current	± 10	μA max	
Floating-State Output Capacitance ⁴	10	pF max	
Output Coding	Straight (Natural) Binary		
CONVERSION RATE			
Conversion Time	12	DCLK Cycles max	
Track/Hold Acquisition Time	3	DCLK Cycles min	
Throughput Rate	125	kSPS max	
POWER REQUIREMENTS			
V_{CC} (Specified Performance)	2.7/3.6	V min/max	Functional from 2.2 V to 5.25 V Digital I/Ps = 0 V or V_{CC} $V_{CC} = 3.6\text{ V}$, 240 μA typ $V_{CC} = 2.7\text{ V}$, $f_{DCLK} = 200\text{ kHz}$ $V_{CC} = 3.6\text{ V}$
I_{CC} ⁵			
Normal Mode ($f_{SAMPLE} = 125\text{ kSPS}$)	380	μA max	
Normal Mode ($f_{SAMPLE} = 12.5\text{ kSPS}$)	170	μA typ	
Normal Mode (Static)	150	μA typ	
Shutdown Mode (Static)	1	μA max	
Power Dissipation ⁵			
Normal Mode ($f_{SAMPLE} = 125\text{ kSPS}$)	1.368	mW max	
Shutdown	3.6	μW max	

NOTES

¹Temperature range as follows: A Version: $-40^\circ\text{C to }+85^\circ\text{C}$.

²See Terminology.

³Guaranteed by design.

⁴Sample tested @ 25°C to ensure compliance.

⁵See Power vs. Throughput Rate section.

Specifications subject to change without notice.

TIMING SPECIFICATIONS¹ ($T_A = T_{MIN}$ to T_{MAX} , unless otherwise noted; $V_{CC} = 2.7$ V to 3.6 V, $V_{REF} = 2.5$ V)

Parameter	Limit at T_{MIN} , T_{MAX}	Unit	Description
f_{DCLK} ²	10 2	kHz min MHz max	
t_{ACQ}	1.5	μ s min	Acquisition Time
t_1	10	ns min	\overline{CS} Falling Edge to First DCLK Rising Edge
t_2	60	ns max	\overline{CS} Falling Edge to BUSY Three-State Disabled
t_3 ³	60	ns max	\overline{CS} Falling Edge to DOUT Three-State Disabled
t_4	200	ns min	DCLK High Pulsewidth
t_5	200	ns min	DCLK Low Pulsewidth
t_6	60	ns max	DCLK Falling Edge to BUSY Rising Edge
t_7	10	ns min	Data Setup Time Prior to DCLK Rising Edge
t_8	10	ns min	Data Valid to DCLK Hold Time
t_9 ³	200	ns max	Data Access Time after DCLK Falling Edge
t_{10}	0	ns min	\overline{CS} Rising Edge to DCLK Ignored
t_{11}	200	ns max	\overline{CS} Rising Edge to BUSY High Impedance
t_{12} ⁴	200	ns max	\overline{CS} Rising Edge to DOUT High Impedance

NOTES

¹Sample tested at 25°C to ensure compliance. All input signals are specified with $t_r = t_f = 5$ ns (10% to 90% of V_{CC}) and timed from a voltage level of 1.6 V.

²Mark/Space ratio for the SCLK input is 40/60 to 60/40.

³Measured with the load circuit of Figure 1 and defined as the time required for the output to cross 0.4 V or 2.0 V.

⁴ t_{12} is derived from the measured time taken by the data outputs to change 0.5 V when loaded with the circuit of Figure 1. The measured number is then extrapolated back to remove the effects of charging or discharging the 50 pF capacitor. This means that the time, t_{12} , quoted in the timing characteristics is the true bus relinquish time of the part and is independent of the bus loading.

Specifications subject to change without notice.

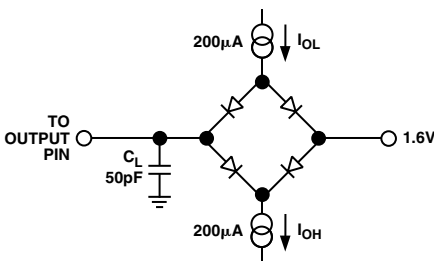

Figure 1. Load Circuit for Digital Output Timing Specifications

AD7843

ABSOLUTE MAXIMUM RATINGS¹

(T_A = 25°C unless otherwise noted)

+V _{CC} to GND	−0.3 V to +7 V
Analog Input Voltage to GND	−0.3 V to V _{CC} + 0.3 V
Digital Input Voltage to GND	−0.3 V to V _{CC} + 0.3 V
Digital Output Voltage to GND	−0.3 V to V _{CC} + 0.3 V
V _{REF} to GND	−0.3 V to V _{CC} + 0.3 V
Input Current to Any Pin Except Supplies ²	±10 mA
Operating Temperature Range	
Commercial	−40°C to +85°C
Storage Temperature Range	−65°C to +150°C
Junction Temperature	150°C

QSOP, TSSOP Package, Power Dissipation	450 mW
θ _{JA} Thermal Impedance	149.97°C/W (QSOP)
	150.4°C/W (TSSOP)
θ _{JC} Thermal Impedance	38.8°C/W (QSOP)
	27.6°C/W (TSSOP)
Lead Temperature, Soldering	
Vapor Phase (60 secs)	215°C
Infrared (15 secs)	220°C

NOTES

¹Stresses above those listed under Absolute Maximum Rating may cause permanent damage to the device. This is a stress rating only; functional operation of the device at these or any other conditions above those listed in the operational sections of this specification is not implied. Exposure to absolute maximum rating conditions for extended periods may affect device reliability.

²Transient currents of up to 100 mA will not cause SCR latch-up.

ORDERING GUIDE

Model	Temperature Range	Linearity Error (LSB) ¹	Package Option	Package Description	Branding Information
AD7843ARQ	−40°C to +85°C	±2	RQ-16 ²	QSOP	AD7843ARQ
AD7843ARQ-REEL	−40°C to +85°C	±2	RQ-16 ²	QSOP	AD7843ARQ
AD7843ARQ-REEL7	−40°C to +85°C	±2	RQ-16 ²	QSOP	AD7843ARQ
AD7843ARU	−40°C to +85°C	±2	RU-16	TSSOP	AD7843ARU
AD7843ARU-REEL	−40°C to +85°C	±2	RU-16	TSSOP	AD7843ARU
AD7843ARU-REEL7	−40°C to +85°C	±2	RU-16	TSSOP	AD7843ARU
EVAL-AD7843CB ³	Evaluation Board				
EVAL-CONTROL BRD ⁴	Controller Board				

NOTES

¹Linearity error here refers to integral linearity error.

²RQ = 0.15" Quarter Size Outline Package.

³This can be used as a stand-alone evaluation board or in conjunction with the EVALUATION BOARD CONTROLLER for evaluation/demonstration purposes.

⁴This EVALUATION BOARD CONTROLLER is a complete unit allowing a PC to control and communicate with all Analog Devices evaluation boards ending in the CB designators.

CAUTION

ESD (electrostatic discharge) sensitive device. Electrostatic charges as high as 4000 V readily accumulate on the human body and test equipment and can discharge without detection. Although the AD7843 features proprietary ESD protection circuitry, permanent damage may occur on devices subjected to high-energy electrostatic discharges. Therefore, proper ESD precautions are recommended to avoid performance degradation or loss of functionality.



PIN CONFIGURATION QSOP/TSSOP

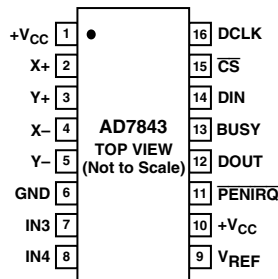

PIN FUNCTION DESCRIPTIONS

Pin No.	Mnemonic	Function
1, 10	+V _{CC}	Power Supply Input. The +V _{CC} range for the AD7843 is from 2.2 V to 5.25 V. Both +V _{CC} pins should be connected directly together.
2	X+	X+ Position Input. ADC Input Channel 1.
3	Y+	Y+ Position Input. ADC Input Channel 2.
4	X-	X- Position Input.
5	Y-	Y- Position Input.
6	GND	Analog Ground. Ground reference point for all circuitry on the AD7843. All analog input signals and any external reference signal should be referred to this GND voltage.
7	IN3	Auxiliary Input 1. ADC Input Channel 3.
8	IN4	Auxiliary Input 2. ADC Input Channel 4.
9	V _{REF}	Reference Input for the AD7843. An external reference must be applied to this input. The voltage range for the external reference is 1.0 V to +V _{CC} . For specified performance it is 2.5 V.
11	$\overline{\text{PENIRQ}}$	Pen Interrupt. CMOS Logic open drain output (requires 10 k Ω to 100 k Ω pull-up resistor externally).
12	DOUT	Data Out. Logic Output. The conversion result from the AD7843 is provided on this output as a serial data stream. The bits are clocked out on the falling edge of the DCLK input. This output is high impedance when $\overline{\text{CS}}$ is high.
13	BUSY	BUSY Output. Logic Output. This output is high impedance when $\overline{\text{CS}}$ is high.
14	DIN	Data In. Logic Input. Data to be written to the AD7843's Control Register is provided on this input and is clocked into the register on the rising edge of DCLK (see Control Register section).
15	$\overline{\text{CS}}$	Chip Select Input. Active Low Logic Input. This input provides the dual function of initiating conversions on the AD7843 and also enables the serial input/output register.
16	DCLK	External Clock Input. Logic Input. DCLK provides the serial clock for accessing data from the part. This clock input is also used as the clock source for the AD7843's conversion process.

TERMINOLOGY**Integral Nonlinearity**

This is the maximum deviation from a straight line passing through the endpoints of the ADC transfer function. The endpoints of the transfer function are zero scale, a point 1 LSB below the first code transition, and full scale, a point 1 LSB above the last code transition.

Differential Nonlinearity

This is the difference between the measured and the ideal 1 LSB change between any two adjacent codes in the ADC.

Offset Error

This is the deviation of the first code transition (00 . . . 000) to (00 . . . 001) from the ideal, i.e., AGND + 1 LSB.

Gain Error

This is the deviation of the last code transition (111 . . . 110) to (111 . . . 111) from the ideal (i.e., V_{REF} - 1 LSB) after the offset error has been adjusted out.

Track/Hold Acquisition Time

The track/hold amplifier enters the acquisition phase on the fifth falling edge of DCLK after the START bit has been detected. Three DCLK cycles are allowed for the Track/Hold acquisition time and the input signal will be fully acquired to the 12-bit level within this time even with the maximum specified DCLK frequency. See Analog Input section for more details.

On-Resistance

This is a measure of the ohmic resistance between the drain and source of the switch drivers.

AD7843—Typical Performance Characteristics

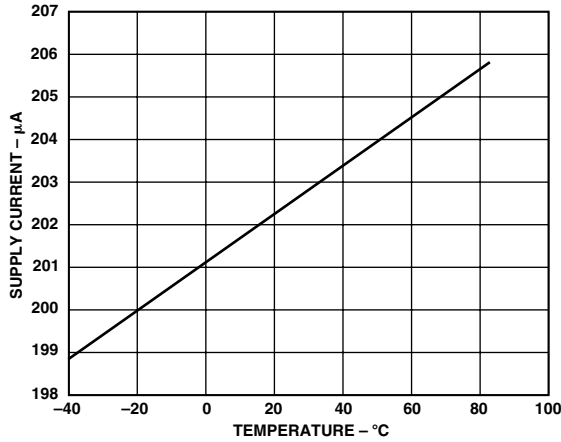

TPC 1. Supply Current vs. Temperature

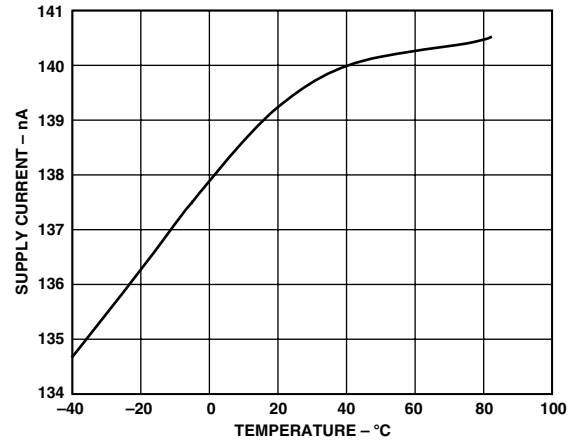

TPC 4. Power-Down Supply Current vs. Temperature

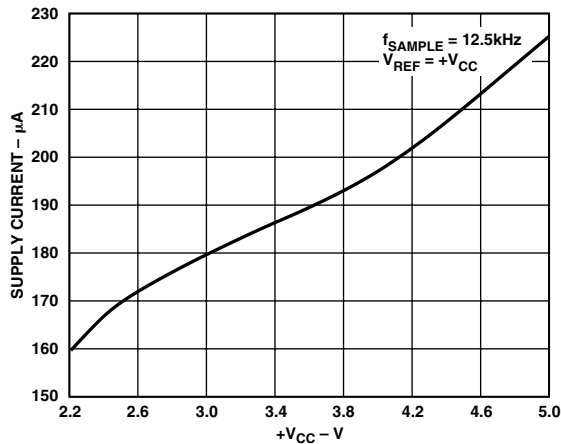

TPC 2. Supply Current vs. +V_{CC}

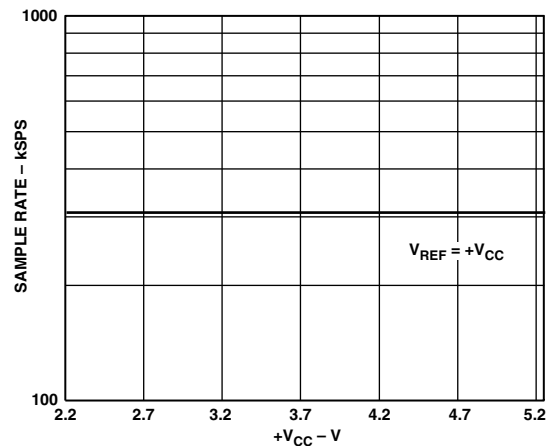

TPC 5. Maximum Sample Rate vs. +V_{CC}

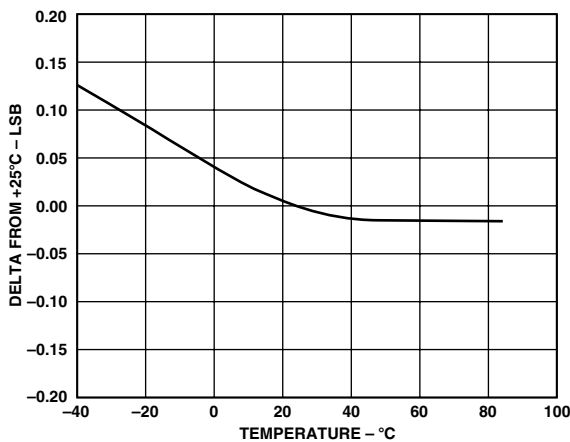

TPC 3. Change in Gain vs. Temperature

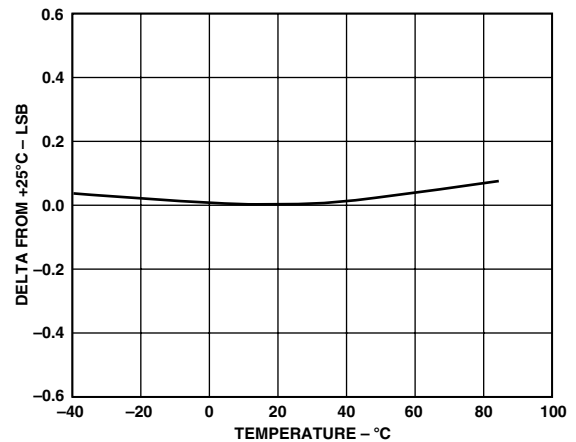

TPC 6. Change in Offset vs. Temperature

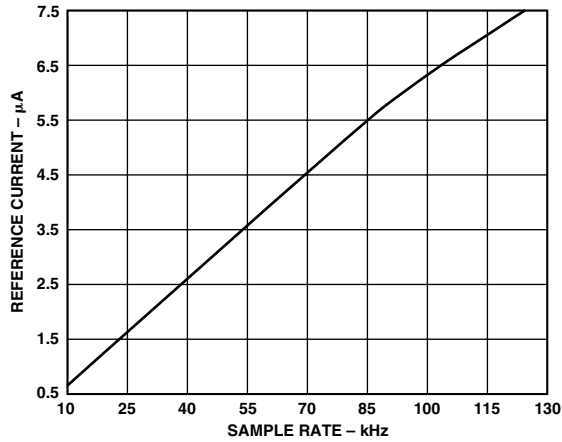

TPC 7. Reference Current vs. Sample Rate

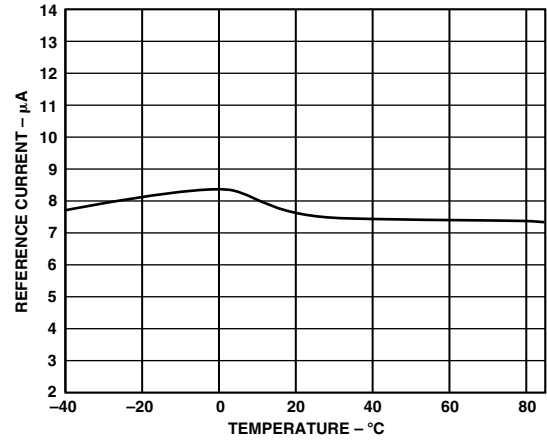

TPC 10. Reference Current vs. Temperature

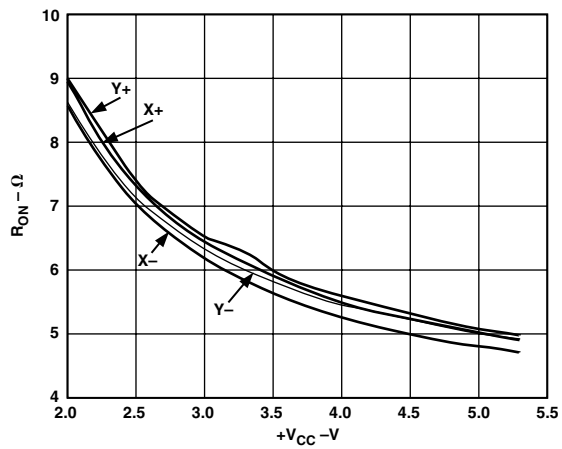

TPC 8. Switch-On-Resistance vs. +VCC (X+, Y+: +VCC to Pin; X-, Y-: Pin to GND)

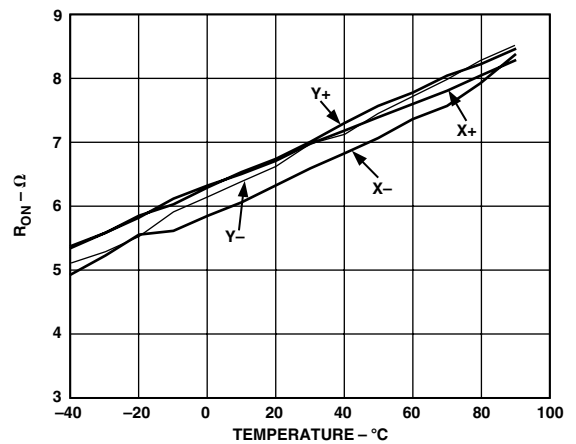

TPC 11. Switch-On-Resistance vs. Temperature (X+, Y+: +VCC to Pin; X-, Y-: Pin to GND)

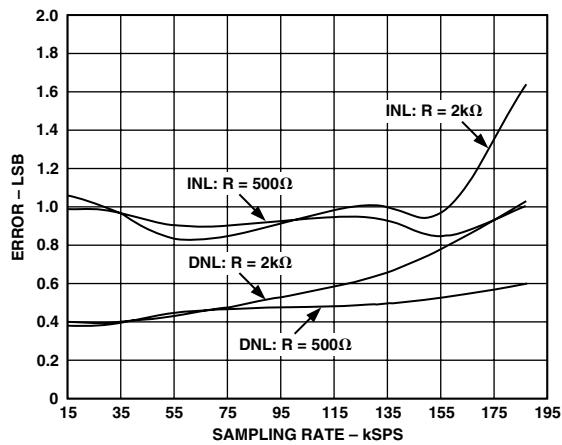

TPC 9. Maximum Sampling Rate vs. R_{IN}

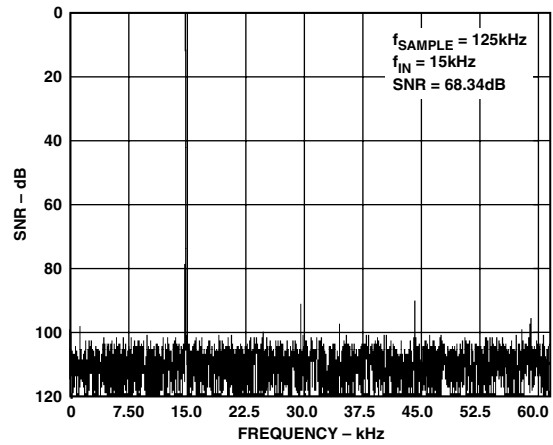

TPC 12. Auxiliary Channel Dynamic Performance

AD7843

TPC 12 shows a typical FFT plot for the auxiliary channels of the AD7843 at 125 kHz sample rate and 15 kHz input frequency.

TPC 13 shows the power supply rejection ratio versus V_{CC} supply frequency for the AD7843. The power supply rejection ratio is defined as the ratio of the power in the ADC output at full-scale frequency f_s to the power of a 100 mV sine wave applied to the ADC V_{CC} supply of frequency f_s :

$$PSRR \text{ (dB)} = 10 \log (P_f/P_{f_s})$$

P_f = Power at frequency f in ADC output, P_{f_s} = power at frequency f_s coupled onto the ADC V_{CC} supply. Here a 100 mV peak-to-peak sine wave is coupled onto the V_{CC} supply. Decoupling capacitors of 10 μF and 0.1 μF were used on the supply.

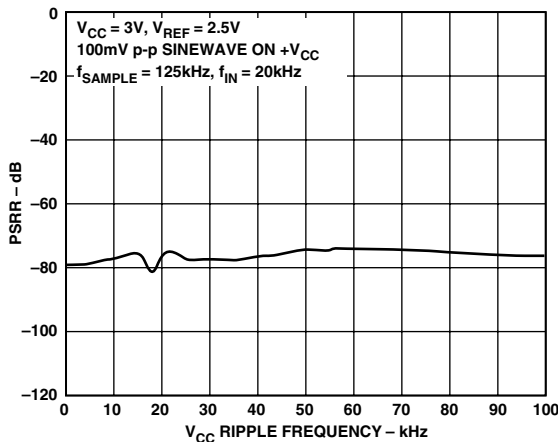

TPC 13. AC PSRR vs. Supply Ripple Frequency

CIRCUIT INFORMATION

The AD7843 is a fast, low-power, 12-bit, single supply, A/D converter. The AD7843 can be operated from a 2.2 V to 5.25 V supply. When operated from either a 5 V supply or a 3 V supply, the AD7843 is capable of throughput rates of 125 kSPS when provided with a 2 MHz clock.

The AD7843 provides the user with an on-chip track/hold, multiplexer, A/D converter, and serial interface housed in a tiny 16-lead QSOP or TSSOP package, which offers the user considerable space-saving advantages over alternative solutions. The serial clock input (DCLK) accesses data from the part but also provides the clock source for the successive-approximation A/D

converter. The analog input range is 0 V to V_{REF} (where the externally-applied V_{REF} can be between 1 V and V_{CC}).

The analog input to the ADC is provided via an on-chip multiplexer. This analog input may be any one of the X and Y panel coordinates. The multiplexer is configured with low resistance switches that allow an unselected ADC input channel to provide power and an accompanying pin to provide ground for an external device. For some measurements the on-resistance of the switches may present a source of error. However, with a differential input to the converter and a differential reference architecture this error can be negated.

ADC TRANSFER FUNCTION

The output coding of the AD7843 is straight binary. The designed code transitions occur at successive integer LSB values (i.e., 1 LSB, 2 LSBs, etc.). The LSB size is $= V_{REF}/4096$. The ideal transfer characteristic for the AD7843 is shown in Figure 2 below.

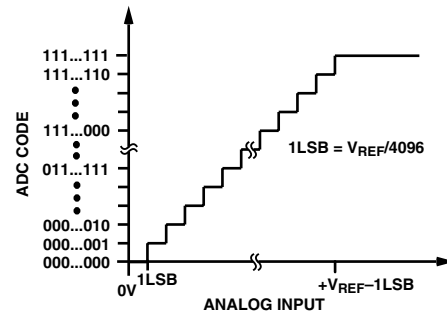

Figure 2. AD7843 Transfer Characteristic

TYPICAL CONNECTION DIAGRAM

Figure 3 shows a typical connection diagram for the AD7843 in a touch screen control application. The AD7843 requires an external reference and an external clock. The external reference can be any voltage between 1 V and V_{CC} . The value of the reference voltage will set the input range of the converter. The conversion result is output MSB first followed by the remaining eleven bits and three trailing zeroes depending on the number of clocks used per conversion, see the Serial Interface section. For applications where power consumption is of concern, the power management option should be used to improve power performance. See Table III for the available power management options.

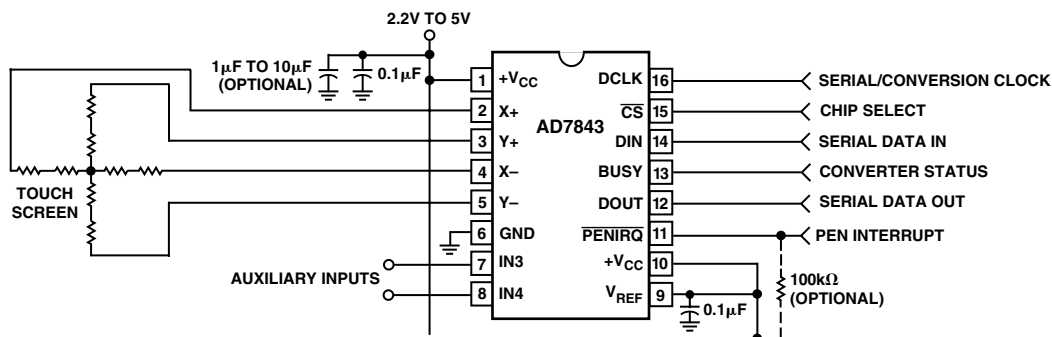

Figure 3. Typical Application Circuit

ANALOG INPUT

Figure 4 shows an equivalent circuit of the analog input structure of the AD7843 which contains a block diagram of the input multiplexer, the differential input of the A/D converter and the differential reference.

Table I shows the multiplexer address corresponding to each analog input, both for the $\overline{\text{SER/DFR}}$ bit in the control register set high and low. The control bits are provided serially to the device via the DIN pin. For more information on the control register see the Control Register section.

When the converter enters the hold mode, the voltage difference between the +IN and -IN inputs (see Figure 4) is captured on the internal capacitor array. The input current on the analog inputs depends on the conversion rate of the device. During the sample period, the source must charge the internal sampling capacitor (typically 37 pF). Once the capacitor has been fully charged, there is no further input current. The rate of charge transfer from the analog source to the converter is a function of conversion rate.

Acquisition Time

The track and hold amplifier enters its tracking mode on the falling edge of the fifth DCLK after the START bit has been detected (see Figure 13). The time required for the track and hold amplifier to acquire an input signal will depend how quickly the 37 pF input capacitance is charged. With zero source impedance on the analog input three DCLK cycles will always be sufficient to acquire the signal to the 12-bit level. With a source impedance R_{IN} on the analog input, the actual acquisition time required is calculated using the formula:

$$t_{ACQ} = 8.4 \times (R_{IN} + 100 \Omega) \times 37 \text{ pF}$$

where R_{IN} is the source impedance of the input signal, and 100 Ω , 37 pF is the input RC value. Depending on the frequency of DCLK used, three DCLK cycles may or may not be sufficient to acquire the analog input signal with various source impedance values.

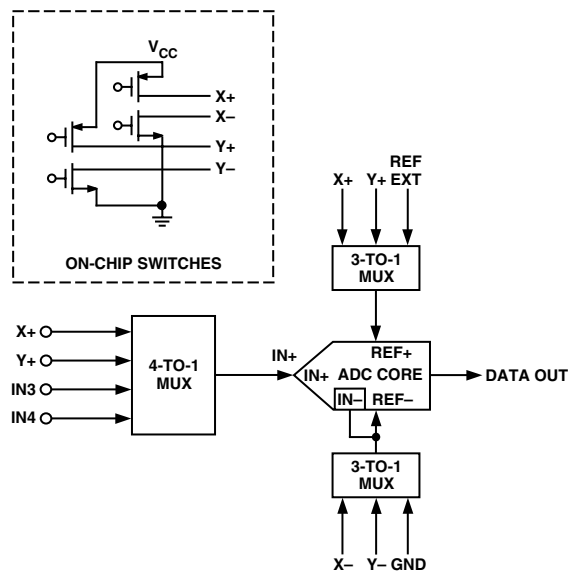

Figure 4. Equivalent Analog Input Circuit

Table I. Analog Input, Reference, and Touch Screen Control

A2 ¹	A1 ¹	A0 ¹	SER/DFR	Analog In	X Switches	Y Switches	+REF ²	-REF ²	
0	0	1	1	X+	OFF	ON	V _{REF}	GND	
0	1	0	1	IN3	OFF	OFF	V _{REF}	GND	
1	0	1	1	Y+	ON	OFF	V _{REF}	GND	
1	1	0	1	IN4	OFF	OFF	V _{REF}	GND	
0	0	1	0	X+	OFF	ON	Y+	Y-	
1	0	1	0	Y+	ON	OFF	X+	X-	
1	1	0	0	Outputs Identity Code, 1000 0000 0000					

NOTES

¹All remaining configurations are invalid addresses.

²Internal node – not directly accessible by the user.

Touch Screen Settling

In some applications, external capacitors may be required across the touch screen to filter noise associated with it, e.g., noise generated by the LCD panel or backlight circuitry. The value of these capacitors will cause a settling time requirement when the panel is touched. The settling time will typically show up as a gain error. There are several methods for minimizing or eliminating this issue. The problem may be that the input signal, or reference, or both, have not settled to their final value before the sampling instant of the ADC. Additionally, the reference voltage may still be changing during the conversion cycle. One option is to stop, or slow down the DCLK for the required touch screen settling time. This will allow the input and reference to stabilize for the acquisition time. This will resolve the issue for both single-ended and differential modes.

The other option is to operate the AD7843 in differential mode only for the touch screen, and program the AD7843 to keep the touch screen drivers ON and not go into power-down (PD0 = PD1 = 1). Several conversions may be required depending on the settling time required and the AD7843 data rate. Once the required number of conversions have been made, the AD7843 can then be placed in a power-down state on the last measurement. The last method is to use the 15 DCLK cycle mode, which maintains the touch screen drivers ON until it is commanded to stop by the processor.

Reference Input

The voltage difference between +REF and -REF (see Figure 4) sets the analog input range. The AD7843 will operate with a reference input in the range of 1 V to V_{CC}. The voltage into the V_{REF} input is not buffered and directly drives the capacitor DAC portion of the AD7843. Figure 5 shows the reference input circuitry. Typically, the input current is 8 μA with V_{REF} = 2.5 V and f_{SAMPLE} = 125 kHz. This value will vary by a few microamps, depending on the result of the conversion. The reference current diminishes directly with both conversion rate and reference voltage. As the current from the reference is drawn on each bit decision, clocking the converter more quickly during a given conversion period will not reduce the overall current drain from the reference.

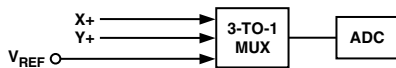

Figure 5. Reference Input Circuitry

When making touch screen measurements, conversions can be made in the differential (ratiometric) mode or the single-ended mode. If the SER/DFR bit is set to 1 in the control register, a single-ended conversion will be performed. Figure 6 shows the configuration for a single-ended Y coordinate measurement. The X+ input is connected to the analog to digital converter, the Y+ and Y- drivers are turned on and the voltage on X+ is digitized. The conversion is performed with the ADC referenced from GND to V_{REF}. The advantage of this mode is that the switches that supply the external touch screen can be turned off once the acquisition is complete, resulting in a power saving. However, the on-resistance of the Y drivers will affect the input voltage that can be acquired. The full touch screen resistance may be in the order of 200 Ω to 900 Ω, depending on the manufacturer. Thus if the on-resistance of the switches is approximately 6 Ω, true full-scale and zero-scale voltages cannot be acquired regardless of where the pen/stylus is on the touch screen.

Note: The minimum touch screen resistance recommended for use with the AD7843 is approximately 70 Ω.

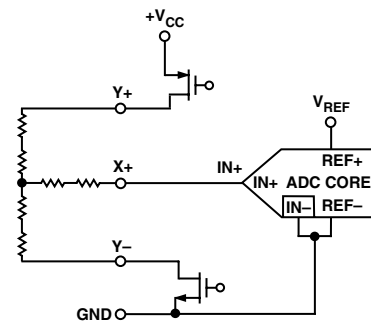

Figure 6. Single-Ended Reference Mode (SER/DFR = 1)

In this mode of operation, therefore, some voltage is likely to be lost across the internal switches and, in addition to this, it is unlikely that the internal switch resistance will track the resistance of the touch screen over temperature and supply, providing an additional source of error.

The alternative to this situation is to set the SER/DFR bit low. If one again considers making a Y coordinate measurement, but now the +REF and -REF nodes of the ADC are connected directly to the Y+ and Y- pins, this means the analog to digital conversion will be ratiometric. The result of the conversion will always be a percentage of the external resistance, independent of how it may change with respect to the on-resistance of the internal switches. Figure 7 shows the configuration for a ratiometric Y coordinate measurement. It should be noted that the differential

reference mode can only be used with $+V_{CC}$ as the source of the $+REF$ voltage and cannot be used with V_{REF} .

The disadvantage of this mode of operation is that during both the acquisition phase and conversion process, the external touch screen must remain powered. This will result in additional supply current for the duration of the conversion.

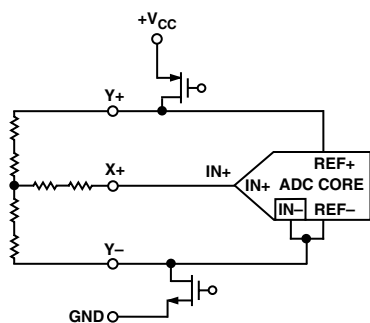

Figure 7. Differential Reference Mode ($SER/DFR = 0$)

CONTROL REGISTER

The control word provided to the ADC via the DIN pin is shown in Table II. This provides the conversion start, channel addressing, ADC conversion resolution, configuration and power-down of the AD7843. Table II provides detailed information on the order and description of these control bits within the control word.

Initiate START

The first bit, the “S” bit, must always be set to 1 to initiate the start of the control word. The AD7843 will ignore any inputs on the DIN line until the start bit is detected.

Channel Addressing

The next three bits in the control register, A2, A1 and A0, select the active input channel(s) of the input multiplexer (see Table I and Figure 4), touch screen drivers, and the reference inputs.

MODE

The MODE bit sets the resolution of the analog to digital converter. With a 0 in this bit the following conversion will have 12 bits of resolution. With a 1 in this bit the following conversion will have 8 bits of resolution.

SER/DFR

The SER/DFR bit controls the reference mode which can be either single ended or differential if a 1 or a 0 is written to this bit respectively. The differential mode is also referred to as the ratiometric conversion mode. This mode is optimum for X-Position and Y-Position measurements. The reference is derived from the voltage at the switch drivers, which is almost the same as the voltage to the touch screen. In this case a separate reference voltage is not needed as the reference voltage to the analog to digital converter is the voltage across the touch screen. In the single-ended mode, the reference voltage to the converter is always the difference between the V_{REF} and GND pins. See Table I and Figures 4 through 7 for further information.

As the supply current required by the device is so low, a precision reference can be used as the supply source to the AD7843. It may also be necessary to power the touch screen from the reference, which may require 5 mA to 10 mA. A REF19x voltage reference can source up to 30 mA and, as such, could supply both the ADC and the touch screen. Care must be taken, however, to ensure that the input voltage applied to the ADC does not exceed the reference voltage and hence the supply voltage. See Maximum Ratings section.

NOTE: The differential mode can only be used for X-Position and Y-Position measurements All other measurements require the single-ended mode.

PD0 and PD1

The power management options are selected by programming the power management bits, PD0 and PD1, in the control register. Table III summarizes the available options.

Table II. Control Register Bit Function Description

MSB				LSB			
S	A2	A1	A0	MODE	SER/DFR	PD1	PD0
Bit	Mnemonic	Comment					
7	S	Start Bit. The Control word starts with the first high bit on DIN. A new control word can start every fifteenth DCLK cycle when in the 12-bit conversion mode or every eleventh DCLK cycle when in 8-bit conversion mode.					
6–4	A2–A0	Channel Select Bits. These three address bits along with the SER/DFR bit control the setting of the multiplexer input, switches, and reference inputs, as detailed in Table I.					
3	MODE	12-Bit/8-Bit Conversion Select Bit. This bit controls the resolution of the following conversion. With a 0 in this bit the conversion will have 12-bit resolution or with a 1 in this bit, 8-bit resolution.					
2	SER/DFR	Single-Ended/Differential Reference Select Bit. Along with bits A2–A0, this bit controls the setting of the multiplexer input, switches, and reference inputs as described in Table I.					
1, 0	PD1, PD0	Power Management Bits. These two bits decode the power-down mode of the AD7843 as shown in Table III.					

Table III. Power Management Options

PD1	PD0	$\overline{\text{PENIRQ}}$	Description
0	0	Enabled	This configuration will result in power-down of the device between conversions. The AD7843 will only power down between conversions. Once PD1 and PD0 have been set to 0, 0, the conversion will be performed first and the AD7843 will power down upon completion of that conversion. At the start of the next conversion, the ADC instantly powers up to full power. This means there is no need for additional delays to ensure full operation and the very first conversion is valid. The Y- switch is ON while in power-down.
0	1	Disabled	This configuration will result in the same behavior as when PD1 and PD0 have been programmed with 0, 0, except that $\overline{\text{PENIRQ}}$ is disabled. The Y- switch is OFF while in power-down.
1	0	Enabled	This configuration will result in keeping the AD7843 permanently powered up with the $\overline{\text{PENIRQ}}$ enabled.
1	1	Disabled	This configuration will result in keeping the AD7843 always powered up with the $\overline{\text{PENIRQ}}$ disabled.

POWER VS. THROUGHPUT RATE

By using the power-down options on the AD7843 when not converting, the average power consumption of the device decreases at lower throughput rates. Figure 8 shows how, as the throughput rate is reduced while maintaining the DCLK frequency at 2 MHz, the device remains in its power-down state longer and the average current consumption over time drops accordingly.

For example, if the AD7843 is operated in a 24 DCLK continuous sampling mode, with a throughput rate of 10 kSPS and a SCLK of 2 MHz, the device is placed in the power-down mode between conversions, (PD0, PD1 = 0, 0), the current consumption is calculated as follows. The power dissipation during normal operation is typically 210 μA ($V_{\text{CC}} = 2.7 \text{ V}$). The power-up time of the ADC is instantaneous, so when the part is converting it will consume 210 μA . In this mode of operation the part powers up on the 4th falling edge of DCLK after the start bit has been recognized. It goes back into power-down at the end of conversion on the 20th falling edge of DCLK. This means the part will consume 210 μA for 16 DCLK cycles only, 8 μs , during each conversion cycle. With a throughput rate of 10 kSPS, the cycle time is 100 μs and the average power dissipated during each cycle is $(8/100) \times (210 \mu\text{A}) = 16.8 \mu\text{A}$.

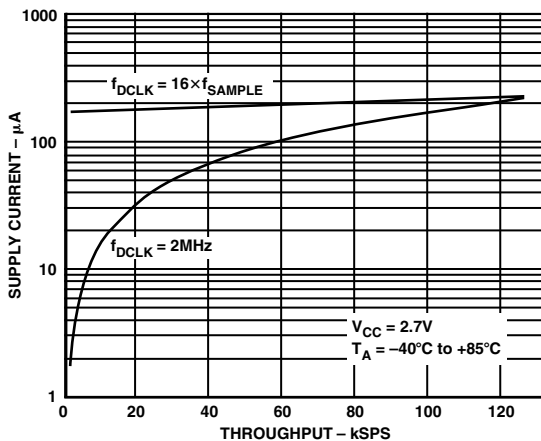

Figure 8. Supply Current vs. Throughput (μA)

SERIAL INTERFACE

Figure 9 shows the typical operation of the serial interface of the AD7843. The serial clock provides the conversion clock and also controls the transfer of information to and from the AD7843. One complete conversion can be achieved with twenty-four DCLK cycles.

The $\overline{\text{CS}}$ signal initiates the data transfer and conversion process. The falling edge of $\overline{\text{CS}}$ takes the BUSY output and the serial bus out of three-state. The first eight DCLK cycles are used to write to the Control Register via the DIN pin. The Control Register is updated in stages as each bit is clocked in and once the converter has enough information about the following conversion to set the input multiplexer and switches appropriately, the converter enters the acquisition mode and if required, the internal switches are turned on. During the acquisition mode the reference input data is updated. After the three DCLK cycles of acquisition, the control word is complete (the power management bits are now updated) and the converter enters the conversion mode. At this point the track and hold goes into hold mode and the input signal is sampled and the BUSY output goes high (BUSY will return low on the next falling edge of DCLK). The internal switches may also turn off at this point if in single-ended mode.

The next 12 DCLK cycles are used to perform the conversion and to clock out the conversion result. If the conversion is ratiometric ($\text{SER}/\overline{\text{DFR}}$ set low) the internal switches are on during the conversion. A thirteenth DCLK cycle is needed to allow the DSP/micro to clock in the LSB. Three more DCLK cycles will clock out the three trailing zeroes and complete the twenty four DCLK transfer. The twenty-four DCLK cycles may be provided from a DSP or via three bursts of eight clock cycles from a microcontroller.

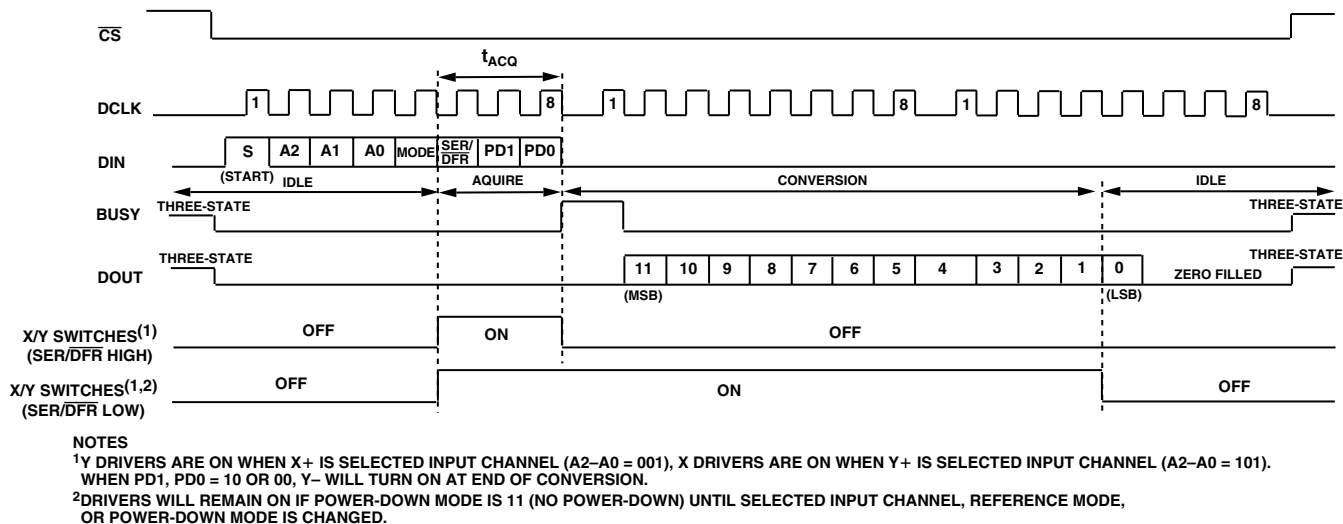

Figure 9. Conversion Timing, 24 DCLKS per Conversion Cycle, 8-Bit Bus Interface. No DCLK delay required with dedicated serial port

Detailed Serial Interface Timing

Figure 10 shows the detailed timing diagram for serial interfacing to the AD7843. Writing of information to the Control Register takes place on the first eight rising edges of DCLK in a data transfer. The Control Register is only written to if a START bit is detected (see Control Register section) on DIN and the initiation of the following conversion is also dependent on the presence of the START bit. Throughout the eight DCLK cycles when data is being written to the part, the DOUT line will be driven low. The MSB of the conversion result is clocked out on the falling edge of the ninth DCLK cycle and is valid on the rising edge of the tenth DCLK cycle, therefore nine leading zeros may be clocked out prior to the MSB. This means the data seen on the DOUT line in the twenty four DCLK conversion cycle, will be presented in the form of nine leading zeros, twelve bits of data and three trailing zeros.

The rising edge of \overline{CS} will put the bus and the BUSY output back into three-state, the DIN line will be ignored and if a conversion is in progress at the time then this will also be aborted. However, if \overline{CS} is not brought high after the completion of the

conversion cycle, then the part will wait for the next START bit to initiate the next conversion. This means each conversion need not necessarily be framed by \overline{CS} , as once \overline{CS} goes low the part will detect each START bit and clock in the control word after it on DIN. When the AD7843 is in the 12-bit conversion mode, a second START bit will not be detected until seven DCLK pulses have elapsed after a control word has been clocked in on DIN, i.e., another START bit can be clocked in on the eighth DCLK rising edge after a control word has been written to the device (see Fifteen Clock Cycle section). If the device is in the 8-bit conversion mode, a second START bit will not be recognized until three DCLK pulses have elapsed after the control word has been clocked in, i.e., another START bit can be clocked in on the fourth DCLK rising edge after a control word has been written to the device.

Because a START bit can be recognized during a conversion, it means the control word for the next conversion can be clocked in during the current conversion, enabling the AD7843 to complete a conversion cycle in less than twenty-four DCLKs.

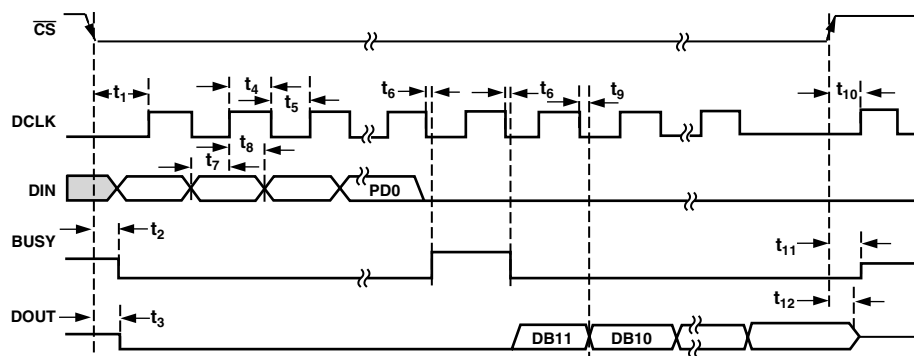

Figure 10. Detailed Timing Diagram

AD7843

Sixteen Clocks per Cycle

The control bits for the next conversion can be overlapped with the current conversion to allow for a conversion every 16 DCLK cycles, as shown in Figure 11. This timing diagram also allows for the possibility of communication with other serial peripherals between each (eight DCLK) byte transfer between the processor and the converter. However, the conversion must be complete within a short enough time frame to avoid capacitive droop effects which may distort the conversion result. It should also be noted that the AD7843 will be fully powered while other serial communications may be taking place between byte transfers.

Fifteen Clocks per Cycle

Figure 12 shows the fastest way to clock the AD7843. This scheme will not work with most microcontrollers or DSPs as in general they are not capable of generating a 15-clock cycle per serial transfer. However, some DSPs will allow the number of clocks per cycle to be programmed and this method could also be used with FPGAs (Field Programmable Gate Arrays) or ASICs (Application Specific Integrated Circuits). As in the 16-clocks-per-cycle case, the control bits for the next conversion are overlapped with the current conversion to allow for a conversion every 15 DCLK cycles, using 12 DCLKs to perform the conversion and three DCLKs to acquire the analog input.

This will effectively increase the throughput rate of the AD7843 beyond that used for the specifications which are tested using 16 DCLKs per cycle, and $DCLK = 2 \text{ MHz}$.

8-Bit Conversion

The AD7843 can be set up to operate in an 8-bit rather than 12-bit mode, by setting the MODE bit to 1 in the control register. This mode allows a faster throughput rate to be achieved, assuming 8-bit resolution is sufficient. When using the 8-bit mode a conversion is complete four clock cycles earlier than in the 12-bit mode. This could be used with serial interfaces that provide 12 clock transfers, or two conversions could be completed with three eight-clock transfers. The throughput rate will increase by 25% as a result of the shorter conversion cycle, but the conversion itself can occur at a faster clock rate because the internal settling time of the AD7843 is not as critical because settling to 8 bits is all that is required. The clock rate can be as much as 50% faster. The faster clock rate and fewer clock cycles combine to provide double the conversion rate.

PEN INTERRUPT REQUEST

The pen interrupt equivalent output circuitry is outlined in Figure 13. By connecting a pull-up resistor (10 k Ω to 100 k Ω) between V_{CC} and this CMOS Logic open drain output, the PENIRQ output will remain high normally. If PENIRQ has

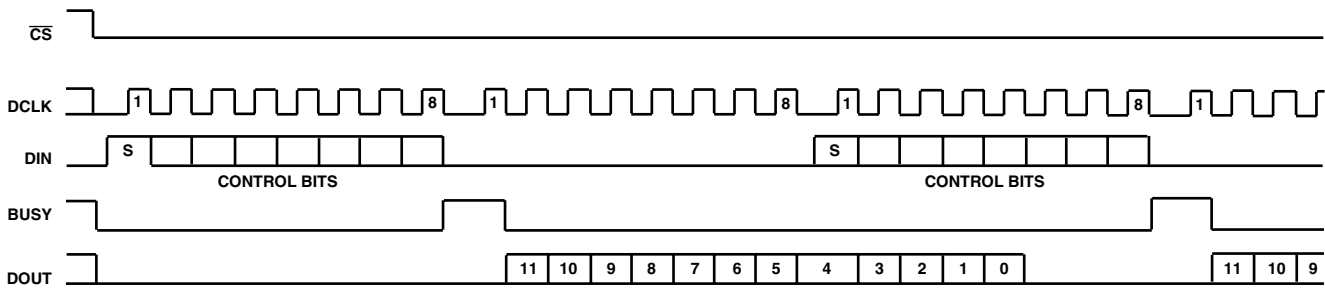

Figure 11. Conversion Timing, 16 DCLKS per Cycle, 8-Bit Bus Interface. No DCLK Delay Required with Dedicated Serial Port

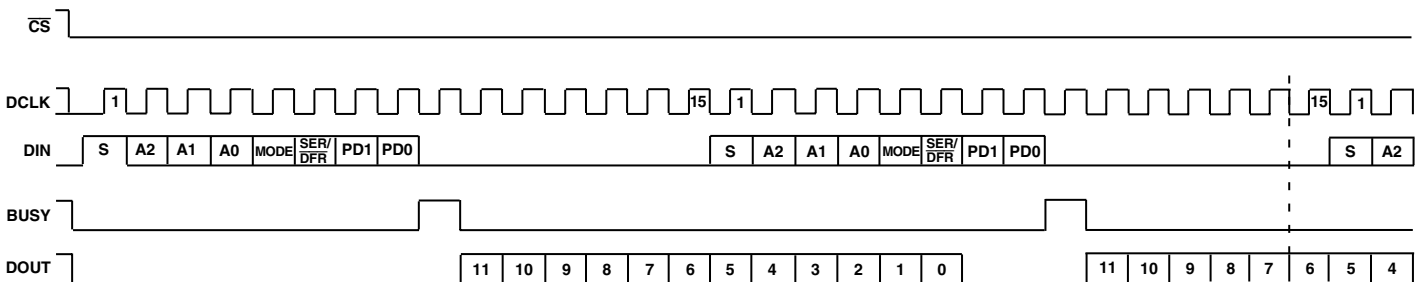

Figure 12. Conversion Timing, 15 DCLKS per Cycle, Maximum Throughput Rate

AD7843

OUTLINE DIMENSIONS

Dimensions shown in inches and (mm).

16-Lead QSOP (RQ-16)

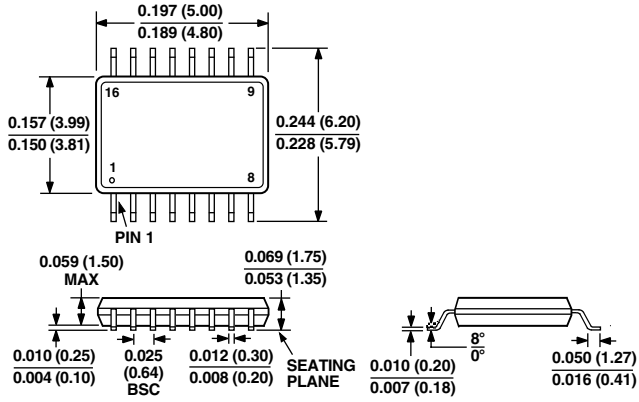

16-Lead TSSOP (RU-16)

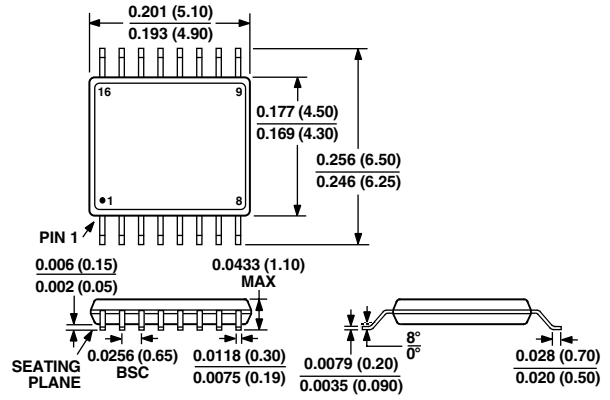



LittleDiode supplies new, hard to find or obsolete electronic components and semiconductors all over the world.

With over two million different components listed you are sure to find the part you need.

Feel free to visit us today at our online store:

LittleDiode.com

Looking forward to providing you with the best possible service.