

### FEATURES

#### High Speed

41 MHz, -3 dB Bandwidth

125 V/ $\mu$ s Slew Rate

80 ns Settling Time

Input Bias Current of 20 pA and Noise Current of  
10 fA/ $\sqrt{\text{Hz}}$

Input Voltage Noise of 12 nV/ $\sqrt{\text{Hz}}$

Fully Specified Power Supplies:  $\pm 5$  V to  $\pm 15$  V

Low Distortion: -76 dB at 1 MHz

High Output Drive Capability

Drives Unlimited Capacitance Load

50 mA Min Output Current

No Phase Reversal When Input Is at Rail

Available in 8-Lead SOIC

### APPLICATIONS

CCD

Low Distortion Filters

Mixed Gain Stages

Audio Amplifier

Photo Detector Interface

ADC Input Buffer

DAC Output Buffer

### CONNECTION DIAGRAM

8-Lead Plastic SOIC (R) Package

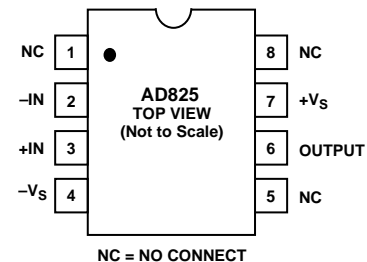

### PRODUCT DESCRIPTION

The AD825 is a superbly optimized operational amplifier for high speed, low cost and dc parameters, making it ideally suited for a broad range of signal conditioning and data acquisition applications. The ac performance, gain, bandwidth, slew rate and drive capability are all very stable over temperature. The AD825 also maintains stable gain under varying load conditions.

The unique input stage has ultralow input bias current and ultralow input current noise. Signals that go to either rail on this high performance input do not cause phase reversals at the output. These features make the AD825 a good choice as a buffer for MUX outputs, creating minimal offset and gain errors.

The AD825 is fully specified for operation with dual  $\pm 5$  V and  $\pm 15$  V supplies. This power supply flexibility, and the low supply current of 6.5 mA with excellent ac characteristics under all supply conditions, makes the AD825 well suited for many demanding applications.

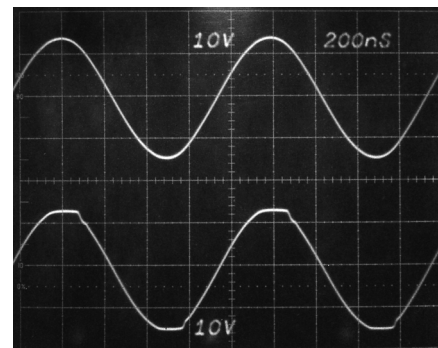

Figure 1. Performance with Rail-to-Rail Input Signals

### REV. C

Information furnished by Analog Devices is believed to be accurate and reliable. However, no responsibility is assumed by Analog Devices for its use, nor for any infringements of patents or other rights of third parties which may result from its use. No license is granted by implication or otherwise under any patent or patent rights of Analog Devices.

# AD825—SPECIFICATIONS (@ $T_A = +25^\circ\text{C}$ , $V_S = \pm 15\text{ V}$ unless otherwise noted)

Parameter	Conditions	$V_S$	AD825A			Units
			Min	Typ	Max	
<b>DYNAMIC PERFORMANCE</b>						
Unity Gain Bandwidth		$\pm 15\text{ V}$	23	26		MHz
Bandwidth for 0.1 dB Flatness	Gain = +1	$\pm 15\text{ V}$	18	21		MHz
-3 dB Bandwidth	Gain = +1	$\pm 15\text{ V}$	44	46		MHz
Slew Rate	$R_{\text{LOAD}} = 1\text{ k}\Omega$ , $G = 1$	$\pm 15\text{ V}$	125	140		V/ $\mu\text{s}$
Settling Time to 0.1%	0 V-10 V Step, $A_V = -1$	$\pm 15\text{ V}$		150	180	ns
to 0.01%	0 V-10 V Step, $A_V = -1$	$\pm 15\text{ V}$		180	220	ns
Total Harmonic Distortion	$F_C = 1\text{ MHz}$ , $G = -1$	$\pm 15\text{ V}$		-77		dB
Differential Gain Error	NTSC	$\pm 15\text{ V}$		1.3		%
( $R_{\text{LOAD}} = 150\ \Omega$ )	Gain = +2					
Differential Phase Error	NTSC	$\pm 15\text{ V}$		2.1		Degrees
( $R_{\text{LOAD}} = 150\ \Omega$ )	Gain = +2					
<b>INPUT OFFSET VOLTAGE</b>						
Offset Drift	$T_{\text{MIN}}$ to $T_{\text{MAX}}$	$\pm 15\text{ V}$		1	2	mV
					5	mV
				10		$\mu\text{V}/^\circ\text{C}$
<b>INPUT BIAS CURRENT</b>						
	$T_{\text{MIN}}$	$\pm 15\text{ V}$	5	15	40	pA
	$T_{\text{MAX}}$				700	pA
<b>INPUT OFFSET CURRENT</b>						
	$T_{\text{MIN}}$	$\pm 15\text{ V}$	5	20	30	pA
	$T_{\text{MAX}}$				440	pA
<b>OPEN LOOP GAIN</b>						
	$V_{\text{OUT}} = \pm 10\text{ V}$ $R_{\text{LOAD}} = 1\text{ k}\Omega$	$\pm 15\text{ V}$	70	76		dB
	$V_{\text{OUT}} = \pm 7.5\text{ V}$ $R_{\text{LOAD}} = 1\text{ k}\Omega$	$\pm 15\text{ V}$	70	76		dB
	$V_{\text{OUT}} = \pm 7.5\text{ V}$ $R_{\text{LOAD}} = 150\ \Omega$ (50 mA Output)	$\pm 15\text{ V}$	72	74		dB
<b>COMMON-MODE REJECTION</b>						
	$V_{\text{CM}} = \pm 10\text{ V}$	$\pm 15\text{ V}$	71	80		dB
<b>INPUT VOLTAGE NOISE</b>						
	$f = 10\text{ kHz}$	$\pm 15\text{ V}$		12		$\text{nV}/\sqrt{\text{Hz}}$
<b>INPUT CURRENT NOISE</b>						
	$f = 10\text{ kHz}$	$\pm 15\text{ V}$		10		$\text{fA}/\sqrt{\text{Hz}}$
<b>INPUT COMMON-MODE VOLTAGE RANGE</b>						
		$\pm 15\text{ V}$		$\pm 13.5$		V
<b>OUTPUT VOLTAGE SWING</b>						
	$R_{\text{LOAD}} = 1\text{ k}\Omega$	$\pm 15\text{ V}$	13	$\pm 13.3$		V
	$R_{\text{LOAD}} = 500\ \Omega$	$\pm 15\text{ V}$	12.9	$\pm 13.2$		V
Output Current		$\pm 15\text{ V}$	50			mA
Short-Circuit Current		$\pm 15\text{ V}$		100		mA
<b>INPUT RESISTANCE</b>						
				$5 \times 10^{11}$		$\Omega$
<b>INPUT CAPACITANCE</b>						
				6		pF
<b>OUTPUT RESISTANCE</b>						
	Open Loop			8		$\Omega$
<b>POWER SUPPLY</b>						
Quiescent Current	$T_{\text{MIN}}$ to $T_{\text{MAX}}$	$\pm 15\text{ V}$		6.5	7.2	mA
		$\pm 15\text{ V}$			7.5	mA

## NOTES

All limits are determined to be at least four standard deviations away from mean value.

Specifications subject to change without notice.

# SPECIFICATIONS (@ $T_A = +25^\circ\text{C}$ , $V_S = \pm 5\text{ V}$ unless otherwise noted)

# AD825

Parameter	Conditions	$V_S$	AD825A			Units
			Min	Typ	Max	
<b>DYNAMIC PERFORMANCE</b>						
Unity Gain Bandwidth		$\pm 5\text{ V}$	18	21		MHz
Bandwidth for 0.1 dB Flatness	Gain = +1	$\pm 5\text{ V}$	8	10		MHz
-3 dB Bandwidth	Gain = +1	$\pm 5\text{ V}$	34	37		MHz
Slew Rate	$R_{LOAD} = 1\text{ k}\Omega$ , $G = -1$	$\pm 5\text{ V}$	115	130		V/ $\mu\text{s}$
Settling Time to 0.1%	-2.5 V to +2.5 V	$\pm 5\text{ V}$		75	90	ns
to 0.01%	-2.5 V to +2.5 V	$\pm 5\text{ V}$		90	110	ns
Total Harmonic Distortion	$F_C = 1\text{ MHz}$ , $G = -1$	$\pm 5\text{ V}$		-76		dB
Differential Gain Error ( $R_{LOAD} = 150\ \Omega$ )	NTSC Gain = +2	$\pm 5\text{ V}$		1.2		%
Differential Phase Error ( $R_{LOAD} = 150\ \Omega$ )	NTSC Gain = +2	$\pm 5\text{ V}$		1.4		Degrees
<b>INPUT OFFSET VOLTAGE</b>						
Offset Drift	$T_{MIN}$ to $T_{MAX}$	$\pm 5\text{ V}$		1 10	2 5	mV mV $\mu\text{V}/^\circ\text{C}$
<b>INPUT BIAS CURRENT</b>						
	$T_{MIN}$ $T_{MAX}$	$\pm 5\text{ V}$	5	10	30	pA pA pA
<b>INPUT OFFSET CURRENT</b>						
Offset Current Drift	$T_{MIN}$ $T_{MAX}$	$\pm 5\text{ V}$	5	15	25	pA pA pA
<b>OPEN LOOP GAIN</b>						
	$V_{OUT} = \pm 2.5\text{ V}$ $R_{LOAD} = 500\ \Omega$ $R_{LOAD} = 150\ \Omega$	$\pm 5\text{ V}$	64 64	66 66		dB dB
<b>COMMON-MODE REJECTION</b>						
	$V_{CM} = \pm 2\text{ V}$	$\pm 5\text{ V}$	69	80		dB
<b>INPUT VOLTAGE NOISE</b>						
	$f = 10\text{ kHz}$	$\pm 5\text{ V}$		12		$\text{nV}/\sqrt{\text{Hz}}$
<b>INPUT CURRENT NOISE</b>						
	$f = 10\text{ kHz}$	$\pm 5\text{ V}$		10		$\text{fA}/\sqrt{\text{Hz}}$
<b>INPUT COMMON-MODE VOLTAGE RANGE</b>						
		$\pm 5\text{ V}$		$\pm 3.5$		V
<b>OUTPUT VOLTAGE SWING</b>						
Output Current	$R_{LOAD} = 500\ \Omega$	$\pm 5\text{ V}$	3.2	$\pm 3.4$		V
Short-Circuit Current	$R_{LOAD} = 150\ \Omega$	$\pm 5\text{ V}$	3.1	$\pm 3.2$		V
		$\pm 5\text{ V}$	50			mA
		$\pm 5\text{ V}$		80		mA
<b>INPUT RESISTANCE</b>						
				$5 \times 10^{11}$		$\Omega$
<b>INPUT CAPACITANCE</b>						
				6		pF
<b>OUTPUT RESISTANCE</b>						
	Open Loop			8		$\Omega$
<b>POWER SUPPLY</b>						
Quiescent Current	$T_{MIN}$ to $T_{MAX}$	$\pm 5\text{ V}$ $\pm 5\text{ V}$		6.2	6.8	mA
					7.5	mA
<b>POWER SUPPLY REJECTION</b>						
	$V_S = \pm 5\text{ V}$ to $\pm 15\text{ V}$		76	88		dB

## NOTES

All limits are determined to be at least four standard deviations away from mean value.

Specifications subject to change without notice.

# AD825

## ABSOLUTE MAXIMUM RATINGS<sup>1</sup>

Supply Voltage	$\pm 18$ V
Internal Power Dissipation <sup>2</sup>	
Small Outline (R)	See Derating Curves
Input Voltage (Common Mode)	$\pm V_S$
Differential Input Voltage	$\pm V_S$
Output Short Circuit Duration	See Derating Curves
Storage Temperature Range R	$-65^{\circ}\text{C}$ to $+125^{\circ}\text{C}$
Operating Temperature Range	$-40^{\circ}\text{C}$ to $+85^{\circ}\text{C}$
Lead Temperature Range (Soldering 10 sec)	$+300^{\circ}\text{C}$

## NOTES

<sup>1</sup>Stresses above those listed under Absolute Maximum Ratings may cause permanent damage to the device. This is a stress rating only; functional operation of the device at these or any other conditions above those indicated in the operational section of this specification is not implied. Exposure to absolute maximum rating conditions for extended periods may affect device reliability.

<sup>2</sup>Specification is for device in free air: 8-lead SOIC package:  $\theta_{JA} = 155^{\circ}\text{C}/\text{W}$ .

## PIN CONFIGURATION

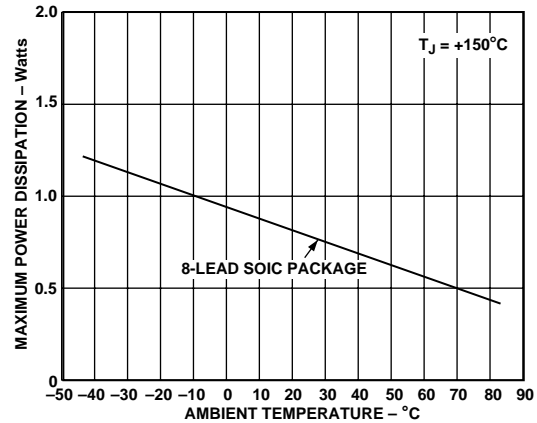
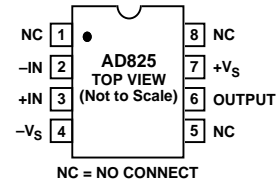

Figure 2. Maximum Power Dissipation vs. Temperature

## ORDERING GUIDE

Model	Temperature Range	Package Description	Package Option
AD825AR	$-40^{\circ}\text{C}$ to $+85^{\circ}\text{C}$	8-Lead Plastic SOIC	SO-8
AD825ACHIPS	$-40^{\circ}\text{C}$ to $+85^{\circ}\text{C}$	Die	
AD825AR-REEL	$-40^{\circ}\text{C}$ to $+85^{\circ}\text{C}$	13" Tape and Reel	SO-8
AD825AR-REEL7	$-40^{\circ}\text{C}$ to $+85^{\circ}\text{C}$	7" Tape and Reel	SO-8

## CAUTION

ESD (electrostatic discharge) sensitive device. Electrostatic charges as high as 4000 V readily accumulate on the human body and test equipment and can discharge without detection. Although the AD825 features proprietary ESD protection circuitry, permanent damage may occur on devices subjected to high energy electrostatic discharges. Therefore, proper ESD precautions are recommended to avoid performance degradation or loss of functionality.



# Typical Characteristics—AD825

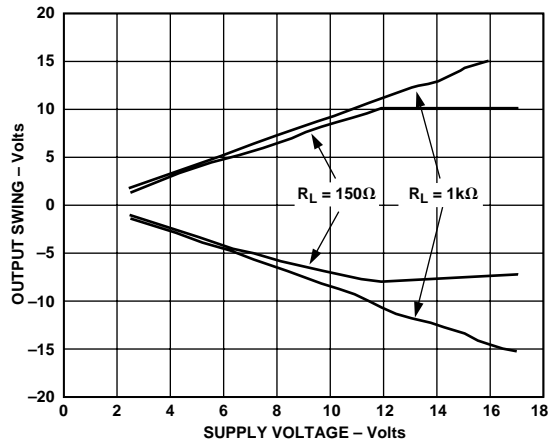

Figure 3. Output Voltage Swing vs. Supply

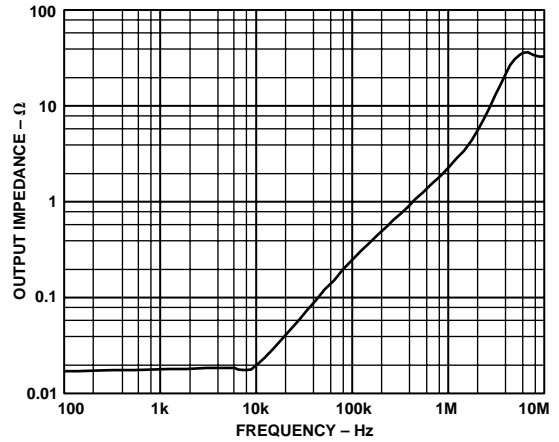

Figure 6. Closed-Loop Output Impedance vs. Frequency

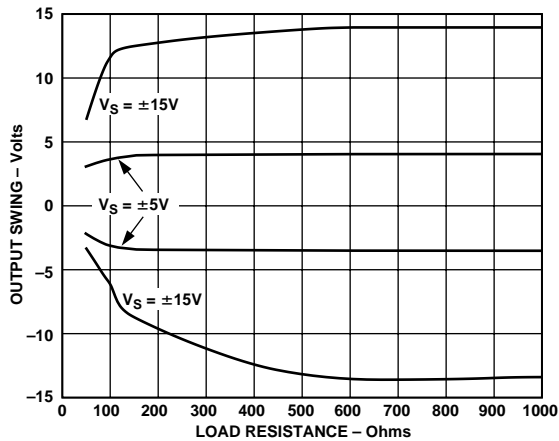

Figure 4. Output Voltage Swing vs. Load Resistance

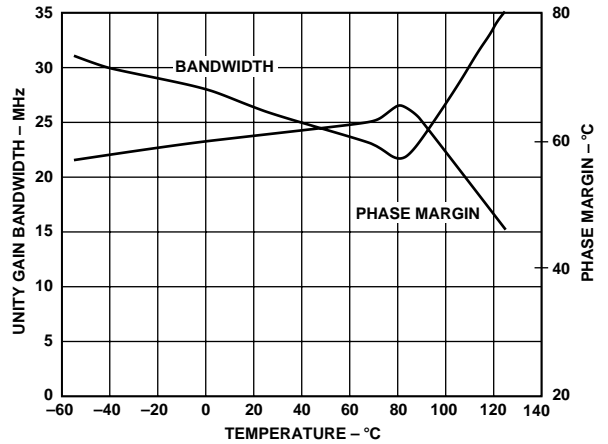

Figure 7. Unity Gain Bandwidth and Phase Margin vs. Temperature

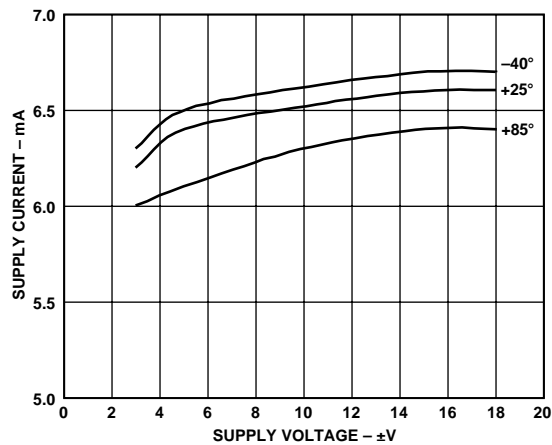

Figure 5. Quiescent Supply Current vs. Supply Voltage for Various Temperatures

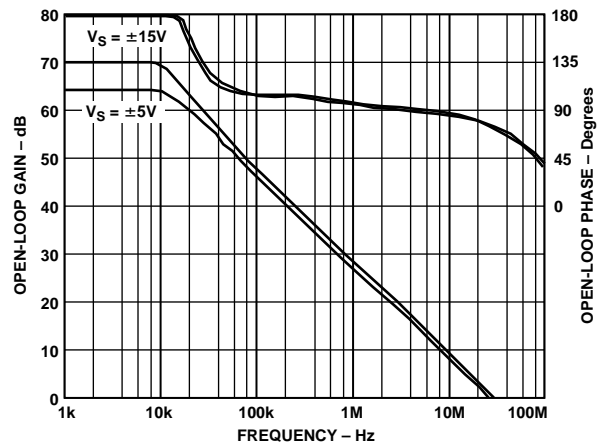

Figure 8. Open-Loop Gain and Phase Margin vs. Frequency

# AD825

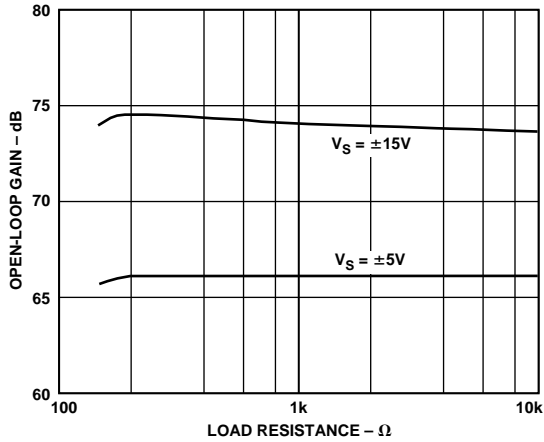

Figure 9. Open-Loop Gain vs. Load Resistance

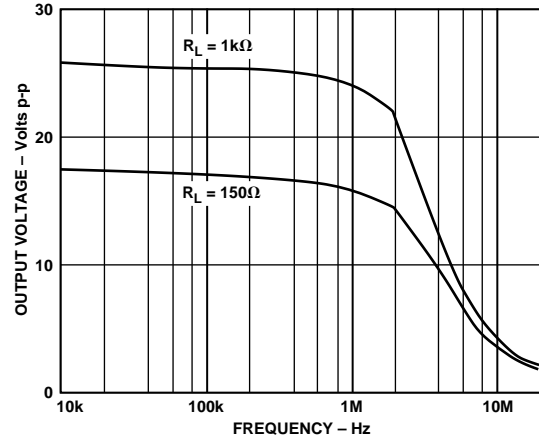

Figure 12. Large Signal Frequency Response;  $G = +2$

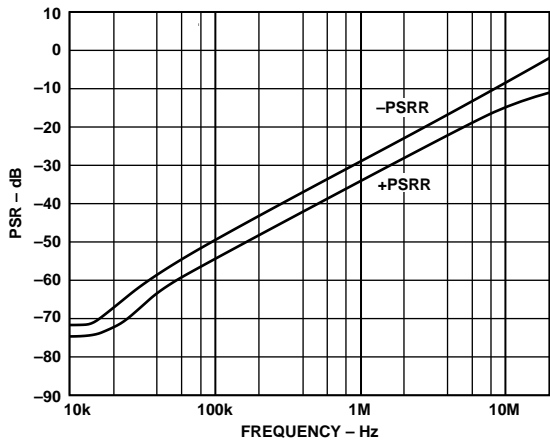

Figure 10. Power Supply Rejection vs. Frequency

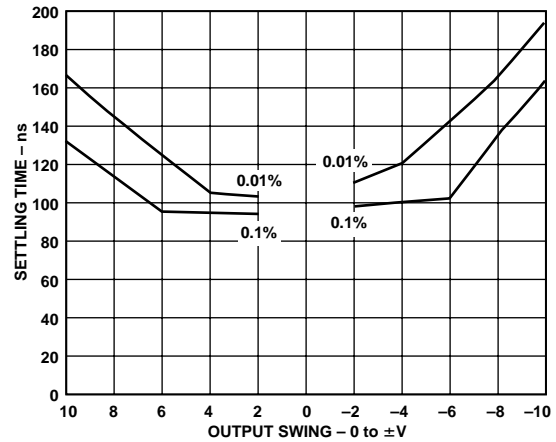

Figure 13. Output Swing and Error vs. Settling Time

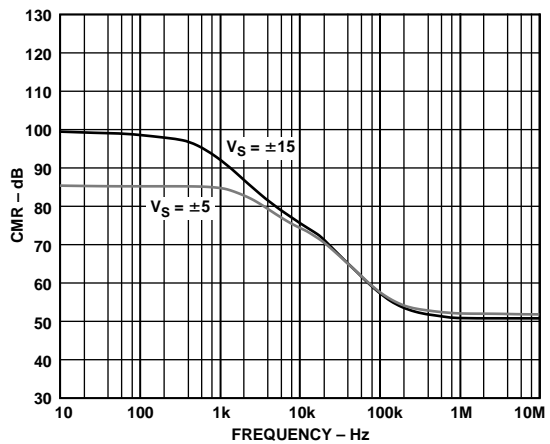

Figure 11. Common-Mode Rejection vs. Frequency

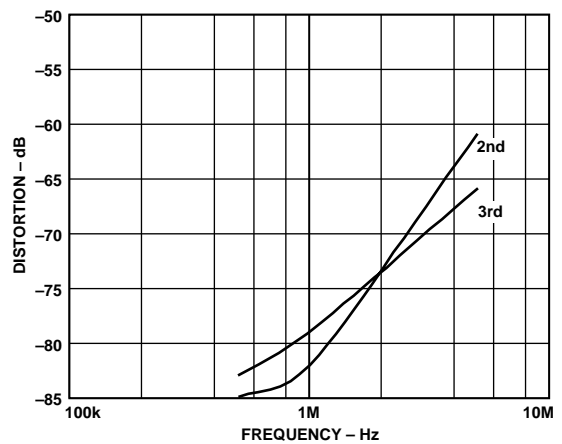

Figure 14. Harmonic Distortion vs. Frequency

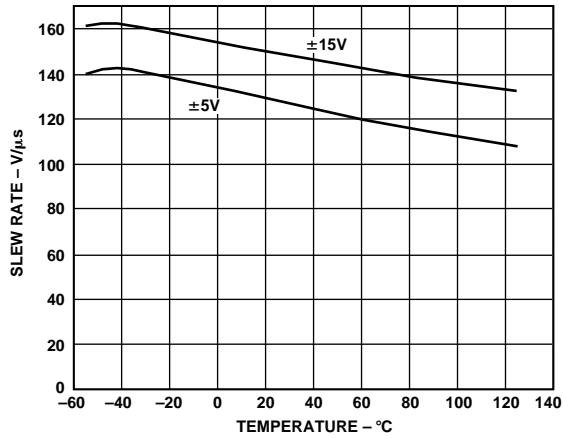

Figure 15. Slew Rate vs. Temperature

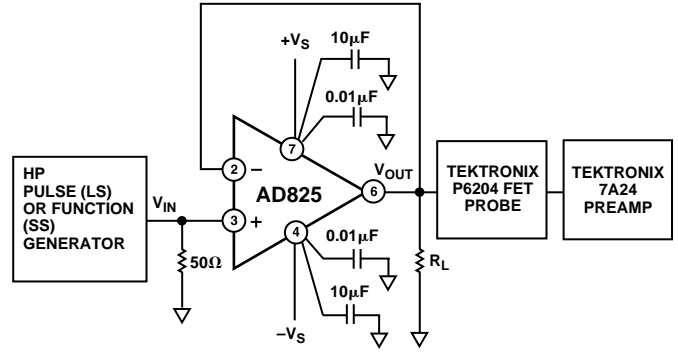

Figure 18. Noninverting Amplifier Connection

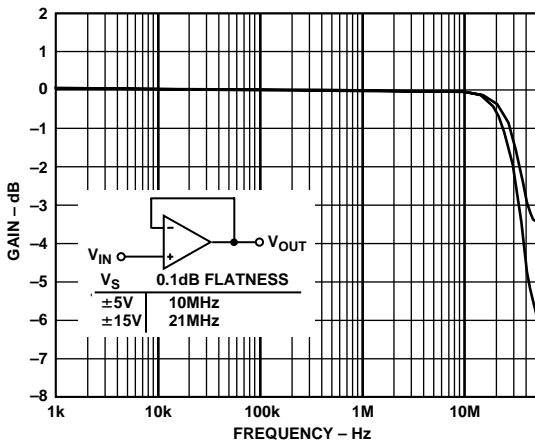

Figure 16. Closed-Loop Gain vs. Frequency, Gain = +1

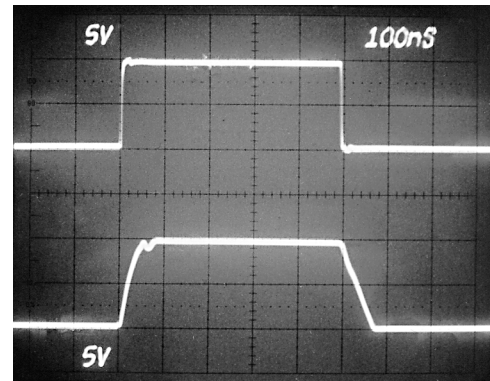

Figure 19. Noninverting Large Signal Pulse Response,  $R_L = 1\text{ k}\Omega$

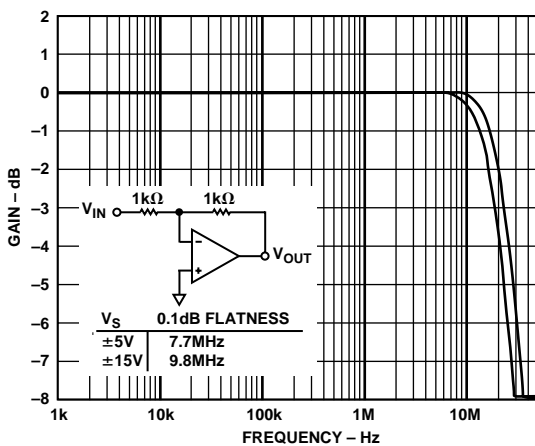

Figure 17. Closed-Loop Gain vs. Frequency, Gain = -1

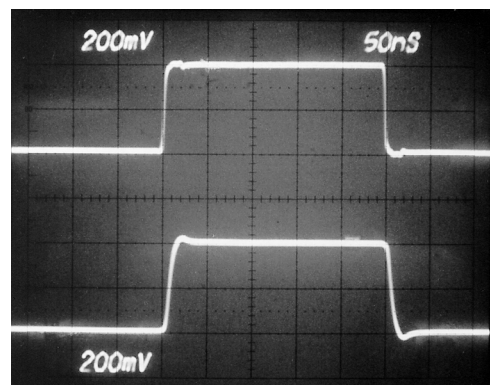

Figure 20. Noninverting Small Signal Pulse Response,  $R_L = 1\text{ k}\Omega$

# AD825

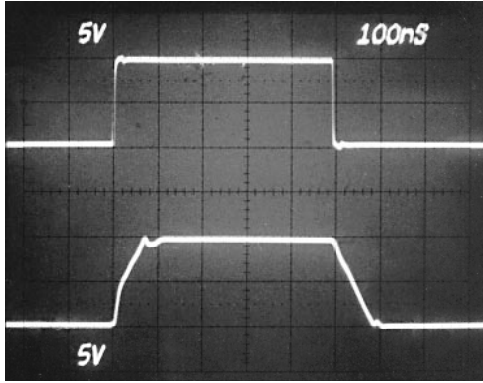

Figure 21. Noninverting Large Signal Pulse Response,  $R_L = 150 \Omega$

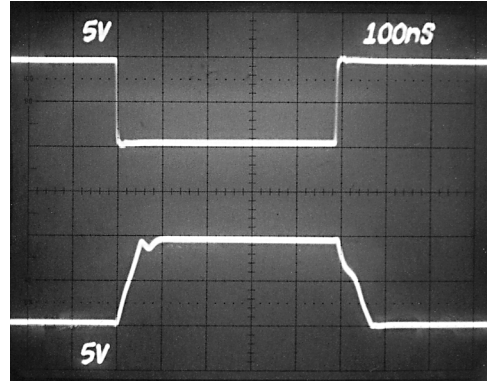

Figure 24. Inverting Large Signal Pulse Response,  $R_L = 1 \text{ k}\Omega$

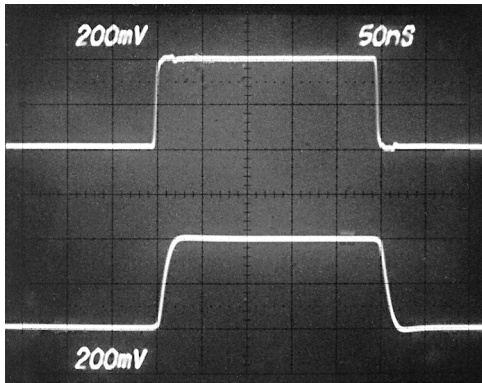

Figure 22. Noninverting Small Signal Pulse Response,  $R_L = 150 \Omega$

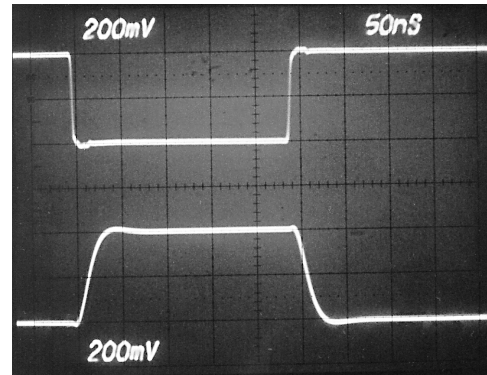

Figure 25. Inverting Small Signal Pulse Response,  $R_L = 1 \text{ k}\Omega$

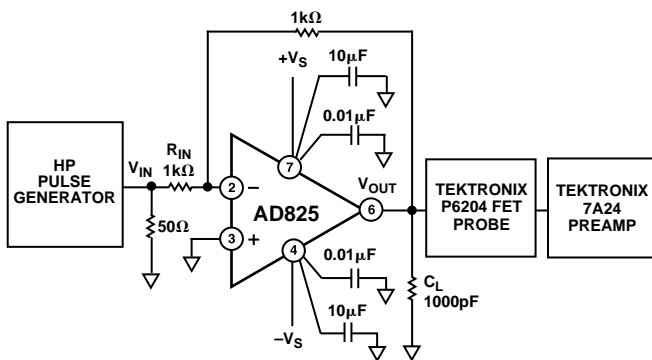

Figure 23. Inverting Amplifier Connection

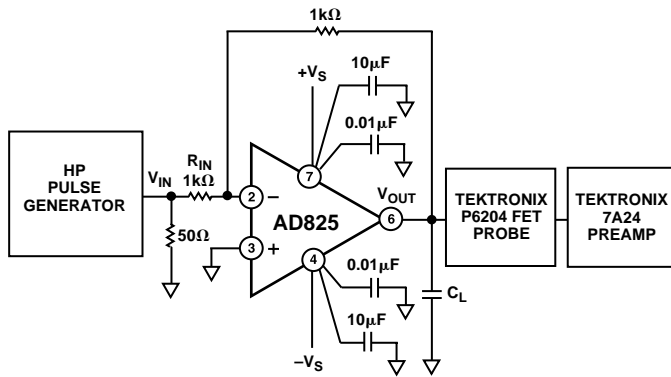

Figure 26a. Inverting Amplifier Driving a Capacitive Load

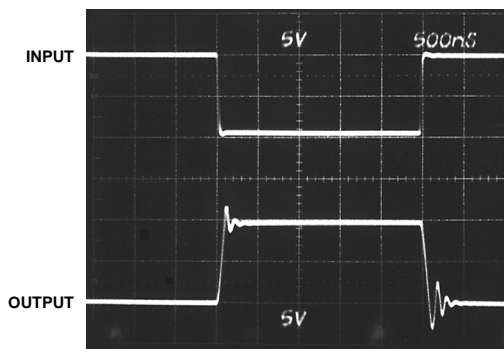

Figure 26b. Inverting Amplifier Pulse Response While Driving a 400 pF Capacitive Loads

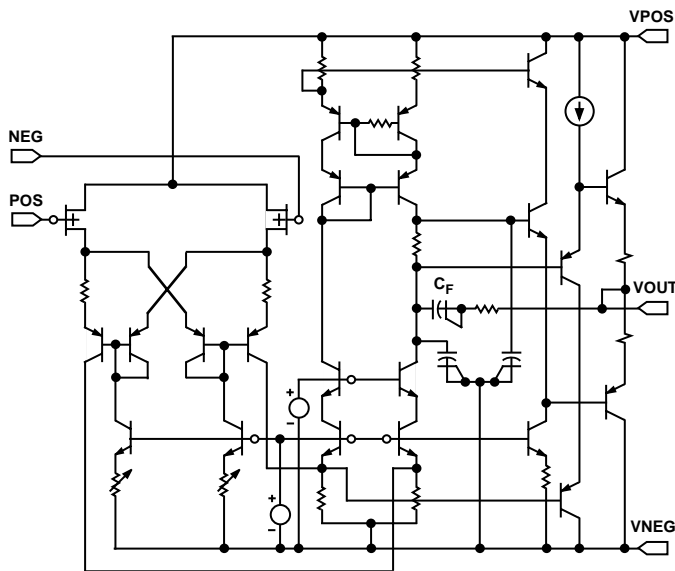

Figure 27. Simplified Schematic

## DRIVING CAPACITIVE LOADS

The internal compensation of the AD825, together with its high output current drive, permits excellent large signal performance while driving extremely high capacitive loads.

## THEORY OF OPERATION

The AD825 is a low cost, wide band, high performance FET input operational amplifier. With its unique input stage design, the AD825 assures no phase reversal even for inputs that exceed the power supply voltages, and its output stage is designed to drive heavy capacitive or resistive load with small changes relative to no load condition.

The AD825 (Figure 27) consists of common-drain common-base FET input stage driving a cascoded, common base matched NPN gain stage. The output buffer stage uses emitter followers in a class AB amplifier that can deliver large current to the load while maintaining low levels of distortion.

The capacitor,  $C_F$  in the output stage, enables the AD825 to drive heavy capacitive load. For light load, the gain of the output buffer is close to unity,  $C_F$  is bootstrapped and not much happens. As the capacitive load is increased, the gain of the output buffer is decreased and the bandwidth of the amplifier is reduced through a portion of  $C_F$  adding to the dominant pole. As the capacitive load is further increased, the amplifier's bandwidth continues to drop, maintaining the stability of the AD825.

## Input Consideration

The AD825 with its unique input stage assures no phase reversal for signals as large or even larger than the supply voltages. Also, layout considerations of the input transistors assure functionality even with a large differential signal.

The need for a low noise input stage calls for a larger FET transistor. One should consider the additional capacitance that is added to assure stability. When filters are designed with the AD825, one needs to consider the input capacitance (5 pF–6 pF) of the AD825 as part of the passive network.

## Grounding and Bypassing

The AD825 is a low input bias current FET amplifier. Its high frequency response makes it useful in applications such as photo diode interfaces, filters and audio circuits. When designing high frequency circuits, some special precautions are in order. Circuits must be built with short interconnects, and resistances should have low inductive paths to ground. Power supply leads should be bypassed to common as close as possible to the amplifier pins. Ceramic capacitors of 0.1  $\mu$ F are recommended.

# AD825

## Second Order Low-Pass Filter

A second order Butterworth low-pass filter can be implemented using the AD825 as shown in Figure 28. The extremely low bias currents of the AD825 allow the use of large resistor values, and consequently small capacitor values, without concern for developing large offset errors. Low current noise is another factor in permitting the use of large resistors without having to worry about the resultant voltage noise.

With the values shown, the corner frequency will be 1 MHz. The equations for component selection are shown below. Note that the noninverting input (and the inverting input) has an input capacitance of 6 pF. As a result, the calculated value of C1 (12 pF) is reduced to 6 pF.

$$C1 = \frac{1.414}{2\pi f_{CUTOFF} R1}$$

$$C2 (\text{farads}) = \frac{0.707}{2\pi f_{CUTOFF} R1}$$

$$R1 = R2 = \text{user selected (typically } 10 \text{ k}\Omega \text{ to } 100 \text{ k}\Omega)$$

A plot of the filter frequency response is shown in Figure 29; better than 40 dB of high frequency rejection is provided.

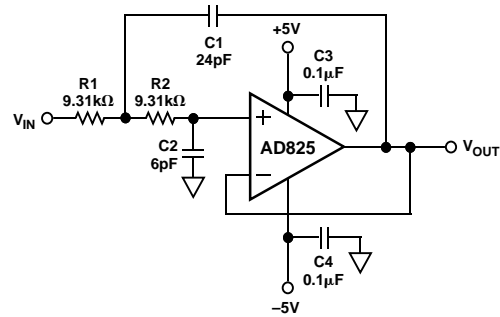

Figure 28. Second Order Butterworth Low-Pass Filter

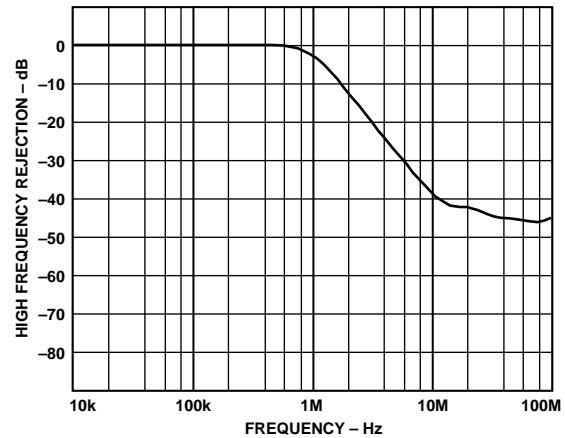
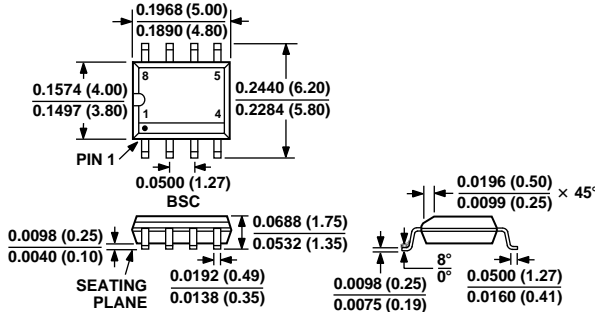

Figure 29. Frequency Response of Second Order Butterworth Filter

OUTLINE DIMENSIONS

Dimensions shown in inches and (mm).

8-Lead Plastic SOIC  
(SO-8)



C3206c-0-12/99

PRINTED IN U.S.A.



LittleDiode supplies new, hard to find or obsolete electronic components and semiconductors all over the world.

With over two million different components listed you are sure to find the part you need.

Feel free to visit us today at our online store:

[LittleDiode.com](http://LittleDiode.com)

Looking forward to providing you with the best possible service.