

## AD8614/AD8644

### FEATURES

**Unity Gain Bandwidth: 5.5 MHz**  
**Low Voltage Offset: 1.0 mV**  
**Slew Rate: 7.5 V/ $\mu$ s**  
**Single-Supply Operation: 5 V to 18 V**  
**High Output Current: 70 mA**  
**Low Supply Current: 800  $\mu$ A/Amplifier**  
**Stable with Large Capacitive Loads**  
**Rail-to-Rail Inputs and Outputs**

### APPLICATIONS

**LCD Gamma and  $V_{COM}$  Drivers**  
**Modems**  
**Portable Instrumentation**  
**Direct Access Arrangement**

### GENERAL DESCRIPTION

The AD8614 (single) and AD8644 (quad) are single-supply, 5.5 MHz bandwidth, rail-to-rail amplifiers optimized for LCD monitor applications.

They are processed using Analog Devices high voltage, high speed, complementary bipolar process—HV XFCB. This proprietary process includes trench isolated transistors that lower internal parasitic capacitance which improves gain bandwidth, phase margin and capacitive load drive. The low supply current of 800  $\mu$ A (typ) per amplifier is critical for portable or densely packed designs. In addition, the rail-to-rail output swing provides greater dynamic range and control than standard video amplifiers provide.

These products operate from supplies of 5 V to as high as 18 V. The unique combination of an output drive of 70 mA, high slew rates, and high capacitive drive capability makes the AD8614/AD8644 an ideal choice for LCD applications.

The AD8614 and AD8644 are specified over the temperature range of  $-20^{\circ}\text{C}$  to  $+85^{\circ}\text{C}$ . They are available in 5-lead SOT-23, 14-lead TSSOP and 14-lead SOIC surface mount packages in tape and reel.

### PIN CONFIGURATIONS

5-Lead SOT-23  
(RT Suffix)

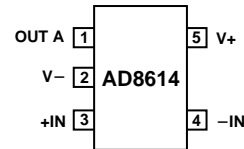

14-Lead TSSOP  
(RU Suffix)

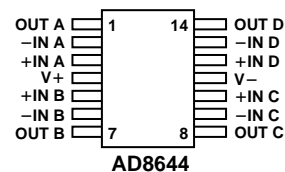

14-Lead Narrow Body SO  
(R Suffix)

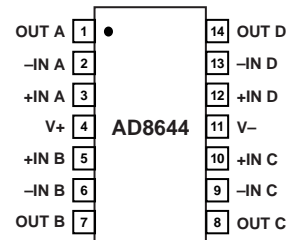

### REV. 0

Information furnished by Analog Devices is believed to be accurate and reliable. However, no responsibility is assumed by Analog Devices for its use, nor for any infringements of patents or other rights of third parties which may result from its use. No license is granted by implication or otherwise under any patent or patent rights of Analog Devices.

# AD8614/AD8644—SPECIFICATIONS

## ELECTRICAL CHARACTERISTICS (5 V ≤ V<sub>S</sub> ≤ 18 V, V<sub>CM</sub> = V<sub>S</sub>/2, T<sub>A</sub> = 25°C unless otherwise noted)

Parameter	Symbol	Conditions	Min	Typ	Max	Unit
<b>INPUT CHARACTERISTICS</b>						
Offset Voltage	V <sub>OS</sub>	-20°C ≤ T <sub>A</sub> ≤ +85°C		1.0	2.5	mV
Input Bias Current	I <sub>B</sub>	-20°C ≤ T <sub>A</sub> ≤ +85°C		80	400	nA
Input Offset Current	I <sub>OS</sub>	-20°C ≤ T <sub>A</sub> ≤ +85°C		5	100	nA
Input Voltage Range		-20°C ≤ T <sub>A</sub> ≤ +85°C	0		V <sub>S</sub>	V
Common-Mode Rejection Ratio	CMRR	V <sub>CM</sub> = 0 V to V <sub>S</sub>	60	75		dB
Voltage Gain	A <sub>VO</sub>	V <sub>OUT</sub> = 0.5 V to V <sub>S</sub> - 0.5 V, R <sub>L</sub> = 10 kΩ	10	150		V/mV
<b>OUTPUT CHARACTERISTICS</b>						
Output Voltage High	V <sub>OH</sub>	I <sub>LOAD</sub> = 10 mA	V <sub>S</sub> - 0.15			V
Output Voltage Low	V <sub>OL</sub>	I <sub>LOAD</sub> = 10 mA		65	150	mV
Output Short Circuit Current	I <sub>SC</sub>	-20°C ≤ T <sub>A</sub> ≤ +85°C	35	70		mA
			30			mA
<b>POWER SUPPLY</b>						
PSRR	PSRR	V <sub>S</sub> = ±2.25 V to ±9.25 V	80	110		dB
Supply Current / Amplifier	I <sub>sy</sub>	-20°C ≤ T <sub>A</sub> ≤ +85°C		0.8	1.1	mA
					1.5	mA
<b>DYNAMIC PERFORMANCE</b>						
Slew Rate	SR	C <sub>L</sub> = 200 pF		7.5		V/μs
Gain Bandwidth Product	GBP			5.5		MHz
Phase Margin	Φ <sub>o</sub>			65		Degrees
Settling Time	t <sub>s</sub>	0.01%, 10 V Step		3		μs
<b>NOISE PERFORMANCE</b>						
Voltage Noise Density	e <sub>n</sub>	f = 1 kHz		12		nV/√Hz
	e <sub>n</sub>	f = 10 kHz		11		nV/√Hz
Current Noise Density	i <sub>n</sub>	f = 10 kHz		1		pA/√Hz

### NOTE

All typical values are for V<sub>S</sub> = 18 V.

Specifications subject to change without notice.

### ABSOLUTE MAXIMUM RATINGS<sup>1</sup>

Supply Voltage	20 V
Input Voltage	GND to V <sub>S</sub>
Storage Temperature Range	-65°C to +150°C
Operating Temperature Range	-20°C to +85°C
Junction Temperature Range	-65°C to +150°C
Lead Temperature Range (Soldering, 60 sec)	300°C

### NOTES

<sup>1</sup>Stresses above those listed under Absolute Maximum Ratings may cause permanent damage to the device. This is a stress rating only; functional operation of the device at these or any other conditions above those listed in the operational sections of this specification is not implied. Exposure to absolute maximum rating conditions for extended periods may affect device reliability.

Package Type	θ <sub>JA</sub> <sup>1</sup>	θ <sub>JC</sub>	Unit
5-Lead SOT-23 (RT)	230	140	°C/W
14-Lead TSSOP (RU)	180	35	°C/W
14-Lead SOIC (R)	120	56	°C/W

### NOTE

<sup>1</sup>θ<sub>JA</sub> is specified for worst-case conditions, i.e., θ<sub>JA</sub> is specified for device soldered onto a circuit board for surface mount packages.

### ORDERING GUIDE

Model	Temperature Range	Package Description	Package Option
AD8614ART <sup>1</sup>	-20°C to +85°C	5-Lead SOT-23	RT-5
AD8644ARU <sup>2</sup>	-20°C to +85°C	14-Lead TSSOP	RU-14
AD8644AR <sup>2</sup>	-20°C to +85°C	14-Lead SOIC	R-14

### NOTES

<sup>1</sup>Available in 3,000 or 10,000 piece reels.

<sup>2</sup>Available in 2,500 piece reels only.

### CAUTION

ESD (electrostatic discharge) sensitive device. Electrostatic charges as high as 4000 V readily accumulate on the human body and test equipment and can discharge without detection. Although the AD8614/AD8644 features proprietary ESD protection circuitry, permanent damage may occur on devices subjected to high energy electrostatic discharges. Therefore, proper ESD precautions are recommended to avoid performance degradation or loss of functionality.



# Typical Performance Characteristics – AD8614/AD8644

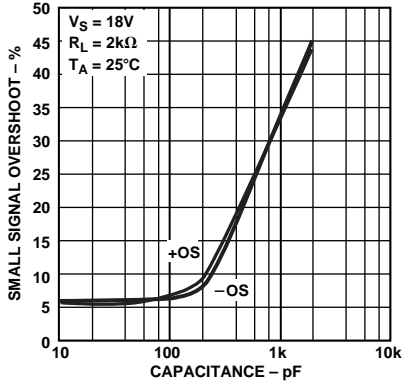

Figure 1. Small Signal Overshoot vs. Load Capacitance

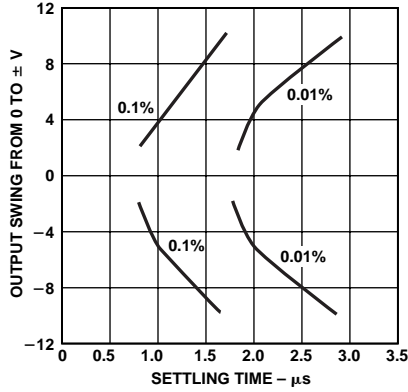

Figure 2. Settling Time

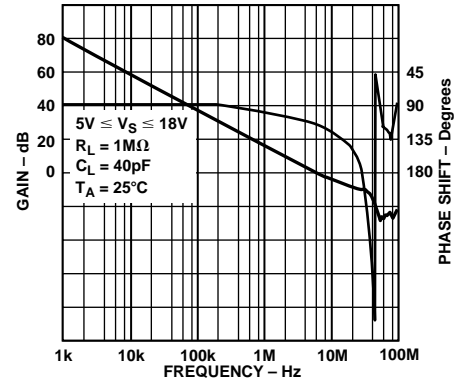

Figure 3. Open-Loop Gain and Phase vs. Frequency

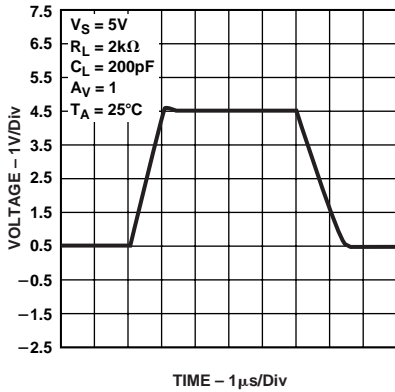

Figure 4. Large Signal Transient Response

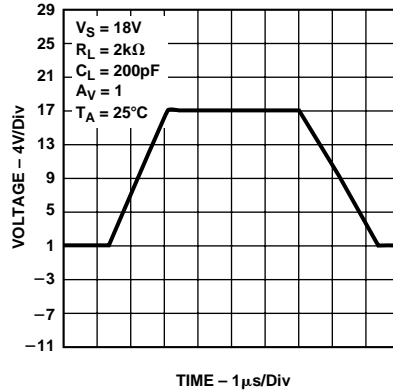

Figure 5. Large Signal Transient Response

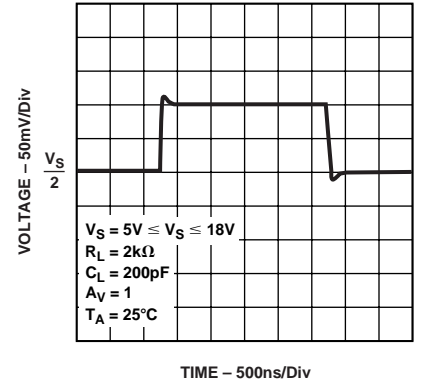

Figure 6. Small Signal Transient Response

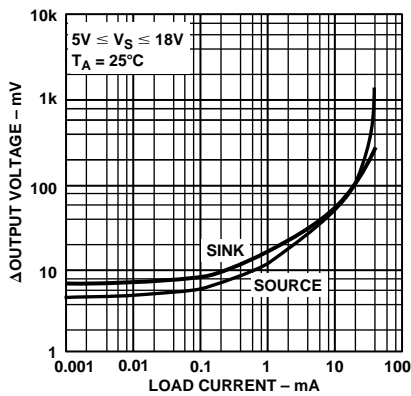

Figure 7. Output Voltage to Supply Rail vs. Load Current



Figure 8. Supply Current vs. Supply Voltage

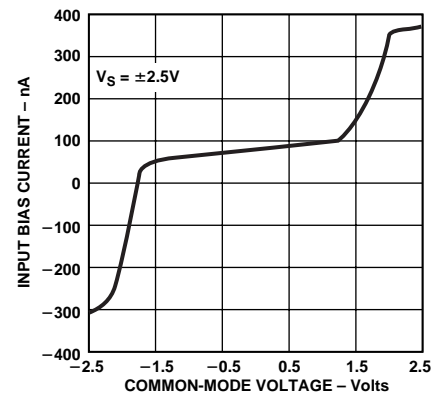

Figure 9. Input Bias Current vs. Common-Mode Voltage

# AD8614/AD8644

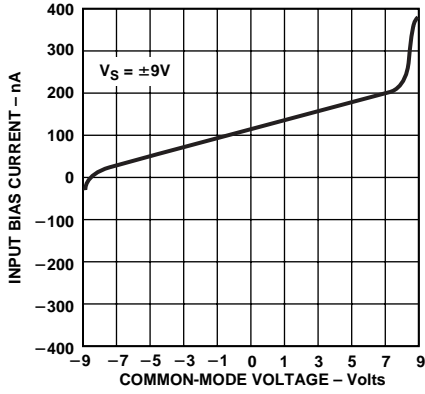

Figure 10. Input Bias Current vs. Common-Mode Voltage

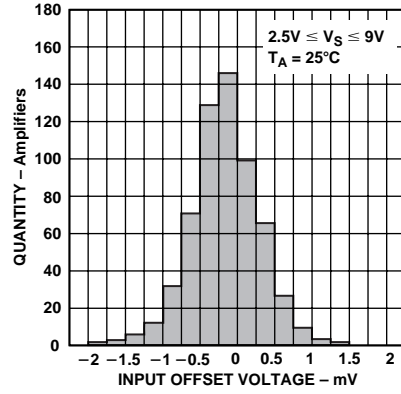

Figure 11. Input Offset Voltage Distribution

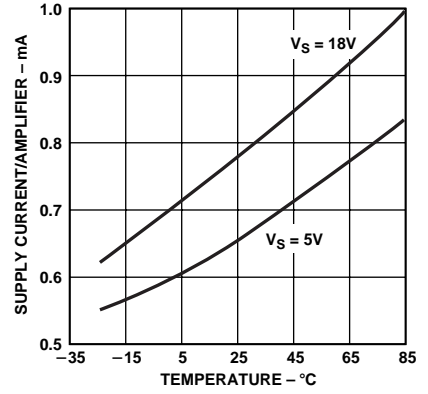

Figure 12. Supply Current vs. Temperature

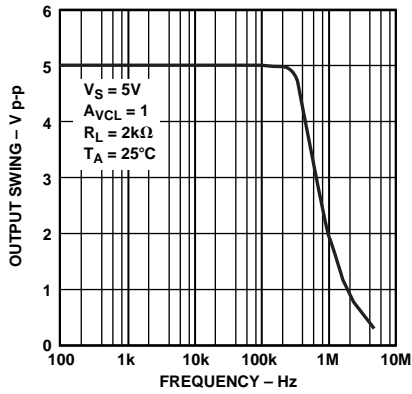

Figure 13. Maximum Output Swing vs. Frequency

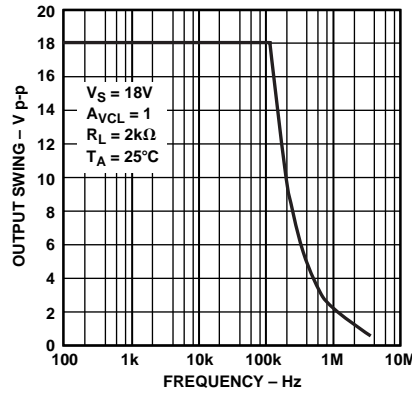

Figure 14. Maximum Output Swing vs. Frequency

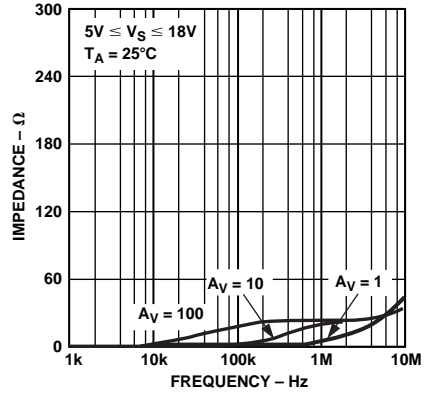

Figure 15. Closed-Loop Output Impedance vs. Frequency

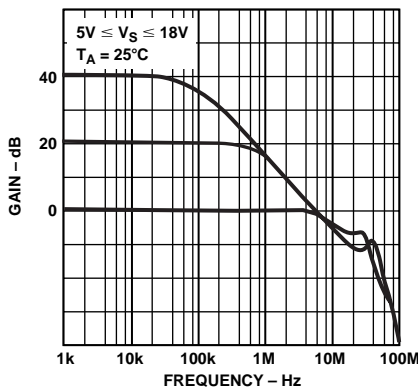

Figure 16. Closed-Loop Gain vs. Frequency

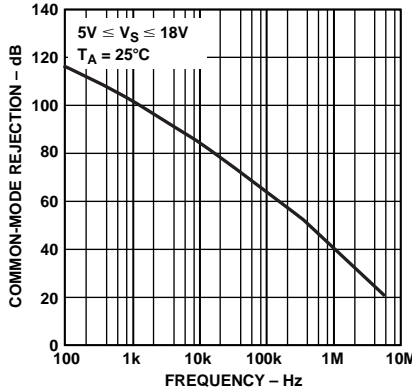

Figure 17. Common-Mode Rejection vs. Frequency

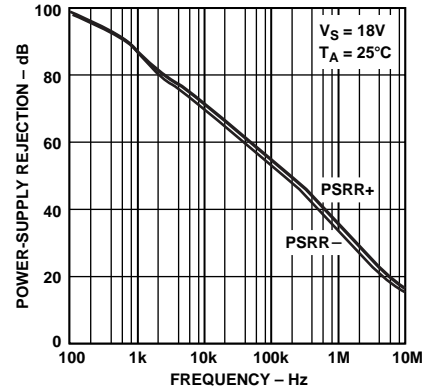

Figure 18. Power-Supply Rejection vs. Frequency

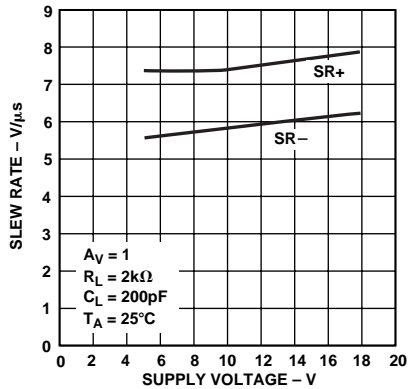

Figure 19. Slew Rate vs. Supply Voltage

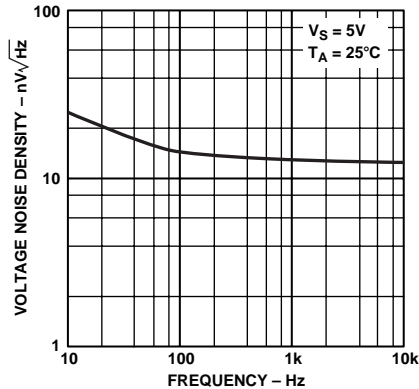

Figure 20. Voltage Noise Density vs. Frequency

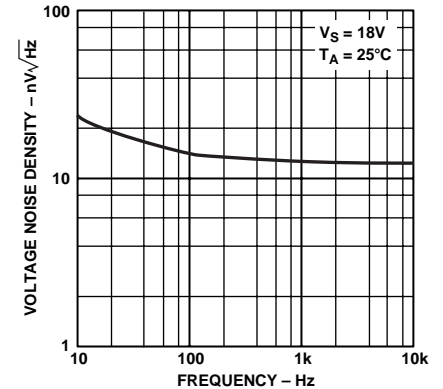

Figure 21. Voltage Noise Density vs. Frequency

## APPLICATIONS SECTION

### Theory of Operation

The AD8614/AD8644 are processed using Analog Devices' high voltage, high speed, complementary bipolar process—HV XFCB. This process includes trench isolated transistors that lower parasitic capacitance.

Figure 22 shows a simplified schematic of the AD8614/AD8644. The input stage is rail-to-rail, consisting of two complementary differential pairs, one NPN pair and one PNP pair. The input stage is protected against avalanche breakdown by two back-to-back diodes. Each input has a 1.5 k $\Omega$  resistor that limits input current during over-voltage events and furnishes phase reversal protection if the inputs are exceeded. The two differential pairs are connected to a double-folded cascode. This is the stage in the amplifier with the most gain. The double folded cascode differentially feeds the output stage circuitry. Two complementary common emitter transistors are used as the output stage. This allows the output to swing to within 125 mV from each rail with a 10 mA load. The gain of the output stage, and thus the open loop gain of the op amp, depends on the load resistance.

The AD8614/AD8644 have no built-in short circuit protection. The short circuit limit is a function of high current roll-off of the output stage transistors and the voltage drop over the resistor shown on the schematic at the output stage. The voltage over this resistor is clamped to one diode during short circuit voltage events.

### Output Short-Circuit Protection

To achieve a wide bandwidth and high slew rate, the output of the AD8614/AD8644 is not short-circuit protected. Shorting the output directly to ground or to a supply rail may destroy the device. The typical maximum safe output current is 70 mA.

In applications where some output current protection is needed, but not at the expense of reduced output voltage headroom, a low value resistor in series with the output can be used. This is shown in Figure 23. The resistor is connected within the feedback loop of the amplifier so that if  $V_{OUT}$  is shorted to ground and  $V_{IN}$  swings up to 18 V, the output current will not exceed 70 mA.

For 18 V single supply applications, resistors less than 261  $\Omega$  are not recommended.

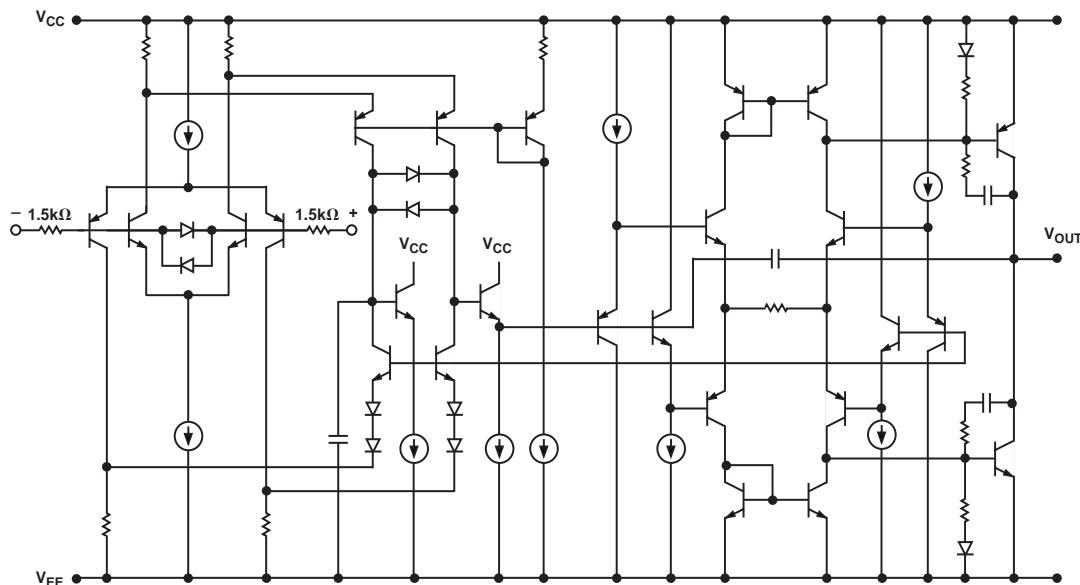

Figure 22. Simplified Schematic

# AD8614/AD8644

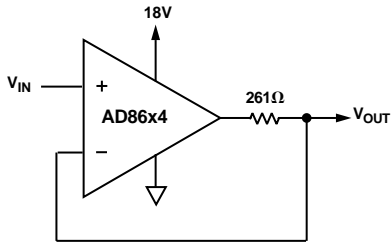

Figure 23. Output Short-Circuit Protection

## Input Overvoltage Protection

As with any semiconductor device, whenever the condition exists for the input to exceed either supply voltage, attention needs to be paid to the input overvoltage characteristic. As an overvoltage occurs, the amplifier could be damaged, depending on the voltage level and the magnitude of the fault current. When the input voltage exceeds either supply by more than 0.6 V, internal pin junctions energize, allowing current to flow from the input to the supplies. Observing Figure 22, the AD8614/AD8644 has 1.5 kΩ resistors in series with each input, which helps limit the current. This input current is not inherently damaging to the device as long as it is limited to 5 mA or less. If the voltage is large enough to cause more than 5 mA of current to flow, an external series resistor should be added. The size of this resistor is calculated by dividing the maximum overvoltage by 5 mA and subtracting the internal 1.5 kΩ resistor. For example, if the input voltage could reach 100 V, the external resistor should be  $(100 \text{ V}/5 \text{ mA}) - 1.5 \text{ k}\Omega = 18.5 \text{ k}\Omega$ . This resistance should be placed in series with either or both inputs if they are subjected to the overvoltages. For more information on general overvoltage characteristics of amplifiers refer to the *1993 System Applications Guide*, available from the Analog Devices Literature Center.

## Output Phase Reversal

The AD8614/AD8644 is immune to phase reversal as long as the input voltage is limited to within the supply rails. Although the device's output will not change phase, large currents due to input overvoltage could result, damaging the device. In applications where the possibility of an input voltage exceeding the supply voltage exists, overvoltage protection should be used, as described in the previous section.

## Power Dissipation

The maximum power that can be safely dissipated by the AD8614/AD8644 is limited by the associated rise in junction temperature. The maximum safe junction temperature is 150°C, and should not be exceeded or device performance could suffer. If this maximum is momentarily exceeded, proper circuit operation will be restored as soon as the die temperature is reduced. Leaving the device in an “overheated” condition for an extended period can result in permanent damage to the device.

To calculate the internal junction temperature of the AD86x4, the following formula can be used:

$$T_j = P_{DISS} \times \theta_{JA} + T_A$$

where:  $T_j$  = AD86x4 junction temperature;

$P_{DISS}$  = AD86x4 power dissipation;

$\theta_{JA}$  = AD86x4 package thermal resistance, junction-to-ambient; and

$T_A$  = Ambient temperature of the circuit.

The power dissipated by the device can be calculated as:

$$P_{DISS} = I_{LOAD} \times (V_S - V_{OUT})$$

where:  $I_{LOAD}$  is the AD86x4 output load current;

$V_S$  is the AD86x4 supply voltage; and

$V_{OUT}$  is the AD86x4 output voltage.

Figure 24 provides a convenient way to see if the device is being overheated. The maximum safe power dissipation can be found graphically, based on the package type and the ambient temperature around the package. By using the previous equation, it is a simple matter to see if  $P_{DISS}$  exceeds the device's power derating curve. To ensure proper operation, it is important to observe the recommended derating curves shown in Figure 24.

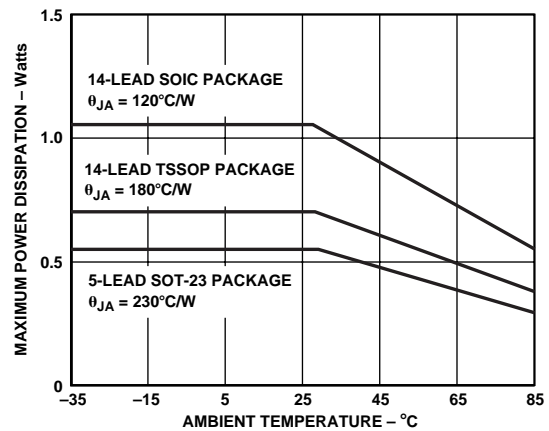

Figure 24. Maximum Power Dissipation vs. Temperature for 5-Lead and 14-Lead Package Types

## Unused Amplifiers

It is recommended that any unused amplifiers in the quad package be configured as a unity gain follower with a 1 kΩ feedback resistor connected from the inverting input to the output, and the noninverting input tied to the ground plane.

## Capacitive Load Drive

The AD8614/AD8644 exhibits excellent capacitive load driving capabilities. Although the device is stable with large capacitive loads, there is a decrease in amplifier bandwidth as the capacitive load increases.

When driving heavy capacitive loads directly from the AD8614/AD8644 output, a snubber network can be used to improve the transient response. This network consists of a series R-C connected from the amplifier's output to ground, placing it in parallel with the capacitive load. The configuration is shown in Figure 25. Although this network will not increase the bandwidth of the amplifier, it will significantly reduce the amount of overshoot.

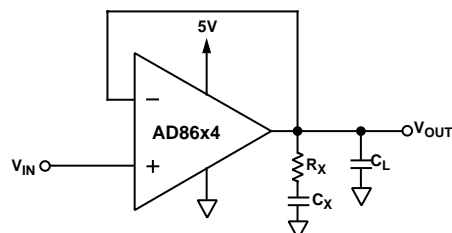

Figure 25. Snubber Network Compensation for Capacitive Loads

The optimum values for the snubber network should be determined empirically based on the size of the capacitive load. Table I shows a few sample snubber network values for a given load capacitance.

**Table I. Snubber Networks for Large Capacitive Loads**

Load Capacitance (C <sub>L</sub> )	Snubber Network (R <sub>s</sub> , C <sub>s</sub> )
0.47 nF	300 Ω, 0.1 μF
4.7 nF	30 Ω, 1 μF
47 nF	5 Ω, 1 μF

**Direct Access Arrangement**

Figure 26 shows a schematic for a 5 V single supply transmit/receive telephone line interface for 600 Ω transmission systems. It allows full duplex transmission of signals on a transformer-coupled 600 Ω line. Amplifier A1 provides gain that can be adjusted to meet the modem output drive requirements. Both A1 and A2 are configured to apply the largest possible differential signal to the transformer. The largest signal available on a single 5 V supply is approximately 4.0 V p-p into a 600 Ω transmission system. Amplifier A3 is configured as a difference amplifier to extract the receive information from the transmission line for amplification by A4. A3 also prevents the transmit signal from interfering with the receive signal. The gain of A4 can be adjusted in the same manner as A1's to meet the modem's input signal requirements. Standard resistor values permit the use of SIP (Single In-Line Package) format resistor arrays. Couple this with the AD8644 14-lead SOIC or TSSOP package and this circuit can offer a compact solution.

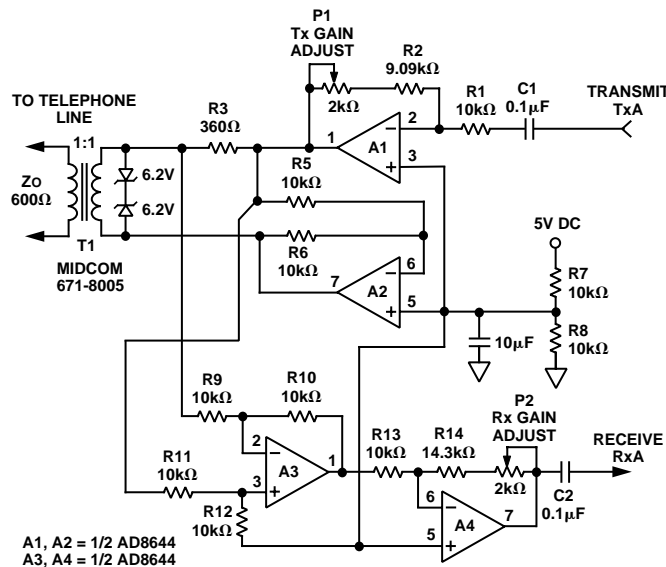

Figure 26. A Single-Supply Direct Access Arrangement for Modems

**A One-Chip Headphone/Microphone Preamplifier Solution**

Because of its high output current performance, the AD8644 makes an excellent amplifier for driving an audio output jack in a computer application. Figure 27 shows how the AD8644 can be interfaced with an ac codec to drive headphones or speakers

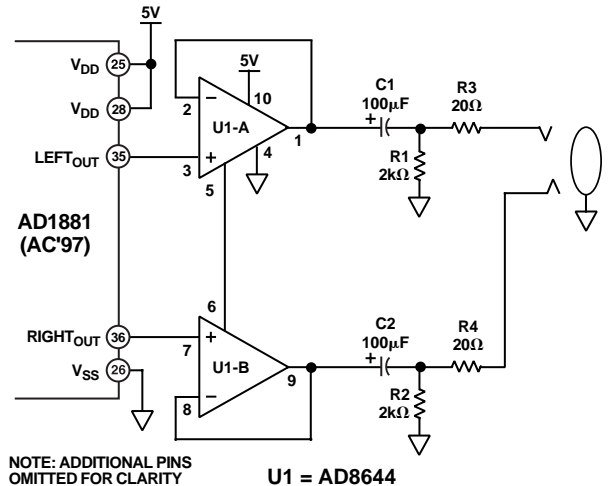

Figure 27. A PC-99 Compliant Headphone/Line Out Amplifier

If gain is required from the output amplifier, four additional resistors should be added as shown in Figure 28. The gain of the AD8644 can be set as:

$$A_V = \frac{R6}{R5}$$

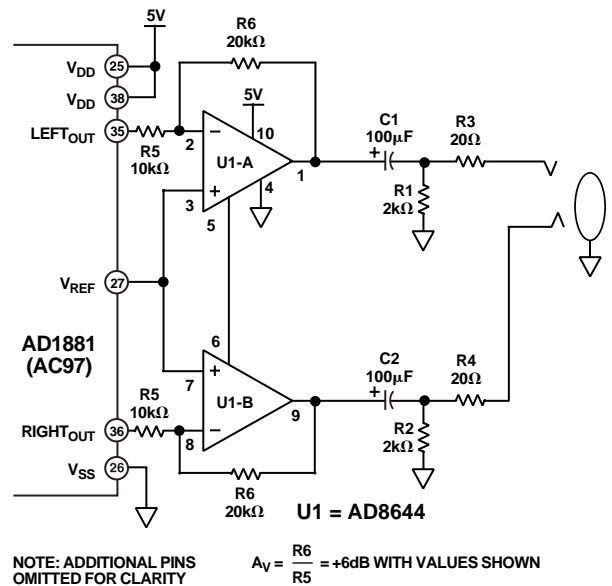

Figure 28. A PC-99-Compliant Headphone/Speaker Amplifier with Gain

Input coupling capacitors are not required for either circuit as the reference voltage is supplied from the AD1881.

R4 and R5 help protect the AD8644 output in case the output jack or headphone wires are accidentally shorted to ground. The output coupling capacitors C1 and C2 block dc current from the headphones and create a high-pass filter with a corner frequency of:

$$f_{-3dB} = \frac{1}{2\pi C1(R4 + R_L)}$$

Where R<sub>L</sub> is the resistance of the headphones.

# AD8614/AD8644

The remaining two amplifiers can be used as low voltage microphone preamplifiers. A single AD8614 can be used as a stand-alone microphone preamplifier. Figure 29 shows this implementation.

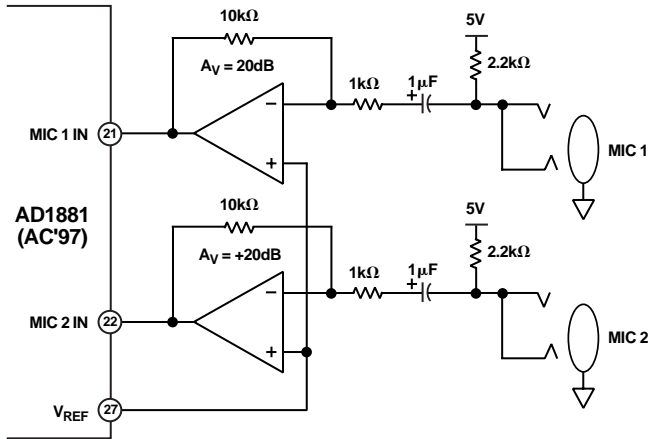

Figure 29. Microphone Preamplifier

## SPICE Model Availability

The SPICE model for the AD8614/AD8644 amplifier is available and can be downloaded from the Analog Devices' web site at <http://www.analog.com>. The macro-model accurately simulates a number of AD8614/AD8644 parameters, including offset voltage, input common-mode range, and rail-to-rail output swing. The output voltage versus output current characteristic of the macro-model is identical to the actual AD8614/AD8644 performance, which is a critical feature with a rail-to-rail amplifier model. The model also accurately simulates many ac effects, such as gain bandwidth product, phase margin, input voltage noise, CMRR and PSRR versus frequency, and transient response. Its high degree of model accuracy makes the AD8614/AD8644 macro-model one of the most reliable and true-to-life models available for any amplifier.

## OUTLINE DIMENSIONS

Dimensions shown in inches and (mm).

### 5-Lead SOT-23 (RT Suffix)

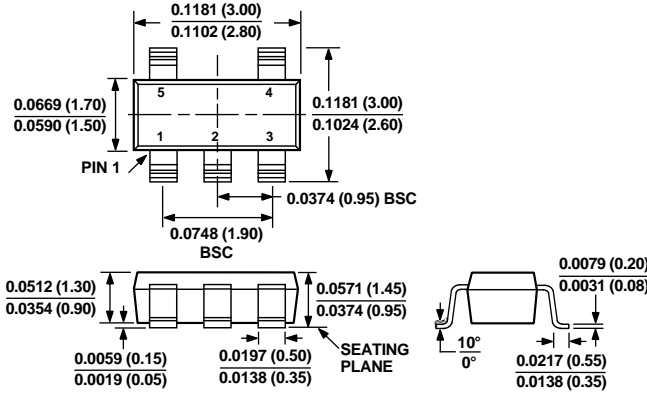

### 14-Lead TSSOP (RU Suffix)

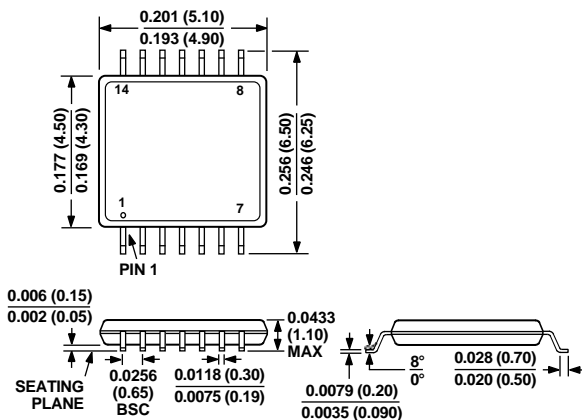

### 14-Lead Narrow SOIC (R Suffix)

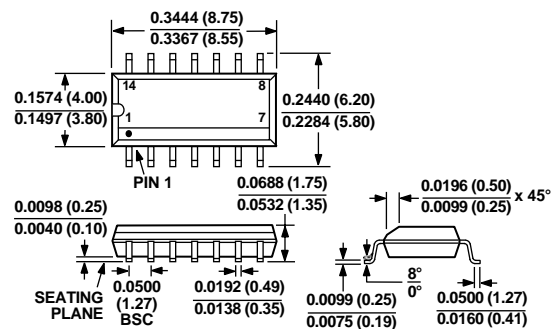



LittleDiode supplies new, hard to find or obsolete electronic components and semiconductors all over the world.

With over two million different components listed you are sure to find the part you need.

Feel free to visit us today at our online store:

[LittleDiode.com](http://LittleDiode.com)

Looking forward to providing you with the best possible service.