

FEATURES

350 MHz Sampling Bandwidth
 125 MHz Sampling Rate
 Excellent Hold Mode Distortion
 -75 dB @ 50 MSPS (25 MHz V_{IN})
 -57 dB @ 125 MSPS (50 MHz V_{IN})
 7 ns Acquisition Time to 0.1%
 <1 ps Aperture Jitter
 66 dB Feedthrough Rejection @ 50 MHz
 3.3 nV/ $\sqrt{\text{Hz}}$ Spectral Noise Density

APPLICATIONS

Direct IF Sampling
 Digital Sampling Oscilloscopes
 HDTV Cameras
 Peak Detectors
 Radar/EW/ECM
 Spectrum Analysis
 Test Equipment/CCD Testers
 DDS DAC Deglitcher

GENERAL DESCRIPTION

The AD9101 is an extremely accurate, general purpose, high speed sampling amplifier. Its fast and accurate acquisition speed allows for a wide range of frequency vs. resolution performance. The AD9101 is capable of 8 to 12 bits of accuracy at clock rates of 125 MSPS or 50 MSPS, respectively. This level of performance makes it an ideal driver for almost all 8- to 12-bit A/D encoders on the market today.

In effect, the AD9101 is a track-and-hold with a post amplifier. This configuration allows the front end sampler to operate at relatively low signal amplitudes. This results in dramatic improvement in both track and hold mode distortion while keeping power low.

The gain-of-four output amplifier has been optimized for fast and accurate large signal step settling characteristics even when heavily loaded. This amplifier's fast Settling Time Linearity (STL) characteristic causes the amplifier to be transparent to the low signal level distortion of the sampler. When sampled, output distortion levels reflect only the distortion performance of the sampler.

Dramatic SNR and distortion improvements can be realized when using the AD9101 with high speed flash converters. Flash converters generally have excellent linearity at dc and low frequencies. However, as signal slew rate increases, their performance degrades due to the internal comparators' aperture delay variations and finite gain bandwidth product.

REV. 0

Information furnished by Analog Devices is believed to be accurate and reliable. However, no responsibility is assumed by Analog Devices for its use, nor for any infringements of patents or other rights of third parties which may result from its use. No license is granted by implication or otherwise under any patent or patent rights of Analog Devices.

FUNCTIONAL BLOCK DIAGRAM

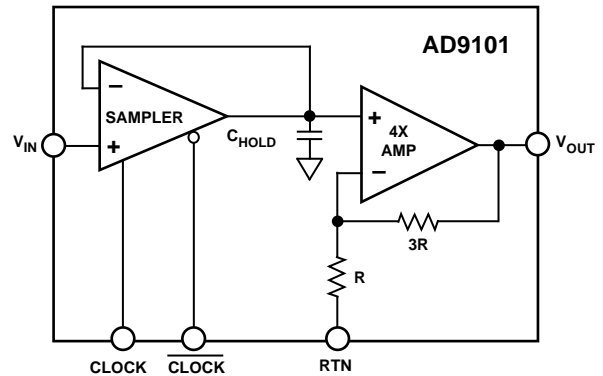

The benefits of using a track-and-hold ahead of a flash converter have been well known for many years. However, before the AD9101, there was no track-and-hold amplifier with sufficient bandwidth and linearity to markedly increase the dynamic performance of such flashes as the AD9002, AD9012, AD9020, and AD9060.

A new application made possible by the AD9101 is direct IF-to-digital conversion. Utilizing the Nyquist principle, the IF frequency can be rejected, and the baseband signal can be recovered. As an example, a 40 MHz IF is modulated by a 10 MHz bandwidth signal. By sampling at 25 MSPS, the signal of interest is detected.

The AD9101 is offered in commercial and military temperature ranges. Commercial versions include the AD9101AR in plastic SOIC and AD9101AE in ceramic LCC. Military devices are available in ceramic LCC. Contact the factory for availability of versions in DIP and/or military versions.

PRODUCT HIGHLIGHTS

1. Guaranteed Hold-Mode Distortion
2. 125 MHz Sampling Rate to 8 Bits; 50 MHz to 12 Bits
3. 350 MHz Sampling Bandwidth
4. Super-Nyquist Sampling Capability
5. Output Offset Adjustable

AD9101–SPECIFICATIONS

ELECTRICAL CHARACTERISTICS ($+V_S = +5\text{ V}$, $-V_S = -5.2\text{ V}$, $R_{LOAD} = 100\ \Omega$, $R_{IN} = 50\ \Omega$ unless otherwise noted)

Parameter	Conditions	Temp	Test Level	AD9101			Units
				Min	Typ	Max	
DC ACCURACY							
Gain	$\Delta V_{IN} = 0.5\text{ V}$	25°C	I	3.93	4	4.07	V/V
Offset	$\Delta V_{IN} = 0.5\text{ V}$	Full	VI	3.9		4.1	V/V
	$V_{IN} = 0\text{ V}$	25°C	I		± 3	± 10	mV
Output Resistance	$V_{IN} = 0\text{ V}$	Full	VI			± 15	mV
		25°C	V		0.4		Ω
Output Drive Capability		Full	VI	± 60	± 70		mA
PSRR	$\Delta V_S = 0.5\text{ V p-p}$	25°C	VI	37	43		dB
Pedestal Sensitivity to Positive Supply	$\Delta V_S = 0.5\text{ V p-p}$	Full	V		4		mV/V
Pedestal Sensitivity to Negative Supply	$\Delta V_S = 0.5\text{ V p-p}$	Full	V		8		mV/V
ANALOG INPUT/OUTPUT							
Output Voltage Range		Full	VI	± 2.4	± 2.7		V
Input Bias Current		25°C	I		± 5	± 15	μA
		Full	VI			± 20	μA
Input Capacitance		25°C	V		2		pF
Input Resistance		25°C– T_{MAX}	VI	30	125		k Ω
		T_{MIN}	VI	25			k Ω
CLOCK/$\overline{\text{CLOCK}}$ INPUTS							
Input Bias Current	$CL/\overline{CL} = -1.0\text{ V}$	Full	VI		3	3.6	mA
Input Low Voltage (V_{IL}) ¹	$V_{IN} = 0.5\text{ V p-p}$	Full	VI	-1.8		-1.5	V
Input High Voltage (V_{IH}) ¹	$V_{IN} = 0.5\text{ V p-p}$	Full	VI	-1.0		-0.8	V
TRACK MODE DYNAMICS							
Bandwidth (-3 dB)	$V_{OUT} = 1\text{ V p-p}$	Full	IV	160	250		MHz
Slew Rate	4 Volt Output Step	Full	IV	1300	1800		V/ μs
Overdrive Recovery Time ² (to 0.1%)	$V_{IN} = \pm 1\text{ V to }0\text{ V}$	25°C	V		55		ns
Integrated Output Noise	(5 MHz–200 MHz)	25°C	V		210		μV
Input RMS Spectral Noise @ 10 MHz		25°C	V		3.3		$\mu\text{V}/\sqrt{\text{Hz}}$
HOLD MODE DYNAMICS							
Worst Harmonic (23 MHz, 50 MSPS)	$V_{OUT} = 2\text{ V p-p}$	25°C	V		-75		dBFS
Worst Harmonic (48 MHz, 100 MSPS)	$V_{OUT} = 2\text{ V p-p}$	25°C	IV		-62	-57	dBFS
Worst Harmonic (48 MHz, 100 MSPS)	$V_{OUT} = 2\text{ V p-p}$	Full (Ind.)	IV			-53	dBFS
Worst Harmonic (48 MHz, 100 MSPS)	$V_{OUT} = 2\text{ V p-p}$	Full (Mil.)	IV			-51	dBFS
Worst Harmonic (48 MHz, 125 MSPS)	$V_{OUT} = 2\text{ V p-p}$	25°C	V		-57		dBFS
Sampling Bandwidth (-3 dB) ³	$V_{IN} = 0.5\text{ V p-p}$	25°C	V		350		MHz
Hold Noise ⁴ (RMS)		Full	V		$150 \times t_H$		mV/s
Droop Rate		25°C	I		± 5	± 18	mV/ μs
		Full	VI			± 40	mV/ μs
Feedthrough Rejection (50 MHz)	$V_{OUT} = 2\text{ V p-p}$	Full	V		-66		dB
TRACK-TO-HOLD SWITCHING							
Aperture Delay		25°C	V		-250		ps
Aperture Jitter		25°C	V		<1		ps rms
Pedestal Offset	$V_{IN} = 0\text{ V}$	25°C	I		± 5	± 20	mV
	$V_{IN} = 0\text{ V}$	Full	VI			± 35	mV
Transient Amplitude	$V_{IN} = 0\text{ V}$	Full	V		8		mV
Settling Time to 4 mV	$V_{IN} = 0\text{ V}$	Full	V		4		ns
Glitch Product ⁵	$V_{IN} = 0\text{ V}$	25°C	V		20		pV-s
HOLD-TO-TRACK SWITCHING							
Acquisition Time to 0.1%	2 V Output Step	25°C	V		7		ns
Acquisition Time to 0.01%	2 V Output Step	25°C	IV		11	14	ns
	2 V Output Step	Full	IV			16	ns
POWER SUPPLY							
+ V_S Current		Full	VI		55	70	mA
- V_S Current		Full	VI		59	73	mA
Power Dissipation		Full	VI		570	715	mW

NOTES

¹If the analog input exceeds ± 300 mV, the clock levels should be shifted as shown in the Theory of Operation section entitled "Driving the Encode Clock."

²Time to recover within rated error band from 160% overdrive.

³Sampling bandwidth is defined as the -3 dB frequency response of the input sampler to the hold capacitor when operating in the sampling mode. It is greater than tracking bandwidth because it does not include the bandwidth of the output amplifier.

⁴Hold mode noise is proportional to the length of time a signal is held. For example, if the hold time (t_H) is 20 ns, the accumulated noise is typically $3 \mu\text{V}$ ($150 \text{ mV/s} \times 20 \text{ ns}$). This value must be combined with the track mode noise to obtain total noise.

⁵Total energy of worst case track-to-hold or hold-to-track glitch.

Specifications subject to change without notice.

ABSOLUTE MAXIMUM RATINGS¹

Supply Voltage ($+V_S$)	-0.5 V to +6 V
Supply Voltage ($-V_S$)	-6 V to +0.5 V
Analog Input Voltage	± 5 V
CLOCK/CLOCK Input	-5 V to +0.5 V
Continuous Output Current ⁴	70 mA
Storage Temperature	-65°C to $+150^\circ\text{C}$
Operating Temperature Range	
AE, AR	-40°C to $+85^\circ\text{C}$
SE	-55°C to $+125^\circ\text{C}$
Junction Temperature (Ceramic) ²	$+175^\circ\text{C}$
Junction Temperature (Plastic) ²	$+150^\circ\text{C}$
Soldering Temperature (1 minute) ³	$+220^\circ\text{C}$

NOTES

¹Absolute maximum ratings are limiting values to be applied individually, and beyond which the serviceability of the circuit may be impaired. Functional operability is not necessarily implied. Exposure to absolute maximum rating conditions for an extended period of time may affect device reliability.

²Typical thermal impedances (no air flow, soldered to PC board) are as follows: Ceramic LCC: $\theta_{JA} = 48^\circ\text{C/W}$; $\theta_{JC} = 9.9^\circ\text{C/W}$; Plastic SOIC: $\theta_{JA} = 54^\circ\text{C/W}$; $\theta_{JC} = 7.3^\circ\text{C/W}$.

³For surface mount devices, mounted by vapor phase soldering. Prior to vapor phase soldering, plastic units should receive a minimum eight hour bakeout at 110°C to drive off any moisture absorbed in plastic during shipping or storage. Through-hole devices can be soldered at $+300^\circ\text{C}$ for 10 seconds.

⁴Output is short circuit protected to ground. Continuous short circuit may affect device reliability.

EXPLANATION OF TEST LEVELS**Test Level**

- I - 100% production tested.
- II - 100% production tested at $+25^\circ\text{C}$, and sample tested at specified temperatures.
- III - Periodically sample tested.
- IV - Parameter is guaranteed by design and characterization testing.
- V - Parameter is a typical value only.
- VI - All devices are 100% production tested at $+25^\circ\text{C}$. 100% production tested at temperature extremes for extended temperature devices; sample tested at temperature extremes for commercial/industrial devices.

ORDERING INFORMATION

Model	Temperature Range	Package Description	Package Option
AD9101AR	-40°C to $+85^\circ\text{C}$	Plastic SOIC	R-20
AD9101AE	-40°C to $+85^\circ\text{C}$	LCC	E-20A
AD9101SE	-55°C to $+125^\circ\text{C}$	LCC	E-20A

CAUTION

ESD (electrostatic discharge) sensitive device. Electrostatic charges as high as 4000 V readily accumulate on the human body and test equipment and can discharge without detection. Although the AD9101 features proprietary ESD protection circuitry, permanent damage may occur on devices subjected to high energy electrostatic discharges. Therefore, proper ESD precautions are recommended to avoid performance degradation or loss of functionality.

Pin Description

Pin	Description	Connection
1	RTN	Gain Set Resistor Return*
2	RTN	Gain Set Resistor Return*
3	C_{B+}	Bootstrap Capacitor (Positive Bias)
4	$+V_S$	+5 V Power Supply (Analog)
5	$+V_S$	+5 V Power Supply (Analog)
6	GND	Hold Capacitor Ground
7	GND	Hold Capacitor Ground
8	$+V_S$	+5 V Power Supply (Digital)
9	$+V_S$	+5 V Power Supply (Digital)
10	CLK	True ECL T/H Clock
11	$\overline{\text{CLK}}$	Complement ECL T/H Clock
12	$-V_S$	-5.2 V Power Supply (Digital)
13	$-V_S$	-5.2 V Power Supply (Digital)
14	N/C	No Connection
15	V_{IN}	Analog Signal Input
16	GND	Ground (Signal Return)
17	$-V_S$	-5.2 V Power Supply (Analog)
18	$-V_S$	-5.2 V Power Supply (Analog)
19	C_{B-}	Bootstrap Capacitor (Negative Bias)
20	V_{OUT}	Analog Signal Output

*See "Matching the AD9101 to A/D Encoders." Both pins should either be grounded or connected to voltage source for offset.

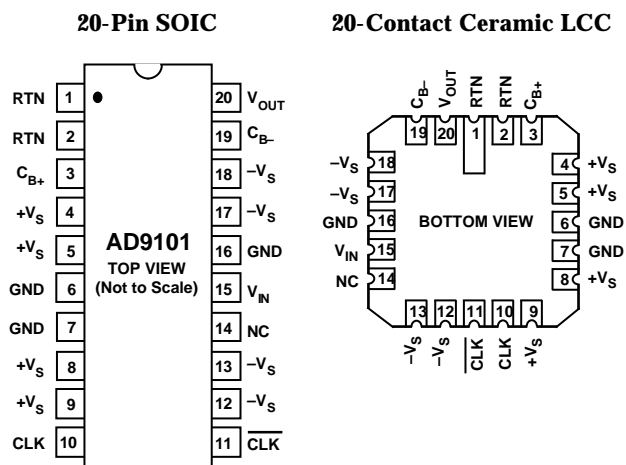
PIN CONFIGURATIONS

AD9101

Acquisition Time is the amount of time it takes the AD9101 to reacquire the analog input when switching from hold to track mode. The interval starts at the 50% clock transition point and ends when the input signal is reacquired to within a specified error band at the hold capacitor.

Aperture Delay establishes when the input signal is actually sampled. It is the time difference between the analog propagation delay of the front-end buffer and the control switch delay time (the time from the hold command transition to when the switch is opened). For the AD9101, this is a negative value, meaning that the analog delay is longer than the switch delay.

Aperture Jitter is the random variation in the aperture delay. This is measured in ps-rms and is manifested as phase noise on the held signal.

Droop Rate is the change in output voltage as a function of time (dV/dt). It is measured at the AD9101 output with the device in hold mode and the input held at a specified dc value; the measurement starts immediately after the T/H switches from track to hold.

Feedthrough Rejection is the ratio of the output signal to the input signal when in hold mode. This is a measure of how well the switch isolates the input signal from feeding through to the output.

Hold-to-Track Switch Delay is the time delay from the track command to the point when the output starts to change to acquire a new signal level.

Pedestal Offset is the offset voltage measured immediately after the AD9101 is switched from track to hold with the input held at zero volts. It manifests itself as a dc offset during the hold time.

Sampling Bandwidth is the -3 dB frequency response from the input to the hold capacitor under sampling conditions. It is greater than the tracking bandwidth because it does not include the bandwidth of the output amplifier which is optimized for settling time rather than bandwidth.

Track-to-Hold Settling Time is the time necessary for the track to hold switching transient to settle to within 4 mV of its final value.

Track-to-Hold Switching Transient is the maximum peak switch induced transient voltage which appears at the AD9101 output when it is switched from track to hold.

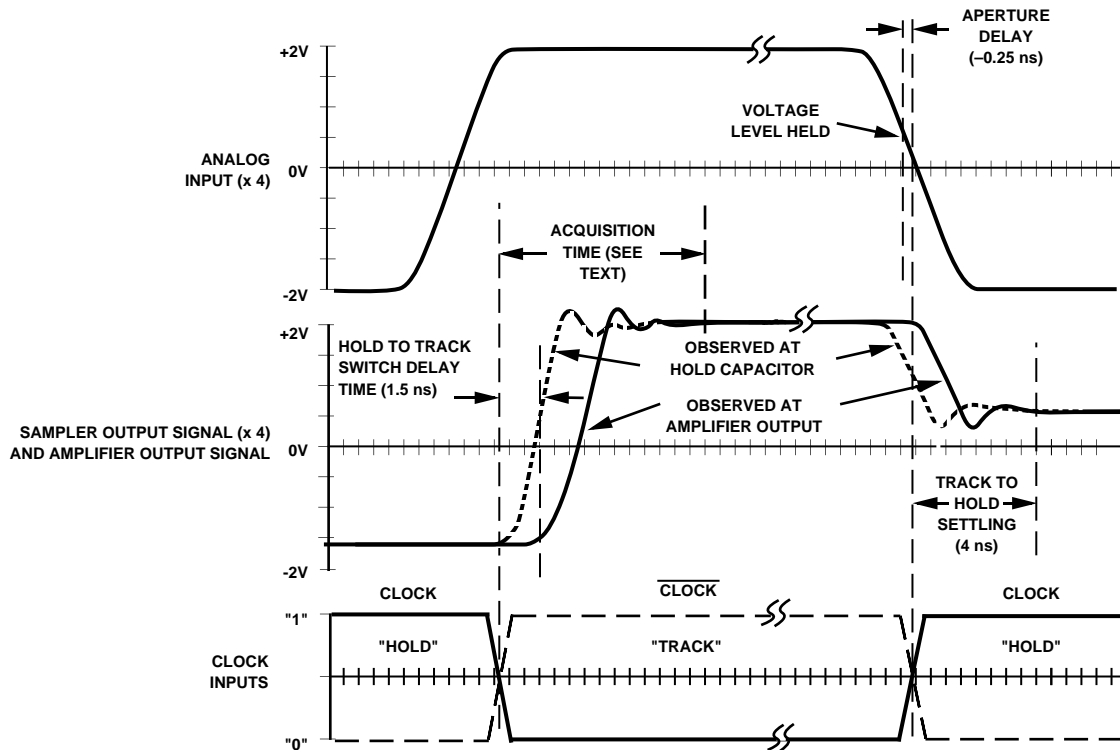

Timing Diagram (500 ps/div)

THEORY OF OPERATION

The AD9101 employs a new and unique track-and-hold architecture. Previous commercially available high speed track-and-holds used an open loop input buffer, followed by a diode bridge, hold capacitor, and output buffer (closed or open loop) with a FET device usually connected to the hold capacitor. This architecture required mixed device technology and, usually, hybrid construction. The sampling rate of these hybrids has been limited to 20 MSPS for 12-bit accuracy. Distortion generated in the front-end amplifier/bridge limited the dynamic range performance to the “mid -70 dBFS” for analog input signals of less than 10 MHz. Broadband and switch-generated noise limited the SNR of previous track-and-holds to about 70 dB.

The AD9101 is a monolithic device using a high frequency complementary bipolar process to achieve new levels of high speed precision. Its architecture completely breaks from the traditional architecture described above. The hold switch has been integrated into the first stage closed-loop buffer. This innovation provides error (distortion) correction for both the switch and buffer while still achieving slew rates representative of an open-loop design. In addition, acquisition slew current for the hold capacitor is higher than the traditional diode bridge switch configurations, removing a main contributor to the limits of maximum sampling rate, input frequency, and distortion.

The closed-loop output amplifier includes zero voltage bias current cancellation, which results in high-temperature droop rates close to those found in FET type inputs. This closed-loop amplifier inherently provides high speed loop correction and has extremely low distortion even when heavily loaded.

Extremely fast time constant linearity (7 ns to 0.01% for a 4 V output step) ensures that the output amplifier does not limit the AD9101 sampling rate or analog input frequency. (The acquisition and settling time are primarily limited only by the input sampler.) The output is transparent to the overall AD9101 hold mode distortion levels for loads as low as 50 Ω .

Full-scale track and acquisition slew rates achieved by the AD9101 are 1800 V/ μ s and 1700 V/ μ s, respectively. When combined with excellent phase margin (typically 5% overshoot), wide bandwidth, and dc gain accuracy, acquisition time to 0.01% is only 11 ns.

Acquisition Time

Acquisition time is the amount of time it takes the AD9101 to reacquire the analog input when switching from hold-to-track mode. The interval starts at the 50% clock transition point and ends when the input signal is reacquired to within a specified error band at the hold capacitor.

The hold-to-track switch delay (t_{DHT}) cannot be subtracted from this acquisition time for 12-bit performance because it is a charging time and analog output delay that occurs when moving from hold to track; this delay is typically 1.5 ns. Therefore, the track time required for the AD9101 is the acquisition time which includes t_{DHT} . Note that the acquisition time is defined as the settled voltage at the hold capacitor and does not include the delay and settling time of the output amplifier. The example in Figure 1 illustrates why the output amplifier does not contribute to the overall acquisition time.

The exaggerated illustration in Figure 1 shows that V_{HC} has settled to within x% of its final value, but V_{OUT} (due to slew rate limitations, finite BW, power supply ringing, etc.) has not settled

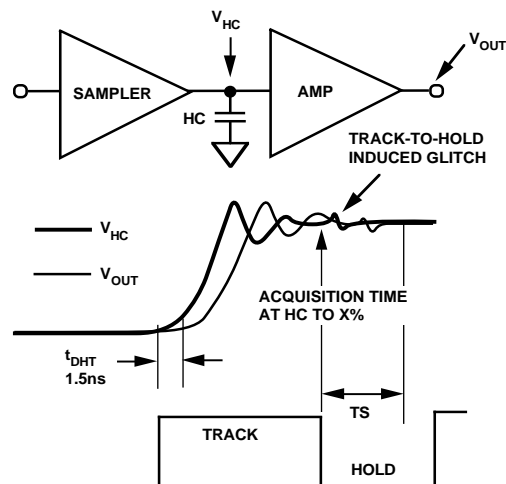

Figure 1. Acquisition Time at Hold Capacitor

during the track time. However, since the output amplifier always “tracks” the front end circuitry, it “catches up” and directly superimposes itself (less about 500 ps of analog delay) to V_{HC} . Since the small signal settling time of the output amplifier can be about 1.2 ns to ± 1 mV, and is significantly less than the hold time, acquisition time should be referenced to the hold capacitor.

Most of the hold settling time and output acquisition time are due to the sampler and the switch network. (Output acquisition time is as seen on a scope at the output. This is typically 1.7 ns longer than actual acquisition time.) For track time, the output amplifier contributes only about 5 ns of the total; in hold mode, it contributes 1.7 ns (as stated above).

A stricter definition of acquisition would actually include both the acquisition and track-to-hold settling times to a defined accuracy. To obtain 12-bit+ distortion levels and 50 MSPS operation, the minimum recommended track and hold times are 12 ns and 8 ns, respectively. To drive an 8-bit flash converter (such as the AD9002) with a 2 V p-p full-scale input, hold time to 1 LSB accuracy will be limited primarily by the aperture time of the encoder, rather than by the AD9101. This makes it possible to reduce track time to as little as 5 ns, with hold time chosen to optimize the encoder’s performance.

Though acquisition time and track-to-hold settling time to 1/2 LSB (0.4%) accuracy are 6 ns and 4 ns respectively, it is still possible to achieve -45 dB SNR performance at clock speeds to 125 MSPS. This is because the settling error is roughly proportional to the signal level and is partially cancelled due to the high phase margin of the input sampler.

Hold vs. Track Mode Distortion

In many traditional high speed, open-loop track-and-holds, track mode distortion is often much better than hold mode distortion. Track mode distortion does not include nonlinearities due to the switch network, and does not correlate to the relevant hold mode distortion. But since hold mode distortion has traditionally been omitted from manufacturer’s specification tables, users have had to discover for themselves the effective overall hold mode distortion of the combined T/H and encoder.

AD9101

The architecture of the AD9101 minimizes hold mode distortion over its specified frequency range. As an example, in track mode the worst harmonic generated for a 20 MHz input tone is typically -65 dBFS. In hold mode, under the same conditions and sampling at 50 MSPS, the worst harmonic generated is -75 dBFS. The reason is the output amplifier in hold mode has only a dc distortion relevancy. With its inherent linearity (7 ns settling to 0.01%), the output amplifier has essentially settled to its dc distortion level even for track plus hold times as short as 20 ns. For a traditional open-loop output buffer, the ac (track mode) and dc (hold mode) distortion levels are often the same.

Droop Rate

Droop rate does not necessarily affect a track-and-hold's distortion characteristics. If the droop rate is constant versus the input voltage for a given hold time, it manifests itself as a dc offset to the encoder. For the AD9101, the droop rate is typically 3 mV/ μ s. If a signal is held for 1 μ s, a subsequent encoder will see a 3 mV offset voltage. If there is no droop sensitivity to the held voltage value, the offset would be constant and "ride" on the input signal and introduce no hold-mode nonlinearities.

When droop rate varies proportionately to the level of the held voltage signal level, only a gain error is introduced to the A/D encoder. The AD9101 has a droop sensitivity to the input level of 20 mV/V μ s. For a 2 V p-p output signal, this translates to a $1\%/ \mu$ s gain error and does not cause additional distortion errors. However, hold times longer than about 500 ns can cause distortion due to the $R \times HC$ time constant at the hold capacitor. In addition, hold mode noise will increase linearly vs. hold time and thus degrade SNR performance.

Layout Considerations

For best performance results, good high speed design techniques must be applied. The component (top) side ground plane should be as large as possible; two-ounce copper cladding is preferable. All runs should be as short as possible, and decoupling capacitors must be used.

The schematic of a recommended AD9101 evaluation board is shown. (Contact factory concerning availability of assembled boards.) All 0.01 μ F decoupling capacitors should be low inductance surface mount devices (P/N 05085C103MT050 from AVX) and connected with short lead lengths to minimize stray inductance.

The 10 μ F, low frequency tantalum power supply decoupling capacitors should be located within 1.5 inches of the AD9101. The common 0.01 μ F supply capacitors can be wired together. The common power supply bus (connected to the 10 μ F capacitor and power supply source) can be routed to the underside of the board to the daisy chain wired 0.01 μ F supply capacitors.

For remote input and/or output drive applications, controlled impedances are required to minimize line reflections which will reduce signal fidelity. When capacitive and/or high impedance levels are present, the load and/or source should be physically located within approximately one inch of the AD9101. Note that a series resistance, R_S , is required if the load is greater than 6 pF. (The Recommended R_S vs. C_L chart in the "Typical Performance Section" shows values of R_S for various capacitive loads which result in no more than a 20% increase in settling time for loads up to 80 pF.) For best results when driving heavily capacitive or low resistance loads, the AD9630 buffer is strongly suggested. As much of the ground plane as possible

should be removed from around the V_{IN} and V_{OUT} pins to minimize coupling onto the analog signal path.

While a single ground plane is recommended, the analog signal and differential ECL clock ground currents follow a narrow path directly under their common voltage signal line. To reduce reflections, especially when terminations are used for transmission line efficiency, the clock, V_{IN} , and V_{OUT} signals and respective ground paths should not cross each other; if they do, unwanted coupling can result. Analog terminations should be kept as far as possible from the power supply decoupling capacitors to minimize supply current spike feedthrough.

Driving the Encode Clock

The AD9101 requires a differential ECL clock command. Due to the high gain bandwidth of the AD9101 internal switch, the input clock should have a slew rate of at least 400 V/ μ s.

To obtain maximum signal to noise performance, especially at high analog input frequencies, a low jitter clock source is required. The AD9101 clock can be driven by an AD96685, an ultrahigh speed ECL comparator with very low jitter.

Figure 2 illustrates a recommended termination for the differential encode clock inputs of the AD9101. The 40 Ω R_{LS} is required to level shift the ECL voltages more negative. This increases the linear signal range of the sampler. When the input is less than 600 mV (2.4 V p-p output), these level shift resistors are not required.

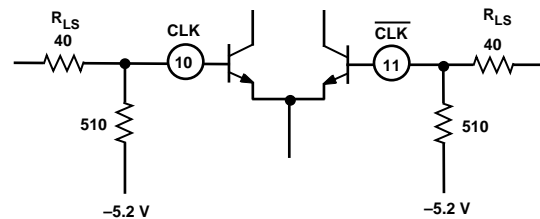

Figure 2. Recommended Encode Clock Termination

When driving the encode clock from a remote circuit via transmission lines, or where stray capacitance exceeds 2 pF, Thevenin equivalent terminations should be used (270 Ω to -5.2 V and 160 Ω to ground). For this 100 Ω equivalent termination, R_{LS} should be 20 Ω .

Driving the Analog Input

Special care must be taken to ensure that the analog input signal is not compromised before it reaches the AD9101. To obtain maximum signal to noise performance, a very low phase noise analog source is required. In addition, input filtering and/or a low harmonic signal source is necessary to maximize the spurious free dynamic range. Any required filtering should be located close to the AD9101 and away from digital lines.

Matching the AD9101 to A/D Encoders

The AD9101's analog output level may have to be offset or amplified to match the full-scale range of a given A/D converter. This can generally be accomplished by inserting an amplifier after the AD9101. For example, the AD671 is a 12-bit 500 ns monolithic ADC encoder that requires a 0 V to +5 V full-scale analog input. An AD84X series amplifier could be used to condition the AD9101 output to match the full-scale range of the AD671.

The AD9101 can perform a dc level shift function when its input is bipolar and the ADC requires a unipolar signal. The AD9002

provides a good example. It operates on a single negative supply with the input range from 0 V to -2 V. By connecting Pins 1 and 2 (RTN) to a +0.33 V level, rather than its usual ground connection, a bipolar ± 0.25 V input is shifted to 0 V to -2 V at the AD9101's output (see Figure 3 in the Applications section.)

APPLICATIONS

Because of its rapid acquisition and low distortion, the AD9101 is useful in a wide range of signal processing.

Choosing Between the AD9100 and AD9101

The first obvious difference between the AD9100 and AD9101 is sample rate. Simplistically, any high resolution system (12–16 bits) operating below 25 MSPS will use the AD9100 and 8–12 bit systems operating above 25 MSPS will use the AD9101. There are, however, some subtle characteristics of these high performance track-and-hold amplifiers that create some exceptions to these guidelines. The typical curve entitled “Dynamic Range vs. Analog Frequency” should be considered when choosing between these two high performance track-and-holds.

When speed is critical, the AD9101 should receive strong consideration, even in high resolution systems. Using a reduced signal amplitude through the AD9100 greatly reduces slew limiting effects and should also be considered when converting high frequency (up to 70 MHz) analog signals with encode rates below 25 MSPS.

Sampler for Flash ADC

Flash ADCs typically suffer degradation of dynamic range as signal frequency increases. The AD9101 was designed specifically for the purpose of boosting this performance and allowing users to obtain maximum performance with flash ADCs. Figure 3 shows the block diagram and timing relationship for an 8-bit, 125 MSPS converter.

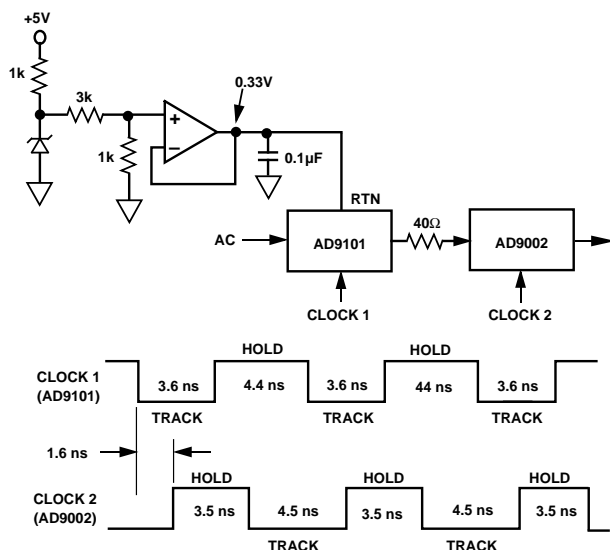

Figure 3. AD9101 with 8-Bit, 125 MSPS Flash

Figure 4 contrasts performance of the flash converter alone vs. the circuit of Figure 3.

Figures 5 and 6 show the block diagrams and dynamic range improvement when the AD9101 is used ahead of an 10-bit, 75 MSPS flash converter. The AD9630 is not required if the input frequency is limited to 40 MHz.

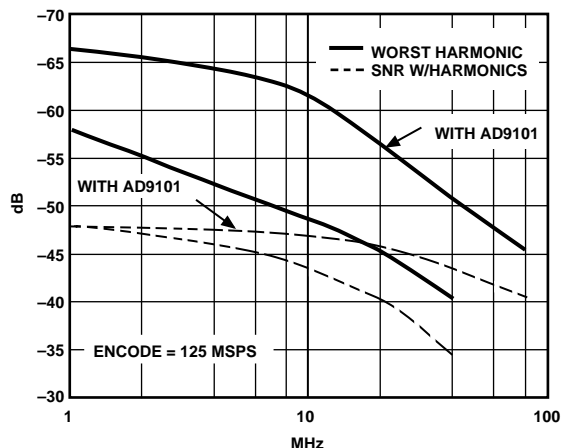

Figure 4. AD9002 Dynamic Range With and Without AD9101

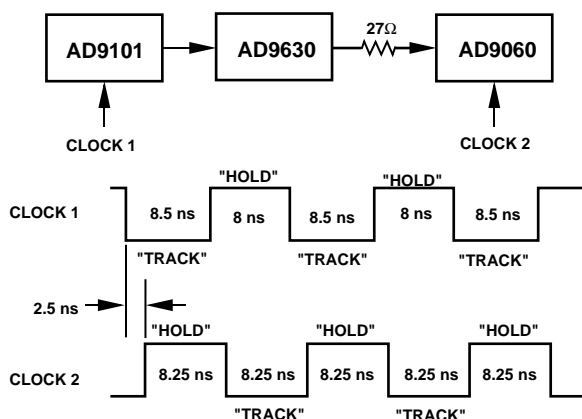

Figure 5. AD9101 with 10-Bit, 75 MSPS ADC

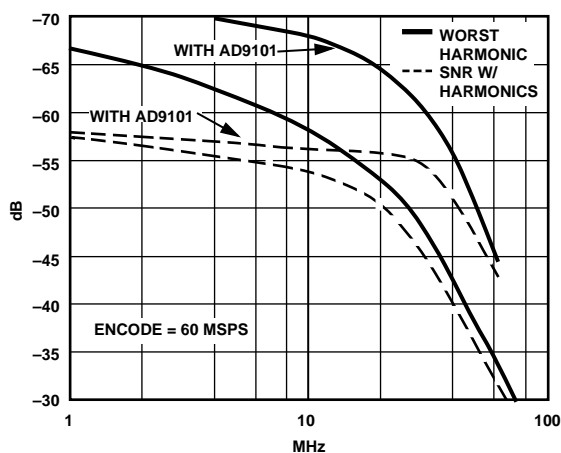

Figure 6. AD9060 Dynamic Performance With and Without AD9101

AD9101

Deglitcher

Many recently announced video-speed digital-to-analog converters feature very low glitch impulse. This is the result of design emphasis on spurious free dynamic range (SFDR), a key spec for the emerging direct digital synthesis (DDS) market. These DACs have extremely low spurs and often do not require deglitching.

Although their specs are impressive, these DACs may suffer harmonic distortion, especially at higher clock rates. Therefore, a deglitcher using the AD9101 can improve SFDR in some cases. Figure 7 illustrates the block diagram for deglitching an AD9713, 12-bit DAC.

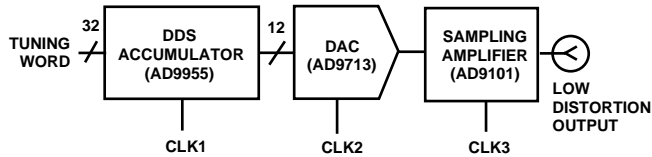

Figure 7. Deglitcher Block Diagram

IF-to-Digital Conversion

Traditional receivers with information encoded with in phase (I) and quadrature (Q) signals comprise extensive analog signal processing ahead of the pair of ADCs.

This I-Q demodulation in the analog domain requires precise gain and phase matching as well as close matching of the ADCs. This leads to high cost both in materials and labor to attain the desired performance. Digital front end designers have paid the cost for these components because ADCs have limited the dynamic range at higher signal frequencies.

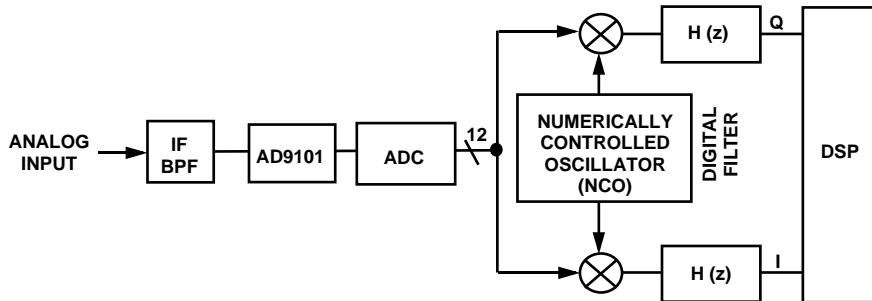

Figure 9. Direct IF-to-Digital

Thus, the final IF signal was mixed with quadrature signals from the final LO. The two resultant baseband signals representing I and Q were digitized by independent converters.

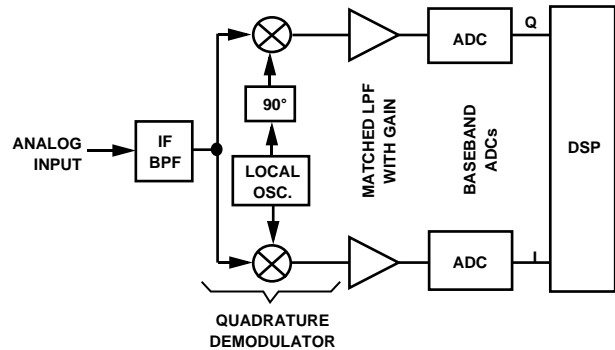
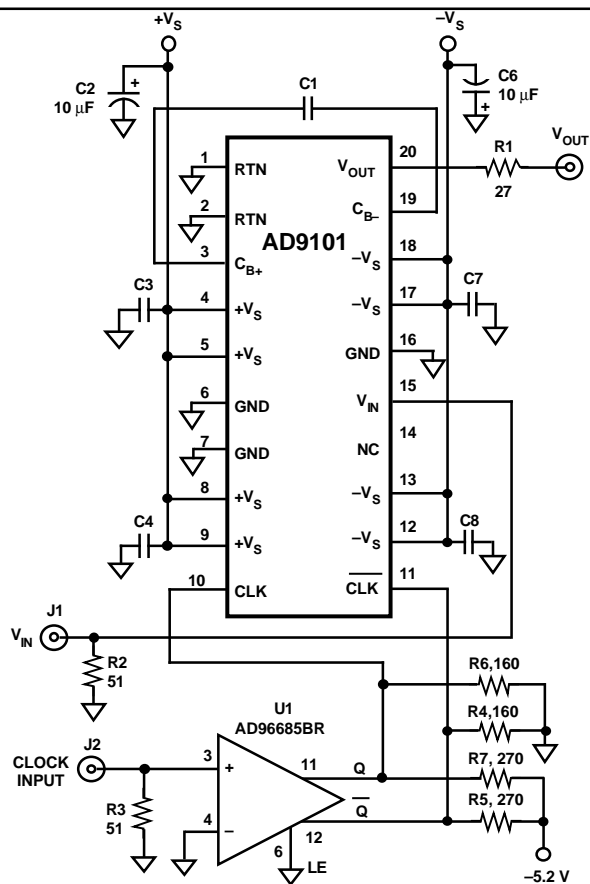

Figure 8. Traditional I-Q Demodulation

This method, shown in block form in Figure 8, relies heavily on accuracy of the phase of the analog I and Q signals applied to the ADCs. As little as 0.5° of phase error can reduce system dynamic range by 6 dB or more.

Using the bandwidth and low distortion of the AD9101 greatly simplifies the analog front end and allows signal processing to be done in the digital domain which is more predictable and less susceptible to environmental changes. The simplified front end is illustrated in Figure 9.

This configuration removes the burden from the analog section. The AD9101 expands the dynamic range of the ADC into the IF bandwidth, allowing straightforward digital algorithms to demodulate the I and Q data.



- NOTES
1. ALL CAPACITORS ARE 0.01 μF UNLESS OTHERWISE DESIGNATED. SURFACE-MOUNT CAPS PREFERRED.
 2. R1 SHOULD BE SELECTED BASED ON C_L AND MAY BE SHORTED FOR CAPACITIVE LOADS OF LESS THAN 6 pF.
 3. C1 SHOULD A LOW INDUCTANCE 0.01 μF WITH CIRCUIT LEADS AS SHORT AS POSSIBLE.
 4. PINOUTS FOR AD9101 AND AD96685 ARE FOR SOIC.

Evaluation Circuit

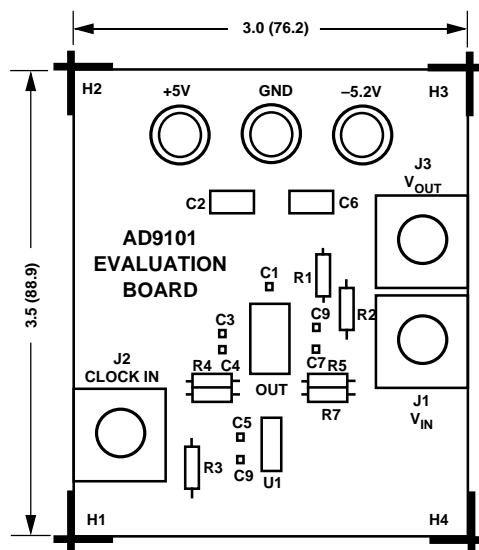

AD9101 Layout

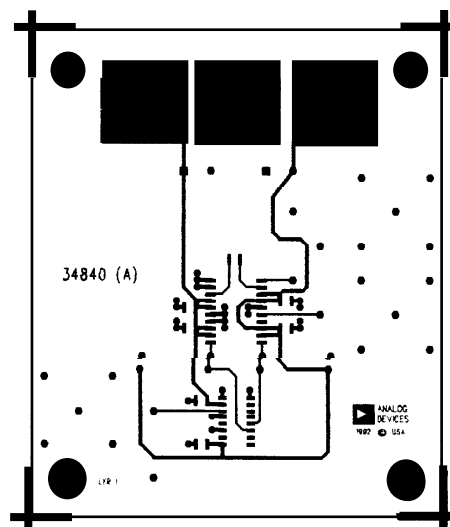

Component Side

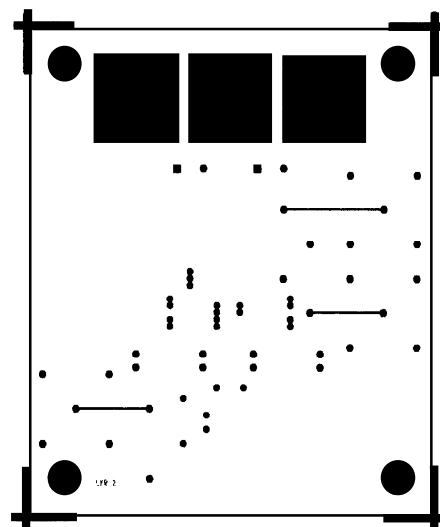

Ground Plane Bottom

EVALUATION BOARD ORDERING GUIDE

Part Number	Description
AD9101/PCB	Fully Populated and Tested Evaluation Board
AD9101/PWB	Printed Circuit Board without Components

AD9101 – Typical Performance Curves

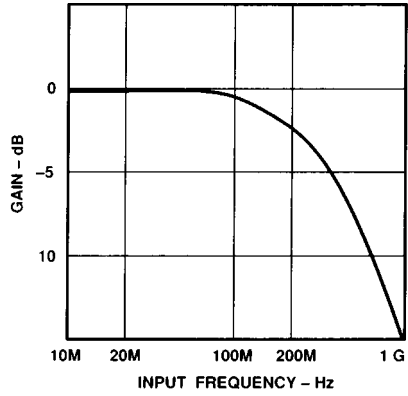

Gain vs. Frequency (Track Mode)

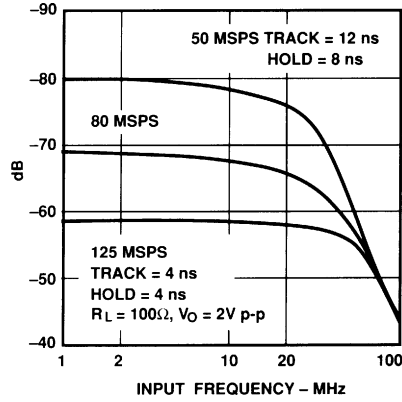

Hold Mode Distortion vs. Analog Input Frequency

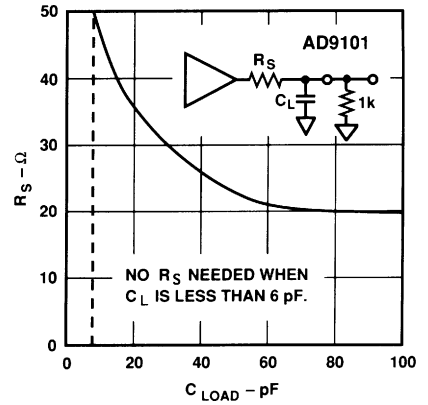

Recommended R_S vs. C_L for Optimal Settling Time

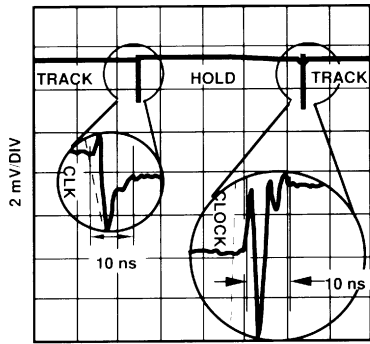

Track-to-Hold-to-Track Transients

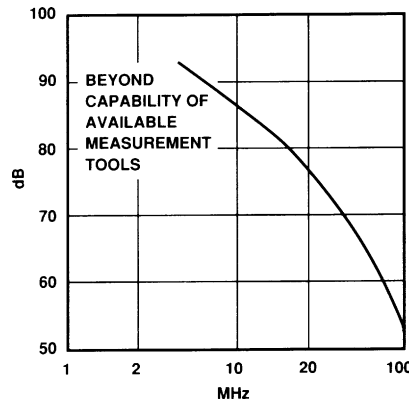

Feedthrough vs. Input Frequency

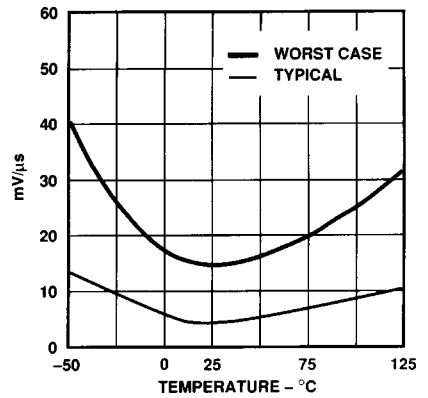

Droop Rate vs. Temperature

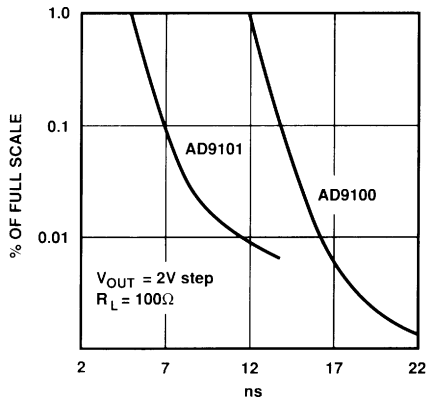

Settling Tolerance vs. Acquisition Time

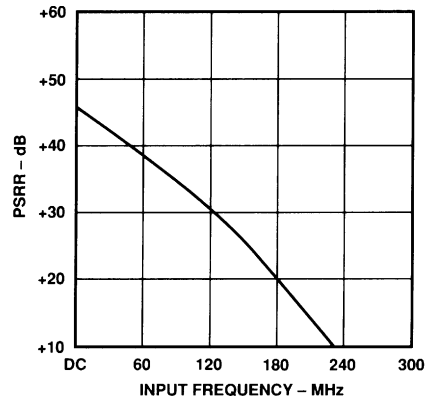

Power Supply Rejection Ratio vs. Frequency

OUTLINE DIMENSIONS

Dimensions are shown in inches and (mm).

20-Pin SOIC

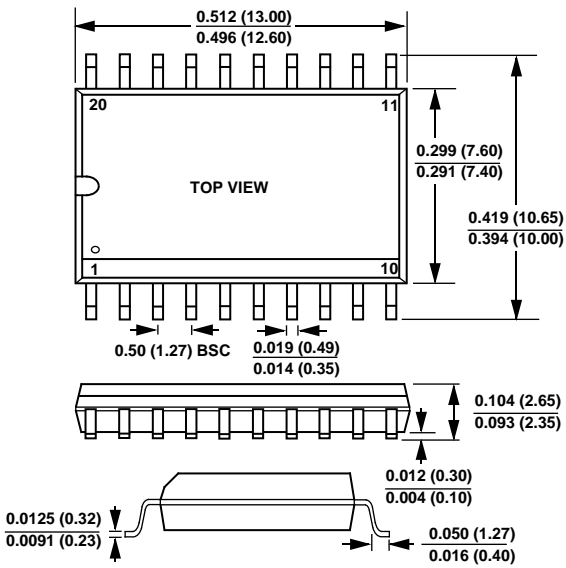

20-Contact LCC

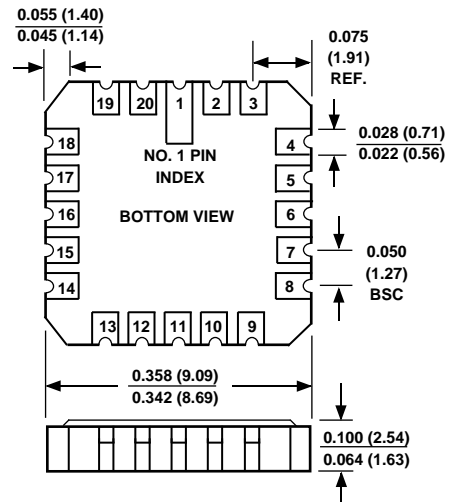



LittleDiode supplies new, hard to find or obsolete electronic components and semiconductors all over the world.

With over two million different components listed you are sure to find the part you need.

Feel free to visit us today at our online store:

LittleDiode.com

Looking forward to providing you with the best possible service.