

FEATURES

170 MSPS Update Rate
TTL/High-Speed CMOS-Compatible Inputs
Wideband SFDR: 66 dB @ 2 MHz/50 dB @ 65 MHz
Pin-Compatible, Lower Cost Replacement for Industry Standard AD9721 DAC
Low Power: 439 mW @ 170 MSPS
Fast Settling: 3.8 ns to 1/2 LSB
Internal Reference
Two Package Styles: 28-Lead SOIC and SSOP

APPLICATIONS

Digital Communications
Direct Digital Synthesis
Waveform Reconstruction
High Speed Imaging
5 MHz–65 MHz HFC Upstream Path

GENERAL DESCRIPTION

The AD9731 is a 10-bit, 170 MSPS, bipolar D/A converter that is optimized to provide high dynamic performance, yet offer lower power dissipation and more economical pricing than afforded by previous bipolar high performance DAC solutions. The AD9731 was designed primarily for demanding communications systems applications where wideband spurious-free dynamic range (SFDR) requirements are strenuous and could previously only be met by using a high performance DAC such as the industry-standard AD9721. The proliferation of digital communications into basestation and high volume subscriber-end markets has created a demand for excellent DAC performance delivered at reduced levels of power dissipation and cost. The AD9731 is the answer to that demand.

FUNCTIONAL BLOCK DIAGRAM

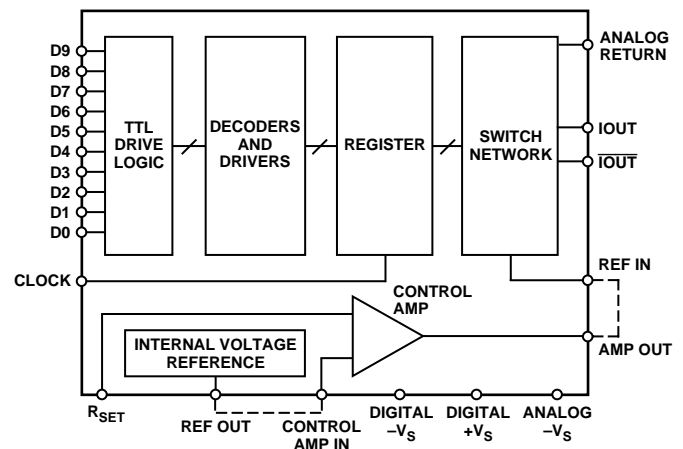

Optimized for direct digital synthesis (DDS) waveform reconstruction, the AD9731 provides 50 dB of wideband harmonic suppression over a dc-to-65 MHz analog output bandwidth. This signal bandwidth addresses the transmit spectrum in many of the emerging digital communications applications where signal purity is critical. Narrowband, the AD9731 provides an SFDR of greater than 79 dB. This excellent wideband and narrowband ac performance, coupled with a lower pricing structure, make the AD9731 the optimum high performance DAC value.

The AD9731 is packaged in 28-lead SOIC (same footprint as the industry standard AD9721) and super space-saving 28-lead SSOP; both are specified to operate over the extended industrial temperature range of -40°C to $+85^{\circ}\text{C}$.

REV. A

Information furnished by Analog Devices is believed to be accurate and reliable. However, no responsibility is assumed by Analog Devices for its use, nor for any infringements of patents or other rights of third parties which may result from its use. No license is granted by implication or otherwise under any patent or patent rights of Analog Devices.

AD9731—SPECIFICATIONS

($+V_S = +5\text{ V}$, $-V_S = -5.2\text{ V}$, $\text{CLOCK} = 125\text{ MHz}$, $R_{\text{SET}} = 1.96\text{ k}\Omega$ for $20.4\text{ mA } I_{\text{OUT}}$,
 $V_{\text{REF}} = -1.25\text{ V}$, unless otherwise noted.)

Parameter	Temp	Test Level	Min	Typ	Max	Units
RESOLUTION				10		Bits
THROUGHPUT RATE	+25°C	IV	165	170		MHz
DC ACCURACY						
Differential Nonlinearity	+25°C	I		0.25	1	LSB
	Full	VI		0.35	1.5	LSB
Integral Nonlinearity	+25°C	I		0.6	1	LSB
	Full	VI		0.7	1.5	LSB
INITIAL OFFSET ERROR						
Zero-Scale Offset Error	+25°C	I		35	70	μA
	Full	VI		40	100	μA
Full-Scale Gain Error ¹	+25°C	I		2.5	5	% FS
	Full	VI		2.5	5	% FS
Offset Drift Coefficient		V		0.04		$\mu\text{A}/^\circ\text{C}$
REFERENCE/CONTROL AMP						
Internal Reference Voltage ²	+25°C	I	-1.35	-1.25	-1.15	V
Internal Reference Voltage Drift	Full	IV		100		$\mu\text{V}/^\circ\text{C}$
Internal Reference Output Current ³	Full	VI	-50		+500	μA
Amplifier Input Impedance	+25°C	V		50		$\text{k}\Omega$
Amplifier Bandwidth	+25°C	V		2.5		MHz
REFERENCE INPUT ⁴						
Reference Input Impedance	+25°C	V		4.6		$\text{k}\Omega$
Reference Multiplying Bandwidth ⁵	+25°C	V		75		MHz
OUTPUT PERFORMANCE						
Output Current ^{4, 6}	+25°C	V		20		mA
Output Compliance	+25°C	IV	-1.5		+3	V
Output Resistance	+25°C	V		240		Ω
Output Capacitance	+25°C	V		5		pF
Voltage Settling Time to 1/2 LSB (t_{ST}) ⁷	+25°C	V		3.8		ns
Propagation Delay (t_{PD}) ⁸	+25°C	V		2.9		ns
Glitch Impulse ⁹	+25°C	V		4.1		pVs
Output Slew Rate ¹⁰	+25°C	V		400		$\text{V}/\mu\text{s}$
Output Rise Time ¹⁰	+25°C	V		1		ns
Output Fall Time ¹⁰	+25°C	V		1		ns
DIGITAL INPUTS						
Input Capacitance	Full	IV		2		pF
Logic "1" Voltage	Full	VI	2.0			V
Logic "0" Voltage	Full	VI			0.8	V
Logic "1" Current	+25°C	VI		8	50	μA
Logic "0" Current	+25°C	VI		30	100	μA
Minimum Data Setup Time (t_{S}) ¹¹	+25°C	IV		1.2	2	ns
	Full	IV		1.5	2.5	ns
Minimum Data Hold Time (t_{H}) ¹²	+25°C	IV		0.1	1.0	ns
	Full	IV		0.1	1.0	ns
Clock Pulsewidth Low (p_{WMIN})	+25°C	IV	2			ns
Clock Pulsewidth High (p_{WMAX})	+25°C	IV	2			ns
SFDR PERFORMANCE (Wideband) ¹³						
2 MHz A_{OUT}	+25°C	V		66		dB
10 MHz A_{OUT}	+25°C	V		62		dB
20 MHz A_{OUT}	+25°C	V		61		dB
40 MHz A_{OUT}	+25°C	V		55		dB
65 MHz A_{OUT} (Clock = 170 MHz)	+25°C	V		50		dB
70 MHz A_{OUT} (Clock = 170 MHz)	+25°C	V		47		dB

Parameter	Temp	Test Level	Min	Typ	Max	Units
SFDR PERFORMANCE (Narrowband)¹³						
2 MHz; 2 MHz Span	+25°C	V		79		dB
25 MHz; 2 MHz Span	+25°C	V		61		dB
10 MHz; 5 MHz Span (Clock = 170 MHz)	+25°C	V		73		dB
INTERMODULATION DISTORTION¹⁴						
F1 = 800 kHz, F2 = 900 kHz	+25°C	V		58		dB
POWER SUPPLY¹⁵						
Digital -V Supply Current	+25°C	I		27	37	mA
	Full	VI		27	42	mA
Analog -V Supply Current	+25°C	I		45	53	mA
	Full	VI		45	66	mA
Digital +V Supply Current	+25°C	I		13	20	mA
	Full	VI		15	22	mA
Power Dissipation	+25°C	V		439		mW
	Full	V		449		mW
PSRR	+25°C	V		100		μA/V

NOTES

- ¹Measured as an error in ratio of full-scale current to current through R_{SET} (640 μA nominal); ratio is nominally 32. DAC load is virtual ground.
- ²Internal reference voltage is tested under load conditions specified in Internal Reference Output current specification.
- ³Internal reference output current defines load conditions applied during Internal Reference Voltage test.
- ⁴Full-scale current variations among devices are higher when driving REFERENCE IN directly.
- ⁵Frequency at which a 3 dB change in output of DAC is observed; R_L = 50 Ω; 100 mV modulation at midscale.
- ⁶Based on I_{FS} = 32 (CONTROL AMP IN/R_{SET}) when using internal control amplifier. DAC load is virtual ground.
- ⁷Measured as voltage settling at midscale transition to ±0.1%; R_L = 50 Ω.
- ⁸Measured from 50% point of rising edge of CLOCK signal to 1/2 LSB change in output signal.
- ⁹Peak glitch impulse is measured as the largest area under a single positive or negative transient.
- ¹⁰Measured with R_L = 50 Ω and DAC operating in latched mode.
- ¹¹Data must remain stable for specified time prior to rising edge of CLOCK.
- ¹²Data must remain stable for specified time after rising edge of CLOCK.
- ¹³SFDR is defined as the difference in signal energy between the full-scale fundamental signal and worst case spurious frequencies in the output spectrum window. The frequency span is dc-to-Nyquist unless otherwise noted.
- ¹⁴Intermodulation distortion is the measure of the sum and difference products produced when a two-tone input is driven into the DAC. The distortion products created will manifest themselves at sum and difference frequencies of the two tones.
- ¹⁵Supply voltages should remain stable within ±5% for nominal operation.

Specifications subject to change without notice.

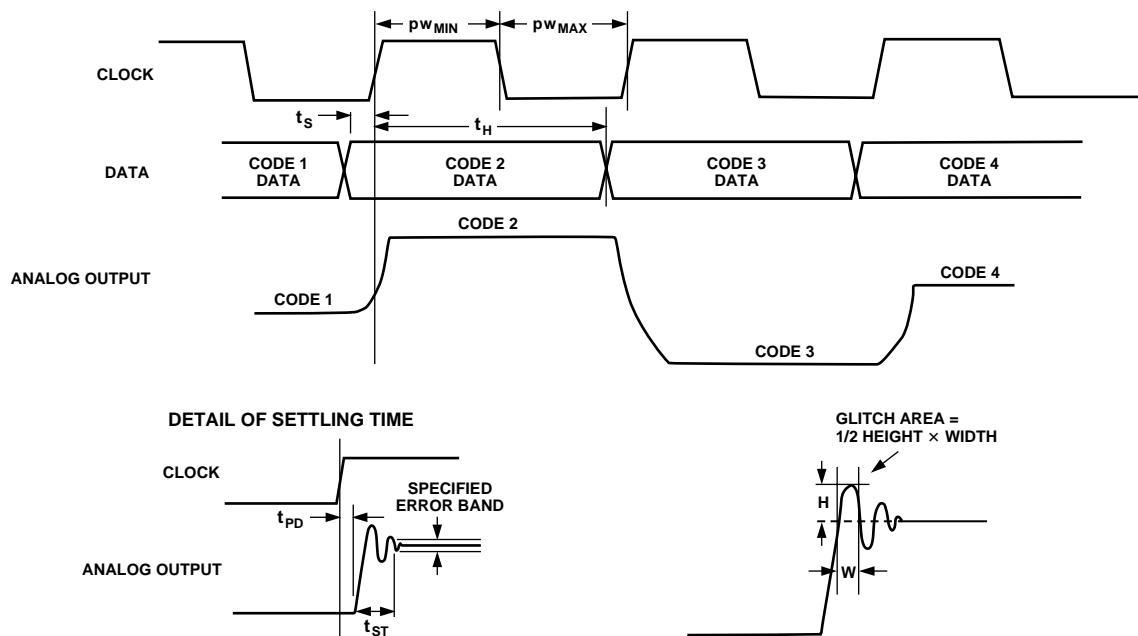

Figure 1. Timing Diagrams

AD9731

ABSOLUTE MAXIMUM RATINGS*

Analog Output	$-V_S$ to $+V_S$
$+V_S$	+6 V
Digital Inputs	-0.7 V to $+V_S$
$-V_S$	-7 V
Analog Output Current	30 mA
Control Amplifier Input Voltage Range	0 V to -4 V
Reference Input Voltage Range	0 V to $-V_S$
Maximum Junction Temperature	+150°C
Operating Temperature Range	-40°C to +85°C
Internal Reference Output Current	500 μ A
Lead Temperature (10 sec Soldering)	+300°C
Storage Temperature	-65°C to +165°C
Control Amplifier Output Current	± 2.5 mA

*Absolute maximum ratings are limiting values, to be applied individually, and beyond which the serviceability of the circuit may be impaired. Functional operability under any of these conditions is not necessarily implied. Exposure of absolute maximum rating conditions for extended periods of time may affect device reliability.

EXPLANATION OF TEST LEVELS

Test Level	Definition
I	100% Production Tested.
II	The parameter is 100% production tested at +25°C; sampled at temperature production.
III	Sample Tested Only.
IV	Parameter is guaranteed by design and characterization testing.
V	Parameter is a typical value only.
VI	All devices are 100% production tested at +25°C; guaranteed by design and characterization testing for industrial temperature range devices.

ORDERING GUIDE

Model	Temperature Range	Package Description	Package Options
AD9731BR	-40°C to +85°C	28-Lead Wide Body (SOIC)	R-28
AD9731BRS	-40°C to +85°C	28-Lead Shrink Small (SSOP)	RS-28
AD9731-PCB	0°C to +70°C	PCB	

CAUTION

ESD (electrostatic discharge) sensitive device. Electrostatic charges as high as 4000 V readily accumulate on the human body and test equipment and can discharge without detection. Although the AD9731 features proprietary ESD protection circuitry, permanent damage may occur on devices subjected to high energy electrostatic discharges. Therefore, proper ESD precautions are recommended to avoid performance degradation or loss of functionality.



PIN FUNCTION DESCRIPTION

Pin #	Pin Name	Pin Description
1	D9(MSB)	Most significant data bit of digital input word.
2–9	D8–D1	Eight bits of 10-bit digital input word.
10	D0(LSB)	Least significant data bit of digital input word.
11	CLOCK	TTL-compatible edge-triggered latch enable signal for on-board registers.
12, 13	NC	No internal connection to this pin.
14	DIGITAL +V _S	+5 V supply voltage for digital circuitry.
15, 18, 28	GND	Converter Ground.
16	DIGITAL –V _S	–5.2 V supply voltage for digital circuitry.
17	R _{SET}	Connection for external reference set resistor; nominal 1.96 k Ω . Full-scale output current = 32 (Control Amp in V/R _{SET}).
19	ANALOG RETURN	Analog Return. This point and the reference side of the DAC load resistors should be connected to the same potential (nominally ground).
20	I _{OUT}	Analog current output; full-scale current occurs with a digital word input of all “1s.” With external load resistor, output voltage = I _{OUT} (R _{LOAD} R _{INTERNAL}). R _{INTERNAL} is nominally 240 Ω .
21	I _{OUTB}	Complementary analog current output; full-scale current occurs with a digital word input of all “0s.”
22	ANALOG –V _S	Negative analog supply, nominally –5.2 V.
23	REF IN	Normally connected to CONTROL AMP OUT (Pin 24). Direct line to DAC current source network. Voltage changes (noise) at this point have a direct effect on the full-scale output current of the DAC. Full-scale current output = 32 (CONTROL AMP IN/R _{SET}) when using the internal amplifier. DAC load is virtual ground.
24	CONTROL AMP OUT	Normally connected to REF IN (Pin 23). Output of internal control amplifier which provides a reference for the current switch network.
25	REF OUT	Normally connected to CONTROL AMP IN (Pin 26). Internal voltage reference, nominally –1.25 V.
26	CONTROL AMP IN	Normally connected to REF Out (Pin 25) if not connected to external reference.
27	DIGITAL –V _S	Negative digital supply, nominally –5.2 V.

PIN CONFIGURATION

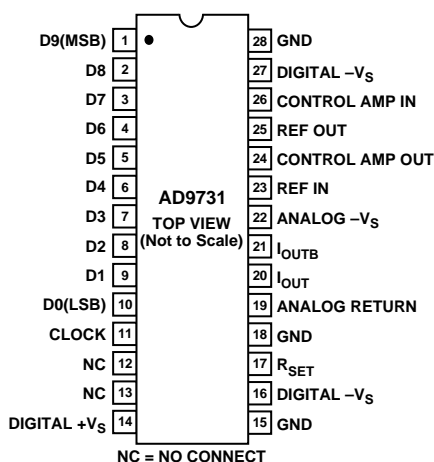

AD9731—Typical Performance Characteristics

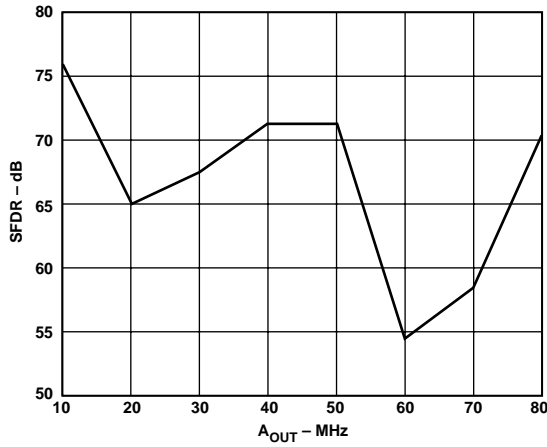

Figure 2. Narrowband SFDR (Clock = 170 MHz) vs. A_{OUT} Frequency

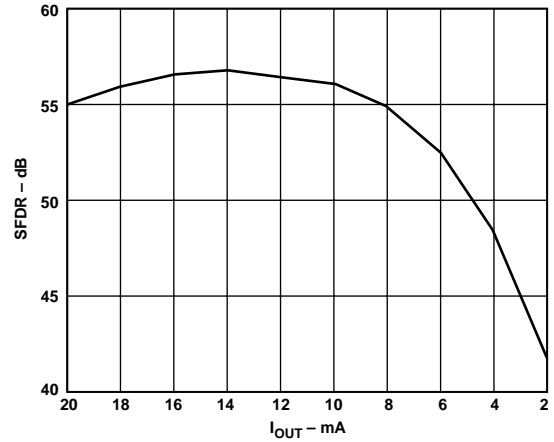

Figure 5. SFDR vs. I_{OUT} (Clock = 125 MHz/A_{OUT} = 40 MHz)

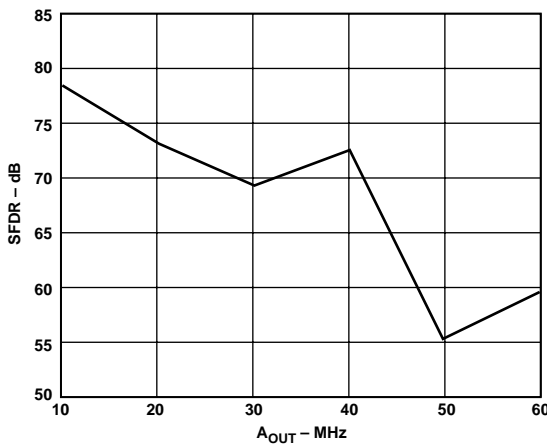

Figure 3. Narrowband SFDR (Clock = 125 MHz) vs. A_{OUT} Frequency

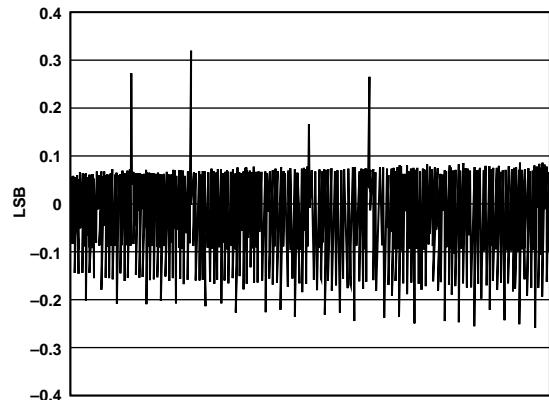

Figure 6. Typical Differential Nonlinearity Performance (DNL)

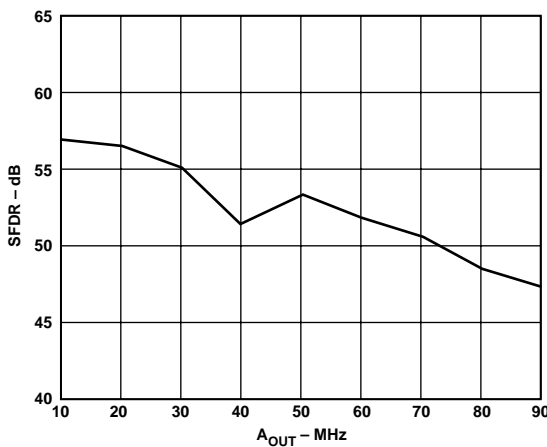

Figure 4. Wideband SFDR (170 MHz Clock) vs. A_{OUT}

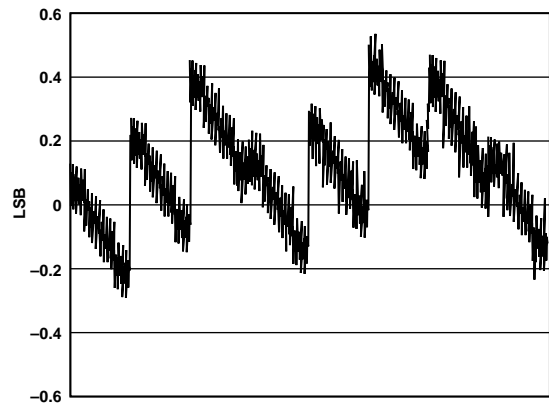

Figure 7. Typical Integral Nonlinearity Performance (INL)

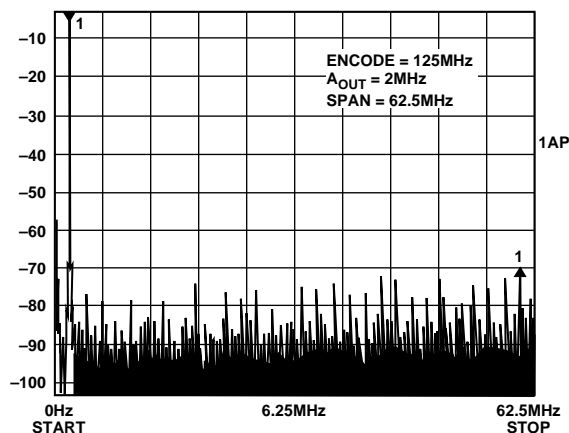

Figure 8. Wideband SFDR 2 MHz A_{OUT} ; 125 MHz Clock

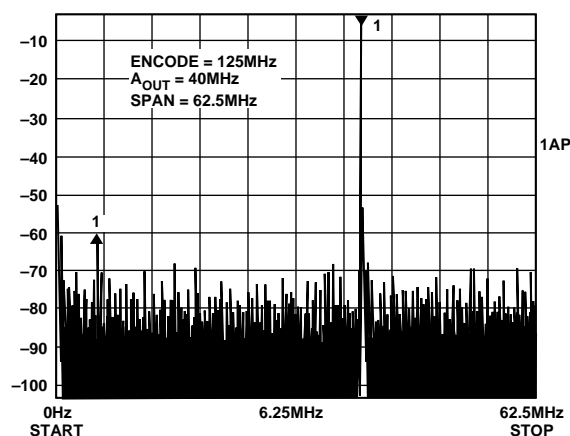

Figure 11. Wideband SFDR 40 MHz A_{OUT} ; 125 MHz Clock

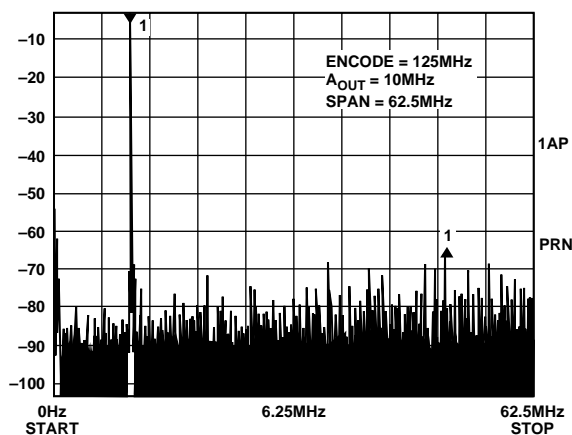

Figure 9. Wideband SFDR 10 MHz A_{OUT} ; 125 MHz Clock

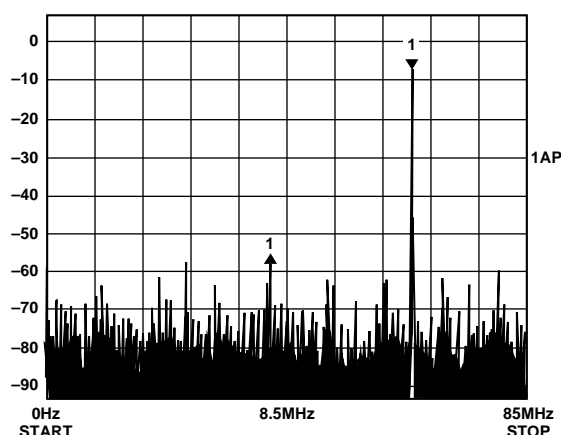

Figure 12. Wideband SFDR 65 MHz A_{OUT} ; 170 MHz Clock

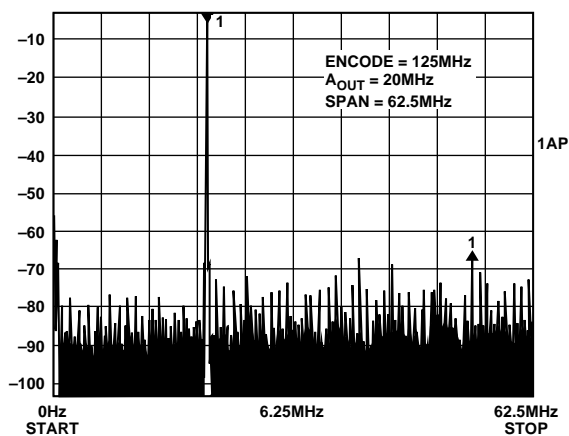

Figure 10. Wideband SFDR 20 MHz A_{OUT} ; 125 MHz Clock

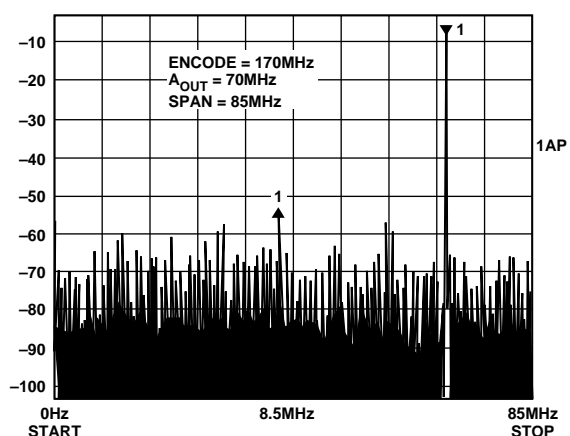

Figure 13. Wideband SFDR 70 MHz A_{OUT} ; 170 MHz Clock

AD9731

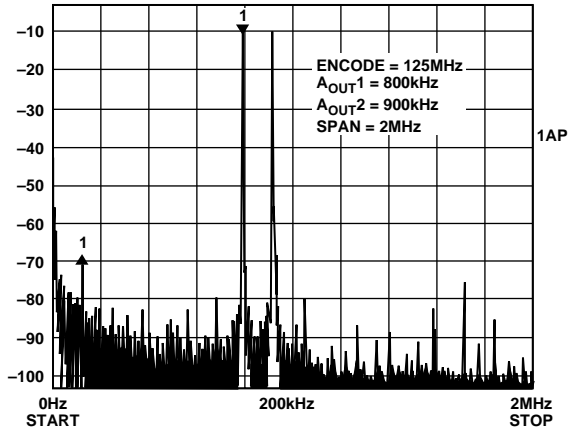

Figure 14. Wideband Intermodulation Distortion
 $F_1 = 800 \text{ kHz}$; $F_2 = 900 \text{ kHz}$; 125 MHz Clock; $\text{Span} = 2 \text{ MHz}$

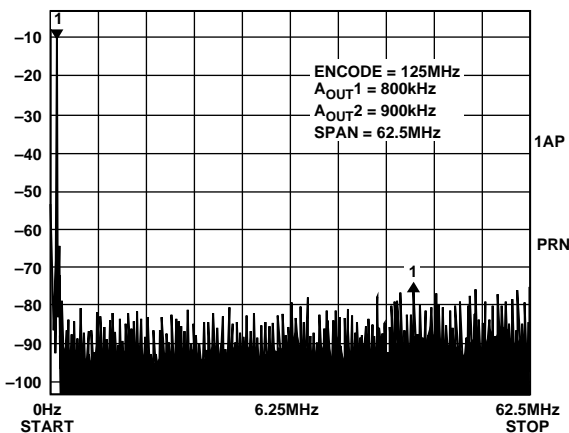

Figure 15. Wideband Intermodulation Distortion $F_1 = 800 \text{ kHz}$; $F_2 = 900 \text{ kHz}$; 125 MHz Clock; $\text{Span} = 62.5 \text{ MHz}$

THEORY AND APPLICATIONS

The AD9731 high speed digital-to-analog converter utilizes most significant bit decoding and segmentation techniques to reduce glitch impulse and deliver high dynamic performance on lower power consumption than previous bipolar DAC technologies.

The design is based on four main subsections: the decoder/driver circuits, the edge-triggered data register, the switch network and the control amplifier. An internal bandgap reference is included to allow operation of the device with minimum external support components.

Digital Inputs/Timing

The AD9731 has TTL/high speed CMOS-compatible single-ended inputs for data inputs and clock. The switching threshold is +1.5 V.

In the decoder/driver section, the three MSBs are decoded to seven “thermometer code” lines. An equalizing delay is included for the seven least significant bits and the clock signals. This delay minimizes data skew and data setup and hold times at the register inputs.

The on-board register is rising-edge triggered and should be used to synchronize data to the current switches by applying a pulse with proper data setup and hold times as shown in the timing diagram. Although the AD9731 is designed to provide isolation of the digital inputs to the analog output, some coupling of digital transitions is inevitable. Digital feedthrough can be minimized by forming a low-pass filter at the digital input by using a resistor in series with the capacitance of each digital input. This common high speed DAC application technique has the effect of isolating digital input noise from the analog output.

References

The internal bandgap reference, control amplifier and reference input are pinned out to provide maximum user flexibility in configuring the reference circuitry for the AD9731. When using the internal reference, REF OUT (Pin 25) should be connected to CONTROL AMP IN (Pin 26). CONTROL AMP OUT (Pin 24) should be connected to REF IN (Pin 23). A $0.1 \mu\text{F}$ ceramic capacitor connected from Pin 23 to Analog $-V_S$ (Pin 22) improves settling time by decoupling switching noise from the current sink baseline. A reference current cell provides feedback to the control amplifier by sinking current through R_{SET} (Pin 17).

Full-scale current is determined by CONTROL AMP IN and R_{SET} according to the following equation:

$$I_{OUT}(\text{FS}) = 32(\text{CONTROL AMP IN}/R_{SET})$$

The internal reference is nominally -1.25 V with a tolerance of $\pm 8\%$ and typical drift over temperature of $100 \text{ ppm}/^\circ\text{C}$. If greater accuracy or temperature stability is required, an external reference can be used. The AD589 reference features $10 \text{ ppm}/^\circ\text{C}$ drift over the 0°C to $+70^\circ\text{C}$ temperature range.

Two modes of multiplying operation are possible with the AD9731. Signals with bandwidths up to 2.5 MHz and input swings from -0.6 V to -1.2 V can be applied to the CONTROL AMP IN pin as shown in Figure 16. Because the control amplifier is internally compensated, the $0.1 \mu\text{F}$ capacitor discussed above can be reduced to maximize the multiplying bandwidth. However, it should be noted that output settling time, for changes in the digital word, will be degraded.

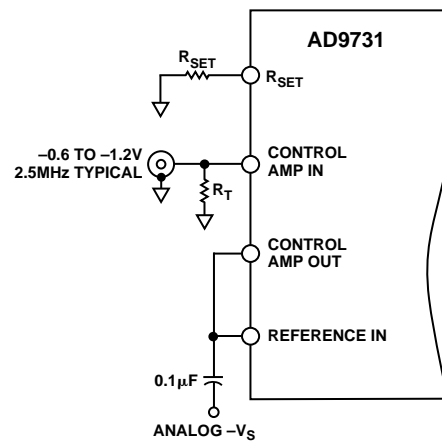

Figure 16. Low Frequency Multiplying Circuit

The REFERENCE IN pin can also be driven directly for wider bandwidth multiplying operation. The analog signal for this mode of operation must have a signal swing in the range of -3.3 V to -4.25 V . This can be implemented by capacitively coupling into REFERENCE IN a signal with a dc bias of -3.3 V ($I_{OUT} \approx 22.5\text{ mA}$) to -4.25 V ($I_{OUT} \approx 3\text{ mA}$), as shown in Figure 17, or by dividing REFERENCE IN with a low impedance op amp whose signal swing is limited to the stated range.

NOTE: When using an external reference, the external reference voltage must be applied prior to applying $-V_S$.

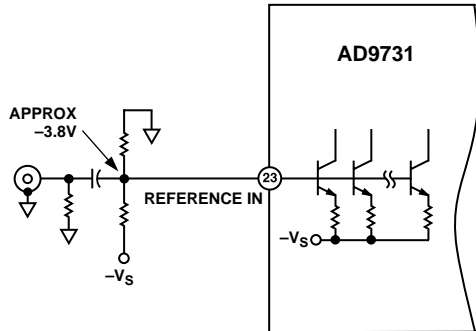

Figure 17. Wideband Multiplying Circuit

Analog Output

The switch network provides complementary current outputs I_{OUT} and I_{OUTB} . The design of the AD9731 is based on statistical current source matching, which provides a 10-bit linearity without trim. Current is steered to either I_{OUT} or I_{OUTB} in proportion to the digital input word. The sum of the two currents is always equal to the full-scale output current minus 1 LSB. The current can be converted to a voltage by resistive loading as shown in the block diagram. Both I_{OUT} and I_{OUTB} should be equally loaded for best overall performance. The voltage that is developed is the product of the output current and the value of the load resistor.

An operational amplifier can also be used to perform the I-to-V conversion of the DAC output. Figure 18 shows an example of a circuit that uses the AD9617, a high speed, current feedback amplifier. The resistor values in Figure 18 provide a 4.096 V swing, centered at ground, at the output of the AD9617 amplifier.

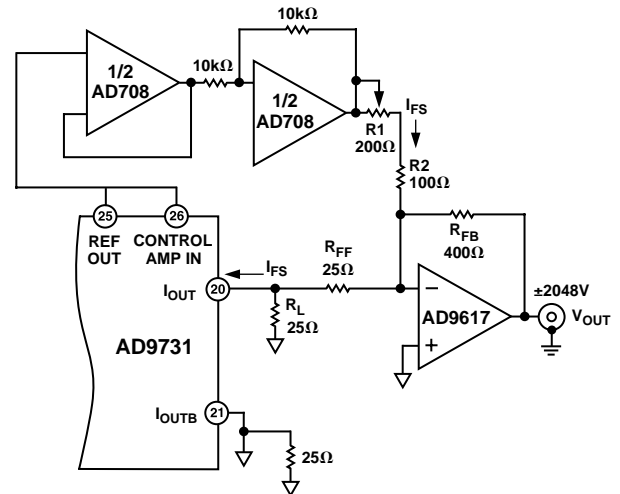

Figure 18. I-to-V Conversion Using a Current Feedback Amplifier

EVALUATION BOARD

The performance characteristics of the AD9731 make it ideally suited for direct digital synthesis (DDS) and other waveform synthesis applications. The AD9731 evaluation board provides a platform for analyzing performance under optimum layout conditions. The AD9731 also provides a reference for high speed circuit board layout techniques.

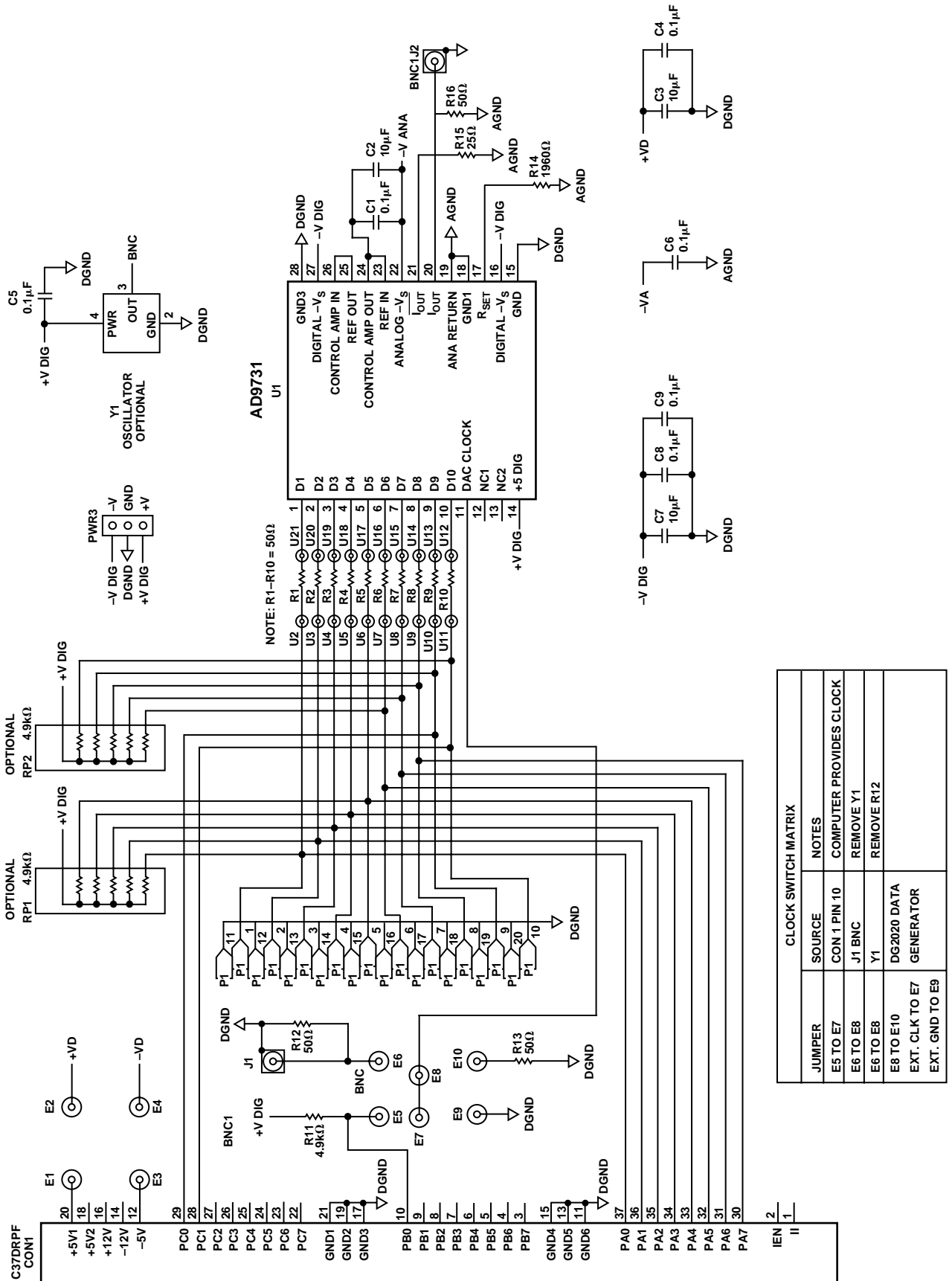
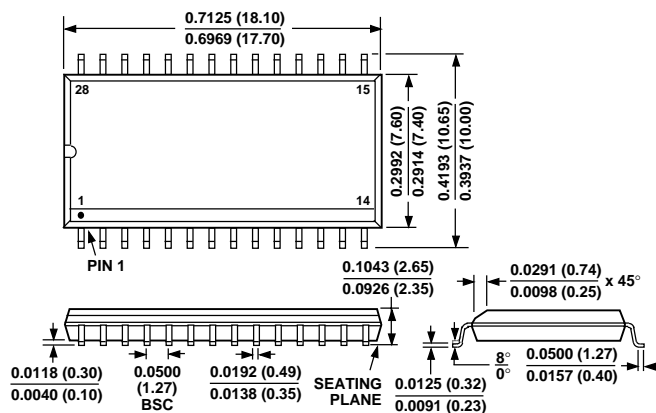

Figure 19. AD9731-PCB Evaluation Board Schematic

OUTLINE DIMENSIONS

Dimensions shown in inches and (mm).

**28-Lead SOIC Wide Body (SOIC)
(R-28)**



**28-Lead Shrink Small Outline (SSOP)
(RS-28)**

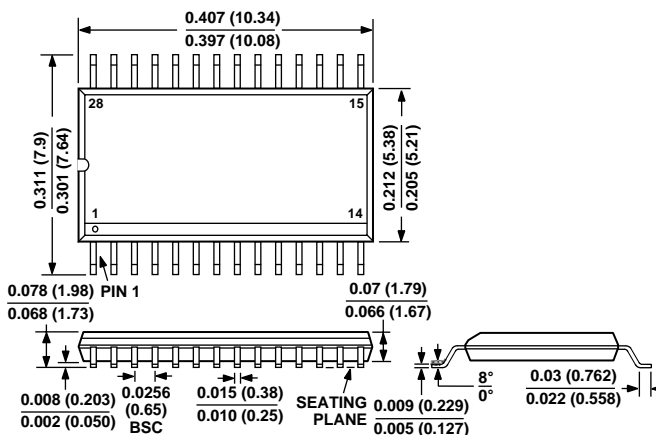



LittleDiode supplies new, hard to find or obsolete electronic components and semiconductors all over the world.

With over two million different components listed you are sure to find the part you need.

Feel free to visit us today at our online store:

LittleDiode.com

Looking forward to providing you with the best possible service.