

### FEATURES

#### Analog Interface

- 140 MSPS Maximum Conversion Rate
- 330 MHz Analog Bandwidth
- 0.5 V to 1.0 V Analog Input Range
- 500 ps p-p PLL Clock Jitter at 140 MSPS
- 3.3 V Power Supply
- Full Sync Processing
- Midscale Clamp
- 4:2:2 Output Format Mode

#### Digital (DVI 1.0 Compatible) Interface

- 112 MHz Operation (1 Pixel/Clock Mode)
- High Skew Tolerance of One Full Input Clock
- Sync Detect for "Hot Plugging"

### APPLICATIONS

- RGB Graphics Processing
- LCD Monitors and Projectors
- Plasma Display Panels
- Scan Converters
- Micro Displays
- Digital TV

### GENERAL DESCRIPTION

The AD9887 offers designers the flexibility of a dual analog and digital interface for flat panel displays (FPDs) on a single chip. Both interfaces are optimized for excellent image quality supporting display resolutions up to SXGA (1280 × 1024 at 75 Hz). Either the analog or the digital interface can be selected by the user.

#### Analog Interface

For ease of design and to minimize cost, the AD9887 is a fully integrated interface solution for FPDs. The AD9887 includes an analog interface with a 140 MHz triple ADC with internal 1.25 V reference, PLL to generate a pixel clock from HSYNC, programmable gain, offset, and clamp control. The user provides only a 3.3 V power supply, analog input, and HSYNC. Three-state CMOS outputs may be powered from 2.5 V to 3.3 V.

The AD9887's on-chip PLL generates a pixel clock from HSYNC. Pixel clock output frequencies range from 12 MHz to 140 MHz. PLL clock jitter is 500 ps p-p typical at 140 MSPS. When a COAST signal is presented, the PLL maintains its output frequency in the absence of HSYNC. A sampling phase adjustment is provided. Data, HSYNC and Clock output phase relationships are maintained. The PLL can be disabled and an external clock input provided as the pixel clock. The AD9887 also offers full sync processing for composite sync and sync-on-green applications.

A clamp signal is generated internally or may be provided by the user through the CLAMP input pin. The analog interface is fully programmable via a 2-wire serial interface.

### REV. 0

Information furnished by Analog Devices is believed to be accurate and reliable. However, no responsibility is assumed by Analog Devices for its use, nor for any infringements of patents or other rights of third parties that may result from its use. No license is granted by implication or otherwise under any patent or patent rights of Analog Devices.

### FUNCTIONAL BLOCK DIAGRAM

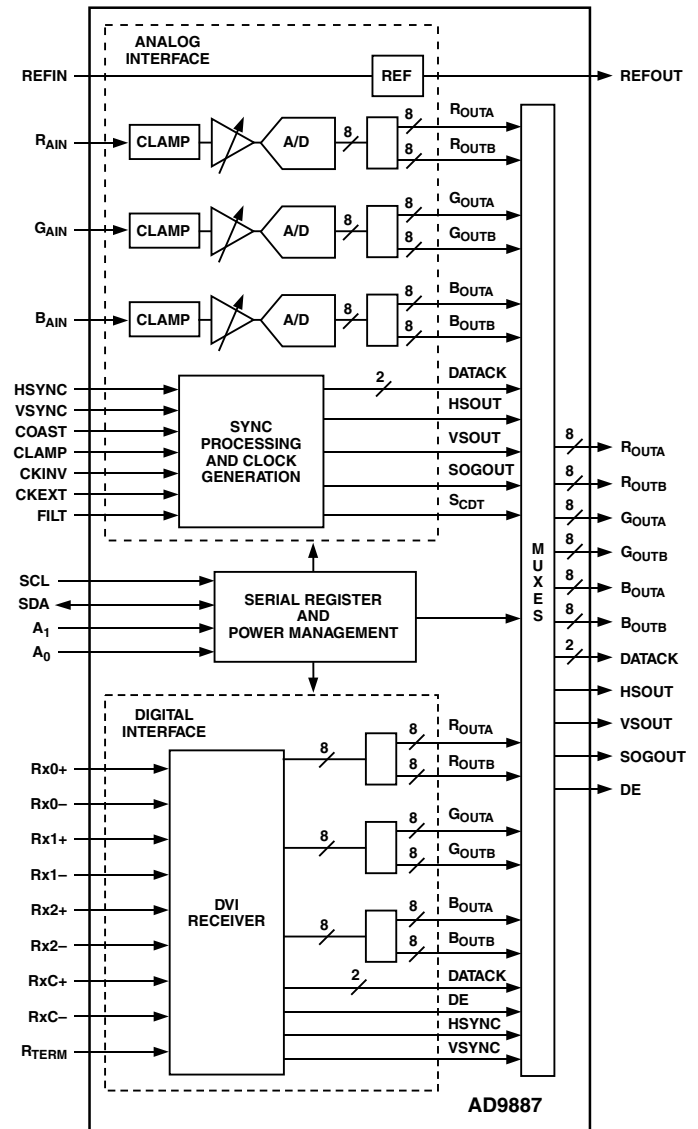

#### Digital Interface

The AD9887 contains a Digital Video Interface (DVI 1.0) compatible receiver. This receiver supports displays ranging from VGA to SXGA (25 MHz to 112 MHz). The receiver operates with true color (24-bit) panels in 1 or 2 pixel(s)/clock mode, and also features an intrapair skew tolerance up to one full clock cycle.

Fabricated in an advanced CMOS process, the AD9887 is provided in a 160-lead MQFP surface mount plastic package and is specified over the 0°C to 70°C temperature range.

# AD9887—SPECIFICATIONS

## ANALOG INTERFACE ( $V_D = 3.3\text{ V}$ , $V_{DD} = 3.3\text{ V}$ , ADC Clock = Maximum Conversion Rate, unless otherwise noted.)

Parameter	Temp	Test Level	AD9887KS-100			AD9887KS-140			Unit
			Min	Typ	Max	Min	Typ	Max	
RESOLUTION			8			8			Bits
DC ACCURACY									
Differential Nonlinearity	25°C	I		±0.5	+1.15/-1.0		±0.5	+1.25/-1.0	LSB
	Full	VI			+1.15/-1.0			+1.25/-1.0	LSB
Integral Nonlinearity	25°C	I		±0.5	±1.40		±0.5	±1.4	LSB
	Full	VI			±1.75			±2.5	LSB
No Missing Codes	Full	VI	Guaranteed			Guaranteed			
ANALOG INPUT									
Input Voltage Range									
Minimum	Full	VI			0.5			0.5	V p-p
Maximum	Full	VI	1.0			1.0			V p-p
Gain Tempco	25°C	V		135			150		ppm/°C
Input Bias Current	25°C	IV			1			1	μA
	Full	IV			1			1	μA
Input Offset Voltage	Full	VI		7	50		7	50	mV
Input Full-Scale Matching	Full	VI			8.0			8.0	% FS
Offset Adjustment Range	Full	VI	44	50	56	44	50	56	% FS
REFERENCE OUTPUT									
Output Voltage	Full	VI	1.20	1.25	1.30	1.20	1.25	1.30	V
Temperature Coefficient	Full	V		±50			±50		ppm/°C
SWITCHING PERFORMANCE <sup>1</sup>									
Maximum Conversion Rate	Full	VI	100			140			MSPS
Minimum Conversion Rate	Full	IV			10			10	MSPS
Clock to Data Skew, $t_{SKEW}$	Full	IV	-0.5		+2.0	-0.5		+2.0	ns
$t_{BUFF}$	Full	VI	4.7			4.7			μs
$t_{STAH}$	Full	VI	4.0			4.0			μs
$t_{DHO}$	Full	VI	0			0			μs
$t_{DAL}$	Full	VI	4.7			4.7			μs
$t_{DAH}$	Full	VI	4.0			4.0			μs
$t_{DSU}$	Full	VI	250			250			ns
$t_{STASU}$	Full	VI	4.7			4.7			μs
$t_{STOSU}$	Full	VI	4.0			4.0			μs
HSYNC Input Frequency	Full	IV	15		110	15		110	kHz
Maximum PLL Clock Rate	Full	VI	100			140			MHz
Minimum PLL Clock Rate	Full	IV			12			12	MHz
PLL Jitter	25°C	IV		400	700 <sup>2</sup>		400	700 <sup>3</sup>	ps p-p
	Full	IV			1000 <sup>2</sup>			1000 <sup>3</sup>	ps p-p
Sampling Phase Tempco	Full	IV		15			15		ps/°C
DIGITAL INPUTS									
Input Voltage, High ( $V_{IH}$ )	Full	VI	2.6			2.6			V
Input Voltage, Low ( $V_{IL}$ )	Full	VI			0.8			0.8	V
Input Current, High ( $I_{IH}$ )	Full	IV			-1.0			-1.0	μA
Input Current, Low ( $I_{IL}$ )	Full	IV			1.0			1.0	μA
Input Capacitance	25°C	V		3			3		pF
DIGITAL OUTPUTS									
Output Voltage, High ( $V_{OH}$ )	Full	VI	2.4			2.4			V
Output Voltage, Low ( $V_{OL}$ )	Full	VI			0.4			0.4	V
Duty Cycle									
DATAACK, $\overline{\text{DATAACK}}$	Full	IV	45	50	55	45	50	55	%
Output Coding				Binary			Binary		

Parameter	Temp	Test Level	AD9887KS-100			AD9887KS-140			Unit
			Min	Typ	Max	Min	Typ	Max	
<b>POWER SUPPLY</b>									
V <sub>D</sub> Supply Voltage	Full	IV	3.0	3.3	3.6	3.0	3.3	3.6	V
V <sub>DD</sub> Supply Voltage	Full	IV	2.2	3.3	3.6	2.2	3.3	3.6	V
P <sub>VD</sub> Supply Voltage	Full	IV	3.0	3.3	3.6	3.0	3.3	3.6	V
I <sub>D</sub> Supply Current (V <sub>D</sub> )	25°C	V		140			155		mA
I <sub>DD</sub> Supply Current (V <sub>DD</sub> ) <sup>4</sup>	25°C	V		34			48		mA
I <sub>PVD</sub> Supply Current (P <sub>VD</sub> )	25°C	V		15			16		mA
Total Supply Current <sup>4</sup>	Full	VI		170	258		215	258	mA
Power-Down Supply Current	Full	VI		18	25		18	25	mA
<b>DYNAMIC PERFORMANCE</b>									
Analog Bandwidth, Full Power	25°C	V		330			330		MHz
Transient Response	25°C	V		2			2		ns
Overvoltage Recovery Time	25°C	V		1.5			1.5		ns
Signal-to-Noise Ratio (SNR) <sup>5</sup>	25°C	V		46			46		dB
(Without Harmonics)	Full	V		45			45		dB
f <sub>IN</sub> = 40.7 MHz									
Crosstalk	Full	V		60			60		dBc
<b>THERMAL CHARACTERISTICS</b>									
θ <sub>JA</sub> Junction-to-Ambient <sup>6</sup>		V		30			30		°C/W
Thermal Resistance									

## NOTES

<sup>1</sup>Drive Strength = 11.<sup>2</sup>VCO Range = 01, Charge Pump Current = 001, PLL Divider = 1693.<sup>3</sup>VCO Range = 10, Charge Pump Current = 110, PLL Divider = 1600.<sup>4</sup>DEMUX = 1, DATAACK and  $\overline{\text{DATAACK}}$  Load = 10 pF, Data Load = 5 pF.<sup>5</sup>Using external pixel clock.<sup>6</sup>Simulated typical performance with package mounted to a 4-layer board.

Specifications subject to change without notice.

# AD9887—SPECIFICATIONS

## DIGITAL INTERFACE ( $V_D = 3.3\text{ V}$ , $V_{DD} = 3\text{ V}$ , Clock = Maximum)

Parameter	Conditions	Test Level	AD9887KS			Unit
			Min	Typ	Max	
RESOLUTION			8			Bits
DC DIGITAL I/O SPECIFICATIONS						
High-Level Input Voltage, ( $V_{IH}$ )		VI	2.6			V
Low-Level Input Voltage, ( $V_{IL}$ )		VI		0.8		V
High-Level Output Voltage, ( $V_{OH}$ )		VI	2.4			V
Low-Level Output Voltage, ( $V_{OL}$ )		VI		0.4		V
Input Clamp Voltage, ( $V_{CINL}$ )	( $I_{CL} = -18\text{ mA}$ )	IV			GND - 0.8	V
Input Clamp Voltage, ( $V_{CIPL}$ )	( $I_{CL} = +18\text{ mA}$ )	IV			$V_{DD} + 0.8$	V
Output Clamp Voltage, ( $V_{CONL}$ )	( $I_{CL} = -18\text{ mA}$ )	IV			GND - 0.8	V
Output Clamp Voltage, ( $V_{COPL}$ )	( $I_{CL} = +18\text{ mA}$ )	IV			$V_{DD} + 0.8$	V
Output Leakage Current, ( $I_{OL}$ )	(High Impedance)	IV	-10		+10	$\mu\text{A}$
DC SPECIFICATIONS						
Output High Drive	Output Drive = High	IV	13			mA
( $I_{OHD}$ ) ( $V_{OUT} = V_{OH}$ )	Output Drive = Med	IV	8			mA
	Output Drive = Low	IV	5			mA
( $I_{OLD}$ ) ( $V_{OUT} = V_{OL}$ )	Output Drive = High	IV	-9			mA
	Output Drive = Med	IV	-7			mA
	Output Drive = Low	IV	-5			mA
	Output Drive = High	IV	25			mA
( $V_{OHC}$ ) ( $V_{OUT} = V_{OH}$ )	Output Drive = Med	IV	12			mA
	Output Drive = Low	IV	8			mA
	Output Drive = High	IV	-25			mA
DATAACK Low Drive	Output Drive = Med	IV	-19			mA
( $V_{OLC}$ ) ( $V_{OUT} = V_{OL}$ )	Output Drive = Low	IV	-8			mA
		IV	75	800		mV
POWER SUPPLY						
$V_D$ Supply Voltage		IV	3.0	3.3	3.6	V
$V_{DD}$ Supply Voltage	Minimum Value for 2 Pixels per Clock Mode	IV	2.2	3.3	3.6	V
$P_{VD}$ Supply Voltage		IV	3.0	3.3	3.6	V
$V_D$ Supply Current (Typical Pattern) <sup>1</sup>		V		274		mA
$V_{DD}$ Supply Current (Typical Pattern) <sup>1, 4</sup>		V		38		mA
$P_{VD}$ Supply Current (Typical Pattern) <sup>1</sup>		V		21		mA
Total Supply Current (Typical Pattern) <sup>1, 4</sup>		VI		362		mA
$V_D$ Supply Current (Worst-Case Pattern) <sup>2</sup>		V		280		mA
$V_{DD}$ Supply Current (Worst-Case Pattern) <sup>2, 4</sup>		V		75		mA
$P_{VD}$ Supply Current (Worst-Case Pattern) <sup>2</sup>		V		21		mA
Total Supply Current (Worst-Case Pattern) <sup>2, 4</sup>		VI		400		mA
Power-Down Supply Current ( $I_{PD}$ )		VI		13	25	mA
AC SPECIFICATIONS						
Intrapair (+ to -) Differential Input Skew ( $T_{DPS}$ )		IV			360	ps
Channel-to-Channel Differential Input Skew ( $T_{CCS}$ )		IV			1.0	Clock Period
Low-to-High Transition Time for Data and Controls ( $D_{LHT}$ )	Output Drive = High; $C_L = 10\text{ pF}$	IV			2.0	ns
	Output Drive = Med; $C_L = 7\text{ pF}$	IV			3.0	ns
	Output Drive = Low; $C_L = 5\text{ pF}$	IV			3.4	ns
Low-to-High Transition Time for DATAACK ( $D_{LHT}$ )	Output Drive = High; $C_L = 10\text{ pF}$	IV			1.3	ns
	Output Drive = Med; $C_L = 7\text{ pF}$	IV			1.9	ns
	Output Drive = Low; $C_L = 5\text{ pF}$	IV			2.5	ns
	Output Drive = High; $C_L = 10\text{ pF}$	IV			2.7	ns
High-to-Low Transition Time for Data and Controls ( $D_{HLT}$ )	Output Drive = Med; $C_L = 7\text{ pF}$	IV			3.0	ns
	Output Drive = Low; $C_L = 5\text{ pF}$	IV			3.3	ns

Parameter	Conditions	Test Level	AD9887KS			Unit
			Min	Typ	Max	
AC SPECIFICATIONS (continued)						
High-to-Low Transition Time for DATAACK ( $D_{HLT}$ )	Output Drive = High; $C_L = 10$ pF	IV			1.4	ns
	Output Drive = Med; $C_L = 7$ pF	IV			1.7	ns
	Output Drive = Low; $C_L = 5$ pF	IV			2.1	ns
Clock to Data Skew, $t_{SKEW}$ Duty Cycle, $t_{DCYCLE}$		IV	-0.5		+2.0	ns
		IV	45		55	% of Period High
DATAACK Frequency ( $F_{CIP}$ ) (1 Pixel/Clock)		VI	20		112	MHz
DATAACK Frequency ( $F_{CIP}$ ) (2 Pixels/Clock)		IV	10		56	MHz

## NOTES

<sup>1</sup>The typical pattern contains a gray scale area, Output Drive = High.

<sup>2</sup>The worst-case pattern contains a black and white checkerboard pattern, Output Drive = High.

<sup>3</sup>The setup and hold times with respect to the DATAACK rising edge are the same as the falling edge.

<sup>4</sup>1 Pixel/clock mode, DATAACK and  $\overline{\text{DATAACK}}$  Load = 10 pF, Data Load = 5 pF.

## ABSOLUTE MAXIMUM RATINGS\*

$V_D$ .....	3.6 V
$V_{DD}$ .....	3.6 V
Analog Inputs .....	$V_D$ to 0.0 V
VREF IN .....	$V_D$ to 0.0 V
Digital Inputs .....	5 V to 0.0 V
Digital Output Current .....	20 mA
Operating Temperature .....	-25°C to +85°C
Storage Temperature .....	-65°C to +150°C
Maximum Junction Temperature .....	150°C
Maximum Case Temperature .....	150°C

\*Stresses above those listed under Absolute Maximum Ratings may cause permanent damage to the device. This is a stress rating only; functional operation of the device at these or any other conditions outside of those indicated in the operation sections of this specification is not implied. Exposure to absolute maximum ratings for extended periods may affect device reliability.

## EXPLANATION OF TEST LEVELS

Test Level	Explanation
I	100% production tested.
II	100% production tested at 25°C and sample tested at specified temperatures.
III	Sample tested only.
IV	Parameter is guaranteed by design and characterization testing.
V	Parameter is a typical value only.
VI	100% production tested at 25°C; guaranteed by design and characterization testing.

## ORDERING GUIDE

Model	Temperature Range	Package Description	Package Option
AD9887KS-140	0°C to 70°C	Plastic Quad Flatpack	S-160
AD9887KS-100	0°C to 70°C	Plastic Quad Flatpack	S-160
AD9887/PCB	25°C	Evaluation Board	

## CAUTION

ESD (electrostatic discharge) sensitive device. Electrostatic charges as high as 4000 V readily accumulate on the human body and test equipment and can discharge without detection. Although the AD9887 features proprietary ESD protection circuitry, permanent damage may occur on devices subjected to high-energy electrostatic discharges. Therefore, proper ESD precautions are recommended to avoid performance degradation or loss of functionality.



PIN CONFIGURATION

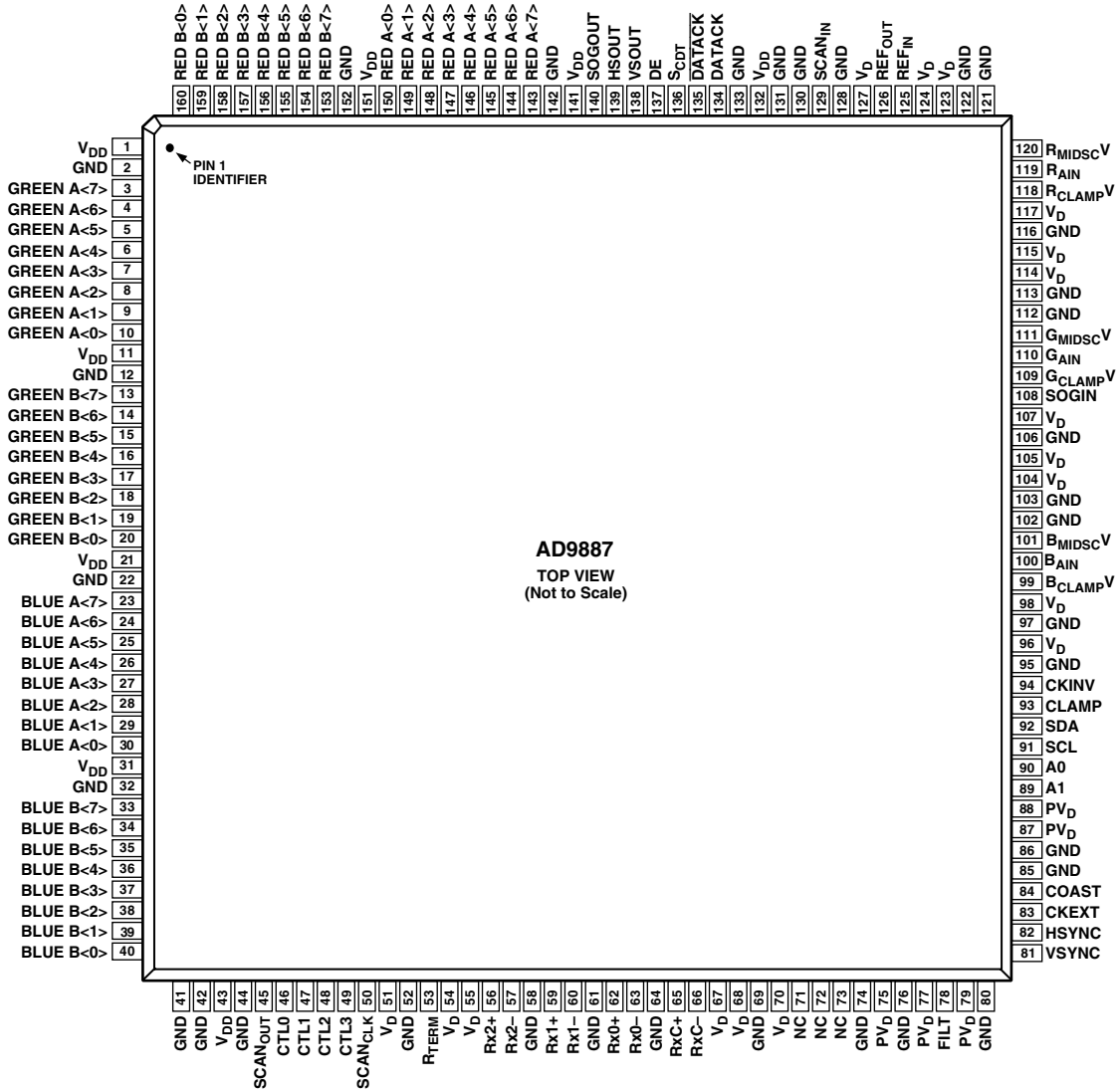

NC = NO CONNECT

Table I. Complete Pinout List

Pin Type	Pin Name	Function	Value	Pin Number	Interface
Analog Video Inputs	R <sub>AIN</sub>	Analog Input for Converter R	0.0 V to 1.0 V	119	Analog
	G <sub>AIN</sub>	Analog Input for Converter G	0.0 V to 1.0 V	110	Analog
	B <sub>AIN</sub>	Analog Input for Converter B	0.0 V to 1.0 V	100	Analog
External Sync/Clock Inputs	HSYNC	Horizontal SYNC Input	3.3 V CMOS	82	Analog
	VSYNC	Vertical SYNC Input	3.3 V CMOS	81	Analog
	SOGIN	Input for Sync-on-Green	0.0 V to 1.0 V	108	Analog
	CLAMP	Clamp Input (External CLAMP Signal)	3.3 V CMOS	93	Analog
	COAST	PLL COAST Signal Input	3.3 V CMOS	84	Analog
	CKEXT	External Pixel Clock Input (to Bypass the PLL) to V <sub>DD</sub> or Ground	3.3 V CMOS	83	Analog
Sync Outputs	CKINV	ADC Sampling Clock Invert	3.3 V CMOS	94	Analog
	HSOUT	HSYNC Output Clock (Phase-Aligned with DATAACK)	3.3 V CMOS	139	Both
Voltage Reference	VSOUT	VSYNC Output Clock (Phase-Aligned with DATAACK)	3.3 V CMOS	138	Both
	SOGOUT	Sync on Green Slicer Output	3.3 V CMOS	140	Analog
	REFOUT	Internal Reference Output (Bypass with 0.1 μF to Ground)	1.25 V	126	Analog
Clamp Voltages	REFIN	Reference Input (1.25 V ± 10%)	1.25 V ± 10%	125	Analog
	R <sub>MIDSC</sub> V	Red Channel Midscale Clamp Voltage Output	0.0 V to 0.75 V	120	Analog
R <sub>CLAMP</sub> V	Red Channel Midscale Clamp Voltage Input	118		Analog	
PLL Filter	G <sub>MIDSC</sub> V	Green Channel Midscale Clamp Voltage Output	0.0 V to 0.75 V	111	Analog
	G <sub>CLAMP</sub> V	Green Channel Midscale Clamp Voltage Input		109	Analog
	B <sub>MIDSC</sub> V	Blue Channel Midscale Clamp Voltage Output	0.0 V to 0.75 V	101	Analog
	B <sub>CLAMP</sub> V	Blue Channel Midscale Clamp Voltage Input		99	Analog
Power Supply	FILT	Connection for External Filter Components for Internal PLL		78	Analog
Serial Port (2-Wire Serial Interface)	V <sub>D</sub>	Analog Power Supply	3.3 V ± 10%		Both
	V <sub>DD</sub>	Output Power Supply	3.3 V ± 10%		Both
	PV <sub>D</sub>	PLL Power Supply	3.3 V ± 10%		Both
	GND	Ground	0 V		Both
Data Outputs	SDA	Serial Port Data I/O	3.3 V CMOS	92	Both
	SCL	Serial Port Data Clock (100 kHz Max)	3.3 V CMOS	91	Both
	A0	Serial Port Address Input 1	3.3 V CMOS	90	Both
	A1	Serial Port Address Input 2	3.3 V CMOS	89	Both
Data Clock Outputs	Red B[7:0]	Port B/Odd Outputs of Converter “Red,” Bit 7 Is the MSB	3.3 V CMOS	153–160	Both
	Green B[7:0]	Port B/Odd Outputs of Converter “Green,” Bit 7 Is the MSB	3.3 V CMOS	13–20	Both
	Blue B[7:0]	Port B/Odd Outputs of Converter “Blue,” Bit 7 Is the MSB	3.3 V CMOS	33–40	Both
	Red A[7:0]	Port A/Even Outputs of Converter “Red,” Bit 7 Is the MSB	3.3 V CMOS	143–150	Both
	Green A[7:0]	Port A/Even Outputs of Converter “Green,” Bit 7 Is the MSB	3.3 V CMOS	3–10	Both
	Blue A[7:0]	Port A/Even Outputs of Converter “Blue,” Bit 7 Is the MSB	3.3 V CMOS	23–30	Both
Sync Detect	DATAACK	Data Output Clock for the Analog and Digital Interface	3.3 V CMOS	134	Both
	<u>DATAACK</u>	Data Output Clock Complement for the Analog Interface Only	3.3 V CMOS	135	Both
Scan Function	S <sub>CDT</sub>	Sync Detect Output	3.3 V CMOS	136	Both
No Connect	SCAN <sub>IN</sub>	Input for SCAN Function	3.3 V CMOS	129	Both
	SCAN <sub>OUT</sub>	Output for SCAN Function	3.3 V CMOS	45	Both
	SCAN <sub>CLK</sub>	Clock for SCAN Function	3.3 V CMOS	50	Both
Digital Video Data Inputs	NC	These Pins Should be Left Unconnected		71–73	Both
	R <sub>x0+</sub>	Digital Input Channel 0 True		62	Digital
	R <sub>x0-</sub>	Digital Input Channel 0 Complement		63	Digital
	R <sub>x1+</sub>	Digital Input Channel 1 True		59	Digital
	R <sub>x1-</sub>	Digital Input Channel 1 Complement		60	Digital
	R <sub>x2+</sub>	Digital Input Channel 2 True		56	Digital
Digital Video Clock Inputs	R <sub>x2-</sub>	Digital Input Channel 2 Complement		57	Digital
	R <sub>xc+</sub>	Digital Data Clock True		65	Digital
Data Enable	R <sub>xc-</sub>	Digital Data Clock Complement		66	Digital
Control Bits	DE	Data Enable	3.3 V CMOS	137	Digital
R <sub>TERM</sub>	CTL[0:3]	Decoded Control Bits	3.3 V CMOS	46–49	Digital
	R <sub>TERM</sub>	Sets Internal Termination Resistance		53	Digital

# AD9887

## DESCRIPTIONS OF PINS SHARED BETWEEN ANALOG AND DIGITAL INTERFACES

**HSOUT** Horizontal Sync Output  
A reconstructed and phase-aligned version of the video HSYNC. The polarity of this output can be controlled via a serial bus bit. In analog interface mode the placement and duration are variable. In digital interface mode the placement and duration are set by the graphics transmitter.

**VSOUT** Vertical Sync Output  
The separated VSYNC from a composite signal or a direct pass through of the VSYNC input. The polarity of this output can be controlled via a serial bus bit. The placement and duration in all modes is set by the graphics transmitter.

### Serial Port (2-Wire)

**SDA** Serial Port Data I/O  
**SCL** Serial Port Data Clock  
**A0** Serial Port Address Input 1  
**A1** Serial Port Address Input 2  
For a full description of the 2-wire serial register and how it works, refer to the Control Register section.

### Data Outputs

**RED A** Data Output, Red Channel, Port A/Even  
**RED B** Data Output, Red Channel, Port B/Odd  
**GREEN A** Data Output, Green Channel, Port A/Even  
**GREEN B** Data Output, Green Channel, Port B/Odd  
**BLUE A** Data Output, Blue Channel, Port A/Even  
**BLUE B** Data Output, Blue Channel, Port B/Odd  
The main data outputs. Bit 7 is the MSB. These outputs are shared between the two interfaces and behave according to which interface is active. Refer to the sections on the two interfaces for more information on how these outputs behave.

### Data Clock Outputs

**DATA $\overline{\text{CK}}$**  Data Output Clock  
**DATA $\overline{\text{CK}}$**  Data Output Clock Complement

Just like the data outputs, the data clock outputs are shared between the two interfaces. They also behave differently depending on which interface is active. Refer to the sections on the two interfaces to determine how these pins behave.

### Various

**S $\overline{\text{CDT}}$**  Chip Active/Inactive Detect Output  
The logic for the S $\overline{\text{CDT}}$  pin is [analog interface HSYNC detection] OR [digital interface DE detection]. So, the S $\overline{\text{CDT}}$  pin will switch to logic LOW under two conditions, when neither interface is active *or* when the chip is in full chip power-down mode. The data outputs are automatically three-stated when S $\overline{\text{CDT}}$  is LOW. This pin can be read by a controller in order to determine periods of inactivity.

### SCAN Function

**SCAN $\overline{\text{IN}}$**  Data Input for SCAN Function  
Data can be loaded serially into the 48-bit SCAN register through this pin, clocking it in with the SCAN $\overline{\text{CLK}}$  pin. It then comes out of the 48 data outputs in parallel. This function is useful for loading known data into a graphics controller chip for testing purposes.  
**SCAN $\overline{\text{OUT}}$**  Data Output for SCAN Function  
The data in the 48-bit SCAN register can be read through this pin. Data is read on a FIFO basis and is clocked via the SCAN $\overline{\text{CLK}}$  pin.  
**SCAN $\overline{\text{CLK}}$**  Data Clock for SCAN Function  
This pin clocks the data through the SCAN register. It controls both data input and data output.

Table II. Analog Interface Pin List

Pin Type	Pin Name	Function	Value	Pin No.
Analog Video Inputs	R <sub>AIN</sub>	Analog Input for Converter R	0.0 V to 1.0 V	119
	G <sub>AIN</sub>	Analog Input for Converter G	0.0 V to 1.0 V	110
	B <sub>AIN</sub>	Analog Input for Converter B	0.0 V to 1.0 V	100
External	HSYNC	Horizontal SYNC Input	3.3 V CMOS	82
	VSYNC	Vertical SYNC Input	3.3 V CMOS	81
Sync/Clock Inputs	SOGIN	Sync-on-Green Input	0.0 V to 1.0 V	108
	CLAMP	Clamp Input (External CLAMP Signal)	3.3 V CMOS	93
	COAST	PLL COAST Signal Input	3.3 V CMOS	84
	CKEXT	External Pixel Clock Input (to Bypass Internal PLL) or 10 kΩ to V <sub>DD</sub>	3.3 V CMOS	83
Sync Outputs	CKINV	ADC Sampling Clock Invert	3.3 V CMOS	94
	HSOUT	HSYNC Output (Phase-Aligned with DATA <sub>CK</sub> and $\overline{\text{DATA}}_{\text{CK}}$ )	3.3 V CMOS	139
	VSOUT	VSYNC Output (Asynchronous)	3.3 V CMOS	138
	SOGOUT	Sync-on-Green Slicer Output or Raw HSYNC Output	3.3 V CMOS	140
Voltage Reference	REFOUT	Internal Reference Output (bypass with 0.1 μF to ground)	1.25 V	126
	REFIN	Reference Input (1.25 V ± 10%)	1.25 V ± 10%	125
Clamp Voltages	R <sub>MIDSC</sub> V	Voltage output equal to the RED converter midscale voltage.	0.5 V ± 50%	120
	R <sub>CLAMP</sub> V	During midscale clamping, the RED Input is clamped to this pin.	0.0 V to 0.75 V	118
	G <sub>MIDSC</sub> V	Voltage output equal to the GREEN converter midscale voltage.	0.5 V ± 50%	111
	G <sub>CLAMP</sub> V	During midscale clamping, the GREEN Input is clamped to this pin.	0.0 V to 0.75 V	109
	B <sub>MIDSC</sub> V	Voltage output equal to the BLUE converter midscale voltage.	0.5 V ± 50%	101
	B <sub>CLAMP</sub> V	During midscale clamping, the BLUE Input is clamped to this pin.	0.0 V to 0.75 V	99
PLL Filter	FILT	Connection for External Filter Components for Internal PLL		78
Power Supply	V <sub>D</sub>	Main Power Supply	3.3 V ± 5%	
	PV <sub>D</sub>	PLL Power Supply (Nominally 3.3 V)	3.3 V ± 5%	
	V <sub>DD</sub>	Output Power Supply	3.3 V or 2.5 V ± 5%	
	GND	Ground	0 V	

**PIN FUNCTION DETAILS (ANALOG INTERFACE)****Inputs**

R<sub>AIN</sub> Analog Input for RED Channel

G<sub>AIN</sub> Analog Input for GREEN Channel

B<sub>AIN</sub> Analog Input for BLUE Channel

High-impedance inputs that accept the RED, GREEN, and BLUE channel graphics signals, respectively. For RGB, the three channels are identical and can be used for any colors, but colors are assigned for convenient reference. For proper 4:2:2 formatting in a YUV application, the Y channel must be connected to the G<sub>AIN</sub> input, U must be connected to the B<sub>AIN</sub> input, and V must be connected to the R<sub>AIN</sub> input.

They accommodate input signals ranging from 0.5 V to 1.0 V full scale. Signals should be ac-coupled to these pins to support clamp operation.

HSYNC Horizontal Sync Input

This input receives a logic signal that establishes the horizontal timing reference and provides the frequency reference for pixel clock generation.

The logic sense of this pin is controlled by serial register 0Fh Bit 7 (HSYNC Polarity). Only the leading edge of HSYNC is active, the trailing edge is ignored. When HSYNC

Polarity = 0, the falling edge of HSYNC is used. When HSYNC Polarity = 1, the rising edge is active.

The input includes a Schmitt trigger for noise immunity, with a nominal input threshold of 1.5 V.

Electrostatic Discharge (ESD) protection diodes will conduct heavily if this pin is driven more than 0.5 V above the maximum tolerance voltage (3.3 V), or more than 0.5 V below ground.

VSYNC Vertical Sync Input

This is the input for vertical sync.

SOGIN Sync-on-Green Input

This input is provided to assist with processing signals with embedded sync, typically on the GREEN channel. The pin is connected to a high-speed comparator with an internally generated threshold, which is set to 0.15 V above the negative peak of the input signal.

When connected to an ac-coupled graphics signal with embedded sync, it will produce a noninverting digital output on SOGOUT.

When not used, this input should be left unconnected. For more details on this function and how it should be configured, refer to the Sync-on-Green section.

# AD9887

CLAMP	<p>External Clamp Input (Optional)</p> <p>This logic input may be used to define the time during which the input signal is clamped to the reference dc level, (ground for RGB or midscale for YUV). It should be exercised when the reference dc level is known to be present on the analog input channels, typically during the back porch of the graphics signal. The CLAMP pin is enabled by setting control bit EXTCLMP to 1, (the default power-up is 0). When disabled, this pin is ignored and the clamp timing is determined internally by counting a delay and duration from the trailing edge of the HSYNC input. The logic sense of this pin is controlled by CLAMPOL. When not used, this pin must be grounded and EXTCLMP programmed to 0.</p>	<p>This pin should be exercised only during blanking intervals (typically vertical blanking) as it may produce several samples of corrupted data during the phase shift.</p> <p>CKINV should be grounded when not used.</p>
COAST	<p>Clock Generator Coast Input (Optional)</p> <p>This input may be used to cause the pixel clock generator to stop synchronizing with HSYNC and continue producing a clock at its current frequency and phase. This is useful when processing signals from sources that fail to produce horizontal sync pulses when in the vertical interval. The COAST signal is generally <i>not</i> required for PC-generated signals. Applications requiring COAST can do so through the internal COAST found in the SYNC processing engine.</p> <p>The logic sense of this pin is controlled by COAST Polarity.</p> <p>When not used, this pin may be grounded and COAST Polarity programmed to 1, or tied HIGH and COAST Polarity programmed to 0. COAST Polarity defaults to 1 at power-up.</p>	<p>Each channel has two ports. When the part is operated in single-channel mode (DEMUX = 0), all data are presented to Port A, and Port B is placed in a high-impedance state.</p> <p>Programming DEMUX to 1 established dual-channel mode, wherein alternate pixels are presented to Port A and Port B of each channel. These will appear simultaneously, two pixels presented at the time of every second input pixel, when PAR is set to 1 (parallel mode). When PAR = 0, pixel data appear alternately on the two ports, one new sample with each incoming pixel (interleaved mode).</p> <p>In dual channel mode, the first pixel after HSYNC is routed to Port A. The second pixel goes to Port B, the third to A, etc.</p> <p>The delay from pixel sampling time to output is fixed. When the sampling time is changed by adjusting the PHASE register, the output timing is shifted as well. The DATAACK, <math>\overline{\text{DATAACK}}</math>, and HSOUT outputs are also moved, so the timing relationship among the signals is maintained.</p>
CKEXT	<p>External Clock Input (Optional)</p> <p>This pin may be used to provide an external clock to the AD9887, in place of the clock internally generated from HSYNC.</p> <p>It is enabled by programming EXTCLK to 1. When an external clock is used, all other internal functions operate normally. When unused, this pin should be tied to V<sub>DD</sub> or to GROUND, and EXTCLK programmed to 0. The clock phase adjustment still operates when an external clock source is used.</p>	<p>These are the main data outputs. Bit 7 is the MSB.</p>
CKINV	<p>Sampling Clock Inversion (Optional)</p> <p>This pin may be used to invert the pixel sampling clock, which has the effect of shifting the sampling phase 180°. This is in support of Alternate Pixel Sampling mode, wherein higher-frequency input signals (up to 280 Mpps) may be captured by first sampling the odd pixels, then capturing the even pixels on the subsequent frame.</p>	<p>When the AD9887 is operated in single-channel mode, the output frequency is equal to the pixel sampling frequency. When operating in dual channel mode, the clock frequency is one-half the pixel frequency.</p> <p>When the sampling time is changed by adjusting the PHASE register, the output timing is shifted as well. The Data, DATAACK, <math>\overline{\text{DATAACK}}</math>, and HSOUT outputs are all moved, so the timing relationship among the signals is maintained.</p>

## Outputs

D<sub>RA</sub>7-0

Data Output, Red Channel, Port A

D<sub>RB</sub>7-0

Data Output, Red Channel, Port B

D<sub>GA</sub>7-0

Data Output, Green Channel, Port A

D<sub>GB</sub>7-0

Data Output, Green Channel, Port B

D<sub>BA</sub>7-0

Data Output, Blue Channel, Port A

D<sub>BB</sub>7-0

Data Output, Blue Channel, Port B

DATAACK

Data Output Clock

$\overline{\text{DATAACK}}$

Data Output Clock Complement

Differential data clock output signals to be used to strobe the output data and HSOUT into external logic.

They are produced by the internal clock generator and are synchronous with the internal pixel sampling clock.

	Either or both signals may be used, depending on the timing mode and interface design employed.		
HSOUT	<p>Horizontal Sync Output</p> <p>A reconstructed and phase-aligned version of the Hsync input. Both the polarity and duration of this output can be programmed via serial bus registers.</p> <p>By maintaining alignment with <math>\overline{\text{DATAACK}}</math>, <math>\overline{\text{DATAACK}}</math>, and Data, data timing with respect to horizontal sync can always be determined.</p>		
SOGOUT	<p>Sync-On-Green Slicer Output</p> <p>This pin can be programmed to output either the output from the Sync-On-Green slicer comparator or an unprocessed but delayed version of the HSYNC input. See the Sync Block Diagram to view how this pin is connected.</p> <p>(Note: The output from this pin is the sliced SOG, without additional processing from the AD9887.)</p>		
<b>Analog Interface</b>			
REFOUT	<p>Internal Reference Output</p> <p>Output from the internal 1.25 V bandgap reference. This output is intended to drive relatively light loads. It can drive the AD9887 Reference Input directly, but should be externally buffered if it is used to drive other loads as well.</p> <p>The absolute accuracy of this output is <math>\pm 4\%</math>, and the temperature coefficient is <math>\pm 50</math> ppm, which is adequate for most AD9887 applications. If higher accuracy is required, an external reference may be employed instead.</p> <p>If an external reference is used, connect this pin to ground through a 0.1 <math>\mu\text{F}</math> capacitor.</p>		
REFIN	<p>Reference Input</p> <p>The reference input accepts the master reference voltage for all AD9887 internal circuitry (1.25 V <math>\pm 10\%</math>). It may be driven directly by the REFOUT pin. Its high impedance presents a very light load to the reference source.</p> <p>This pin should always be bypassed to Ground with a 0.1 <math>\mu\text{F}</math> capacitor.</p>		
FILT	<p>External Filter Connection</p> <p>For proper operation, the pixel clock generator PLL requires an external filter. Connect the filter shown Figure 7 to this pin. For optimal performance, minimize noise and parasitics on this node.</p>		
		<b>Power Supply</b>	
		$V_D$	<p>Main Power Supply</p> <p>These pins supply power to the main elements of the circuit. It should be filtered to be as quiet as possible.</p>
		$V_{DD}$	<p>Digital Output Power Supply</p> <p>These supply pins are identified separately from the <math>V_D</math> pins so special care can be taken to minimize output noise transferred into the sensitive analog circuitry.</p> <p>If the AD9887 is interfacing with lower-voltage logic, <math>V_{DD}</math> may be connected to a lower supply voltage (as low as 2.2 V) for compatibility.</p>
		$PV_D$	<p>Clock Generator Power Supply</p> <p>The most sensitive portion of the AD9887 is the clock generation circuitry. These pins provide power to the clock PLL and help the user design for optimal performance. The designer should provide noise-free power to these pins.</p>
		GND	<p>Ground</p> <p>The ground return for all circuitry on chip. It is recommended that the application circuit board have a single, solid ground plane.</p>
			<b>THEORY OF OPERATION (INTERFACE DETECTION)</b>
			<b>Active Interface Detection and Selection</b>
			The AD9887 includes circuitry to detect whether or not an interface is active.
			For detecting the <i>analog</i> interface, the circuitry monitors the presence of HSYNC, VSYNC, and Sync-on-Green. The result of the detection circuitry can be read from the 2-wire serial interface bus at address 11H Bits 7, 6, and 5 respectively. If one of these sync signals disappears, the maximum time it takes for the circuitry to detect it is 100 ms.
			There are two stages for detecting the <i>digital</i> interface. The first stage searches for the presence of the digital interface clock. The circuitry for detecting the digital interface clock is active even when the digital interface is powered down. The result of this detection stage can be read from the 2-wire serial interface bus at address 11H Bit 4. If the clock disappears, the maximum time it takes for the circuitry to detect it is 100 ms. The second stage attempts to detect DE on the digital interface. Detection is accomplished when 32 DEs have been counted. DE can only be detected when the digital interface is powered up, so it is not always active. The DE detection circuitry is one of the logic inputs used to set the SyncDT output pin (Pin 136). The logic for the SyncDT pin is [DE detect] OR [HSYNC detect].
			There is an override for the automatic interface selection. It is the AIO bit (Active Interface Override). When the AIO bit is set to Logic 0, the automatic circuitry will be used. When the AIO bit is set to Logic 1, the AIS bit will be used to determine the active interface rather than the automatic circuitry.

# AD9887

## Power Management

The AD9887 is a dual interface device with shared outputs. Only one interface can be used at a time. For this reason, the chip automatically powers down the unused interface. When the analog interface is being used, most of the digital interface circuitry is powered down and vice-versa. This helps to minimize the AD9887 total power dissipation. In addition, if neither interface has activity on it, the chip powers down both interfaces.

The AD9887 uses the activity detect circuits, the active interface bits in the serial registers, the active interface override bits,

and the power-down bit to determine the correct power state. In a given power mode not all circuitry in the inactive interface is powered down completely. When the digital interface is active, the bandgap reference and HSYNC detect circuitry is not powered down. When the analog interface is active, the digital interface clock detect circuit is not powered down. Table IV summarizes how the AD9887 determines which power mode to be in and what circuitry is powered on/off in each of these modes. The power-down command has priority, followed by the active interface override, and then the automatic circuitry.

**Table III. Interface Selection Controls**

AIO	Analog Interface Detect	Digital Interface Detect	AIS	Active Interface	Description
1	X	X	0	Analog	Force the analog interface active.
0	0	0	1	Digital	Force the digital interface active.
	0	0	X	None	Neither interface was detected. Both interfaces are powered down and the SyncDT pin gets set to Logic 0.
	0	1	X	Digital	The digital interface was detected. Power down the analog interface.
	1	0	X	Analog	The analog interface was detected. Power down the digital interface.
	1	0	X	Analog	Both interfaces were detected. The analog interface has priority.
			1	Digital	Both interfaces were detected. The digital interface has priority.

**Table IV. Power-Down Mode Descriptions**

Mode	Inputs					Powered On or Comments
	Power-Down <sup>1</sup>	Analog Interface Detect <sup>2</sup>	Digital Interface Detect <sup>3</sup>	Active Interface Override	Active Interface Select	
Soft Power-Down (Seek Mode)	1	0	0	0	X	Serial Bus, Digital Interface Clock Detect, Analog Interface Activity Detect, SOG, Bandgap Reference
Digital Interface On	1	0	1	0	X	Serial Bus, Digital Interface, Analog Interface Activity Detect, SOG, Outputs, Bandgap Reference
Analog Interface On	1	1	0	0	X	Serial Bus, Analog Interface, Digital Interface Clock Detect, SOG, Outputs, Bandgap Reference
Serial Bus Arbitrated Interface	1	1	1	0	0	Same as Analog Interface On Mode
Serial Bus Arbitrated Interface	1	1	1	0	1	Same as Digital Interface On Mode
Override to Analog Interface	1	X	X	1	0	Same as Analog Interface On Mode
Override to Digital Interface	1	X	X	1	1	Same as Digital Interface On Mode
Absolute Power-Down	0	X	X	X	X	Serial Bus

### NOTES

<sup>1</sup>Power-down is controlled via bit 0 in serial bus Register 12h.

<sup>2</sup>Analog Interface Detect is determined by OR-ing Bits 7, 6, and 5 in serial bus Register 11h.

<sup>3</sup>Digital Interface Detect is determined by Bit 4 in serial bus Register 11h.

## THEORY OF OPERATION AND DESIGN GUIDE (ANALOG INTERFACE)

### General Description

The AD9887 is a fully integrated solution for capturing analog RGB signals and digitizing them for display on flat panel monitors or projectors. The device is ideal for implementing a computer interface in HDTV monitors or as the front end to high-performance video scan converters.

Implemented in a high-performance CMOS process, the interface can capture signals with pixel rates of up to 140 MHz and, with an Alternate Pixel Sampling mode, up to 280 MHz.

The AD9887 includes all necessary input buffering, signal dc restoration (clamping), offset and gain (brightness and contrast) adjustment, pixel clock generation, sampling phase control, and output data formatting. All controls are programmable via a 2-wire serial interface. Full integration of these sensitive analog functions makes system design straightforward and less sensitive to the physical and electrical environment.

With a typical power dissipation of less than 725 mW and an operating temperature range of 0°C to 70°C, the device requires no special environmental considerations.

### Input Signal Handling

The AD9887 has three high-impedance analog input pins for the Red, Green, and Blue channels. They will accommodate signals ranging from 0.5 V to 1.0 V p-p.

Signals are typically brought onto the interface board via a DVI-I connector, a 15-lead D connector, or BNC connectors. The AD9887 should be located as close as practical to the input connector. Signals should be routed via matched-impedance traces (normally 75 Ω) to the IC input pins.

At that point the signal should be resistively terminated (75 Ω to the signal ground return) and capacitively coupled to the AD9887 inputs through 47 nF capacitors. These capacitors form part of the dc restoration circuit.

In an ideal world of perfectly matched impedances, the best performance can be obtained with the widest possible signal bandwidth. The wide bandwidth inputs of the AD9887 (330 MHz) can track the input signal continuously as it moves from one pixel level to the next, and digitize the pixel during a long, flat pixel time. In many systems, however, there are mismatches, reflections, and noise, which can result in excessive ringing and distortion of the input waveform. This makes it more difficult to establish a sampling phase that provides good image quality. It has been shown that a small inductor in series with the input is effective in rolling off the input bandwidth slightly, and providing a high quality signal over a wider range of conditions. Using a Fair-Rite #2508051217Z0 High-Speed Signal Chip Bead inductor in the circuit of Figure 1 gives good results in most applications.

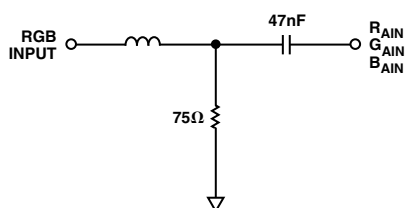

Figure 1. Analog Input Interface Circuit

### HSYNC, VSYNC Inputs

The AD9887 receives a horizontal sync signal and uses it to generate the pixel clock and clamp timing. It is possible to operate the AD9887 without applying HSYNC (using an external clock, external clamp) but a number of features of the chip will be unavailable, so it is recommended that HSYNC be provided. This can be either a sync signal directly from the graphics source, or a preprocessed TTL or CMOS level signal.

The HSYNC input includes a Schmitt trigger buffer and is capable of handling signals with long rise times, with superior noise immunity. In typical PC-based graphic systems, the sync signals are simply TTL-level drivers feeding unshielded wires in the monitor cable. As such, no termination is required or desired.

When the VSYNC input is selected as the source for  $V_{\text{SYNC}}$ , it is used for COAST generation and is passed through to the VSOUT pin.

### Serial Control Port

The serial control port is designed for 3.3 V logic. If there are 5 V drivers on the bus, these pins should be protected with 150 Ω series resistors placed between the pull-up resistors and the input pins.

### Output Signal Handling

The digital outputs are designed and specified to operate from a 3.3 V power supply ( $V_{\text{DD}}$ ). They can also work with a  $V_{\text{DD}}$  as low as 2.5 V for compatibility with other 2.5 V logic.

### Clamping

#### RGB Clamping

To digitize the incoming signal properly, the dc offset of the input must be adjusted to fit the range of the on-board A/D converters.

Most graphics systems produce RGB signals with black at ground and white at approximately 0.75 V. However, if sync signals are embedded in the graphics, the sync tip is often at ground and black is at 300 mV. The white level will then be approximately 1.0 V. Some common RGB line amplifier boxes use emitter-follower buffers to split signals and increase drive capability. This introduces a 700 mV dc offset to the signal, which is removed by clamping for proper capture by the AD9887.

The key to clamping is to identify a portion (time) of the signal when the graphic system is known to be producing black. Originating from CRT displays, the electron beam is “blanked” by sending a black level during horizontal retrace to prevent disturbing the image. Most graphics systems maintain this format of sending a black level between active video lines.

An offset is then introduced which results in the A/D converters producing a black output (code 00h) when the known black input is present. The offset then remains in place when other signal levels are processed, and the entire signal is shifted to eliminate offset errors.

In systems with embedded sync, a blacker-than-black signal (HSYNC) is produced briefly to signal the CRT that it is time to begin a retrace. For obvious reasons, it is important to avoid

# AD9887

clamping on the tip of HSYNC. Fortunately, there is virtually always a period following HSYNC called the back porch where a good black reference is provided. This is the time when clamping should be done.

The clamp timing can be established by exercising the CLAMP pin at the appropriate time (with EXTCLMP = 1). The polarity of this signal is set by the Clamp Polarity bit.

An easier method of clamp timing employs the AD9887 internal clamp timing generator. The Clamp Placement register is programmed with the number of pixel clocks that should pass after the trailing edge of HSYNC before clamping starts. A second register (Clamp Duration) sets the duration of the clamp. These are both 8-bit values, providing considerable flexibility in clamp generation. The clamp timing is referenced to the trailing edge of HSYNC, the back porch (black reference) always follows HSYNC. A good starting point for establishing clamping is to set the clamp placement to 08h (providing eight pixel periods for the graphics signal to stabilize after sync) and set the clamp duration to 14h (giving the clamp 20 pixel periods to reestablish the black reference).

The value of the external input coupling capacitor affects the performance of the clamp. If the value is too small, there can be an amplitude change during a horizontal line time (between clamping intervals). If the capacitor is too large, it will take excessively long for the clamp to recover from a large change in incoming signal offset. The recommended value (47 nF) results in recovery from a step error of 100 mV to within 1/2 LSB in 10 lines using a clamp duration of 20 pixel periods on a 60 Hz SXGA signal.

### YUV Clamping

YUV signals are slightly different from RGB signals in that the dc reference level (black level in RGB signals) will be at the midpoint of the U and V video signal. For these signals it can be necessary to clamp to the midscale range of the A/D converter range (80h) rather than bottom of the A/D converter range (00h).

Clamping to midscale rather than ground can be accomplished by setting the clamp select bits in the serial bus register. Each of the three converters has its own selection bit so that they can be clamped to either midscale or ground independently. These bits are located in Register 0Fh and are Bits 0–2.

The midscale reference voltage that each A/D converter clamps to is provided independently on the R<sub>MIDSCV</sub>, G<sub>MIDSCV</sub>, and B<sub>MIDSCV</sub> pins. Each converter must have its own midscale reference because both offset adjustment and gain adjustment for each converter will affect the dc level of midscale.

During clamping, the Y and V converters are clamped to their respective midscale reference input. These inputs are pins B<sub>CLAMPV</sub>, and R<sub>CLAMPV</sub> for the U and V converters respectively. The typical connections for both RGB and YUV clamping are shown below in Figure 2. Note: if midscale clamping is not required, all of the midscale voltage outputs should still be connected to ground through a 0.1 μF capacitor.

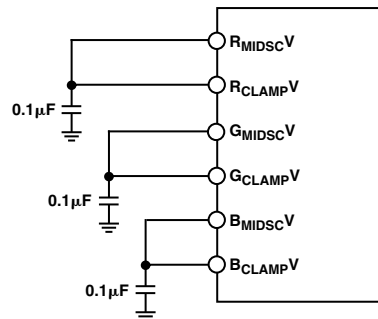

Figure 2. Typical Clamp Configuration for RBG/YUV Applications

### Gain and Offset Control

The AD9887 can accommodate input signals with inputs ranging from 0.5 V to 1.0 V full scale. The full-scale range is set in three 8-bit registers (Red Gain, Green Gain, and Blue Gain).

A code of 0 establishes a minimum input range of 0.5 V; 255 corresponds with the maximum range of 1.0 V. Note that increasing the gain setting results in an image with less contrast.

The offset control shifts the entire input range, resulting in a change in image brightness. Three 7-bit registers (Red Offset, Green Offset, Blue Offset) provide independent settings for each channel.

The offset controls provide a ±63 LSB adjustment range. This range is connected with the full-scale range, so if the input range is doubled (from 0.5 V to 1.0 V) then the offset step size is also doubled (from 2 mV per step to 4 mV per step).

Figure 3 illustrates the interaction of gain and offset controls. The magnitude of an LSB in offset adjustment is proportional to the full-scale range, so changing the full-scale range also changes the offset. The change is minimal if the offset setting is near midscale. When changing the offset, the full-scale range is not affected, but the full-scale level is shifted by the same amount as the zero-scale level.

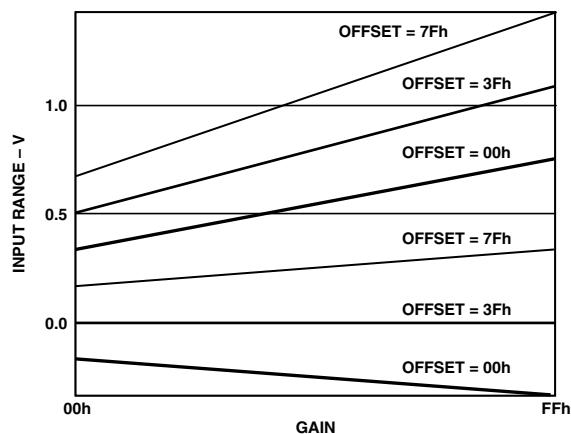

Figure 3. Gain and Offset Control

**Sync-on-Green**

The Sync-on-Green input operates in two steps. First, it sets a baseline clamp level from the incoming video signal with a negative peak detector. Second, it sets the Sync trigger level (nominally 150 mV above the negative peak). The exact trigger level is variable and can be programmed via register 11H. The Sync-on-Green input must be ac-coupled to the green analog input through its own capacitor as shown in Figure 4. The value of the capacitor must be 1 nF ± 20%. If Sync-on-Green is not used, this connection is not required and SOGIN should be left unconnected. (Note: The Sync-on-Green signal is always negative polarity.) Please refer to the Sync Processing section for more information.

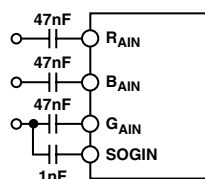

Figure 4. Typical Clamp Configuration for RGB/YUV Applications

**Clock Generation**

A Phase Locked Loop (PLL) is employed to generate the pixel clock. The HSYNC input provides a reference frequency for the PLL. A Voltage Controlled Oscillator (VCO) generates a much higher pixel clock frequency. This pixel clock is divided by the PLL divide value (Registers 01H and 02H) and phase compared with the Hsync input. Any error is used to shift the VCO frequency and maintain lock between the two signals.

The stability of this clock is a very important element in providing the clearest and most stable image. During each pixel time, there is a period when the signal is slewing from the old pixel amplitude and settling at its new value. Then there is a time when the input voltage is stable, before the signal must slew to a new value (see Figure 5). The ratio of the slewing time to the stable time is a function of the bandwidth of the graphics DAC and the bandwidth of the transmission system (cable and termination). It is also a function of the overall pixel rate. Clearly, if the dynamic characteristics of the system remain fixed, the slewing and settling times are likewise fixed. This time must be subtracted from the total pixel period, leaving the stable period. At higher pixel frequencies, the total cycle time is shorter, and the stable pixel time becomes shorter as well.

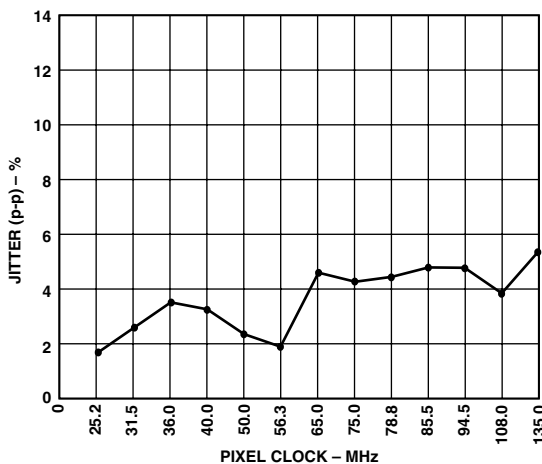

Figure 6. Pixel Clock Jitter vs. Frequency

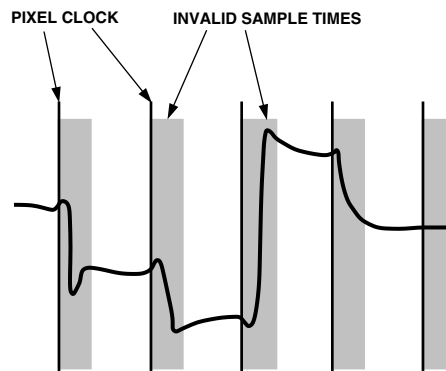

Figure 5. Pixel Sampling Times

Any jitter in the clock reduces the precision with which the sampling time can be determined, and must also be subtracted from the stable pixel time.

Considerable care has been taken in the design of the AD9887's clock generation circuit to minimize jitter. As indicated in Figure 6, the clock jitter of the AD9887 is less than 6% of the total pixel time in all operating modes, making the reduction in the valid sampling time due to jitter negligible.

The PLL characteristics are determined by the loop filter design, by the PLL charge pump current and by the VCO range setting. The loop filter design is illustrated in Figure 7. Recommended settings of VCO range and charge pump current for VESA standard display modes are listed in Table VII.

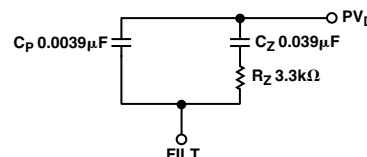

Figure 7. PLL Loop Filter Detail

Four programmable registers are provided to optimize the performance of the PLL. These registers are:

1. The 12-Bit Divisor Register. The input Hsync frequencies range from 15 kHz to 110 kHz. The PLL multiplies the frequency of the Hsync signal, producing pixel clock frequencies in the range of 12 MHz to 140 MHz. The Divisor Register controls the exact multiplication factor. This register may be set to any value between 221 and 4095. (The divide ratio that is actually used is the programmed divide ratio plus one.)
2. The 2-Bit VCO Range Register. To lower the sensitivity of the output frequency to noise on the control signal, the VCO operating frequency range is divided into four overlapping regions. The VCO Range register sets this operating range. Because there are only four possible regions, only the two least-significant bits of the VCO Range register are used. The frequency ranges for the lowest and highest regions are shown in Table V.

**Table V. VCO Frequency Ranges**

PV1	PV0	Pixel Clock Range (MHz)	K <sub>VCO</sub> Gain (MHz/V)
0	0	12–35	150
0	1	35–70	150
1	0	70–110	150
1	1	110–140	180

**Table VI. Charge Pump Current/Control Bits**

Ip2	Ip1	Ip0	Current (µA)
0	0	0	50
0	0	1	100
0	1	0	150
0	1	1	250
1	0	0	350
1	0	1	500
1	1	0	750
1	1	1	1500

3. The 3-Bit Charge Pump Current Register. This register allows the current that drives the low pass loop filter to be varied. The possible current values are listed in Table VI. provides 32 phase-shift steps of 11.25° each. The Hsync signal with an identical phase shift is available through the HSOUT pin. Phase adjustment is still available if the pixel clock is being provided externally.
4. The 5-Bit Phase Adjust Register. The phase of the generated sampling clock may be shifted to locate an optimum sampling point within a clock cycle. The Phase Adjust register The COAST allows the PLL to continue to run at the same frequency, in the absence of the incoming Hsync signal. This may be used during the vertical sync period, or any other time that the Hsync signal is unavailable. The polarity of the COAST signal may be set through the Coast Polarity Bit. Also, the polarity of the Hsync signal may be set through the HSYNC polarity Bit. If not using automatic polarity detection, the HSYNC and COAST polarity bits should be set to match the Polarity of their respective signals.

**Table VII. Recommended VCO Range and Charge Pump Current Settings for Standard Display Formats**

Standard	Resolution	Refresh Rate (Hz)	Horizontal Frequency (kHz)	Pixel Rate (MHz)	VCORNGE	CURRENT
VGA	640 × 480	60	31.5	25.175	00	101
		72	37.7	31.500	00	101
		75	37.5	31.500	00	110
		85	43.3	36.000	00	110
SVGA	800 × 600	56	35.1	36.000	00	101
		60	37.9	40.000	01	101
		72	48.1	50.000	01	101
		75	46.9	49.500	01	101
		85	53.7	56.250	01	110
XGA	1024 × 768	60	48.4	65.000	01	110
		70	56.5	75.000	10	101
		75	60.0	78.750	10	101
		80	64.0	85.500	10	101
		85	68.3	94.500	10	101
SXGA	1280 × 1024	60	64.0	108.000	10	110
		75	80.0	135.000	11	110
		85	91.1	157.500*	10	110
UXGA	1600 × 1200	60	75.0	162.000*	10	110
		65	81.3	175.500*	10	110
		70	87.5	189.000*	10	110
		75	93.8	202.500*	10	110
		85	106.3	229.500*	11	110

\*Graphics sampled at one-half the incoming pixel rate using Alternate Pixel Sampling mode.

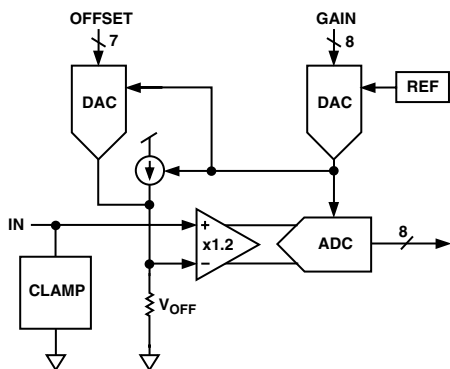

Figure 8. ADC Block Diagram (Single Channel Output)

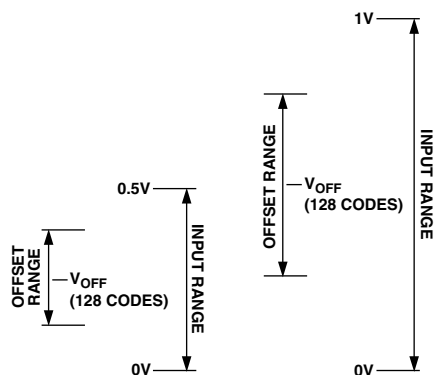

Figure 9. Relationship of Offset Range to Input Range

**SCAN Function**

The SCAN function is intended as a pseudo JTAG function for manufacturing test of the board. The ordinary operation of the AD9887 is disabled during SCAN.

To enable the SCAN function, set register 14h, bit 2 to 1. To SCAN in data to all 48 digital outputs, apply 48 serial bits of data and 48 clocks (typically 5 MHz, max of 20 MHz) to the SCAN<sub>IN</sub> and SCAN<sub>CLK</sub> pins respectively. The data is shifted in on the rising edge of SCAN<sub>CLK</sub>. The first serial bit shifted in will appear at the RED A<7> output after one clock cycle. After 48 clocks, the first bit is shifted all the way to the BLU B<0>. The 48th bit will now be at the RED A<7> output. If SCAN<sub>CLK</sub> continues after 48 cycles, the data will continue to be shifted from RED A<7> to BLU B<0> and will come out of the SCAN<sub>OUT</sub> pin as serial data on the falling edge of SCAN<sub>CLK</sub>. This is illustrated in Figure 10. A setup time ( $t_{SU}$ ) of 3 ns should be plenty and no hold time ( $t_{HOLD}$ ) is required ( $\geq 0$  ns). This is illustrated in Figure 11.

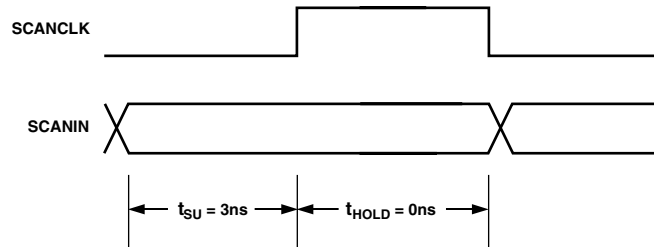

Figure 11. SCAN Setup and Hold

**Alternate Pixel Sampling Mode**

A Logic 1 input on Clock Invert (CKINV, Pin 94) inverts the nominal ADC clock. CKINV can be switched between frames to implement the alternate pixel sampling mode. This allows higher effective image resolution to be achieved at lower pixel rates but with lower frame rates.

On one frame, only even pixels are digitized. On the subsequent frame, odd pixels are sampled. By reconstructing the entire frame in the graphics controller, a complete image can be reconstructed. This is very similar to the interlacing process that is employed in broadcast television systems, but the interlacing is vertical instead of horizontal. The frame data is still presented to the display at the full desired refresh rate (usually 60 Hz) so no flicker artifacts are added.

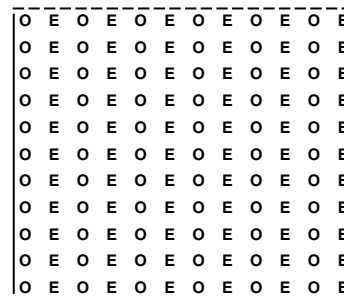

Figure 12. Odd and Even Pixels in a Frame

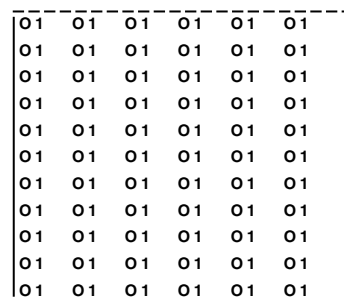

Figure 13. Odd Pixels from Frame 1

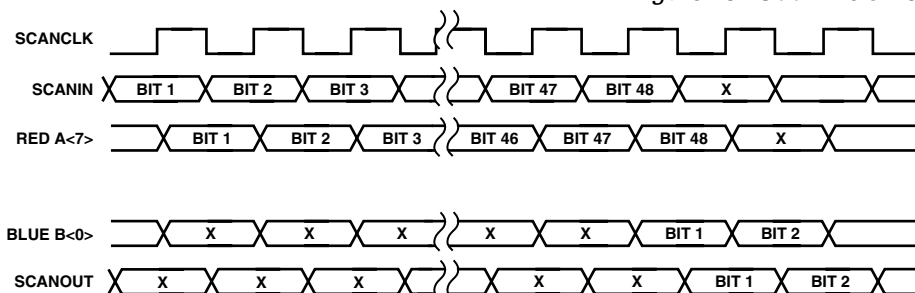

Figure 10. SCAN Timing

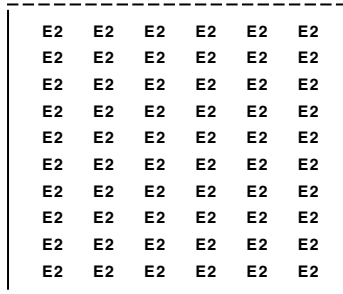

Figure 14. Even Pixels from Frame 2



Figure 15. Combine Frame Output from Graphics Controller

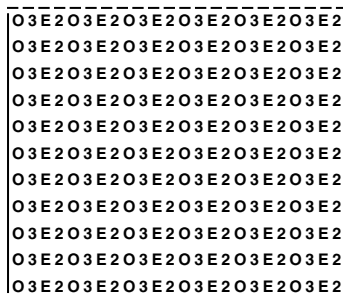

Figure 16. Subsequent Frame from Controller

### Timing (Analog Interface)

The following timing diagrams show the operation of the AD9887 analog interface in all clock modes. The part establishes timing by having the sample that corresponds to the pixel digitized when the leading edge of HSYNC occurs sent to the “A” data port. In Dual Channel Mode, the next sample is sent to the “B” port. Future samples are alternated between the “A” and “B” data ports. In Single Channel Mode, data is only sent to the “A” data port, and the “B” port is placed in a high impedance state.

The Output Data Clock signal is created so that its rising edge always occurs between “A” data transitions, and can be used to latch the output data externally.

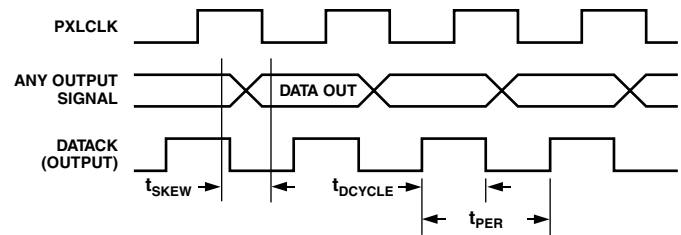

Figure 17. Analog Output Timing

### Hsync Timing

Horizontal sync is processed in the AD9887 to eliminate ambiguity in the timing of the leading edge with respect to the phase-delayed pixel clock and data.

The Hsync input is used as a reference to generate the pixel sampling clock. The sampling phase can be adjusted, with respect to Hsync, through a full 360° in 32 steps via the Phase Adjust register (to optimize the pixel sampling time). Display systems use Hsync to align memory and display write cycles, so it is important to have a stable timing relationship between Hsync output (HSOUT) and data clock (DATAACK).

Three things happen to Horizontal Sync in the AD9887. First, the polarity of Hsync input is determined and will thus have a known output polarity. The known output polarity can be programmed either active high or active low (Register 04H, Bit 4). Second, HSOUT is aligned with DATAACK and data outputs. Third, the duration of HSOUT (in pixel clocks) is set via Register 07H. HSOUT is the sync signal that should be used to drive the rest of the display system.

### Coast Timing

In most computer systems, the Hsync signal is provided continuously on a dedicated wire. In these systems, the COAST input and function are unnecessary, and should not be used.

In some systems, however, Hsync is disturbed during the Vertical Sync period (Vsync). In some cases, Hsync pulses disappear. In other systems, such as those that employ Composite Sync (Csync) signals or embed Sync-On-Green (SOG), Hsync includes equalization pulses or other distortions during Vsync. To avoid upsetting the clock generator during Vsync, it is important to ignore these distortions. If the pixel clock PLL sees extraneous pulses, it will attempt to lock to this new frequency, and will have changed frequency by the end of the Vsync period. It will then take a few lines of correct Hsync timing to recover at the beginning of a new frame, resulting in a “tearing” of the image at the top of the display.

The COAST input is provided to eliminate this problem. It is an asynchronous input that disables the PLL input and allows the clock to free-run at its then-current frequency. The PLL can free-run for several lines without significant frequency drift.

Coast can be provided by the graphics controller or it can be internally generated by the AD9887 Sync processing engine.

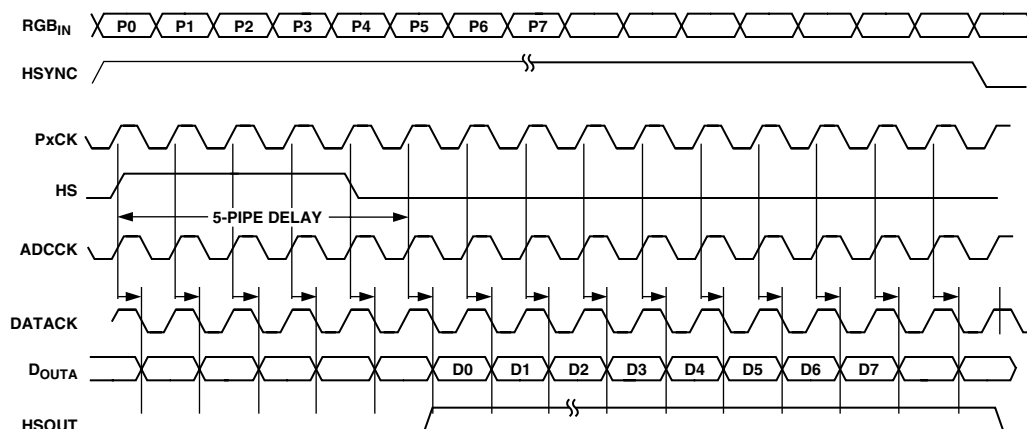

Figure 18. Single Channel Mode (Analog Interface)

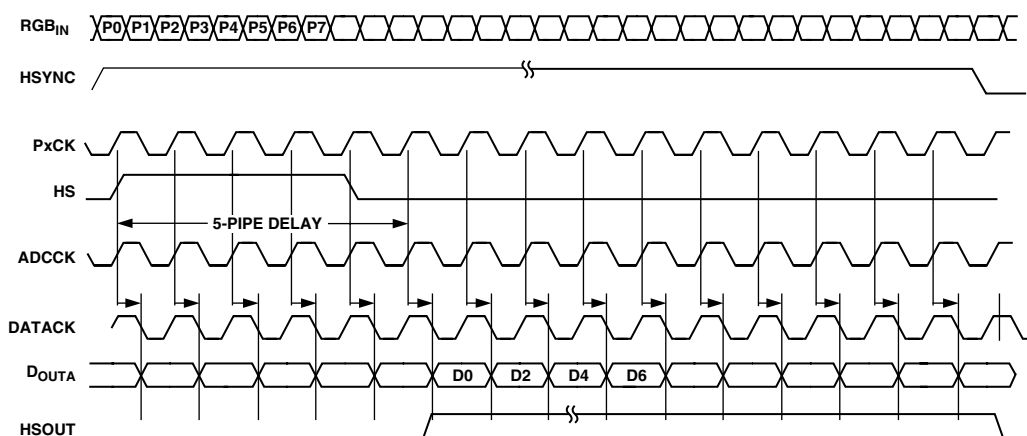

Figure 19. Single Channel Mode, 2 Pixels/Clock (Even Pixels) (Analog Interface)

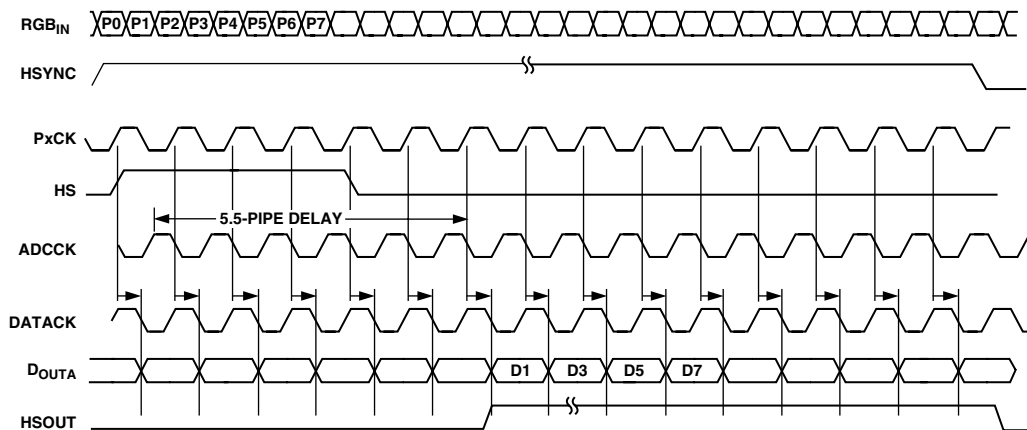

Figure 20. Single Channel Mode, 2 Pixels/Clock (Odd Pixels) (Analog Interface)

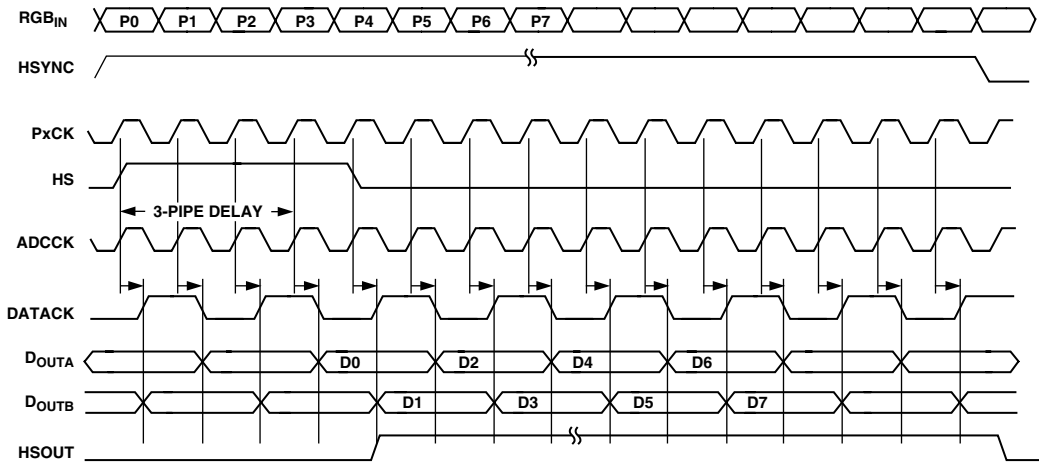

Figure 21. Dual Channel Mode, Interleaved Outputs (Analog Interface), Outphase = 1

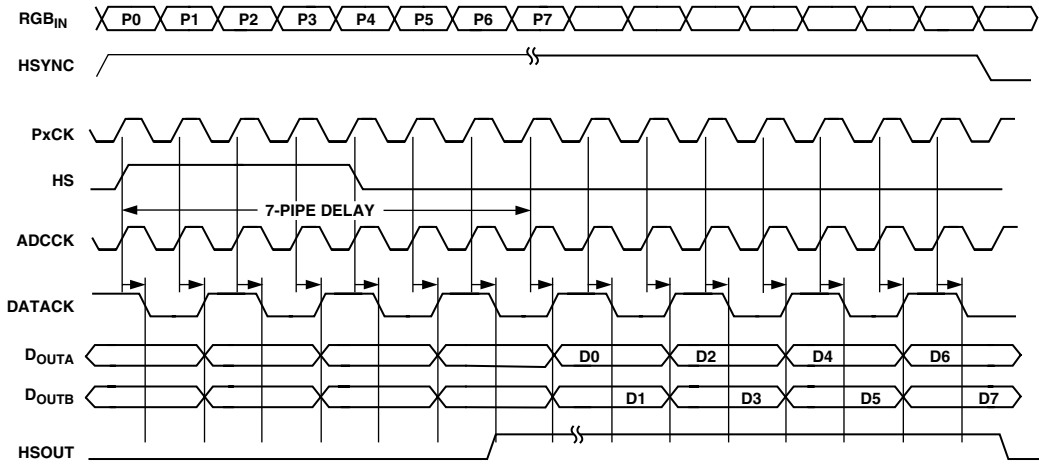

Figure 22. Dual Channel Mode, Parallel Outputs (Analog Interface), Outphase = 1

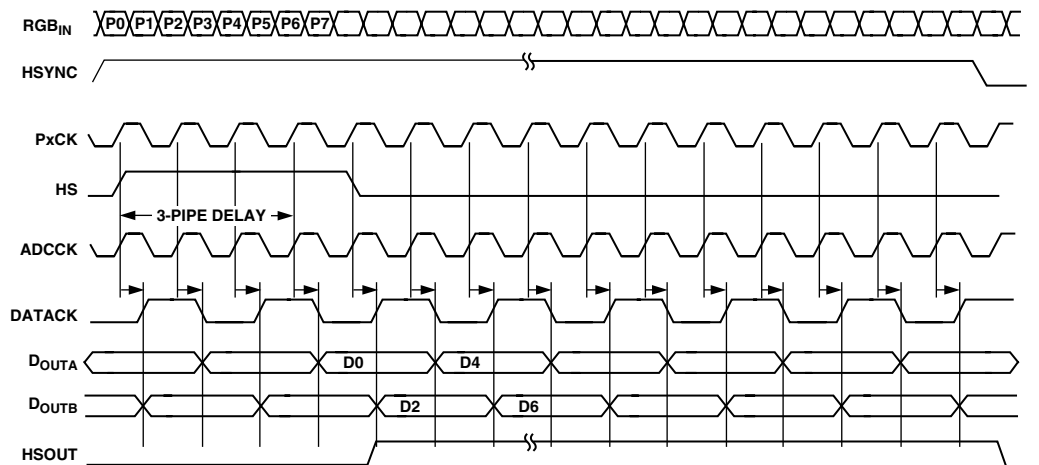

Figure 23. Dual Channel Mode, Interleaved Outputs, 2 Pixels/Clock (Even Pixels) (Analog Interface), Outphase = 1

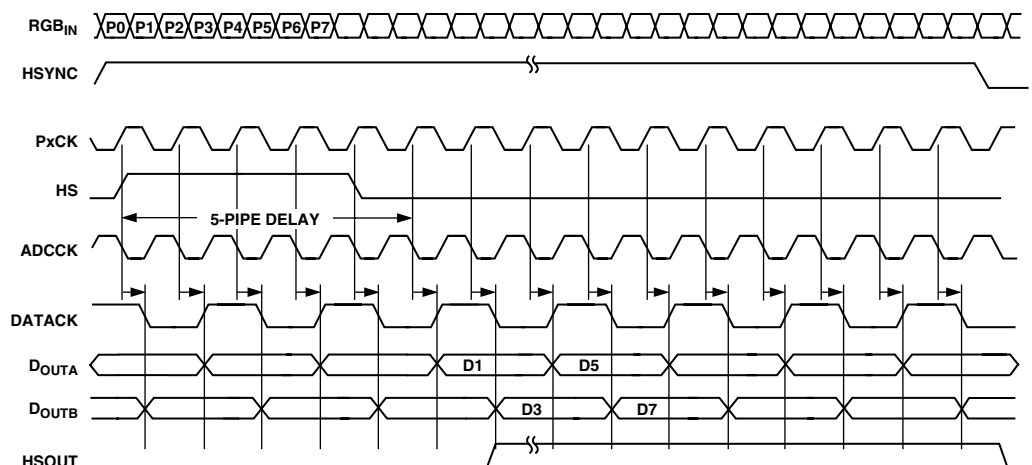

Figure 24. Dual Channel Mode, Interleaved Outputs, 2 Pixels/Clock (Odd Pixels) (Analog Interface), Outphase = 1

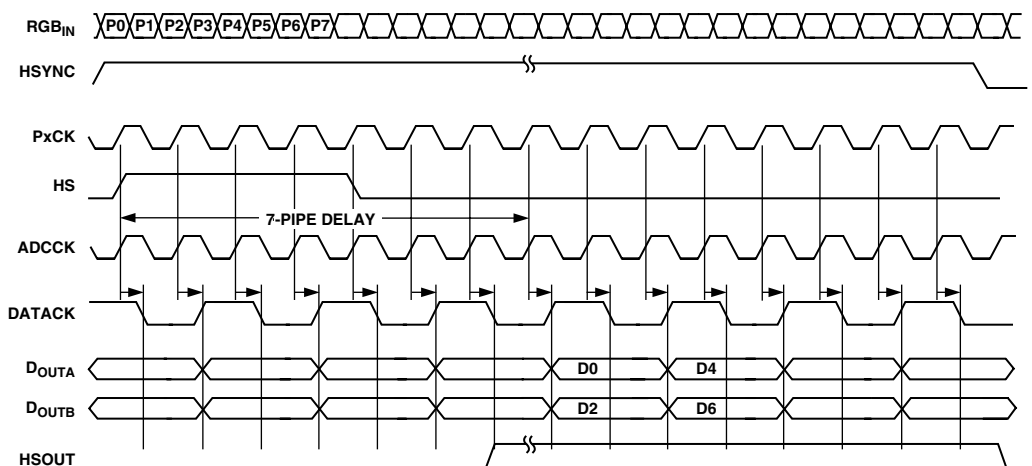

Figure 25. Dual Channel Mode, Parallel Outputs, 2 Pixels/Clock (Even Pixels) (Analog Interface), Outphase = 1

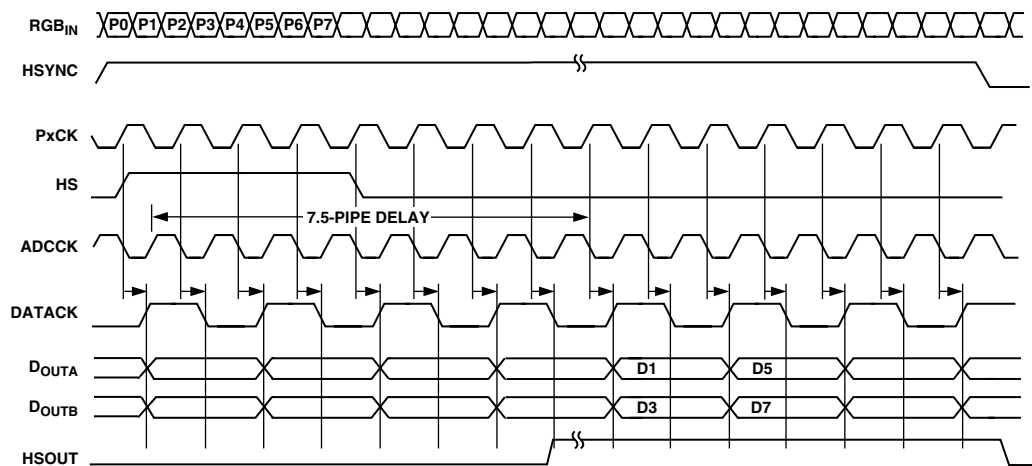

Figure 26. Dual Channel Mode, Parallel Outputs, 2 Pixels/Clock (Odd Pixels) (Analog Interface), Outphase = 1

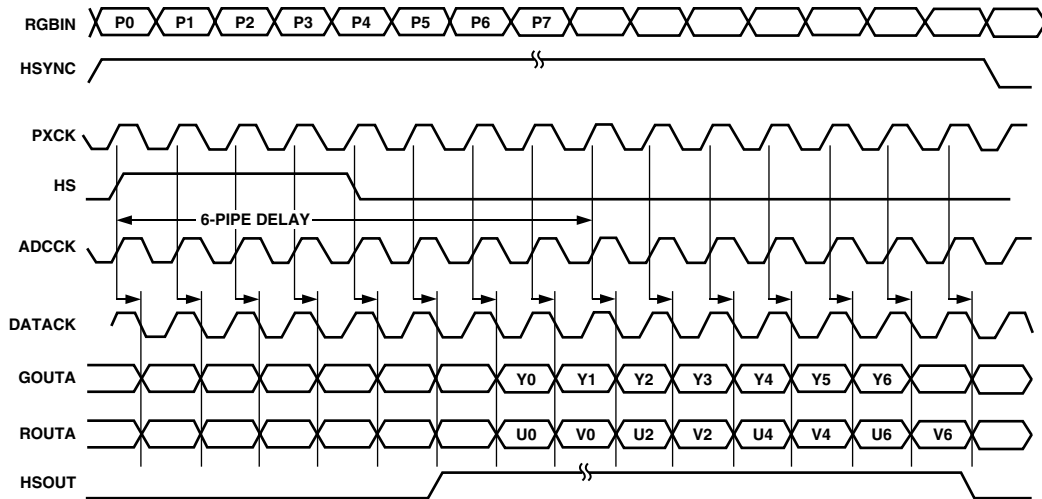

Figure 27. 4:2:2 Output Mode

Table VIII. Digital Interface Pin List

Pin Type	Pin Name	Function	Value	Pin No.
Digital Video Data Inputs	Rx0+	Digital Input Channel 0 True		62
	Rx0-	Digital Input Channel 0 Complement		63
	Rx1+	Digital Input Channel 1 True		59
	Rx1-	Digital Input Channel 1 Complement		60
	Rx2+	Digital Input Channel 2 True		56
	Rx2-	Digital Input Channel Two's Complement		57
Digital Video Clock Inputs	RxC+	Digital Data Clock True		65
	RxC-	Digital Data Clock Complement		66
Termination Control	R <sub>TERM</sub>	Control Pin for Setting the Internal Termination Resistance		53
Outputs	DE	Data Enable	3.3 V CMOS	137
	HSYNC	HSYNC Output	3.3 V CMOS	139
	VSYNC	VSYNC Output	3.3 V CMOS	138
	CTL0, CTL1, CTL2, CTL3	Decoded Control Bit Outputs	3.3 V CMOS	46-49
Power Supply	V <sub>D</sub>	Main Power Supply	3.3 V ± 5%	
	PV <sub>D</sub>	PLL Power Supply	3.3 V ± 5%	
	V <sub>DD</sub>	Output Power Supply	3.3 V or 2.5 V ± 5%	
	GND	Ground Supply	0 V	
	GND	Ground Supply	0 V	

**DIGITAL INTERFACE PIN DESCRIPTIONS****Digital Video Data Inputs**

Rx0+	Positive Differential Input Video Data (Channel 0)
Rx0-	Negative Differential Input Video Data (Channel 0)
Rx1+	Positive Differential Input Video Data (Channel 1)
Rx1-	Negative Differential Input Video Data (Channel 1)
Rx2+	Positive Differential Input Video Data (Channel 2)
Rx2-	Negative Differential Input Video Data (Channel 2)

These six pins receive three pairs of differential, low voltage swing input pixel data from a digital graphics transmitter.

**Digital Video Clock Inputs**

RxC+	Positive Differential Input Video Clock
RxC-	Negative Differential Input Video Clock

These two pins receive the differential, low voltage swing input pixel clock from a digital graphics transmitter.

**Termination Control**

R <sub>TERM</sub>	Internal Termination Set Pin
-------------------	------------------------------

This pin is used to set the termination resistance for all of the digital interface high-speed inputs. To set, place a resistor of value equal to 10× the desired input termination resistance between this pin (Pin 53) and ground supply. Typically, the value of this resistor should be 500 Ω.

**Outputs**

DE	Data Enable Output
----	--------------------

This pin outputs the state of data enable, (DE). The AD9887 decodes DE from the incoming stream of data. The DE signal will be HIGH during active video and will be LOW while there is no active video.

**Power Supply**

V <sub>D</sub>	Main Power Supply
----------------	-------------------

It should be as quiet and as filtered as possible.

PV <sub>D</sub>	PLL Power Supply
-----------------	------------------

It should be as quiet and as filtered as possible.

V <sub>DD</sub>	Outputs Power Supply
-----------------	----------------------

The power for the data and clock outputs. It can run at 3.3 V or 2.5 V.

**THEORY OF OPERATION (DIGITAL INTERFACE)****Capturing of the Encoded Data**

The first step in recovering the encoded data is to capture the raw data. To accomplish this, the AD9887 employs a high-speed Phase Locked Loop (PLL), to generate clocks capable of oversampling the data at the correct frequencies. The data capture circuitry continuously monitors the incoming data during horizontal and vertical blanking times (when DE is low), and independently selects the best sampling phase for each data channel. The phase information is stored and used until the next blanking period (one video line).

**Data Frames**

The digital interface data is captured in groups of 10 bits each, called a data frame. During the active data period, each frame is made up the nine encoded video data bits and one dc balancing bit. The data capture block receives this data serially, but outputs each frame in parallel 10-bit words.

**Special Characters**

During periods of horizontal or vertical blanking time (when DE is low), the digital transmitter will transmit special characters. The AD9887 will receive these characters and use them to set the video frame boundaries and the phase recovery loop for each channel. There are four special characters that can be received. They are used to identify the top, bottom, left side, and right side of each video frame. The data receiver can differentiate these special characters from active data because the special characters have a different number of transitions per data frame.

**Channel Resynchronization**

The purpose of the channel resynchronization block is to resynchronize the three data channels to a single internal data clock. Coming into this block, all three data channels can be on different phases of the three times oversampling PLL clock (0°, 120°, and 240°). This block can resynchronize the channels from a worst-case skew of one full input period (8.93 ns at 112 MHz).

**Data Decoder**

The data decoder receives frames of data and sync signals from the data capture block (in 10-bit parallel words), and decodes them into groups of eight RGB/YUV bits, two control bits, and a data enable bit (DE).

## GENERAL TIMING DIAGRAMS (DIGITAL INTERFACE)

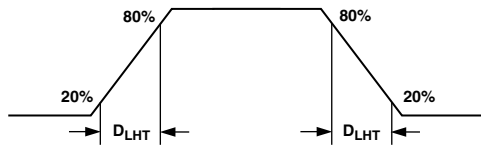

Figure 28. Digital Output Rise and Fall Time

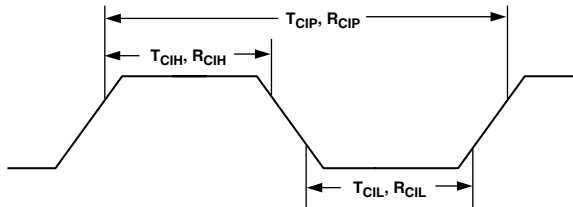

Figure 29. Clock Cycle/High/Low Times

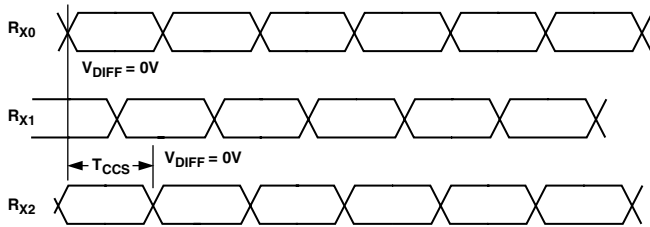

Figure 30. Channel-to-Channel Skew Timing

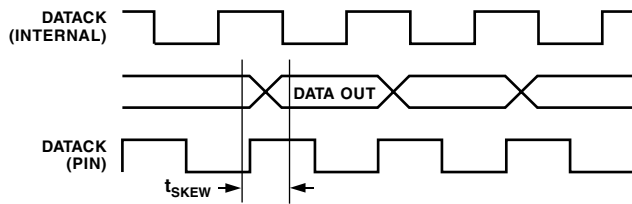

Figure 31. DVI Output Timing

## TIMING MODE DIAGRAMS (DIGITAL INTERFACE)

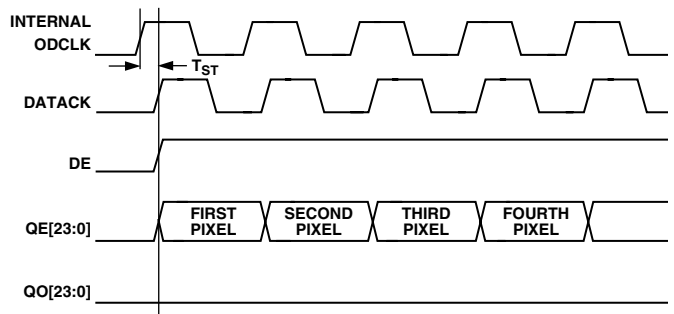

Figure 32. 1 Pixel per Clock (DATAACK Inverted)

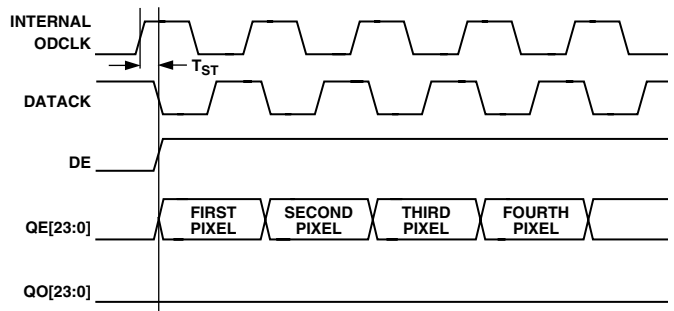

Figure 33. 1 Pixels per Clock (DATAACK Inverted)

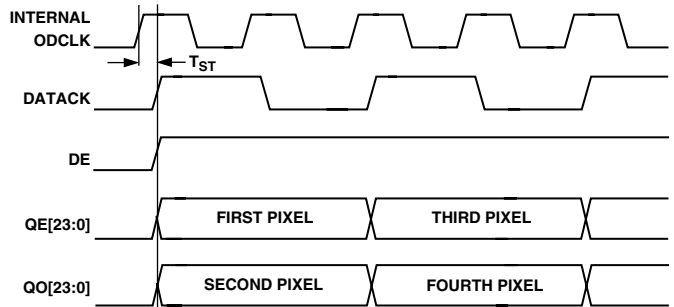

Figure 34. 2 Pixel per Clock

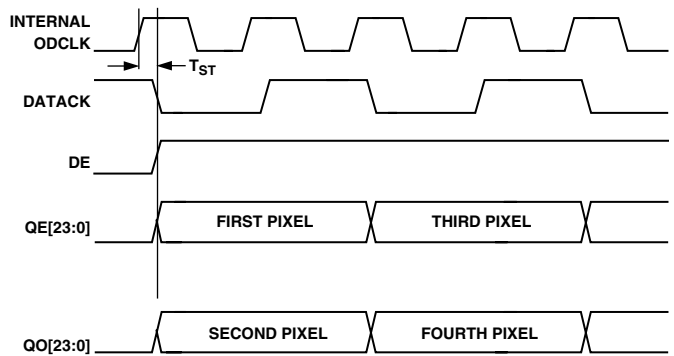

Figure 35. 2 Pixels per Clock (DATAACK Inverted)

## 2-Wire Serial Register Map

The AD9887 is initialized and controlled by a set of registers, which determine the operating modes. An external controller is employed to write and read the Control Registers through the 2-line serial interface port.

**Table IX. Control Register Map**

Hex Address	Read and Write or Read Only	Bits	Default Value	Register Name	Function
00H	RO	7:0		Chip Revision	Bits 7 through 4 represent functional revisions to the analog interface. Bits 3 through 0 represent nonfunctional related revisions. Revision 0 = 0000 0000
01H	R $\overline{W}$	7:0	01101001	PLL Div MSB	This register is for Bits [11:4] of the PLL divider. Larger values mean the PLL operates at a faster rate. This register should be loaded first whenever a change is needed. (This will give the PLL more time to lock.) See Note 1.
02H	R $\overline{W}$	7:4	1101****	PLL Div LSB	Bits [7:4] LSBs of the PLL divider word. See Note 1.
03H	R $\overline{W}$	7:2	1***** *01*****  ***001**	VCO/CPMP	Bit 7—Must be set to 1 for proper device operation. Bits [6:5] VCO Range. Selects VCO frequency range. (See PLL description.) Bits [4:2] Charge Pump Current. Varies the current that drives the low-pass filter. (See PLL description.)
04H	R $\overline{W}$	7:3	10000***	Phase Adjust	ADC Clock phase adjustment. Larger values mean more delay. (1 LSB = T/32)
05H	R $\overline{W}$	7:0	10000000	Clamp Placement	Places the Clamp signal an integer number of clock periods after the trailing edge of the Hsync signal.
06H	R $\overline{W}$	7:0	10000000	Clamp Duration	Number of clock periods that the Clamp signal is actively clamping.
07H	R $\overline{W}$	7:0	00100000	Hsync Output Pulsewidth	Sets the number of pixel clocks that HSOUT will remain active.
08H	R $\overline{W}$	7:0	10000000	Red Gain	Controls ADC input range (Contrast) of each respective channel. Bigger values give less contrast.
09H	R $\overline{W}$	7:0	10000000	Green Gain	
0AH	R $\overline{W}$	7:0	10000000	Blue Gain	
0BH	R $\overline{W}$	7:1	1000000*	Red Offset	Controls dc offset (Brightness) of each respective channel. Bigger values decrease brightness.
0CH	R $\overline{W}$	7:1	1000000*	Green Offset	
0DH	R $\overline{W}$	7:1	1000000*	Blue Offset	
0EH	R $\overline{W}$	7:3	1*****  *1*****  **0*****  ***0*****  ****0***	Mode Control 1	Bit 7—Channel Mode. Determines Single Channel or Dual Channel Output Mode. (Logic 0 = Single Channel Mode, Logic 1 = Dual Channel Mode.) Bit 6—Output Mode. Determine Interleaved or Parallel Output Mode. (Logic 0 = Interleaved Mode, Logic 1 = Parallel Mode.) Bit 5—OUTPHASE. Determines which port outputs the first data byte after Hsync. (Logic 0 = B Port, Logic 1 = A Port.) Bit 4—Hsync Output polarity. (Logic 0 = Logic High Sync, Logic 1 = Logic Low Sync.) Bit 3—Vsync Output Invert. (Logic 0 = Invert, Logic 1 = No Invert.)

Table IX. Control Register Map (continued)

Hex Address	Read and Write or Read Only	Bits	Default Value	Register Name	Function
0FH	R $\overline{W}$	7:0	1***** *1***** **0***** ***1**** ****0*** *****0** *****0* *****0	PLL and Clamp Control	<p>Bit 7—HSYNC Polarity. Indicates the polarity of incoming HSYNC signal to the PLL. (Logic 0 = Active Low, Logic 1 = Active High.)</p> <p>Bit 6—Coast Polarity. Changes polarity of external COAST signal. (Logic 0 = Active Low, Logic 1 = Active High.)</p> <p>Bit 5—Clamp Function. Chooses between HSYNC for Clamp signal or another external signal to be used for clamping. (Logic 0 = HSYNC, Logic 1 = Clamp.)</p> <p>Bit 4—Clamp Polarity. Valid only with external CLAMP signal. (Logic 0 = Active Low, Logic 1 selects Active High.)</p> <p>Bit 3—EXTCLK. Shuts down the PLL and allows the use of an external clock to drive the part. (Logic 0 = use internal PLL, Logic 1 = bypassing of the internal PLL.)</p> <p>Bit 2—Red Clamp Select—Logic 0 selects clamp to ground. Logic 1 selects clamp to midscale (voltage at Pin 120).</p> <p>Bit 1—Green Clamp Select—Logic 0 selects clamp to ground. Logic 1 selects clamp to midscale (voltage at Pin 111).</p> <p>Bit 0—Blue Clamp Select—Logic 0 selects clamp to ground. Logic 1 selects clamp to midscale (voltage at Pin 101).</p>
10H	R $\overline{W}$	7:2	0***** *0***** **11**** ****0*** *****1**	Mode Control 2	<p>Bit 7—Clk Inv: Data clock output invert. (Logic 0 = Not Inverted, Logic 1 = Inverted.) (Digital Interface Only.)</p> <p>Bit 6—Pix Select: Selects either 1 or 2 pixels per clock mode. (Logic 0 = 1 pixel/clock, Logic 1 = 2 pixels/clock.) (Digital Interface Only.)</p> <p>Bit 5, 4—Output Drive: Selects between high, medium, and low output drive strength. (Logic 11 or 10 = High, 01 = Medium, and 00 = Low.)</p> <p>Bit 3—P<sub>DO</sub>: High Impedance Outputs. (Logic 0 = Normal, Logic 1 = High Impedance.)</p> <p>Bit 2—Sync Detect (SyncDT) Polarity. This bit sets the polarity for the SyncDT output pin. (Logic 1 = Active High, Logic 0 = Active Low.)</p>
11H	RO	7:1		Sync Detect/ Active Interface	<p>Bit 7—Analog Interface Hsync Detect. It is set to Logic 1 if Hsync is present on the analog interface; otherwise it is set to Logic 0.</p> <p>Bit 6—Analog Interface Sync-on-Green Detect. It is set to Logic 1 if sync is present on the green video input; otherwise it is set to 0.</p> <p>Bit 5—Analog Interface Vsync Detect. It is set to Logic 1 if Vsync is present on the analog interface; otherwise it is set to Logic 0.</p> <p>Bit 4—Digital Interface Clock Detect. It is set to Logic 1 if the clock is present on the digital interface; otherwise it is set to Logic 0.</p> <p>Bit 3—AI: Active Interface. This bit indicates which interface is active. (Logic 0 = Analog Interface, Logic 1 = Digital Interface.)</p> <p>Bit 2—AHS: Active Hsync. This bit indicates which analog HSYNC is being used. (Logic 0 = HSYNC Input Pin, Logic 1 = HSYNC from Sync-on-Green.)</p> <p>Bit 1—AVS: Active Vsync. This bit indicates which analog VSYNC is being used. (Logic 0 = VSYNC input pin, Logic 1 = VSYNC from sync separator.)</p>

Table IX. Control Register Map (continued)

Hex Address	Read and Write or Read Only	Bits	Default Value	Register Name	Function
12H	R/ $\overline{W}$	7:0	0***** *0***** **0***** ***0**** ****0*** *****0** *****0* *****1	Active Interface	<p>Bit 7—AIO: Active Interface Override. If set to Logic 1, the user can select the active interface via Bit 6. If set to Logic 0, the active interface is selected via Bit 3 in Register 11H.</p> <p>Bit 6—AIS: Active Interface Select. Logic 0 selects the analog interface as active. Logic 1 selects the digital interface as active. Note: The indicated interface will be active only if Bit 7 is set to Logic 1 or if both interfaces are active (Bits 6 or 7 and 4 = Logic 1 in Register 11H.)</p> <p>Bit 5—Active Hsync Override. If set to Logic 1, the user can select the Hsync to be used via Bit 4. If set to Logic 0, the active interface is selected via Bit 2 in Register 11H.</p> <p>Bit 4—Active Hsync Select. Logic 0 selects Hsync as the active sync. Logic 1 selects Sync-on-Green as the active sync. Note: The indicated Hsync will be used only if Bit 5 is set to Logic 1 or if both syncs are active (Bits 6, 7 = Logic 1 in Register 11H.)</p> <p>Bit 3—Active Vsync Override. If set to Logic 1, the user can select the Vsync to be used via Bit 2. If set to Logic 0, the active interface is selected via Bit 1 in Register 11H.</p> <p>Bit 2—Active Vsync Select. Logic 0 selects Raw Vsync as the output Vsync. Logic 1 selects Sync Separated Vsync as the output Vsync. Note: The indicated Vsync will be used only if Bit 3 is set to Logic 1.</p> <p>Bit 1—Coast Select. Logic 0 selects the coast input pin to be used for the PLL coast. Logic 1 selects Vsync to be used for the PLL coast.</p> <p>Bit 0—<math>\overline{PWRDN}</math>. Full Chip Power-Down, active low. (Logic 0 = Full Chip Power-Down, Logic 1 = Normal.)</p>
13H	R/ $\overline{W}$	7:0	00100000	Sync Separator Threshold	Sync Separator Threshold—Sets the number of clocks the sync separator will count to before toggling high or low. This should be set to some number greater than the maximum Hsync or equalization pulsewidth.
14H	R/ $\overline{W}$	7:0	***1**** ****0*** *****0** *****0* *****0	Control Bits	<p>Bit 4—Must be set to 1 for proper operation.</p> <p>Bit 3—Must be set to 0 for proper operation.</p> <p>Bit 2—Scan Enable. (Logic 0 = Not Enabled, Logic 1 = Enabled.)</p> <p>Bit 1—Coast Polarity Override. (Logic 0 = Polarity determined by chip, Logic 1 = Polarity set by Bit 6 in Register 0Fh.)</p> <p>Bit 0—Hsync Polarity Override. (Logic 0 = Polarity determined by chip, Logic 1 = Polarity set by Bit 7 in Register 0Fh.)</p>
15H	RO	7:5		Polarity Status	<p>Bit 7—Hsync Input Polarity Status. (Logic 1 = Active High, Logic 0 = Active Low.)</p> <p>Bit 6—Vsync Output Polarity Status. (Logic 0 = Active High, Logic 1 = Active Low.)</p> <p>Bit 5—Coast Input Polarity Status. (Logic 1 = Active High, Logic 0 = Active Low.)</p>
16H	R/ $\overline{W}$	7:2	10111*** *****1*	Control Bits 2	<p>Bits [7:3]—Sync-On-Green Slicer Threshold</p> <p>Bit 1—Must be set to 0 for proper operation.</p>
17H	R/ $\overline{W}$	7:0	00000000	Pre-Coast	Sets the number of Hsyncs that coast goes active prior to Vsync.
18H	R/ $\overline{W}$	7:0	00000000	Post-Coast	Sets the number of Hsyncs that coast goes active following Vsync.
19H	R/ $\overline{W}$	7:0	00000000	Test Register	Must be set to default for proper operation.
1AH	R/ $\overline{W}$	7:0	11111111	Test Register	Must be set to 01000001 for proper operation.

# AD9887

**Table IX. Control Register Map (continued)**

Hex Address	Read and Write or Read Only	Bits	Default Value	Register Name	Function
1BH	R $\overline{W}$	7:0	00000000	Test Register	Must be set to 00010000 for proper operation.
1CH	R $\overline{W}$	7:0	000001** *****1* *****1	4:2:2 Control	Bits [7:2]—Must be set to 011011** for proper operation. Bit 1—Must be set to default for proper operation. Bit 0—Output Format Mode Select Logic 1 = 4:4:4 mode Logic 0 = 4:2:2 mode
1DH	RO	7:0		Test Register	Reserved for future use.
1EH	RO	7:0		Test Register	Reserved for future use.
1FH	RO	7:0		Test Register	Reserved for future use.

**NOTE**

<sup>1</sup>The AD9887 only updates the PLL divide ratio when the LSBs are written to (Register 02h).

## 2-WIRE SERIAL CONTROL REGISTER DETAIL

### CHIP IDENTIFICATION

#### 00 7-0 Chip Revision

Bits 7 through 4 represent functional revisions to the analog interface. Changes in these bits will generally indicate that software and/or hardware changes will be required for the chip to work properly. Bits 3 through 0 represent nonfunctional related revisions and are reset to 0000 whenever the MSBs are changed. Changes in these bits are considered transparent to the user.

### PLL DIVIDER CONTROL

#### 01 7-0 PLL Divide Ratio MSBs

The eight most significant bits of the 12-bit PLL divide ratio PLLDIV. (The operational divide ratio is PLLDIV + 1.)

The PLL derives a pixel clock from the incoming Hsync signal. The pixel clock frequency is then divided by an integer value, such that the output is phase-locked to Hsync. This PLLDIV value determines the number of pixel times (pixels plus horizontal blanking overhead) per line. This is typically 20% to 30% more than the number of active pixels in the display.

The 12-bit value of the PLL divider supports divide ratios from 221 to 4095. The higher the value loaded in this register, the higher the resulting clock frequency with respect to a fixed Hsync frequency.

VESA has established some standard timing specifications, which will assist in determining the value for PLLDIV as a function of horizontal and vertical display resolution and frame rate (Table VII).

However, many computer systems do not conform precisely to the recommendations, and these numbers should be used only as a guide. The display system manufacturer should provide automatic or manual means for optimizing PLLDIV. An incorrectly set PLLDIV will usually produce one or more vertical noise bars on the display. The greater the error, the greater the number of bars produced.

The power-up default value of PLLDIV is 1693 (PLLDIVM = 69h, PLLDIVL = Dxh).

The AD9887 updates the full divide ratio only when the LSBs are changed. Writing to this register by itself will not trigger an update.

#### 02 7-4 PLL Divide Ratio LSBs

The four least significant bits of the 12-bit PLL divide ratio PLLDIV. The operational divide ratio is PLLDIV + 1.

The power-up default value of PLLDIV is 1693 (PLLDIVM = 69h, PLLDIVL = Dxh).

The AD9887 updates the full divide ratio only when this register is written.

### CLOCK GENERATOR CONTROL

#### 03 7 TEST Set to One

#### 03 6-5 VCO Range Select

Two bits that establish the operating range of the clock generator.

VCORNGE must be set to correspond with the desired operating frequency (incoming pixel rate).

The PLL gives the best jitter performance at high frequencies. For this reason, in order to output low pixel rates and still get good jitter performance, the PLL actually operates at a higher frequency but then divides down the clock rate afterwards. Table X shows the pixel rates for each VCO range setting. The PLL output divisor is automatically selected with the VCO range setting.

Table X. VCO Ranges

VCORNGE	Pixel Rate Range
00	12-35
01	35-70
10	70-110
11	110-140

The power-up default value is = 01.

#### 03 4-2 CURRENT Charge Pump Current

Three bits that establish the current driving the loop filter in the clock generator.

Table XI. Charge Pump Currents

CURRENT	Current ( $\mu$ A)
000	50
001	100
010	150
011	250
100	350
101	500
110	750
111	1500

See Table VII for the recommended CURRENT settings.

The power-up default value is CURRENT = 001.

#### 04 7-3 Clock Phase Adjust

A five-bit value that adjusts the sampling phase in 32 steps across one pixel time. Each step represents an 11.25° shift in sampling phase.

The power-up default value is 16.

### CLAMP TIMING

#### 05 7-0 Clamp Placement

An eight-bit register that sets the position of the internally generated clamp.

When EXTCLMP = 0, a clamp signal is generated internally, at a position established by the clamp placement and for a duration set by the clamp duration. Clamping is started (Clamp Placement) pixel periods after the trailing edge of Hsync. The clamp placement may be programmed to any value between 1 and 255. A value of 0 is not supported.

The clamp should be placed during a time that the input signal presents a stable black-level reference, usually the back porch period between Hsync and the image.

When EXTCLMP = 1, this register is ignored.

# AD9887

## 06 7-0 Clamp Duration

An 8-bit register that sets the duration of the internally generated clamp.

When EXTCLMP = 0, a clamp signal is generated internally, at a position established by the clamp placement and for a duration set by the clamp duration. Clamping is started (clamp placement) pixel periods after the trailing edge of Hsync, and continues for (clamp duration) pixel periods. The clamp duration may be programmed to any value between 1 and 255. A value of 0 is not supported.

For the best results, the clamp duration should be set to include the majority of the black reference signal time that follows the Hsync signal trailing edge. Insufficient clamping time can produce brightness changes at the top of the screen, and a slow recovery from large changes in the Average Picture Level (APL), or brightness.

When EXTCLMP = 1, this register is ignored.

## Hsync Pulsewidth

### 07 7-0 Hsync Output Pulsewidth

An 8-bit register that sets the duration of the Hsync output pulse.

The leading edge of the Hsync output is triggered by the internally generated, phase-adjusted PLL feedback clock. The AD9887 then counts a number of pixel clocks equal to the value in this register. This triggers the trailing edge of the Hsync output, which is also phase-adjusted.

## INPUT GAIN

### 08 7-0 Red Channel Gain Adjust

An 8-bit word that sets the gain of the RED channel. The AD9887 can accommodate input signals with a full-scale range of between 0.5 V and 1.5 V p-p. Setting REDGAIN to 255 corresponds to an input range of 1.0 V. A REDGAIN of 0 establishes an input range of 0.5 V. Note that INCREASING REDGAIN results in the picture having LESS CONTRAST (the input signal uses fewer of the available converter codes). See Figure 3.

### 09 7-0 Green Channel Gain Adjust

An 8-bit word that sets the gain of the GREEN channel. See REDGAIN (08).

### 0A 7-0 Blue Channel Gain Adjust

An 8-bit word that sets the gain of the BLUE channel. See REDGAIN (08).

## INPUT OFFSET

### 0B 7-1 Red Channel Offset Adjust

A 7-bit offset binary word that sets the dc offset of the RED channel. One LSB of offset adjustment equals approximately one LSB change in the ADC offset. Therefore, the absolute magnitude of the offset adjustment scales as the gain of the channel is changed. A nominal setting of 63 results in the channel nominally clamping the back porch (during the clamping interval) to Code 00. An offset setting of 127 results in the channel clamping to Code 63 of the ADC. An offset setting of 0 clamps to code -63 (off the bottom of the range). Increasing the value of Red Offset DECREASES the brightness of the channel.

### 0C 7-1 Green Channel Offset Adjust

A 7-bit offset binary word that sets the dc offset of the GREEN channel. See REDOFST (0B).

### 0D 7-1 Blue Channel Offset Adjust

A 7-bit offset binary word that sets the dc offset of the GREEN channel. See REDOFST (0B).

## MODE CONTROL 1

### 0E 7 Channel Mode

A bit that determines whether all pixels are presented to a single port (A), or alternating pixels are demultiplexed to Ports A and B.

Table XII. Channel Mode Settings

DEMUX	Function
0	All Data Goes to Port A
1	Alternate Pixels Go to Port A and Port B

When DEMUX = 0, Port B outputs are in a high-impedance state. The maximum data rate for single port mode is 100 MHz. The timing diagrams show the effects of this option.

The power-up default value is 1.

### 0E 6 Output Mode

A bit that determines whether all pixels are presented to Port A and Port B simultaneously on every second DATAACK rising edge, or alternately on port A and Port B on successive DATAACK rising edges.

Table XIII. Output Mode Settings

PARALLEL	Function
0	Data Is Interleaved
1	Data Is Simultaneous On Every Other Data Clock

When in single port mode (DEMUX = 0), this bit is ignored. The timing diagrams show the effects of this option.

The power-up default value is PARALLEL = 1.

### 0E 5 Output Port Phase

One bit that determines whether even pixels or odd pixels go to Port A.

Table XIV. Output Port Phase Settings

OUTPHASE	First Pixel After Hsync
0	Port B
1	Port A

In normal operation (OUTPHASE = 1), when operating in dual-port output mode (DEMUX = 1), the first sample after the Hsync leading edge is presented at Port A. Every subsequent ODD sample appears at Port A. All EVEN samples go to Port B.

When OUTPHASE = 0, these ports are reversed and the first sample goes to Port B.

When DEMUX = 0, this bit is ignored as data always comes out of only Port A.

#### 0E 4 HSYNC Output Polarity

One bit that determines the polarity of the HSYNC output and the SOG output. Table XV shows the effect of this option. SYNC indicates the logic state of the sync pulse.

**Table XV. HSYNC Output Polarity Settings**

Setting	SYNC
0	Logic 1 (Positive Polarity)
1	Logic 0 (Negative Polarity)

The default setting for this register is 1. (This option works on both the analog and digital interfaces.)

#### 0E 3 VSYNC Output Invert

One bit that inverts the polarity of the VSYNC output. Table XVI shows the effect of this option.

**Table XVI. VSYNC Output Polarity Settings**

Setting	VSYNC Output
0	Invert
1	No Invert

The default setting for this register is 1. (This option works on both the analog and digital interfaces.)

#### 0F 7 HSYNC Input Polarity

A bit that must be set to indicate the polarity of the HSYNC signal that is applied to the PLL HSYNC input.

**Table XVII. HSYNC Input Polarity Settings**

HSPOL	Function
0	Active LOW
1	Active HIGH

Active LOW is the traditional negative-going Hsync pulse. All timing is based on the leading edge of Hsync, which is the FALLING edge. The rising edge has no effect.

Active HIGH is inverted from the traditional Hsync, with a positive-going pulse. This means that timing will be based on the leading edge of Hsync, which is now the RISING edge.

The device will operate if this bit is set incorrectly, but the internally generated clamp position, as established by CLPOS, will not be placed as expected, which may generate clamping errors.

The power-up default value is HSPOL = 1.

#### 0F 6 COAST Input Polarity

A bit to indicate the polarity of the COAST signal that is applied to the PLL COAST input.

**Table XVIII. COAST Input Polarity Settings**

CSTPOL	Function
0	Active LOW
1	Active HIGH

Active LOW means that the clock generator will ignore Hsync inputs when COAST is LOW, and continue operating at the same nominal frequency until COAST goes HIGH.

Active HIGH means that the clock generator will ignore Hsync inputs when COAST is HIGH, and continue operating at the same nominal frequency until COAST goes LOW.

This function needs to be used along with the COAST polarity override bit (Register 14, Bit 1).

The power-up default value is CSTPOL = 1.

#### 0F 5 Clamp Input Signal Source

A bit that determines the source of clamp timing.

**Table XIX. Clamp Input Signal Source Settings**

EXTCLMP	Function
0	Internally-Generated Clamp
1	Externally-Provided Clamp Signal

A 0 enables the clamp timing circuitry controlled by CLPLACE and CLDUR. The clamp position and duration is counted from the leading edge of Hsync.

A 1 enables the external CLAMP input pin. The three channels are clamped when the CLAMP signal is active. The polarity of CLAMP is determined by the CLAMPOL bit.

The power-up default value is EXTCLMP = 0.

#### 0F 4 CLAMP Input Signal Polarity

A bit that determines the polarity of the externally provided CLAMP signal.

**Table XX. CLAMP Input Signal Polarity Settings**

EXTCLMP	Function
0	Active LOW
1	Active HIGH

A Logic 0 means that the circuit will clamp when CLAMP is HIGH, and it will pass the signal to the ADC when CLAMP is LOW.

A Logic 1 means that the circuit will clamp when CLAMP is LOW, and it will pass the signal to the ADC when CLAMP is HIGH.

The power-up default value is CLAMPOL = 1.

#### 0F 3 External Clock Select

A bit that determines the source of the pixel clock.

**Table XXI. External Clock Select Settings**

EXTCLK	Function
0	Internally Generated Clock
1	Externally Provided Clock Signal

A Logic 0 enables the internal PLL that generates the pixel clock from an externally provided Hsync.

A Logic 1 enables the external CKEXT input pin. In this mode, the PLL Divide Ratio (PLLDIV) is ignored. The clock phase adjust (PHASE) is still functional.

The power-up default value is EXTCLK = 0.

## 0F 2 Red Clamp Select

A bit that determines whether the red channel is clamped to ground or to midscale. For RGB video, all three channels are referenced to ground. For YcbCr (or YUV), the Y channel is referenced to ground, but the CbCr channels are referenced to midscale. Clamping to midscale actually clamps to Pin 118,  $R_{CLAMPV}$ .

**Table XXII. Red Clamp Select Settings**

Clamp	Function
0	Clamp to Ground
1	Clamp to Midscale (Pin 118)

The default setting for this register is 0.

## 0F 1 Green Clamp Select

A bit that determines whether the green channel is clamped to ground or to midscale.

**Table XXIII. Green Clamp Select Settings**

Clamp	Function
0	Clamp to Ground
1	Clamp to Midscale (Pin 109)

The default setting for this register is 0.

## 0F 0 Blue Clamp Select

A bit that determines whether the blue channel is clamped to ground or to midscale.

**Table XXIV. Blue Clamp Select Settings**

Clamp	Function
0	Clamp to Ground
1	Clamp to Midscale (Pin 99)

The default setting for this register is 0.

## MODE CONTROL 2

### 10 7 Clk Inv Data Output Clock Invert

A control bit for the inversion of the output data clocks, (Pins 134, 135). This function works only for the digital interface. When not inverted, data is output on the rising edge of the data clock. See timing diagrams to see how this affects timing.

**Table XXV. Clock Output Invert Settings**

Clk Inv	Function
0	Not Inverted
1	Inverted

The default for this register is 0, not inverted.

### 10 6 Pix Select

This bit selects either 1 or 2 pixels per clock mode for the digital interface. It determines whether the data comes out

of a single port (even port only), at the full data rate or out of two ports (both even and odd ports), at one-half the full data rate per port. A Logic 0 selects 1 pixel per clock (even port only). A Logic 1 selects 2 pixels per clock (both ports). See the Digital Interface Timing Diagrams, Figures 29 to 32, for a visual representation of this function. Note: This function operates exactly like the DEMUX function on the analog interface.

**Table XXVI. Pix Select Settings**

Pix Select	Function
0	1 Pixel per Clock
1	2 Pixels per Clock

The default for this register is 0, 1 pixel per clock.

### 10 5, 4 Output Drive

These two bits select the drive strength for the high-speed digital outputs (all data output and clock output pins). Higher drive strength results in faster rise/fall times and in general makes it easier to capture data. Lower drive strength results in slower rise/fall times and helps to reduce EMI and digitally generated power supply noise. The exact timing specifications for each of these modes are specified in Table VII.

**Table XXVII. Output Drive Strength Settings**

Bit 5	Bit 4	Result
1	1	High Drive Strength
1	0	Medium Drive Strength
0	X	Low Drive Strength

The default for this register is 11, high drive strength. (This option works on both the analog and digital interfaces.)

### 10 3 P<sub>DO</sub>—Power-Down Outputs

A bit that can put the outputs in a high impedance mode. This applies only to the 48 data output pins and the two data clock output pins.

**Table XXVIII. Power-Down Output Settings**

CKINV	Function
0	Normal Operation
1	Three-State

The default for this register is 0. (This option works on both the analog and digital interfaces.)

### 10 2 Sync Detect Polarity

This pin controls the polarity of the Sync Detect output pin (Pin 136).

**Table XXIX. Sync Detect Polarity Settings**

Polarity	Function
0	Activity = Logic 1 Output
1	Activity = Logic 0 Output

The default for this register is 0. (This option works on both the analog and digital interfaces.)

**SYNC DETECTION AND CONTROL****11 7 Analog Interface HSYNC Detect**

This bit is used to indicate when activity is detected on the HSYNC input pin (Pin 82). If HSYNC is held high or low, activity will not be detected.

**Table XXX. HSYNC Detection Results**

Detect	Function
0	No Activity Detected
1	Activity Detected

Figure 38 shows where this function is implemented.

**11 6 Analog Interface Sync-on-Green Detect**

This bit is used to indicate when sync activity is detected on the Sync-on-Green input pin (Pin 108).

**Table XXXI. Sync-on-Green Detection Results**

Detect	Function
0	No Activity Detected
1	Activity Detected

Figure 38 shows where this function is implemented.

**Warning:** If no sync is present on the green video input, normal video may still trigger activity.

**11 5 Analog Interface VSYNC Detect**

This bit is used to indicate when activity is detected on the VSYNC input pin (Pin 81). If VSYNC is held high or low, activity will not be detected.

**Table XXXII. VSYNC Detection Results**

Detect	Function
0	No Activity Detected
1	Activity Detected

Figure 38 shows where this function is implemented.

**11 4 Digital Interface Clock Detect**

This bit is used to indicate when activity is detected on the digital interface clock input.

**Table XXXIII. Digital Interface Clock Detection Results**

Detect	Function
0	No Activity Detected
1	Activity Detected

The sync processing block diagram shows where this function is implemented.

**11 3 Active Interface**

This bit is used to indicate which interface should be active, analog, or digital. It checks for activity on the analog interface and for activity on the digital interface, then determines which should be active according to Table XXXIV. Specifically, analog interface detection is determined by OR-ing Bits 7, 6, and 5 in this register.

Digital interface detection is determined by Bit 4 in this register. If both interfaces are detected, the user can determine which has priority via Bit 6 in register 12H. The user can override this function via Bit 7 in Register 12H. If the override bit is set to Logic 1, then this bit will be forced to whatever the state of Bit 6 in Register 12H is set to.

**Table XXXIV. Active Interface Results**

Bits 7, 6, or 5 (Analog Detection)	Bit 4 (Digital Detection)	Override	AI
0	0	0	Soft Power-Down (Seek Mode)
0	1	0	1
1	0	0	0
1	1	0	Bit 6 in 12H
X	X	1	Bit 6 in 12H

AI = 0 means Analog Interface.

AI = 1 means Digital Interface.

The override bit is in Register 12H, Bit 7.

**11 2 AHS—Active HSYNC**

This bit is used to determine which HSYNC should be used for the analog interface, the HSYNC input or Sync-on-Green. It uses Bits 7 and 6 in this register for inputs in determining which should be active. Similar to the previous bit, if both HSYNC and SOG are detected the user can determine which has priority via Bit 4 in Register 12H. The user can override this function via Bit 5 in Register 12H. If the override bit is set to Logic 1, this bit will be forced to whatever the state of Bit 4 in Register 12H is set to.

**Table XXXV. Active HSYNC Results**

Bit 7 (HSYNC Detect)	Bit 6 (SOG Detect)	Override	AHS
0	0	0	Bit 4 in 12H
0	1	0	1
1	0	0	0
1	1	0	Bit 4 in 12H
X	X	1	Bit 4 in 12H

AHS = 0 means use the HSYNC pin input for HSYNC.

AHS = 1 means use the SOG pin input for HSYNC.

The override bit is in Register 12H, Bit 5.

**11 1 AVS—Active VSYNC**

This bit is used to determine which VSYNC should be used for the analog interface; the VSYNC input or output from the sync separator. If both VSYNC and composite SOG are detected, VSYNC will be selected. The user can override this function via Bit 3 in Register 12H. If the override bit is set to Logic 1, this bit will be forced to whatever the state of Bit 2 in Register 12H is set to.

Table XXXVI. Active VSYNC Results

Bit 5 (VSYNC Detect)	Override	AVS
0	0	0
1	0	1
X	1	Bit 2 in 12H

AVS = 1 means Sync separator.

AVS = 0 means VSYNC input.

The override bit is in Register 12H, Bit 3.

#### 12 7 AIO—Active Interface Override

This bit is used to override the automatic interface selection (Bit 3 in Register 11H). To override, set this bit to Logic 1. When overriding, the active interface is set via Bit 6 in this register.

Table XXXVII. Active Interface Override Settings

AIO	Result
0	Autodetermines the Active Interface
1	Override, Bit 6 Determines the Active Interface

The default for this register is 0.

#### 12 6 AIS—Active Interface Select

This bit is used under two conditions. It is used to select the active interface when the override bit is set (Bit 7). Alternately, it is used to determine the active interface when not overriding but both interfaces are detected.

Table XXXVIII. Active Interface Select Settings

AIS	Result
0	Analog Interface
1	Digital Interface

The default for this register is 0.

#### 12 5 Active Hsync Override

This bit is used to override the automatic Hsync selection (Bit 2 in Register 11H). To override, set this bit to Logic 1. When overriding, the active Hsync is set via Bit 4 in this register.

Table XXXIX. Active Hsync Override Settings

Override	Result
0	Autodetermines the Active Interface
1	Override, Bit 4 Determines the Active Interface

The default for this register is 0.

#### 12 4 Active Hsync Select

This bit is used under two conditions. It is used to select the active Hsync when the override bit is set (Bit 5). Alternately, it is used to determine the active Hsync when not overriding but both Hsyncs are detected.

Table XL. Active HSYNC Select Settings

Select	Result
0	HSYNC Input
1	Sync-on-Green Input

The default for this register is 0.

#### 12 3 Active VSYNC Override

This bit is used to override the automatic VSYNC selection (Bit 1 in Register 11H). To override, set this bit to Logic 1. When overriding, the active interface is set via Bit 2 in this register.

Table XLI. Active VSYNC Override Settings

Override	Result
0	Autodetermines the Active VSYNC
1	Override, Bit 2 Determines the Active VSYNC

The default for this register is 0.

#### 12 2 Active VSYNC Select

This bit is used to select the active VSYNC when the override bit is set (Bit 3).

Table XLII. Active VSYNC Select Settings

Select	Result
0	VSYNC Input
1	Sync Separator Output

The default for this register is 0.

#### 12 1 COAST Select

This bit is used to select the active COAST source. The choices are the COAST input pin or VSYNC. If VSYNC is selected, the additional decision of using the VSYNC input pin or the output from the sync separator needs to be made (Bits 3, 2).

Table XLIII. COAST Select Settings

Select	Result
0	COAST Input Pin
1	VSYNC (See Above Text)

The default for this register is 0.

#### 12 0 PWRDN

This bit is used to put the chip in full power-down. This powers down both interfaces. See the section on Power Management for details of which blocks are actually powered down. Note, the chip will be unable to detect incoming activity while fully powered-down.

Table XLIV. Power-Down Settings

Select	Result
0	Power-Down
1	Normal Operation

The default for this register is 1.

**DIGITAL CONTROL****13 7:0 Sync Separator Threshold**

This register is used to set the responsiveness of the sync separator. It sets how many pixel clock pulses the sync separator must count to before toggling high or low. It works like a low-pass filter to ignore Hsync pulses in order to extract the Vsync signal. This register should be set to some number greater than the maximum Hsync pulsewidth. The default for this register is 32.

**CONTROL BITS****14 2 Scan Enable**

This register is used to enable the scan function. When enabled, data can be loaded into the AD9887 outputs serially with the scan function. The scan function utilizes three pins (SCAN<sub>IN</sub>, SCAN<sub>OUT3</sub>, and SCAN<sub>CLK</sub>). These pins are described in Table I.

**Table XLV. Scan Enable Settings**

Scan Enable	Result
0	Scan Function Disabled
1	Scan Function Enabled

The default for scan enable is 0 (disabled).

**14 1 Coast Input Polarity Override**

This register is used to override the internal circuitry that determines the polarity of the coast signal going into the PLL.

**Table XLVI. Coast Input Polarity Override Settings**

Override Bit	Result
0	Coast Polarity Determined by Chip
1	Coast Polarity Determined by User

The default for coast polarity override is 0 (polarity determined by chip).

**14 0 HSYNC Input Polarity Override**

This register is used to override the internal circuitry that determines the polarity of the Hsync signal going into the PLL.

**Table XLVII. HSYNC Input Polarity Override Settings**

Override Bit	Result
0	Hsync Polarity Determined by Chip
1	Hsync Polarity Determined by User

The default for Hsync polarity override is 0 (polarity determined by chip).

**15 7 HSYNC Input Polarity Status**

This bit reports the status of the Hsync input polarity detection circuit. It can be used to determine the polarity of the Hsync input. The detection circuit's location is shown in the Sync Processing Block Diagram (Figure 38).

**Table XLVIII. Detected HSYNC Input Polarity Status**

Hsync Polarity Status	Result
0	Hsync Polarity is Negative.
1	Hsync Polarity is Positive.

**15 6 VSYNC Output Polarity Status**

This bit reports the status of the Vsync output polarity detection circuit. It can be used to determine the polarity of the Vsync input. The detection circuit's location is shown in the Sync Processing Block Diagram (Figure 38).

**Table XLIX. Detected VSYNC Input Polarity Status**

Vsync Polarity Status	Result
0	Vsync Polarity is Active Low.
1	Vsync Polarity is Active High.

**15 5 Coast Input Polarity Status**

This bit reports the status of the coast input polarity detection circuit. It can be used to determine the polarity of the coast input. The detection circuit's location is shown in the Sync Processing Block Diagram (Figure 38).

**Table L. Detected Coast Input Polarity Status**

Coast Polarity Status	Result
0	Coast Polarity is Negative.
1	Coast Polarity is Positive.

**16 7-3 Sync-on-Green Slicer Threshold**

This register allows the comparator threshold of the Sync-on-Green slicer to be adjusted. This register adjusts the comparator threshold in steps of 10 mV. A setting of zero results in a 330 mV threshold. The setting of 31 results in a 10 mV threshold.

The default setting is 23 and corresponds to a threshold value of 70 mV.

**17 7-0 Pre-Coast**

This register allows the Coast signal to be applied prior to the Vsync signal. This is necessary in cases where pre-equalization pulses are present. The step size for this control is one Hsync period.

The default is 0.

**18 7-0 Post-Coast**

This register allows the coast signal to be applied following to the Vsync signal. This is necessary in cases where post-equalization pulses are present. The step size for this control is one Hsync period.

The default is 0.

**19 7-0 Test Register**

Must be set to default.

**1A 7-0 Test Register**

Must be set to 41H for proper operation.

# AD9887

## 1B 7-0 Test Register

Must be set to 10H for proper operation.

## 1C 7-2 Test Bits

Must be set to 6FH for proper operation.

## 1C 1 Output Format Mode Select

A bit that configures the output data in 4:2:2 mode. This mode can be used to reduce the number of data lines used from 24 down to 16 for applications using YUV, YCbCr, or YPbPr graphics signals. A timing diagram for this mode is shown on page 22. Recommended input and output configurations are shown in Table LI. In 4:2:2 mode, the red and blue channels can be interchanged to help satisfy board layout or timing requirements, but the green channel must be configured for Y.

**Table LI. 4:2:2 Output Mode Select**

Select	Output Mode
1	4:4:4
1	4:2:2

**Table LII. 4:2:2 Input/Output Configuration**

Channel	Input Connection	Output Format
Red	V	U/V
Green	Y	Y
Blue	U	High Impedance

## 1C 1-0 Test Bits

Must be set to default.

## 2-WIRE SERIAL CONTROL PORT

A 2-wire serial interface control interface is provided. Up to four AD9887 devices may be connected to the 2-wire serial interface, with each device having a unique address.

The 2-wire serial interface comprises a clock (SCL) and a bidirectional data (SDA) pin. The Analog Flat Panel Interface acts as a slave for receiving and transmitting data over the serial interface. When the serial interface is not active, the logic levels on SCL and SDA are pulled HIGH by external pull-up resistors.

Data received or transmitted on the SDA line must be stable for the duration of the positive-going SCL pulse. Data on SDA must change only when SCL is LOW. If SDA changes state while SCL is HIGH, the serial interface interprets that action as a start or stop sequence.

There are five components to serial bus operation:

- Start Signal
- Slave Address Byte
- Base Register Address Byte
- Data Byte to Read or Write
- Stop Signal

When the serial interface is inactive (SCL and SDA are HIGH) communications are initiated by sending a start signal. The start signal is a HIGH-to-LOW transition on SDA while SCL is HIGH. This signal alerts all slaved devices that a data transfer sequence is coming.

The first eight bits of data transferred after a start signal comprising a 7-bit slave address (the first seven bits) and a single  $R\overline{W}$  bit (the

eighth bit). The  $R\overline{W}$  bit indicates the direction of data transfer, read from (1) or write to (0) the slave device. If the transmitted slave address matches the address of the device (set by the state of the SA<sub>1-0</sub> input pins in Table LIII, the AD9887 acknowledges by bringing SDA LOW on the 9th SCL pulse. If the addresses do not match, the AD9887 does not acknowledge.

**Table LIII. Serial Port Addresses**

Bit 7 A <sub>6</sub> (MSB)	Bit 6 A <sub>5</sub>	Bit 5 A <sub>4</sub>	Bit 4 A <sub>3</sub>	Bit 3 A <sub>2</sub>	Bit 2 A <sub>1</sub>	Bit 1 A <sub>0</sub>
1	0	0	1	1	0	0
1	0	0	1	1	0	1
1	0	0	1	1	1	0
1	0	0	1	1	1	1

## Data Transfer via Serial Interface

For each byte of data read or written, the MSB is the first bit of the sequence.

If the AD9887 does not acknowledge the master device during a write sequence, the SDA remains HIGH so the master can generate a stop signal. If the master device does not acknowledge the AD9887 during a read sequence, the AD9887 interprets this as “end of data.” The SDA remains HIGH so the master can generate a stop signal.

Writing data to specific control registers of the AD9887 requires that the 8-bit address of the control register of interest be written after the slave address has been established. This control register address is the base address for subsequent write operations. The base address autoincrements by one for each byte of data written after the data byte intended for the base address. If more bytes are transferred than there are available addresses, the address will not increment and remain at its maximum value of 1Dh. Any base address higher than 1Dh will not produce an acknowledge signal.

Data is read from the control registers of the AD9887 in a similar manner. Reading requires two data transfer operations:

The base address must be written with the  $R\overline{W}$  bit of the slave address byte LOW to set up a sequential read operation.

Reading (the  $R\overline{W}$  bit of the slave address byte HIGH) begins at the previously established base address. The address of the read register autoincrements after each byte is transferred.

To terminate a read/write sequence to the AD9887, a stop signal must be sent. A stop signal comprises a LOW-to-HIGH transition of SDA while SCL is HIGH.

A repeated start signal occurs when the master device driving the serial interface generates a start signal without first generating a stop signal to terminate the current communication. This is used to change the mode of communication (read, write) between the slave and master without releasing the serial interface lines.

## Serial Interface Read/Write Examples

Write to one control register

- ➔ Start signal
- ➔ Slave Address byte ( $R\overline{W}$  bit = LOW)
- ➔ Base Address byte
- ➔ Data byte to base address
- ➔ Stop signal

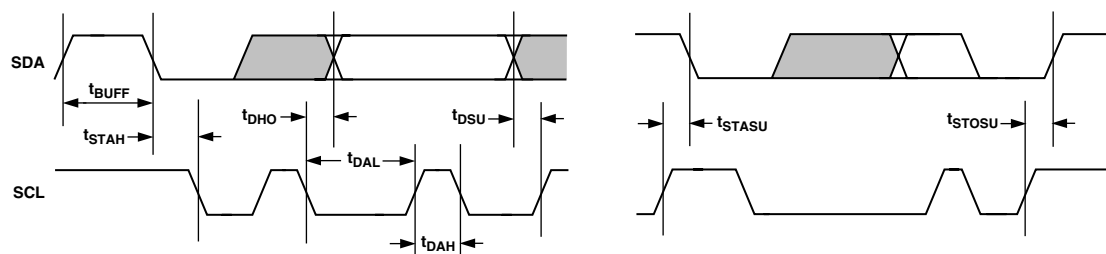

Figure 36. Serial Port Read/Write Timing

Write to four consecutive control registers

- ➔ Start signal
- ➔ Slave Address byte ( $R/\overline{W}$  bit = LOW)
- ➔ Base Address byte
- ➔ Data byte to base address
- ➔ Data byte to (base address + 1)
- ➔ Data byte to (base address + 2)
- ➔ Data byte to (base address + 3)
- ➔ Stop signal

Read from one control register

- ➔ Start signal
- ➔ Slave Address byte ( $R/\overline{W}$  bit = LOW)
- ➔ Base Address byte
- ➔ Start signal
- ➔ Slave Address byte ( $R/\overline{W}$  bit = HIGH)
- ➔ Data byte from base address
- ➔ Stop signal

Read from four consecutive control registers

- ➔ Start signal
- ➔ Slave Address byte ( $R/\overline{W}$  bit = LOW)
- ➔ Base Address byte
- ➔ Start signal
- ➔ Slave Address byte ( $R/\overline{W}$  bit = HIGH)
- ➔ Data byte from base address
- ➔ Data byte from (base address + 1)
- ➔ Data byte from (base address + 2)
- ➔ Data byte from (base address + 3)
- ➔ Stop signal

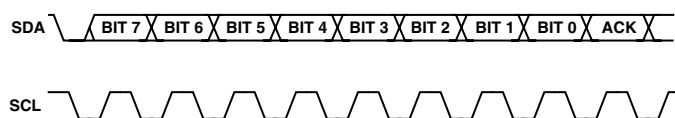

Figure 37. Serial Interface – Typical Byte Transfer

**Table LIV. Control of the Sync Block Muxes via the Serial Register**

Mux Nos.	Serial Bus Control Bit	Control Bit State	Result
1 and 2	12H: Bit 4	0	Pass Hsync
		1	Pass Sync-on-Green
3	12H: Bit 1	0	Pass Coast
		1	Pass Vsync
4	12H: Bit 2	0	Pass Vsync
		1	Pass Sync Separator Signal
5, 6, and 7	11H: Bit 3	0	Pass Digital Interface Signals
		1	Pass Analog Interface Signals

## THEORY OF OPERATION (SYNC PROCESSING)

This section is devoted to the basic operation of the sync processing engine (refer to Figure 37 Sync Processing Block Diagram).

### Sync Slicer

The purpose of the sync slicer is to extract the sync signal from the green graphics channel. A sync signal is not present on all graphics systems, only those with “sync-on-green.” The sync signal is extracted from the green channel in a two step process. First, the SOG input is clamped to its negative peak (typically 0.3 V below the black level). Next, the signal goes to a comparator with a trigger level that is 0.15 V above the clamped level. The “sliced” sync is typically a composite sync signal containing both Hsync and Vsync.

### Sync Separator

A sync separator extracts the Vsync signal from a composite sync signal. It does this through a low-pass filter-like or integrator-like operation. It works on the idea that the Vsync signal stays active for a much longer time than the Hsync signal, so it rejects any signal shorter than a threshold value, which is somewhere between an Hsync pulsewidth and a Vsync pulsewidth.

The sync separator on the AD9887 is simply an 8-bit digital counter with a 5 MHz clock. It works independently of the polarity of the composite sync signal. (Polarities are determined elsewhere on the chip.) The basic idea is that the counter counts up when Hsync pulses are present. But since Hsync pulses are relatively short in width, the counter only reaches a value of N before the pulse ends. It then starts counting down eventually reaching 0 before the next Hsync pulse arrives. The specific value of N will vary for different video modes, but will always be less than 255. For example with a 1  $\mu$ s width Hsync, the counter will only reach 5 ( $1 \mu\text{s}/200 \text{ ns} = 5$ ). Now, when Vsync is present on the composite sync the counter will also count up. However, since the Vsync signal is much longer, it will count to a higher number M. For most video modes, M will be at least 255. So, Vsync can be detected on the composite sync signal by detecting when the counter counts to higher than N. The specific count that triggers detection (T) can be programmed through the serial register (0fh).

Once Vsync has been detected, there is a similar process to detect when it goes inactive. At detection, the counter first resets to 0, then starts counting up when Vsync goes away. Similar to the previous case, it will detect the absence of Vsync when the counter reaches the threshold count (T). In this way, it will reject noise and/or serration pulses. Once Vsync is detected to be absent, the counter resets to 0 and begins the cycle again.

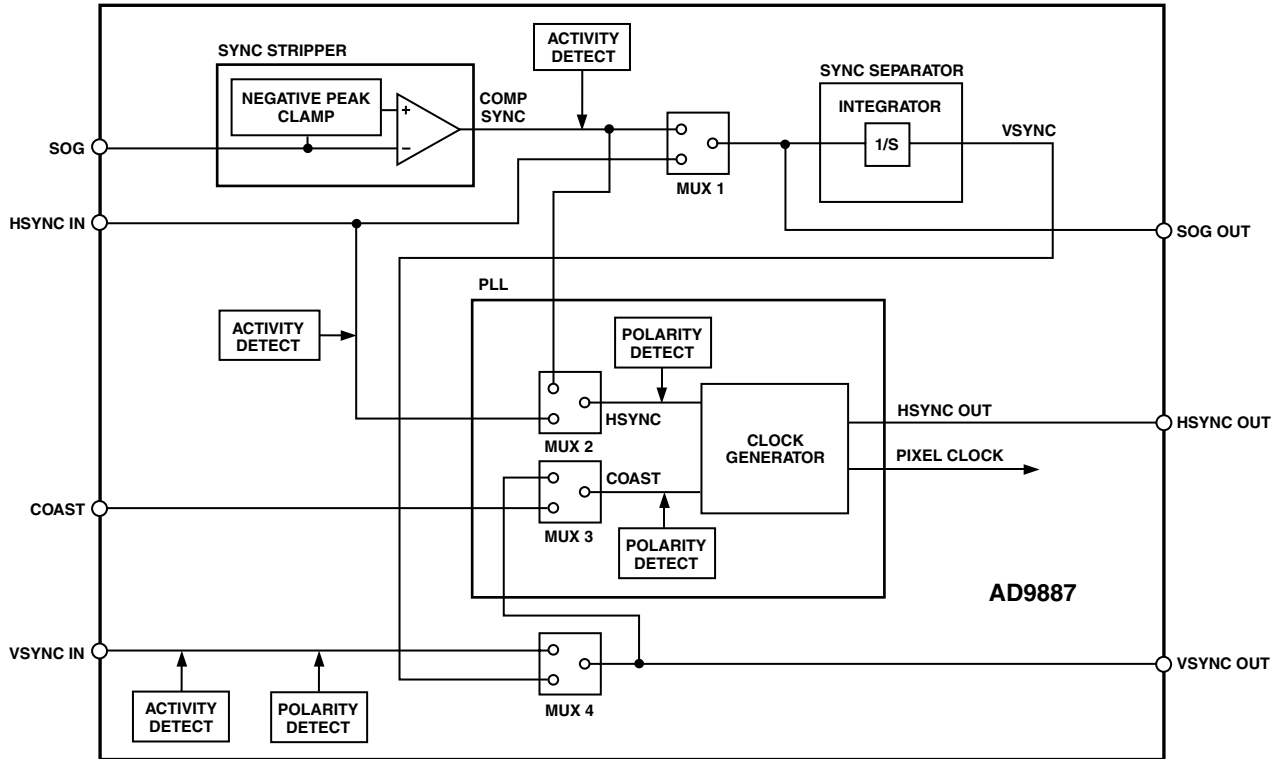

Figure 38. Sync Processing Block Diagram

### PCB LAYOUT RECOMMENDATIONS

The AD9887 is a high-performance, high-speed analog device. As such, to get the maximum performance out of the part it is important to have a well laid-out board. The following is a guide for designing a board using the AD9887.

#### Analog Interface Inputs

Using the following layout techniques on the graphics inputs is extremely important:

Minimize the trace length running into the graphics inputs. This is accomplished by placing the AD9887 as close as possible to the graphics VGA connector. Long input trace lengths are undesirable because they will pick up more noise from the board and other external sources.

Place the 75  $\Omega$  termination resistors as close to the AD9887 chip as possible. Any additional trace length between the termination resistors and the input of the AD9887 increases the magnitude of reflections, which will corrupt the graphics signal.

Use 75  $\Omega$  matched impedance traces. Trace impedances other than 75  $\Omega$  will also increase the chance of reflections.

The AD9887 has very high input bandwidth, (330 MHz). While this is desirable for acquiring a high resolution PC graphics signal with fast edges, it means that it will also capture any high frequency noise present. Therefore, it is important to reduce the amount of noise that gets coupled to the inputs. Avoid running any digital traces near the analog inputs.

Due to the high bandwidth of the AD9887, sometimes low-pass filtering the analog inputs can help to reduce noise. (For many applications, filtering is unnecessary.) Experiments have shown

that placing a series ferrite bead prior to the 75  $\Omega$  termination resistor is helpful in filtering out excess noise. Specifically, the part used was the # 2508051217Z0 from Fair-Rite, but each application may work best with a different bead value. Alternately, placing a 100  $\Omega$  to 120  $\Omega$  resistor between the 75  $\Omega$  termination resistor and the input coupling capacitor can also be beneficial.

#### Digital Interface Inputs

Each differential input pair ( $R_{XO+}$ ,  $R_{XO-}$ ,  $R_{XC+}$ ,  $R_{XC-}$ , etc.) should be routed together using 50  $\Omega$  strip line routing techniques and should be kept as short as possible. No other components should be placed on these inputs; for example, no clamping diodes. Every effort should also be made to route these signals on a single layer (component layer) with no vias.

#### Power Supply Bypassing

It is recommended to bypass each power supply pin with a 0.1  $\mu\text{F}$  capacitor. The exception is in the case where two or more supply pins are adjacent to each other. For these groupings of powers/grounds, it is only necessary to have one bypass capacitor. The fundamental idea is to have a bypass capacitor within about 0.5 cm of each power pin. Also, avoid placing the capacitor on the opposite side of the PC board from the AD9887, as that interposes resistive vias in the path.

The bypass capacitors should be physically located between the power plane and the power pin. Current should flow from the power plane to the capacitor to the power pin. Do not make the power connection between the capacitor and the power pin. Placing a via underneath the capacitor pads, down to the power plane, is generally the best approach.

It is particularly important to maintain low noise and good stability of  $PV_D$  (the clock generator supply). Abrupt changes in  $PV_D$  can result in similarly abrupt changes in sampling clock phase and frequency. This can be avoided by careful attention to regulation, filtering, and bypassing. It is highly desirable to provide separate regulated supplies for each of the analog circuitry groups ( $V_D$  and  $PVD$ ).

Some graphic controllers use substantially different levels of power when active (during active picture time) and when idle (during horizontal and vertical sync periods). This can result in a measurable change in the voltage supplied to the analog supply regulator, which can in turn produce changes in the regulated analog supply voltage. This can be mitigated by regulating the analog supply, or at least  $PV_D$ , from a different, cleaner power source (for example, from a 12 V supply).

It is also recommended to use a single ground plane for the entire board. Experience has repeatedly shown that the noise performance is the same or better with a single ground plane. Using multiple ground planes can be detrimental because each separate ground plane is smaller, and long ground loops can result.

In some cases, using separate ground planes is unavoidable. For those cases, it is recommended to at least place a single ground plane under the AD9887. The location of the split should be at the receiver of the digital outputs. For this case it is even more important to place components wisely because the current loops will be much longer (current takes the path of least resistance). An example of a current loop:

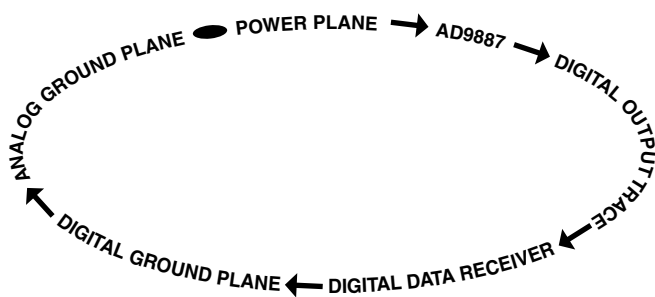

Figure 39. Example of a Current Loop

#### PLL

Place the PLL loop filter components as close to the FILT pin as possible.

Do not place any digital or other high-frequency traces near these components.

Use the values suggested in the data sheet with 10% tolerances or less.

#### Outputs (Both Data and Clocks)

Try to minimize the trace length that the digital outputs have to drive. Longer traces have higher capacitance, which require more current that causes more internal digital noise.

Shorter traces reduce the possibility of reflections.

Adding a series resistor of value 50  $\Omega$ –200  $\Omega$  can suppress reflections, reduce EMI, and reduce the current spikes inside of the AD9887. If series resistors are used, place them as close to the AD9887 pins as possible (try not to add vias or extra length to the output trace in order to get the resistors closer).

If possible, limit the capacitance that each of the digital outputs drives to less than 10 pF. This can easily be accomplished by keeping traces short and by connecting the outputs to only one device. Loading the outputs with excessive capacitance will increase the current transients inside of the AD9887 creating more digital noise on its power supplies.

#### Digital Inputs

The digital inputs on the AD9887 were designed to work with 3.3 V signals.

Any noise that gets onto the Hsync input trace will add jitter to the system. Therefore, minimize the trace length and do not run any digital or other high-frequency traces near it.

#### Voltage Reference

Bypass with a 0.1  $\mu$ F capacitor. Place as close to the AD9887 pin as possible. Make the ground connection as short as possible.

REFOUT is easily connected to REFIN with a short trace. Avoid making this trace any longer than it needs to be.

When using an external reference, the REFOUT output, while unused, still needs to be bypassed with a 0.1  $\mu$ F capacitor in order to avoid ringing.

**OUTLINE DIMENSIONS**

Dimensions shown in inches and (mm).

**160-Lead MQFP  
(S-160)**

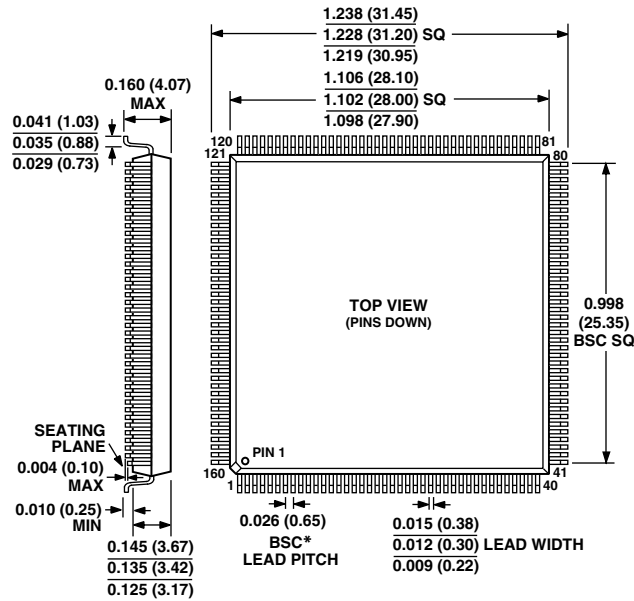

\*THE ACTUAL POSITION OF EACH LEAD IS WITHIN 0.0047 (0.12) FROM ITS IDEAL POSITION WHEN MEASURED IN THE LATERAL DIRECTION. CENTER FIGURES ARE TYPICAL UNLESS OTHERWISE NOTED. CONTROLLING DIMENSIONS ARE IN MILLIMETERS. INCH DIMENSIONS ARE ROUNDED-OFF MILLIMETER EQUIVALENTS FOR REFERENCE ONLY AND ARE NOT APPROPRIATE FOR USE IN DESIGN.



LittleDiode supplies new, hard to find or obsolete electronic components and semiconductors all over the world.

With over two million different components listed you are sure to find the part you need.

Feel free to visit us today at our online store:

[LittleDiode.com](http://LittleDiode.com)

Looking forward to providing you with the best possible service.