

# ADC12130/ADC12132/ADC12138

## Self-Calibrating 12-Bit Plus Sign Serial I/O A/D Converters with MUX and Sample/Hold

### General Description

The ADC12130, ADC12132 and ADC12138 are 12-bit plus sign successive approximation A/D converters with serial I/O and configurable input multiplexer. The ADC12132 and ADC12138 have a 2 and an 8 channel multiplexer, respectively. The differential multiplexer outputs and A/D inputs are available on the MUXOUT1, MUXOUT2, A/DIN1 and A/DIN2 pins. The ADC12130 has a two channel multiplexer with the multiplexer outputs and A/D inputs internally connected. The ADC12130 family is tested with a 5 MHz clock. On request, these A/Ds go through a self calibration process that adjusts linearity, zero and full-scale errors to typically less than  $\pm 1$  LSB each.

The analog inputs can be configured to operate in various combinations of single-ended, differential, or pseudo-differential modes. A fully differential unipolar analog input range (0V to +5V) can be accommodated with a single +5V supply. In the differential modes, valid outputs are obtained even when the negative inputs are greater than the positive because of the 12-bit plus sign output data format.

The serial I/O is configured to comply with the NSC MICROWIRE™. For voltage references, see the LM4040 or LM4041.

### Features

- Serial I/O (MICROWIRE, SPI and QSPI Compatible)
- 2 or 8 channel differential or single-ended multiplexer
- Analog input sample/hold function
- Power down mode
- Programmable acquisition time
- Variable digital output word length and format
- No zero or full scale adjustment required
- 0V to 5V analog input range with single 5V power supply

### Key Specifications

- Resolution: 12-bit plus sign
- 12-bit plus sign conversion time: 8.8  $\mu$ s (max)
- 12-bit plus sign throughput time: 14  $\mu$ s (max)
- Integral linearity error:  $\pm 2$  LSB (max)
- Single supply: 3.3V or 5V  $\pm 10\%$
- Power consumption
 

|                   |                   |
|-------------------|-------------------|
| — 3.3V            | 15 mW (max)       |
| — 3.3V power down | 40 $\mu$ W (typ)  |
| — 5V              | 33 mW (max)       |
| — 5V power down   | 100 $\mu$ W (typ) |

### Applications

- Pen-based computers
- Digitizers
- Global positioning systems

## ADC12138 Simplified Block Diagram

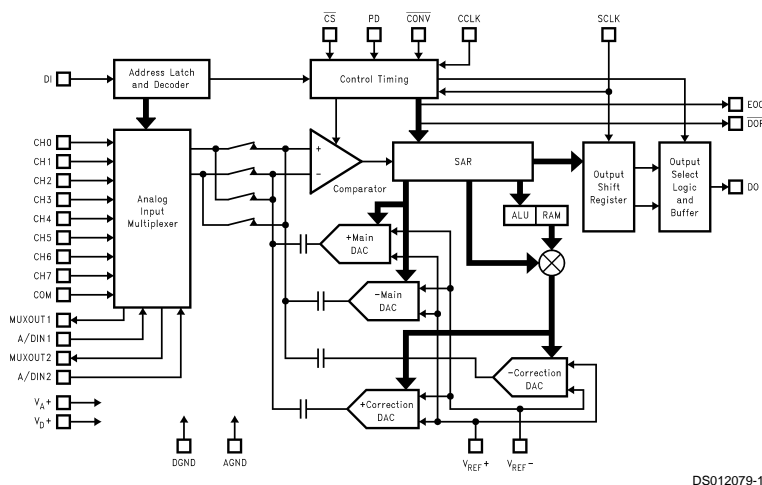

DS012079-1

## Ordering Information

| Industrial Temperature Range<br>$-40^{\circ}\text{C} \leq T_A \leq +85^{\circ}\text{C}$ | NS Package Number  |
|---|--------------------|
| ADC12130CIN   | N16E, Dual-In-Line |
| ADC12130CIWM  | M16B, Wide Body SO |
| ADC12132CIMSA   | MSA20, SSOP        |
| ADC12138CIN   | N28B, Dual-In-Line |
| ADC12138CIWM  | M28B               |
| ADC12138CIMSA   | MSA28, SSOP        |

## Connection Diagrams

16-Pin Dual-In-Line and Wide Body SO Packages

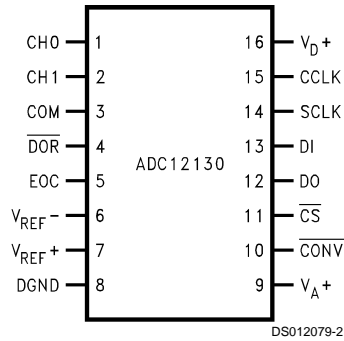

Top View

20-Pin SSOP Package

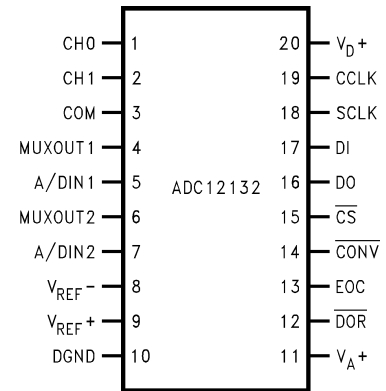

Top View

28-Pin Dual-In-Line, SSOP and Wide Body SO Packages

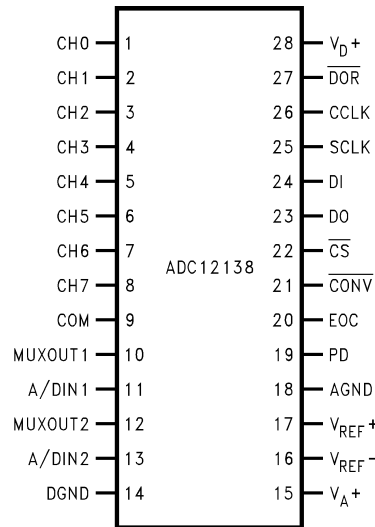

Top View

## Pin Descriptions

|                 |  |  |
|-----------------|--|--|
| CCLK            | The clock applied to this input controls the successive approximation conversion time interval and the acquisition time. The rise and fall times of the clock edges should not exceed 1 $\mu$ s.   |  |
| SCLK            | This is the serial data clock input. The clock applied to this input controls the rate at which the serial data exchange occurs. The rising edge loads the information on the DI pin into the multiplexer address and mode select shift register. This address controls which channel of the analog input multiplexer (MUX) is selected and the mode of operation for the A/D. With $\overline{CS}$ low, the falling edge of SCLK shifts the data resulting from the previous ADC conversion out on DO, with the exception of the first bit of data. When $\overline{CS}$ is low continuously, the first bit of the data is clocked out on the rising edge of EOC (end of conversion). When $\overline{CS}$ is toggled, the falling edge of $\overline{CS}$ always clocks out the first bit of data. $\overline{CS}$ should be brought low when SCLK is low. The rise and fall times of the clock edges should not exceed 1 $\mu$ s.   |  |
| DI              | This is the serial data input pin. The data applied to this pin is shifted by the rising edge of SCLK into the multiplexer address and mode select register. <i>Table 2</i> through <i>Table 4</i> show the assignment of the multiplexer address and the mode select data.  |  |
| DO              | The data output pin. This pin is an active push/pull output when $\overline{CS}$ is low. When $\overline{CS}$ is high, this output is TRI-STATE. The A/D conversion result (DB0–DB12) and converter status data are clocked out by the falling edge of SCLK on this pin. The word length and format of this result can vary (see <i>Table 1</i> ). The word length and format are controlled by the data shifted into the multiplexer address and mode select register (see <i>Table 4</i> ).  |  |
| EOC             | This pin is an active push/pull output and indicates the status of the ADC12130/2/8. When low, it signals that the A/D is busy with a conversion, auto-calibration, auto-zero or power down cycle. The rising edge of EOC signals the end of one of these cycles.  |  |
| $\overline{CS}$ | This is the chip select pin. When a logic low is applied to this pin, the rising edge of SCLK shifts the data on DI into the address register. This low also brings DO out of TRI-STATE. With $\overline{CS}$ low, the falling edge of SCLK shifts the data resulting from the previous ADC conversion out on DO, with the exception of the first bit of data. When $\overline{CS}$ is low continuously, the first bit of the data is clocked out on the rising edge of EOC (end of conversion). When $\overline{CS}$ is toggled, the falling edge of $\overline{CS}$ always clocks out the first bit of data. $\overline{CS}$ should be brought low when SCLK is low. The falling edge of $\overline{CS}$ resets a conversion in progress and starts the sequence for a new conversion. When $\overline{CS}$ is brought back low during a conversion, that conversion is prematurely terminated. The data in the output latches may be corrupted. Therefore, when $\overline{CS}$ is brought back | <p>low during a conversion in progress the data output at that time should be ignored. <math>\overline{CS}</math> may also be left continuously low. In this case it is imperative that the correct number of SCLK pulses be applied to the ADC in order to remain synchronous. After the ADC supply power is applied it expects to see 13 clock pulses for each I/O sequence. The number of clock pulses the ADC expects is the same as the digital output word length. This word length can be modified by the data shifted in on the DO pin. <i>Table 4</i> details the data required.</p> <p><math>\overline{DOR}</math> This is the data output ready pin. This pin is an active push/pull output. It is low when the conversion result is being shifted out and goes high to signal that all the data has been shifted out.</p> <p><math>\overline{CONV}</math> A logic low is required on this pin to program any mode or change the ADC's configuration as listed in the Mode Programming Table (<i>Table 4</i>) such as 12-bit conversion, Auto Cal, Auto Zero etc. When this pin is high the ADC is placed in the read data only mode. While in the read data only mode, bringing <math>\overline{CS}</math> low and pulsing SCLK will only clock out on DO any data stored in the ADCs output shift register. The data on DI will be neglected. A new conversion will not be started and the ADC will remain in the mode and/or configuration previously programmed. Read data only cannot be performed while a conversion, Auto-Cal or Auto-Zero are in progress.</p> <p>PD This is the power down pin. When PD is high the A/D is powered down; when PD is low the A/D is powered up. The A/D takes a maximum of 700 <math>\mu</math>s to power up after the command is given.</p> <p>CH0–CH7 These are the analog inputs of the MUX. A channel input is selected by the address information at the DI pin, which is loaded on the rising edge of SCLK into the address register (see <i>Table 2</i> and <i>Table 3</i>).<br/>The voltage applied to these inputs should not exceed <math>V_{A+}</math> or go below GND. Exceeding this range on an unselected channel will corrupt the reading of a selected channel.</p> <p>COM This pin is another analog input pin. It is used as a pseudo ground when the analog multiplexer is single-ended.</p> <p>MUXOUT1, MUXOUT2 These are the multiplexer output pins.</p> <p>A/DIN1, A/DIN2 These are the converter input pins. MUXOUT1 is usually tied to A/DIN1. MUXOUT2 is usually tied to A/DIN2. If external circuitry is placed between MUXOUT1 and A/DIN1, or MUXOUT2 and A/DIN2 it may be necessary to protect these pins. The voltage at these pins should not exceed <math>V_{A+}</math> or go below AGND (see <i>Figure 5</i>).</p> <p><math>V_{REF+}</math> This is the positive analog voltage reference input. In order to maintain accuracy, the voltage range of <math>V_{REF}</math> (<math>V_{REF} = V_{REF+} - V_{REF-}</math>) is</p> |

## Pin Descriptions (Continued)

|            |  |                     |  |
|------------|--|---------------------|--|
|            | <p>1 <math>V_{DC}</math> to 5.0 <math>V_{DC}</math> and the voltage at <math>V_{REF+}</math> cannot exceed <math>V_{A+}</math>. See <i>Figure 6</i> for recommended bypassing.</p> | $V_{A+}$ , $V_{D+}$ | <p>These are the analog and digital power supply pins. <math>V_{A+}</math> and <math>V_{D+}</math> are not connected together on the chip. These pins should be tied to the same power supply and bypassed separately (see <i>Figure 6</i>). The operating voltage range of <math>V_{A+}</math> and <math>V_{D+}</math> is 3.0 <math>V_{DC}</math> to 5.5 <math>V_{DC}</math>.</p> |
| $V_{REF-}$ | <p>The negative voltage reference input. In order to maintain accuracy, the voltage at this pin must not go below GND or exceed <math>V_{A+}</math>. (See <i>Figure 6</i>).</p>    | DGND                | <p>This is the digital ground pin (see <i>Figure 6</i>).</p>   |
|            |  | AGND                | <p>This is the analog ground pin (see <i>Figure 6</i>).</p>  |

## Absolute Maximum Ratings (Notes 1, 2)

If Military/Aerospace specified devices are required, please contact the National Semiconductor Sales Office/Distributors for availability and specifications.

|   |                       |
|---|-----------------------|
| Positive Supply Voltage<br>( $V^+ = V_{A^+} = V_{D^+}$ )    | 6.5V                  |
| Voltage at Inputs and Outputs<br>except CH0–CH7 and COM     | –0.3V to $V^+ + 0.3V$ |
| Voltage at Analog Inputs<br>CH0–CH7 and COM                 | GND –5V to $V^+ + 5V$ |
| $ V_{A^+} - V_{D^+} $                                       | 300 mV                |
| Input Current at Any Pin (Note 3)                           | ±30 mA                |
| Package Input Current (Note 3)                              | ±120 mA               |
| Package Dissipation at<br>$T_A = 25^\circ\text{C}$ (Note 4) | 500 mW                |
| ESD Susceptibility (Note 5)                                 |                       |
| Human Body Model  | 1500V                 |
| Soldering Information                                       |                       |
| N Packages (10 seconds)                                     | 260°C                 |
| SO Package (Note 6):  |                       |
| Vapor Phase (60 seconds)                                    | 215°C                 |
| Infrared (15 seconds)                                       | 220°C                 |

Storage Temperature –65°C to +150°C

## Operating Ratings (Notes 1, 2)

|   |   |
|---|---|
| Operating Temperature Range   | $T_{\text{MIN}} \leq T_A \leq T_{\text{MAX}}$ |
| ADC12130CIN, ADC12130CIWM,<br>ADC12132CIMSA,<br>ADC12138CIMSA,<br>ADC12138CIN, ADC12138CIWM | –40°C ≤ $T_A$ ≤ +85°C                         |
| Supply Voltage ( $V^+ = V_{A^+} = V_{D^+}$ )  | +3.0V to +5.5V                                |
| $ V_{A^+} - V_{D^+} $   | ≤ 100 mV                                      |
| $V_{\text{REF}^+}$  | 0V to $V_{A^+}$                               |
| $V_{\text{REF}^-}$  | 0V to $V_{\text{REF}^+}$                      |
| $V_{\text{REF}} (V_{\text{REF}^+} - V_{\text{REF}^-})$                                      | 1V to $V_{A^+}$                               |
| $V_{\text{REF}}$ Common Mode Voltage Range  |   |
| $\frac{(V_{\text{REF}^+} + V_{\text{REF}^-})}{2}$   | 0.1 $V_{A^+}$ to 0.6 $V_{A^+}$                |
| A/DIN1, A/DIN2, MUXOUT1<br>and MUXOUT2 Voltage Range  | 0V to $V_{A^+}$                               |
| A/D IN Common Mode Voltage<br>Range   |   |
| $\frac{(V_{\text{IN}^+} + V_{\text{IN}^-})}{2}$   | 0V to $V_{A^+}$                               |

## Converter Electrical Characteristics

The following specifications apply for ( $V^+ = V_{A^+} = V_{D^+} = +5V$ ,  $V_{\text{REF}^+} = +4.096V$ , and fully differential input with fixed 2.048V common-mode voltage) or ( $V^+ = V_{A^+} = V_{D^+} = 3.3V$ ,  $V_{\text{REF}^+} = 2.5V$  and fully-differential input with fixed 1.250V common-mode voltage),  $V_{\text{REF}^-} = 0V$ , 12-bit + sign conversion mode, source impedance for analog inputs,  $V_{\text{REF}^-}$  and  $V_{\text{REF}^+} \leq 25\Omega$ ,  $f_{\text{CK}} = f_{\text{SK}} = 5\text{ MHz}$ , and 10 ( $t_{\text{CK}}$ ) acquisition time unless otherwise specified. **Boldface limits apply for  $T_A = T_J = T_{\text{MIN}}$  to  $T_{\text{MAX}}$** ; all other limits  $T_A = T_J = 25^\circ\text{C}$ . (Notes 7, 8, 9)

| Symbol                                  | Parameter                         | Conditions   | Typical<br>(Note 10) | Limits<br>(Note 11) | Units<br>(Limits) |
|---|-----------------------------------|--|----------------------|---------------------|-------------------|
| <b>STATIC CONVERTER CHARACTERISTICS</b> |                                   |  |                      |                     |                   |
|   | Resolution                        |  |                      | <b>12 + sign</b>    | Bits (min)        |
| +ILE                                    | Positive Integral Linearity Error | After Auto-Cal (Notes 12, 18)  | ±1/2                 | <b>±2</b>           | LSB (max)         |
| –ILE                                    | Negative Integral Linearity Error | After Auto-Cal (Notes 12, 18)  | ±1/2                 | <b>±2</b>           | LSB (max)         |
| DNL                                     | Differential Non-Linearity        | After Auto-Cal   |                      | <b>±1.5</b>         | LSB (max)         |
|   | Positive Full-Scale Error         | After Auto-Cal (Notes 12, 18)  | ±1/2                 | <b>±3.0</b>         | LSB (max)         |
|   | Negative Full-Scale Error         | After Auto-Cal (Notes 12, 18)  | ±1/2                 | <b>±3.0</b>         | LSB (max)         |
|   | Offset Error                      | After Auto-Cal (Notes 5, 18)<br>$V_{\text{IN}(+)} = V_{\text{IN}(-)} = 2.048V$ | ±1/2                 | <b>±2</b>           | LSB (max)         |
|   | DC Common Mode Error              | After Auto-Cal (Note 15)   | ±2                   |                     | LSB (max)         |
| TUE                                     | Total Unadjusted Error            | After Auto-Cal<br>(Notes 12, 13, 14)   | ±1                   |                     | LSB               |

## Converter Electrical Characteristics

The following specifications apply for ( $V^+ = V_{A+} = V_{D+} = +5V$ ,  $V_{REF+} = +4.096V$ , and fully differential input with fixed 2.048V common-mode voltage) or ( $V^+ = V_{A+} = V_{D+} = +3.3V$ ,  $V_{REF+} = +2.5V$  and fully-differential input with fixed 1.250V common-mode voltage),  $V_{REF-} = 0V$ , 12-bit + sign conversion mode, source impedance for analog inputs,  $V_{REF-}$  and  $V_{REF+} \leq 25\Omega$ ,  $f_{CK} = f_{SK} = 5$  MHz, and 10 ( $t_{CK}$ ) acquisition time unless otherwise specified. **Boldface limits apply for  $T_A = T_J = T_{MIN}$  to  $T_{MAX}$** ; all other limits  $T_A = T_J = 25^\circ C$ . (Notes 7, 8, 9) (Continued)

| Symbol  | Parameter                               | Conditions   | Typical<br>(Note 10) | Limits<br>(Note 11) | Units<br>(Limits) |
|---|---|--|----------------------|---------------------|-------------------|
| <b>STATIC CONVERTER CHARACTERISTICS (Continued)</b>   |   |  |                      |                     |                   |
|   | Multiplexer Channel to Channel Matching |  | $\pm 0.05$           |                     | LSB               |
|   | Power Supply Sensitivity                | $V^+ = +5V \pm 10\%$<br>$V_{REF} = +4.096V$                |                      |                     |                   |
|   | Offset Error                            |  | $\pm 0.5$            |                     | LSB               |
|   | + Full-Scale Error                      |  | $\pm 0.5$            |                     | LSB               |
|   | - Full-Scale Error                      |  | $\pm 0.5$            |                     | LSB               |
|   | + Integral Linearity Error              |  | $\pm 0.5$            |                     | LSB               |
|   | - Integral Linearity Error              |  | $\pm 0.5$            |                     | LSB               |
| <b>UNIPOLAR DYNAMIC CONVERTER CHARACTERISTICS</b>     |   |  |                      |                     |                   |
| S/(N+D)   | Signal-to-Noise Plus Distortion Ratio   | $f_{IN} = 1$ kHz, $V_{IN} = 5 V_{PP}$ , $V_{REF+} = 5.0V$  | 69.4                 |                     | dB                |
|   |   | $f_{IN} = 20$ kHz, $V_{IN} = 5 V_{PP}$ , $V_{REF+} = 5.0V$ | 68.3                 |                     | dB                |
|   |   | $f_{IN} = 40$ kHz, $V_{IN} = 5 V_{PP}$ , $V_{REF+} = 5.0V$ | 65.7                 |                     | dB                |
|   | -3 dB Full Power Bandwidth              | $V_{IN} = 5 V_{PP}$ , where S/(N+D) drops 3 dB             | 31                   |                     | kHz               |
| <b>DIFFERENTIAL DYNAMIC CONVERTER CHARACTERISTICS</b> |   |  |                      |                     |                   |
| S/(N+D)   | Signal-to-Noise Plus Distortion Ratio   | $f_{IN} = 1$ kHz, $V_{IN} = \pm 5V$ , $V_{REF+} = 5.0V$    | 77.0                 |                     | dB                |
|   |   | $f_{IN} = 20$ kHz, $V_{IN} = \pm 5V$ , $V_{REF+} = 5.0V$   | 73.9                 |                     | dB                |
|   |   | $f_{IN} = 40$ kHz, $V_{IN} = \pm 5V$ , $V_{REF+} = 5.0V$   | 67.0                 |                     | dB                |
|   | -3 dB Full Power Bandwidth              | $V_{IN} = \pm 5V$ , where S/(N+D) drops 3 dB               | 40                   |                     | kHz               |

## Electrical Characteristics

The following specifications apply for ( $V^+ = V_{A+} = V_{D+} = +5V$ ,  $V_{REF+} = +4.096V$ , and fully differential input with fixed 2.048V common-mode voltage) or ( $V^+ = V_{A+} = V_{D+} = +3.3V$ ,  $V_{REF+} = 2.5V$  and fully-differential input with fixed 1.250V common-mode voltage),  $V_{REF-} = 0V$ , 12-bit + sign conversion mode, source impedance for analog inputs,  $V_{REF-}$  and  $V_{REF+} \leq 25\Omega$ ,  $f_{CK} = f_{SK} = 5$  MHz, and 10 ( $t_{CK}$ ) acquisition time unless otherwise specified. **Boldface limits apply for  $T_A = T_J = T_{MIN}$  to  $T_{MAX}$** ; all other limits  $T_A = T_J = 25^\circ C$ . (Notes 7, 8, 9)

| Symbol  | Parameter   | Conditions                              | Typical<br>(Note 10)                                   | Limits<br>(Note 11) | Units<br>(Limits) |
|---|---|---|--|---------------------|-------------------|
| <b>REFERENCE INPUT, ANALOG INPUTS AND MULTIPLEXER CHARACTERISTICS</b> |   |   |  |                     |                   |
| $C_{REF}$   | Reference Input Capacitance                           |   | 85   |                     | pF                |
| $C_{A/D}$   | A/DIN1 and A/DIN2 Analog Input Capacitance            |   | 75   |                     | pF                |
|   | A/DIN1 and A/DIN2 Analog Input Leakage Current        | $V_{IN} = +5.0V$ or<br>$V_{IN} = 0V$    | $\pm 0.1$  |                     | $\mu A$           |
|   | CH0-CH7 and COM Input Voltage                         |   | <b>GND - 0.05</b><br><b><math>V_{A+} + 0.05</math></b> |                     | V                 |
| $C_{CH}$  | CH0-CH7 and COM Input Capacitance                     |   | 10   |                     | pF                |
| $C_{MUXOUT}$  | MUX Output Capacitance                                |   | 20   |                     | pF                |
|   | Off Channel Leakage (Note 16)<br>CH0-CH7 and COM Pins | On Channel = 5V and<br>Off Channel = 0V | -0.01  |                     | $\mu A$           |
|   |   | On Channel = 0V and<br>Off Channel = 5V | 0.01   |                     | $\mu A$           |

## Electrical Characteristics (Continued)

The following specifications apply for ( $V^+ = V_{A+} = V_{D+} = +5V$ ,  $V_{REF+} = +4.096V$ , and fully differential input with fixed 2.048V common-mode voltage) or ( $V^+ = V_{A+} = V_{D+} = +3.3V$ ,  $V_{REF+} = 2.5V$  and fully-differential input with fixed 1.250V common-mode voltage),  $V_{REF-} = 0V$ , 12-bit + sign conversion mode, source impedance for analog inputs,  $V_{REF-}$  and  $V_{REF+} \leq 25\Omega$ ,  $f_{CK} = f_{SK} = 5$  MHz, and 10 ( $t_{CK}$ ) acquisition time unless otherwise specified. **Boldface limits apply for  $T_A = T_J = T_{MIN}$  to  $T_{MAX}$** ; all other limits  $T_A = T_J = 25^\circ C$ . (Notes 7, 8, 9)

| Symbol  | Parameter  | Conditions                                  | Typical<br>(Note 10) | Limits<br>(Note 11) | Units<br>(Limits) |
|---|--|---|----------------------|---------------------|-------------------|
| <b>REFERENCE INPUT, ANALOG INPUTS AND MULTIPLEXER CHARACTERISTICS</b> |  |   |                      |                     |                   |
|   | On Channel Leakage (Note 16)<br>CH0–CH7 and COM Pins | On Channel = 5V and<br>Off Channel = 0V     | 0.01                 |                     | $\mu A$           |
|   |  | On Channel = 0V and<br>Off Channel = 5V     | -0.01                |                     | $\mu A$           |
|   | MUXOUT1 and MUXOUT2<br>Leakage Current               | $V_{MUXOUT} = 5.0V$ or<br>$V_{MUXOUT} = 0V$ | 0.01                 |                     | $\mu A$           |
| $R_{ON}$  | MUX On Resistance                                    | $V_{IN} = 2.5V$ and<br>$V_{MUXOUT} = 2.4V$  | 850                  | <b>1900</b>         | $\Omega$ (max)    |
|   | $R_{ON}$ Matching Channel to Channel                 | $V_{IN} = 2.5V$ and<br>$V_{MUXOUT} = 2.4V$  | 5                    |                     | %                 |
|   | Channel to Channel Crosstalk                         | $V_{IN} = 5 V_{PP}$ , $f_{IN} = 40$ kHz     | -72                  |                     | dB                |
|   | MUX Bandwidth  |   | 90                   |                     | kHz               |

## DC and Logic Electrical Characteristics

The following specifications apply for ( $V^+ = V_{A+} = V_{D+} = +5V$ ,  $V_{REF+} = +4.096V$ , and fully-differential input with fixed 2.048V common-mode voltage) or ( $V^+ = V_{A+} = V_{D+} = +3.3V$ ,  $V_{REF+} = +2.5V$  and fully-differential input with fixed 1.250V common-mode voltage),  $V_{REF-} = 0V$ , 12-bit + sign conversion mode, source impedance for analog inputs,  $V_{REF-}$  and  $V_{REF+} \leq 25\Omega$ ,  $f_{CK} = f_{SK} = 5$  MHz, and 10 ( $t_{CK}$ ) acquisition time unless otherwise specified. **Boldface limits apply for  $T_A = T_J = T_{MIN}$  to  $T_{MAX}$** ; all other limits  $T_A = T_J = 25^\circ C$ . (Notes 7, 8, 9)

| Symbol | Parameter | Conditions | Typical<br>(Note 10) | $V^+ = V_{A+} =$<br>$V_{D+} = 3.3V$ | $V^+ = V_{A+} =$<br>$V_{D+} = 5V$ | Units<br>(Limits) |
|--------|-----------|------------|----------------------|-------------------------------------|-----------------------------------|-------------------|
|        |           |            |                      | Limits<br>(Note 11)                 | Limits<br>(Note 11)               |                   |

### CCLK, CS, CONV, DI, PD AND SCLK INPUT CHARACTERISTICS

|             |                           |                                |        |             |             |               |
|-------------|---------------------------|--------------------------------|--------|-------------|-------------|---------------|
| $V_{IN(1)}$ | Logical "1" Input Voltage | $V_{A+} = V_{D+} = V^+ + 10\%$ |        | <b>2.0</b>  | <b>2.0</b>  | V (min)       |
| $V_{IN(0)}$ | Logical "0" Input Voltage | $V_{A+} = V_{D+} = V^+ - 10\%$ |        | <b>0.8</b>  | <b>0.8</b>  | V (max)       |
| $I_{IN(1)}$ | Logical "1" Input Current | $V_{IN} = V^+$                 | 0.005  | <b>1.0</b>  | <b>1.0</b>  | $\mu A$ (max) |
| $I_{IN(0)}$ | Logical "0" Input Current | $V_{IN} = 0V$                  | -0.005 | <b>-1.0</b> | <b>-1.0</b> | $\mu A$ (min) |

### DO, EOC AND DOR DIGITAL OUTPUT CHARACTERISTICS

|              |                                     |  |      |             |             |               |
|--------------|-------------------------------------|--|------|-------------|-------------|---------------|
| $V_{OUT(1)}$ | Logical "1" Output Voltage          | $V_{A+} = V_{D+} = V^+ - 10\%$ ,<br>$I_{OUT} = -360 \mu A$ |      | <b>2.4</b>  | <b>2.4</b>  | V (min)       |
|              |                                     | $V_{A+} = V_{D+} = V^+ - 10\%$ ,<br>$I_{OUT} = -10 \mu A$  |      | <b>2.9</b>  | <b>4.25</b> | V (min)       |
| $V_{OUT(0)}$ | Logical "0" Output Voltage          | $V_{A+} = V_{D+} = V^+ - 10\%$<br>$I_{OUT} = 1.6$ mA       |      | <b>0.4</b>  | <b>0.4</b>  | V (max)       |
| $I_{OUT}$    | TRI-STATE Output Current            | $V_{OUT} = 0V$   | -0.1 | <b>-3.0</b> | <b>-3.0</b> | $\mu A$ (max) |
|              |                                     | $V_{OUT} = V^+$  | -0.1 | <b>3.0</b>  | <b>3.0</b>  |               |
| $+I_{SC}$    | Output Short Circuit Source Current | $V_{OUT} = 0V$   | -14  |             |             | mA            |

## DC and Logic Electrical Characteristics (Continued)

The following specifications apply for ( $V^+ = V_{A^+} = V_{D^+} = +5V$ ,  $V_{REF^+} = +4.096V$ , and fully-differential input with fixed 2.048V common-mode voltage) or ( $V^+ = V_{A^+} = V_{D^+} = +3.3V$ ,  $V_{REF^+} = +2.5V$  and fully-differential input with fixed 1.250V common-mode voltage),  $V_{REF^-} = 0V$ , 12-bit + sign conversion mode, source impedance for analog inputs,  $V_{REF^-}$  and  $V_{REF^+} \leq 25\Omega$ ,  $f_{CK} = f_{SK} = 5$  MHz, and 10 ( $t_{CK}$ ) acquisition time unless otherwise specified. **Boldface limits apply for  $T_A = T_J = T_{MIN}$  to  $T_{MAX}$** ; all other limits  $T_A = T_J = 25^\circ C$ . (Notes 7, 8, 9)

| Symbol  | Parameter                               | Conditions                                      | Typical<br>(Note<br>10) | $V^+ = V_{A^+} =$<br>$V_{D^+} = 3.3V$ | $V^+ = V_{A^+} =$<br>$V_{D^+} = 5V$ | Units<br>(Limits) |
|---|---|---|-------------------------|---------------------------------------|-------------------------------------|-------------------|
|   |   |   |                         | Limits<br>(Note 11)                   | Limits<br>(Note 11)                 |                   |
| <b>DO, EOC AND DOR DIGITAL OUTPUT CHARACTERISTICS</b> |   |   |                         |                                       |                                     |                   |
| $-I_{SC}$   | Output Short<br>Circuit Sink<br>Current | $V_{OUT} = V_{D^+}$                             | 16                      |                                       |                                     | mA                |
| <b>POWER SUPPLY CHARACTERISTICS</b>                   |   |   |                         |                                       |                                     |                   |
| $I_{D^+}$   | Digital Supply<br>Current               | $\overline{CS} = HIGH$ , Powered Down, CCLK on  | 600                     | <b>1.5</b>                            | <b>2.5</b>                          | mA (max)          |
|   |   | $\overline{CS} = HIGH$ , Powered Down, CCLK off | 20                      |                                       |                                     | $\mu A$           |
| $I_{A^+}$   | Positive Analog<br>Supply Current       | $\overline{CS} = HIGH$ , Powered Down, CCLK on  | 10                      | <b>3.0</b>                            | <b>4.0</b>                          | mA (max)          |
|   |   | $\overline{CS} = HIGH$ , Powered Down, CCLK off | 0.1                     |                                       |                                     | $\mu A$           |
| $I_{REF}$   | Reference Input<br>Current              | $\overline{CS} = HIGH$ , Powered Down, CCLK on  | 70                      |                                       |                                     | $\mu A$           |
|   |   | $\overline{CS} = HIGH$ , Powered Down, CCLK off | 0.1                     |                                       |                                     | $\mu A$           |

## AC Electrical Characteristics

The following specifications apply for ( $V^+ = V_{A^+} = V_{D^+} = +5V$ ,  $V_{REF^+} = +4.096V$ , and fully-differential input with fixed 2.048V common-mode voltage) or ( $V^+ = V_{A^+} = V_{D^+} = +3.3V$ ,  $V_{REF^+} = +2.5V$  and fully-differential input with fixed 1.250V common-mode voltage),  $V_{REF^-} = 0V$ , 12-bit + sign conversion mode, source impedance for analog inputs,  $V_{REF^-}$  and  $V_{REF^+} \leq 25\Omega$ ,  $f_{CK} = f_{SK} = 5$  MHz, and 10 ( $t_{CK}$ ) acquisition time unless otherwise specified. **Boldface limits apply for  $T_A = T_J = T_{MIN}$  to  $T_{MAX}$** ; all other limits  $T_A = T_J = 25^\circ C$ . (Note 17)

| Symbol   | Parameter                            | Conditions              | Typical<br>(Note<br>10) | Limits<br>(Note<br>11)         | Units<br>(Limits) |
|----------|--------------------------------------|-------------------------|-------------------------|--------------------------------|-------------------|
| $f_{CK}$ | Conversion Clock<br>(CCLK) Frequency |                         | 10                      | <b>5</b>                       | MHz (max)         |
|          |                                      |                         | 1                       |                                | MHz (min)         |
| $f_{SK}$ | Serial Data Clock<br>SCLK Frequency  |                         | 10                      | <b>5</b>                       | MHz (max)         |
|          |                                      |                         | 0                       |                                | Hz (min)          |
|          | Conversion Clock<br>Duty Cycle       |                         |                         | <b>40</b>                      | % (min)           |
|          |                                      |                         |                         | <b>60</b>                      | % (max)           |
|          | Serial Data Clock<br>Duty Cycle      |                         |                         | <b>40</b>                      | % (min)           |
|          |                                      |                         |                         | <b>60</b>                      | % (max)           |
| $t_C$    | Conversion Time                      | 12-Bit + Sign or 12-Bit | 44( $t_{CK}$ )          | <b>44(<math>t_{CK}</math>)</b> | (max)             |
|          |                                      |                         |                         | <b>8.8</b>                     | $\mu s$ (max)     |

## AC Electrical Characteristics (Continued)

The following specifications apply for ( $V^+ = V_{A+} = V_{D+} = +5V$ ,  $V_{REF+} = +4.096V$ , and fully-differential input with fixed 2.048V common-mode voltage) or ( $V^+ = V_{A+} = V_{D+} = +3.3V$ ,  $V_{REF+} = +2.5V$  and fully-differential input with fixed 1.250V common-mode voltage),  $V_{REF-} = 0V$ , 12-bit + sign conversion mode, source impedance for analog inputs,  $V_{REF-}$  and  $V_{REF+} \leq 25\Omega$ ,  $f_{CK} = f_{SK} = 5$  MHz, and 10 ( $t_{CK}$ ) acquisition time unless otherwise specified. **Boldface limits apply for  $T_A = T_J = T_{MIN}$  to  $T_{MAX}$** ; all other limits  $T_A = T_J = 25^\circ C$ . (Note 17)

| Symbol               | Parameter   | Conditions                     | Typical<br>(Note 10) | Limits<br>(Note 11)              | Units<br>(Limits) |
|----------------------|---|--------------------------------|----------------------|----------------------------------|-------------------|
| $t_A$                | Acquisition Time<br>(Note 19)   | 6 Cycles Programmed            | 6( $t_{CK}$ )        | <b>6(<math>t_{CK}</math>)</b>    | (min)             |
|                      |   |                                |                      | <b>7(<math>t_{CK}</math>)</b>    | (max)             |
|                      |   | 10 Cycles Programmed           | 10( $t_{CK}$ )       | <b>10(<math>t_{CK}</math>)</b>   | (min)             |
|                      |   |                                |                      | <b>11(<math>t_{CK}</math>)</b>   | (max)             |
|                      |   |                                |                      | <b>2.0</b>                       | $\mu s$ (min)     |
|                      |   |                                |                      | <b>2.2</b>                       | $\mu s$ (max)     |
|                      |   | 18 Cycles Programmed           | 18( $t_{CK}$ )       | <b>18(<math>t_{CK}</math>)</b>   | (min)             |
|                      |   |                                |                      | <b>19(<math>t_{CK}</math>)</b>   | (max)             |
|                      |   |                                |                      | <b>3.6</b>                       | $\mu s$ (min)     |
|                      |   |                                |                      | <b>3.8</b>                       | $\mu s$ (max)     |
| 34 Cycles Programmed | 34( $t_{CK}$ )  | <b>34(<math>t_{CK}</math>)</b> | (min)                |                                  |                   |
|                      |   | <b>35(<math>t_{CK}</math>)</b> | (max)                |                                  |                   |
|                      |   | <b>6.8</b>                     | $\mu s$ (min)        |                                  |                   |
|                      |   | <b>7.0</b>                     | $\mu s$ (max)        |                                  |                   |
| $t_{CAL}$            | Self-Calibration Time   |                                | 4944( $t_{CK}$ )     | <b>4944(<math>t_{CK}</math>)</b> | (max)             |
|                      |   |                                |                      | <b>988.8</b>                     | $\mu s$ (max)     |
| $t_{AZ}$             | Auto-Zero Time  |                                | 76( $t_{CK}$ )       | <b>76(<math>t_{CK}</math>)</b>   | (max)             |
|                      |   |                                |                      | <b>15.2</b>                      | $\mu s$ (max)     |
| $t_{SYNC}$           | Self-Calibration or<br>Auto-Zero Synchronization<br>Time from DOR                                     |                                | 2( $t_{CK}$ )        | <b>2(<math>t_{CK}</math>)</b>    | (min)             |
|                      |   |                                |                      | <b>3(<math>t_{CK}</math>)</b>    | (max)             |
| $t_{DOR}$            | DOR High Time when $\overline{CS}$ is Low<br>Continuously for Read Data and Software<br>Power Up/Down |                                | 9( $t_{SK}$ )        | <b>9(<math>t_{SK}</math>)</b>    | (max)             |
|                      |   |                                |                      | <b>1.8</b>                       | $\mu s$ (max)     |
| $t_{CONV}$           | $\overline{CONV}$ Valid Data Time   |                                | 8( $t_{SK}$ )        | <b>8(<math>t_{SK}</math>)</b>    | (max)             |
|                      |   |                                |                      | <b>1.6</b>                       | $\mu s$ (max)     |

## AC Electrical Characteristics

The following specifications apply for ( $V^+ = V_{A+} = V_{D+} = +5V$ ,  $V_{REF+} = +4.096V$ , and fully-differential input with fixed 2.048V common-mode voltage) or ( $V^+ = V_{A+} = V_{D+} = +3.3V$ ,  $V_{REF+} = +2.5V$  and fully-differential input with fixed 1.250V common-mode voltage),  $V_{REF-} = 0V$ , 12-bit + sign conversion mode, source impedance for analog inputs,  $V_{REF-}$  and  $V_{REF+} \leq 25\Omega$ ,  $f_{CK} = f_{SK} = 5$  MHz, and 10 ( $t_{CK}$ ) acquisition time unless otherwise specified. **Boldface limits apply for  $T_A = T_J = T_{MIN}$  to  $T_{MAX}$** ; all other limits  $T_A = T_J = 25^\circ C$ . (Note 17) (Continued)

| Symbol    | Parameter   | Conditions | Typical<br>(Note 10) | Limits<br>(Note 11) | Units<br>(Limits) |
|-----------|---|------------|----------------------|---------------------|-------------------|
| $t_{HPU}$ | Hardware Power-Up Time, Time from<br>PD Falling Edge to EOC Rising Edge                   |            | 500                  | <b>700</b>          | $\mu s$ (max)     |
| $t_{SPU}$ | Software Power-Up Time, Time from<br>Serial Data Clock Falling Edge to<br>EOC Rising Edge |            | 500                  | <b>700</b>          | $\mu s$ (max)     |
| $t_{ACC}$ | Access Time Delay from<br>$\overline{CS}$ Falling Edge to DO Data Valid                   |            | 25                   | <b>60</b>           | ns (max)          |

## AC Electrical Characteristics (Continued)

The following specifications apply for ( $V^+ = V_{A+} = V_{D+} = +5V$ ,  $V_{REF+} = +4.096V$ , and fully-differential input with fixed 2.048V common-mode voltage) or ( $V^+ = V_{A+} = V_{D+} = +3.3V$ ,  $V_{REF+} = +2.5V$  and fully-differential input with fixed 1.250V common-mode voltage),  $V_{REF-} = 0V$ , 12-bit + sign conversion mode, source impedance for analog inputs,  $V_{REF-}$  and  $V_{REF+} \leq 25\Omega$ ,  $f_{CK} = f_{SK} = 5$  MHz, and 10 ( $t_{CK}$ ) acquisition time unless otherwise specified. **Boldface limits apply for  $T_A = T_J = T_{MIN}$  to  $T_{MAX}$** ; all other limits  $T_A = T_J = 25^\circ C$ . (Note 17) (Continued)

| Symbol           | Parameter  | Conditions               | Typical<br>(Note 10) | Limits<br>(Note 11)    | Units<br>(Limits)    |
|------------------|--|--------------------------|----------------------|------------------------|----------------------|
| $t_{SET-UP}$     | Set-Up Time of $\overline{CS}$ Falling Edge to Serial Data Clock Rising Edge |                          |                      | <b>50</b>              | ns (min)             |
| $t_{DELAY}$      | Delay from SCLK Falling Edge to $\overline{CS}$ Falling Edge                 |                          | 0                    | <b>5</b>               | ns (min)             |
| $t_{1H}, t_{0H}$ | Delay from $\overline{CS}$ Rising Edge to DO TRI-STATE®                      | $R_L = 3k, C_L = 100$ pF | 70                   | <b>100</b>             | ns (max)             |
| $t_{HDI}$        | DI Hold Time from Serial Data Clock Rising Edge                              |                          | 5                    | <b>15</b>              | ns (min)             |
| $t_{SDI}$        | DI Set-Up Time from Serial Data Clock Rising Edge                            |                          | 5                    | <b>10</b>              | ns (min)             |
| $t_{HDO}$        | DO Hold Time from Serial Data Clock Falling Edge                             | $R_L = 3k, C_L = 100$ pF | 35                   | <b>65</b><br><b>5</b>  | ns (max)<br>ns (min) |
| $t_{DDO}$        | Delay from Serial Data Clock Falling Edge to DO Data Valid                   |                          | 50                   | <b>90</b>              | ns (max)             |
| $t_{RDO}$        | DO Rise Time, TRI-STATE to High<br>DO Rise Time, Low to High                 | $R_L = 3k, C_L = 100$ pF | 10<br>10             | <b>40</b><br><b>40</b> | ns (max)<br>ns (max) |
| $t_{FDO}$        | DO Fall Time, TRI-STATE to Low<br>DO Fall Time, High to Low                  | $R_L = 3k, C_L = 100$ pF | 15<br>15             | <b>40</b><br><b>40</b> | ns (max)<br>ns (max) |
| $t_{CD}$         | Delay from $\overline{CS}$ Falling Edge to $\overline{DOR}$ Falling Edge     |                          | 45                   | <b>80</b>              | ns (max)             |
| $t_{SD}$         | Delay from Serial Data Clock Falling Edge to $\overline{DOR}$ Rising Edge    |                          | 45                   | <b>80</b>              | ns (max)             |
| $C_{IN}$         | Capacitance of Logic Inputs  |                          | 10                   |                        | pF                   |
| $C_{OUT}$        | Capacitance of Logic Outputs   |                          | 20                   |                        | pF                   |

**Note 1:** Absolute Maximum Ratings indicate limits beyond which damage to the device may occur. Operating Ratings indicate conditions for which the device is functional, but do not guarantee specific performance limits. For guaranteed specifications and test conditions, see the Electrical Characteristics. The guaranteed specifications apply only for the test conditions listed. Some performance characteristics may degrade when the device is not operated under the listed test conditions.

**Note 2:** All voltages are measured with respect to GND, unless otherwise specified.

**Note 3:** When the input voltage ( $V_{IN}$ ) at any pin exceeds the power supplies ( $V_{IN} < GND$  or  $V_{IN} > V_{A+}$  or  $V_{D+}$ ), the current at that pin should be limited to 30 mA. The 120 mA maximum package input current rating limits the number of pins that can safely exceed the power supplies with an input current of 30 mA to four.

**Note 4:** The maximum power dissipation must be derated at elevated temperatures and is dictated by  $T_{Jmax}$ ,  $\theta_{JA}$  and the ambient temperature,  $T_A$ . The maximum allowable power dissipation at any temperature is  $P_D = (T_{Jmax} - T_A)/\theta_{JA}$  or the number given in the Absolute Maximum Ratings, whichever is lower. For this device,  $T_{Jmax} = 150^\circ C$ . The typical thermal resistance ( $\theta_{JA}$ ) of these parts when board mounted follow:

| Part Number   | Thermal Resistance<br>$\theta_{JA}$ |
|---------------|-------------------------------------|
| ADC12130CIN   | 53°C/W                              |
| ADC12130CIWM  | 70°C/W                              |
| ADC12132CIMSA | 134°C/W                             |
| ADC12138CIN   | 40°C/W                              |
| ADC12138CIWM  | 50°C/W                              |
| ADC12138CIMSA | 125°C/W                             |

**Note 5:** The human body model is a 100 pF capacitor discharged through a 1.5 k $\Omega$  resistor into each pin.

**Note 6:** See AN450 "Surface Mounting Methods and Their Effect on Product Reliability" or the section titled "Surface Mount" found in any post 1986 National Semiconductor Linear Data Book for other methods of soldering surface mount devices.

## AC Electrical Characteristics (Continued)

**Note 7:** Two on-chip diodes are tied to each analog input through a series resistor as shown below. Input voltage magnitude up to 5V above  $V_{A+}$  or 5V below GND will not damage this device. However, errors in the A/D conversion can occur (if these diodes are forward biased by more than 50 mV) if the input voltage magnitude of selected or unselected analog input go above  $V_{A+}$  or below GND by more than 50 mV. As an example, if  $V_{A+}$  is 4.5  $V_{DC}$ , full-scale input voltage must be  $\leq 4.5 V_{DC}$  to ensure accurate conversions.

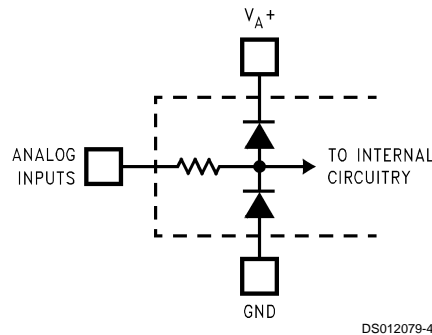

DS012079-4

**Note 8:** To guarantee accuracy, it is required that the  $V_{A+}$  and  $V_{D+}$  be connected together to the same power supply with separate bypass capacitors at each  $V^+$  pin.

**Note 9:** With the test condition for  $V_{REF}$  ( $V_{REF+} - V_{REF-}$ ) given as +4.096V, the 12-bit LSB is 1.0 mV. For  $V_{REF} = 2.5V$ , the 12-bit LSB is 610  $\mu V$ .

**Note 10:** Typicals are at  $T_J = T_A = 25^\circ C$  and represent most likely parametric norm.

**Note 11:** Tested limits are guaranteed to National's AOQL (Average Outgoing Quality Level).

**Note 12:** Positive integral linearity error is defined as the deviation of the analog value, expressed in LSBs, from the straight line that passes through positive full-scale and zero. For negative integral linearity error, the straight line passes through negative full-scale and zero (see Figure 2 and Figure 3).

**Note 13:** Zero error is a measure of the deviation from the mid-scale voltage (a code of zero), expressed in LSB. It is the average value of the code transitions between -1 to 0 and 0 to +1 (see Figure 4).

**Note 14:** Total unadjusted error includes offset, full-scale, linearity and multiplexer errors.

**Note 15:** The DC common-mode error is measured in the differential multiplexer mode with the assigned positive and negative input channels shorted together.

**Note 16:** Channel leakage current is measured after the channel selection.

**Note 17:** Timing specifications are tested at the TTL logic levels,  $V_{OL} = 0.4V$  for a falling edge and  $V_{OH} = 2.4V$  for a rising edge. TRI-STATE output voltage is forced to 1.4V.

**Note 18:** The ADC12130 family's self-calibration technique ensures linearity and offset errors as specified, but noise inherent in the self-calibration process will result in a maximum repeatability uncertainty of 0.2 LSB.

**Note 19:** If SCLK and CCLK are driven from the same clock source, then  $t_A$  is 6, 10, 18 or 34 clock periods minimum and maximum.

**Note 20:** The "12-Bit Conversion of Offset" and "12-Bit Conversion of Full-Scale" modes are intended to test the functionality of the device. Therefore, the output data from these modes are not an indication of the accuracy of a conversion result.

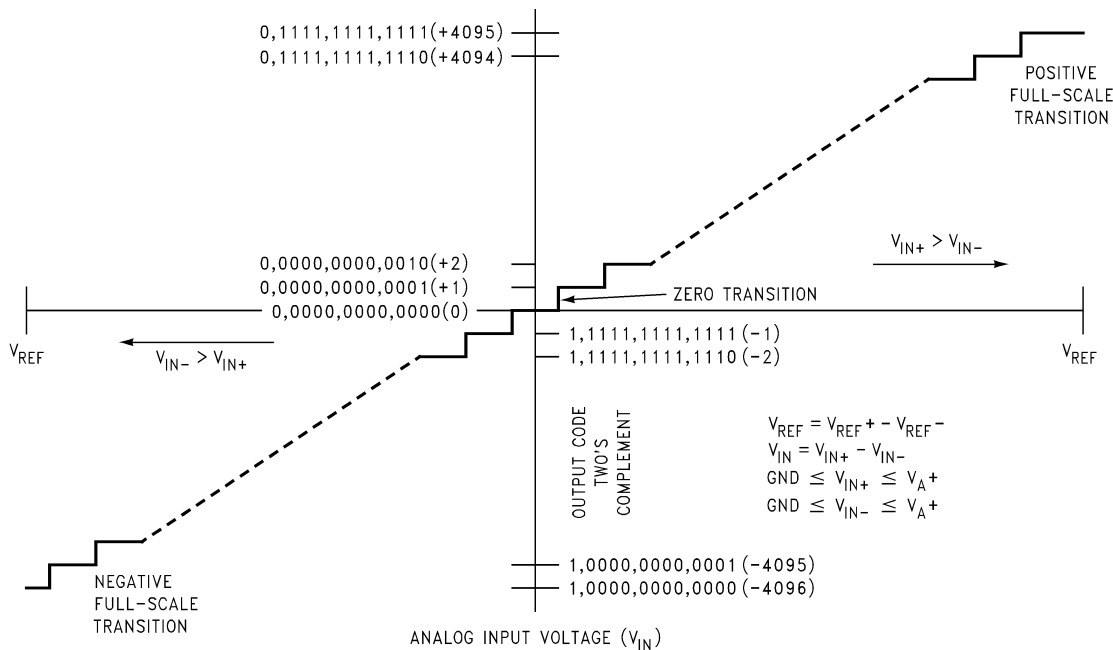

DS012079-5

FIGURE 1. Transfer Characteristic

AC Electrical Characteristics (Continued)

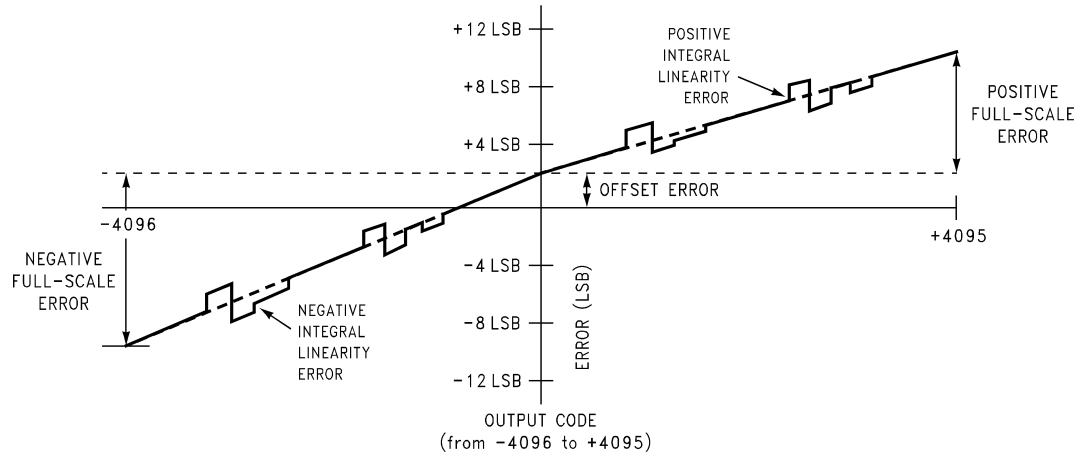

DS012079-6

FIGURE 2. Simplified Error Curve vs Output Code without Auto-Calibration or Auto-Zero Cycles

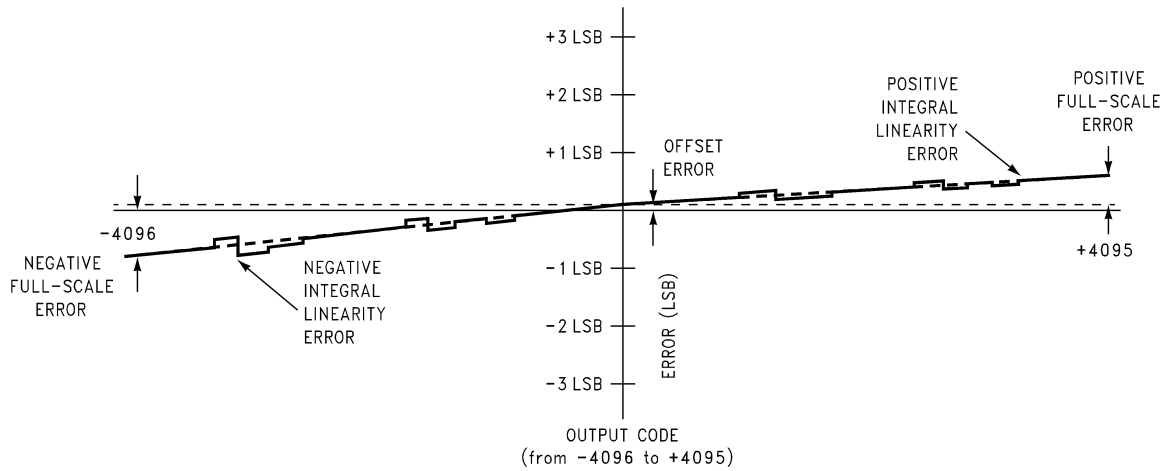

DS012079-7

FIGURE 3. Simplified Error Curve vs Output Code after Auto-Calibration Cycle

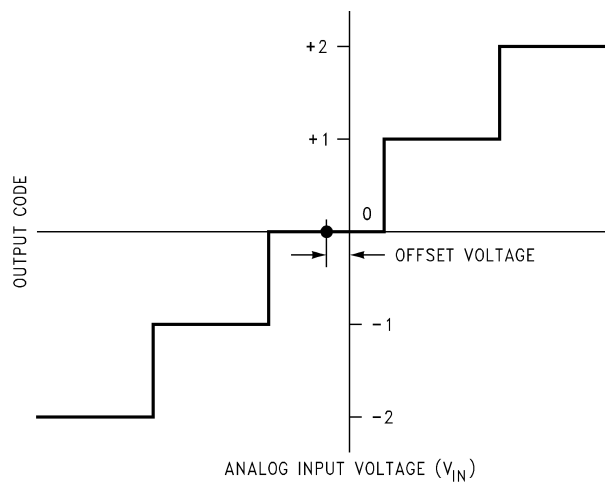

DS012079-8

FIGURE 4. Offset or Zero Error Voltage

**Typical Performance Characteristics** The following curves apply for 12-bit + sign mode after auto-calibration unless otherwise specified.

**Linearity Error Change vs Clock Frequency**

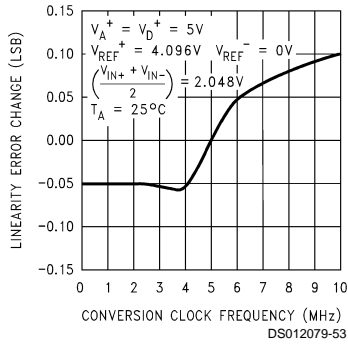

**Linearity Error Change vs Temperature**

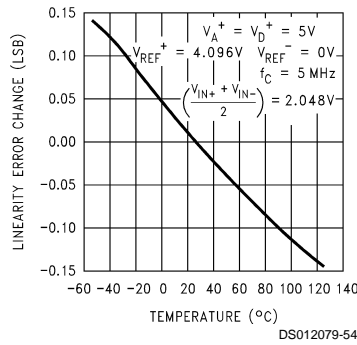

**Linearity Error Change vs Reference Voltage**

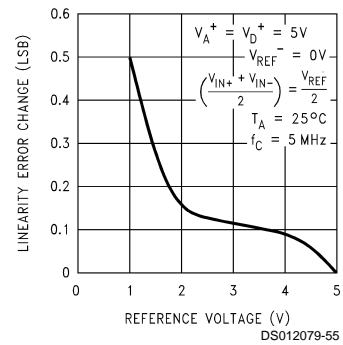

**Linearity Error Change vs Supply Voltage**

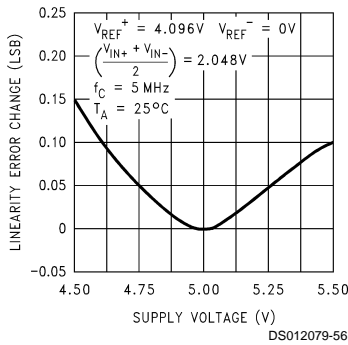

**Full-Scale Error Change vs Clock Frequency**

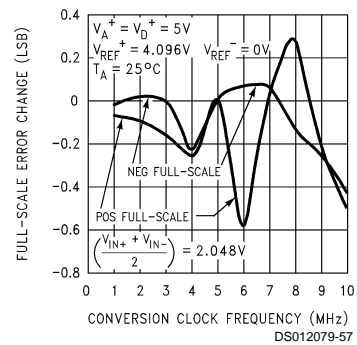

**Full-Scale Error Change vs Temperature**

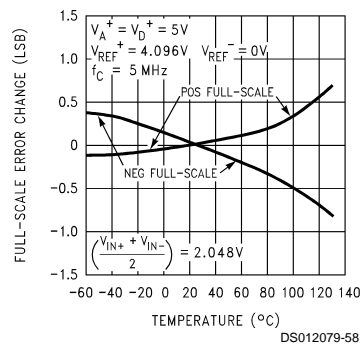

**Full-Scale Error Change vs Reference Voltage**

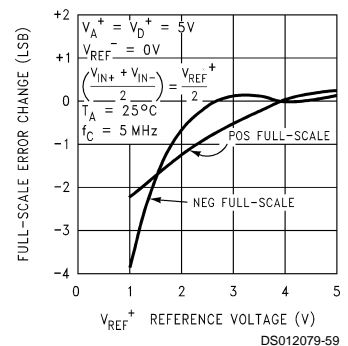

**Full-Scale Error Change vs Supply Voltage**

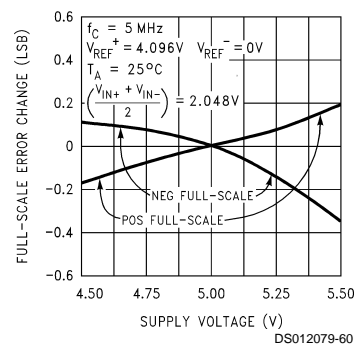

**Zero Error Change vs Clock Frequency**

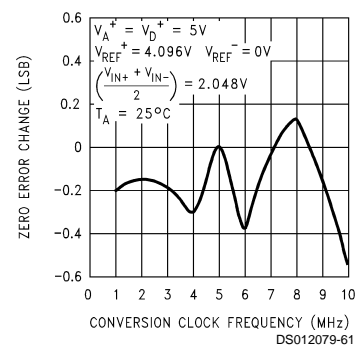

**Typical Performance Characteristics** The following curves apply for 12-bit + sign mode after auto-calibration unless otherwise specified. (Continued)

**Zero Error Change vs Temperature**

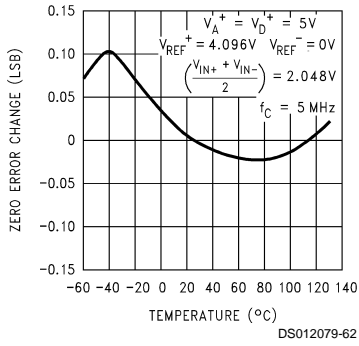

**Zero Error Change vs Reference Voltage**

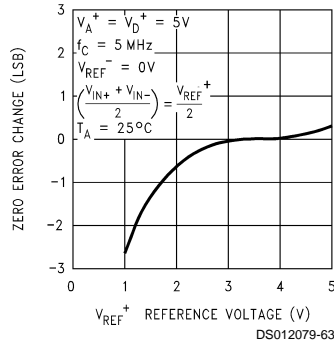

**Zero Error Change vs Supply Voltage**

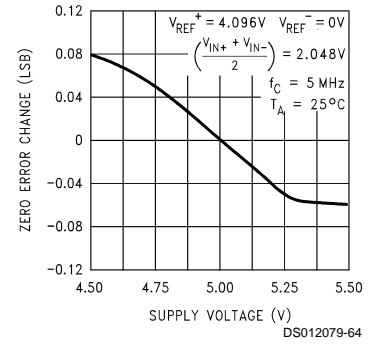

**Analog Supply Current vs Temperature**

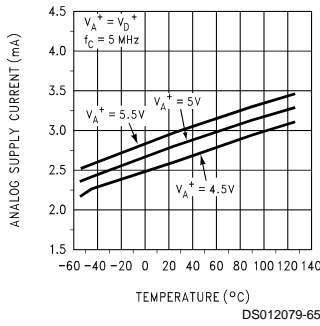

**Digital Supply Current vs Clock Frequency**

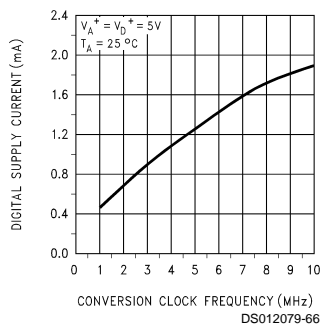

**Digital Supply Current vs Temperature**

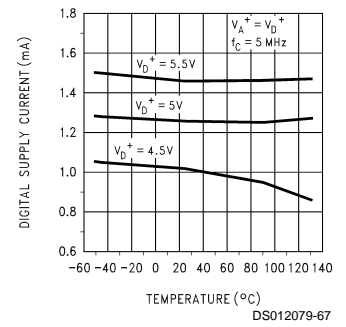

**Linearity Error Change vs Temperature**

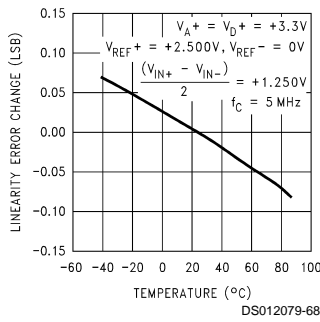

**Full-Scale Error Change vs Temperature**

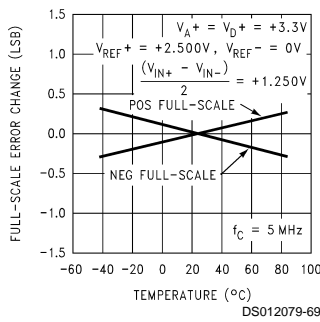

**Full-Scale Error Change vs Supply Voltage**

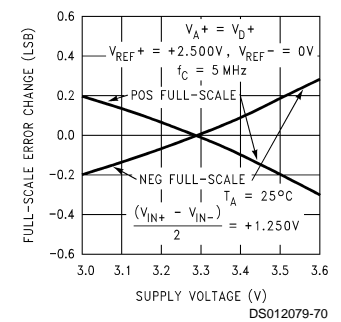

**Zero Error Change vs Temperature**

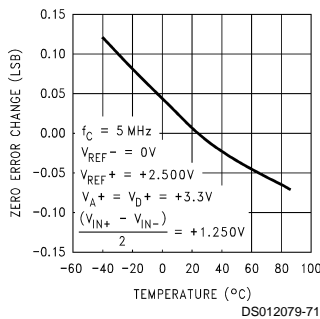

**Zero Error Change vs Supply Voltage**

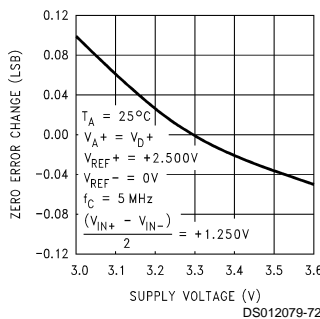

**Analog Supply Current vs Temperature**

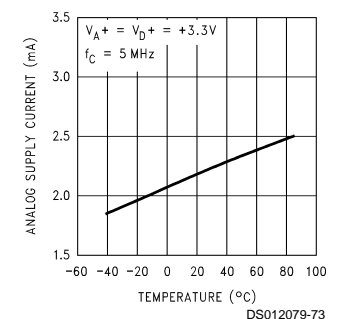

**Typical Performance Characteristics** The following curves apply for 12-bit + sign mode after auto-calibration unless otherwise specified. (Continued)

**Digital Supply Current vs Temperature**

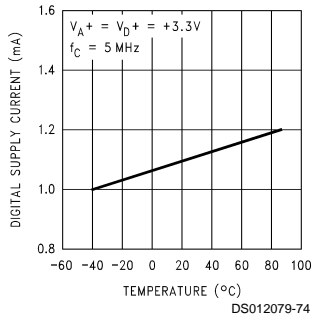

**Typical Dynamic Performance Characteristics** The following curves apply for 12-bit + sign mode after auto-calibration unless otherwise specified.

**Bipolar Spectral Response with 1 kHz Sine Wave Input**

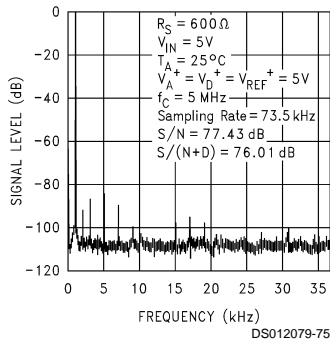

**Bipolar Spectral Response with 10 kHz Sine Wave Input**

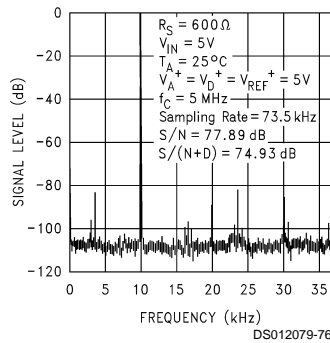

**Bipolar Spectral Response with 20 kHz Sine Wave Input**

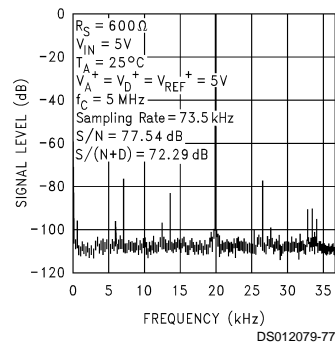

**Bipolar Spectral Response with 30 kHz Sine Wave Input**

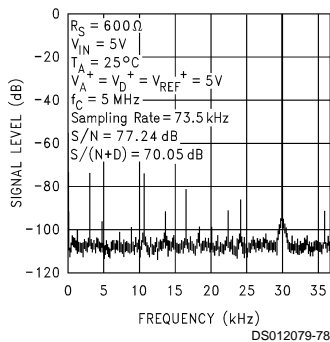

**Bipolar Spectral Response with 40 kHz Sine Wave Input**

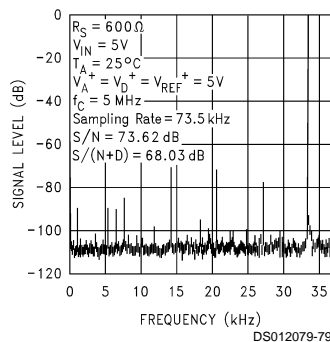

**Bipolar Spectral Response with 50 kHz Sine Wave Input**

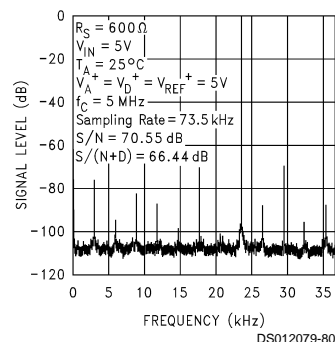

# Typical Dynamic Performance Characteristics

The following curves apply for 12-bit + sign mode after auto-calibration unless otherwise specified. (Continued)

**Bipolar Spurious Free Dynamic Range**

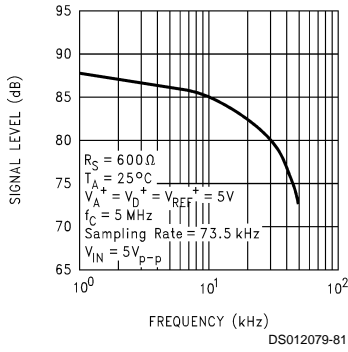

**Unipolar Signal-to-Noise Ratio vs Input Frequency**

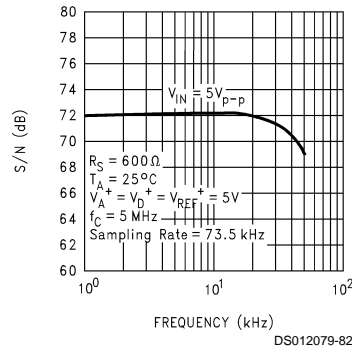

**Unipolar Signal-to-Noise + Distortion Ratio vs Input Frequency**

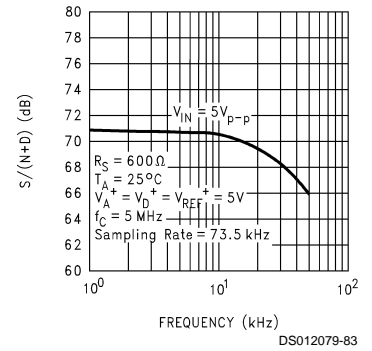

**Unipolar Signal-to-Noise + Distortion Ratio vs Input Signal Level**

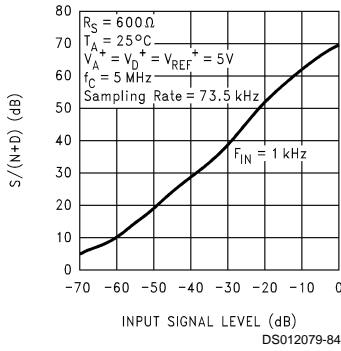

**Unipolar Spectral Response with 1 kHz Sine Wave Input**

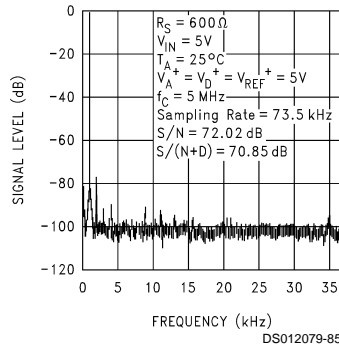

**Unipolar Spectral Response with 10 kHz Sine Wave Input**

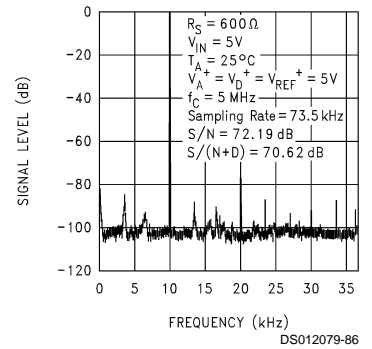

**Unipolar Spectral Response with 20 kHz Sine Wave Input**

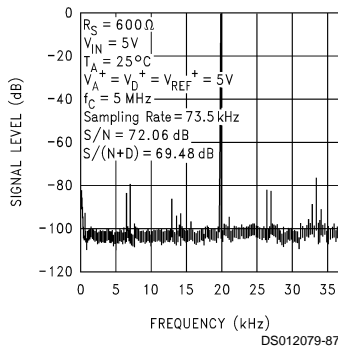

**Unipolar Spectral Response with 30 kHz Sine Wave Input**

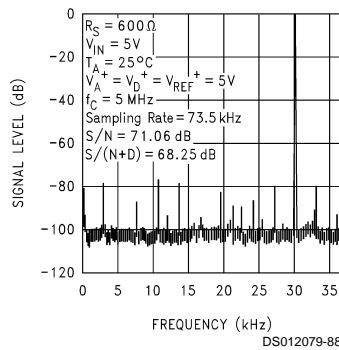

**Unipolar Spectral Response with 40 kHz Sine Wave Input**

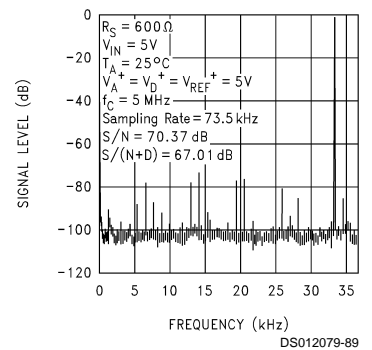

## Typical Dynamic Performance Characteristics

The following curves apply for 12-bit + sign mode after auto-calibration unless otherwise specified. (Continued)

### Unipolar Spectral Response with 50 kHz Sine Wave Input

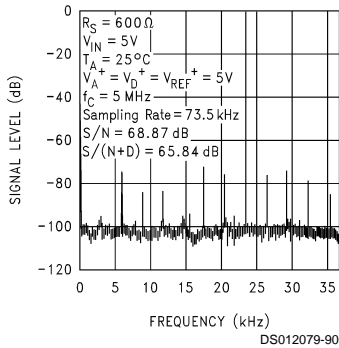

## Test Circuits

### DO "TRI-STATE" ( $t_{1H}$ , $t_{0H}$ )

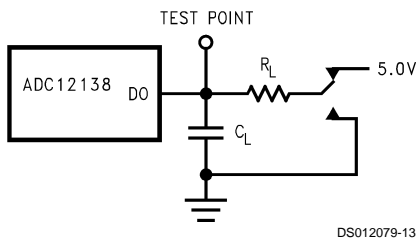

### DO except "TRI-STATE"

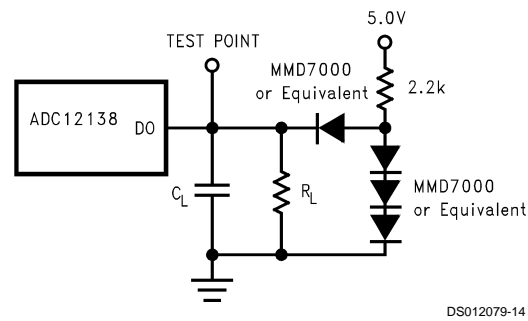

### Leakage Current

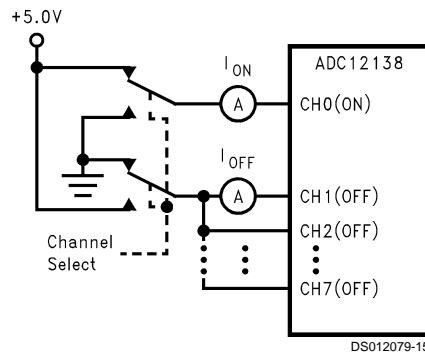

## Timing Diagrams

### DO Falling and Rising Edge

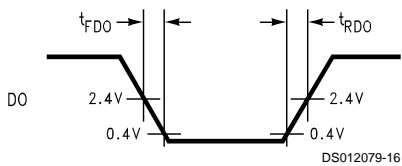

### DO "TRI-STATE" Falling and Rising Edge

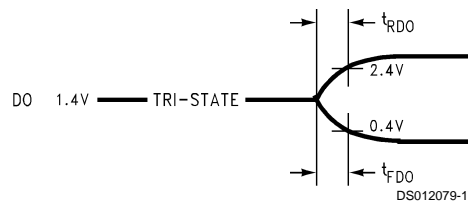

Timing Diagrams (Continued)

DI Data Input Timing

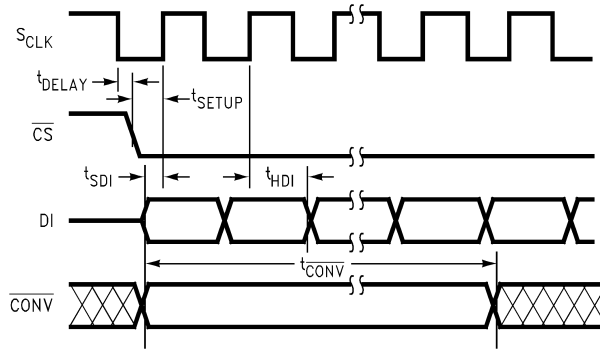

DS012079-18

DO Data Output Timing Using CS

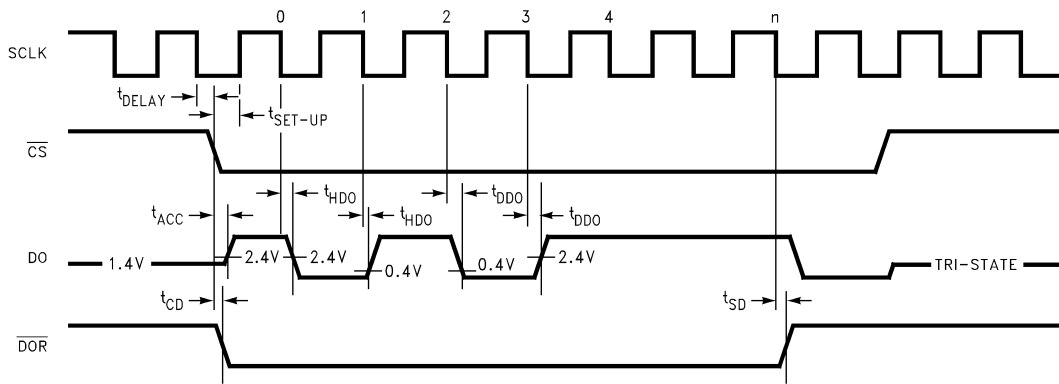

DS012079-19

DO Data Output Timing with CS Continuously Low

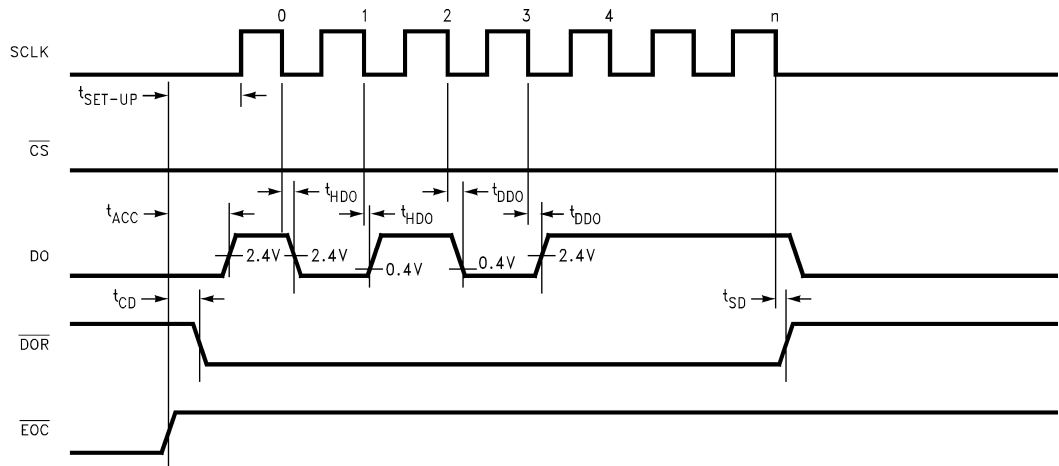

DS012079-20

Timing Diagrams (Continued)

ADC12138 Auto Cal or Auto Zero

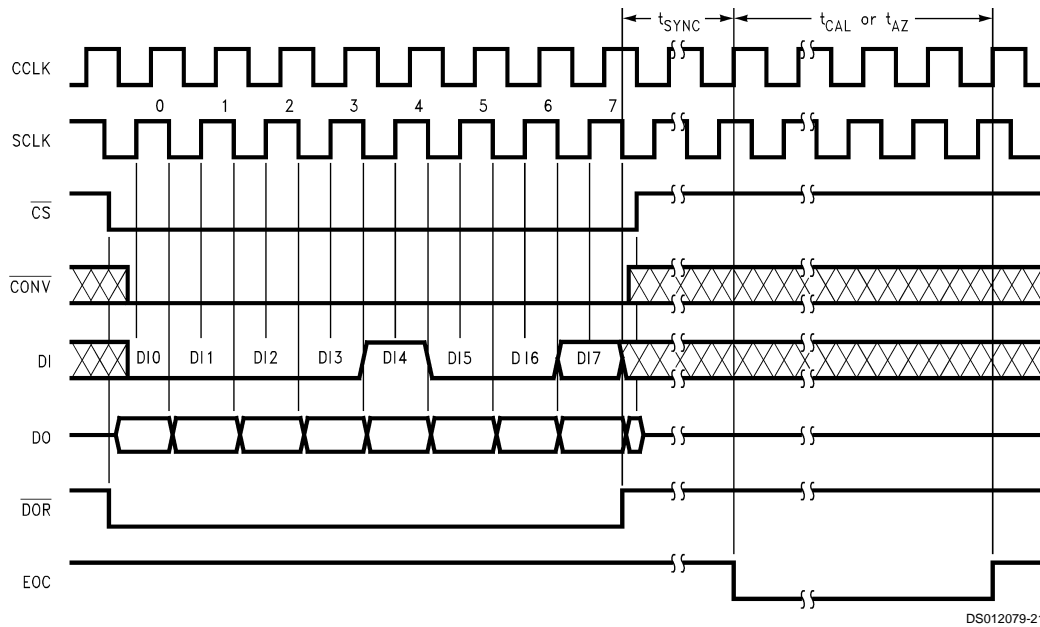

DS012079-21

Note: DO output data is not valid during this cycle.

ADC12138 Read Data without Starting a Conversion Using CS

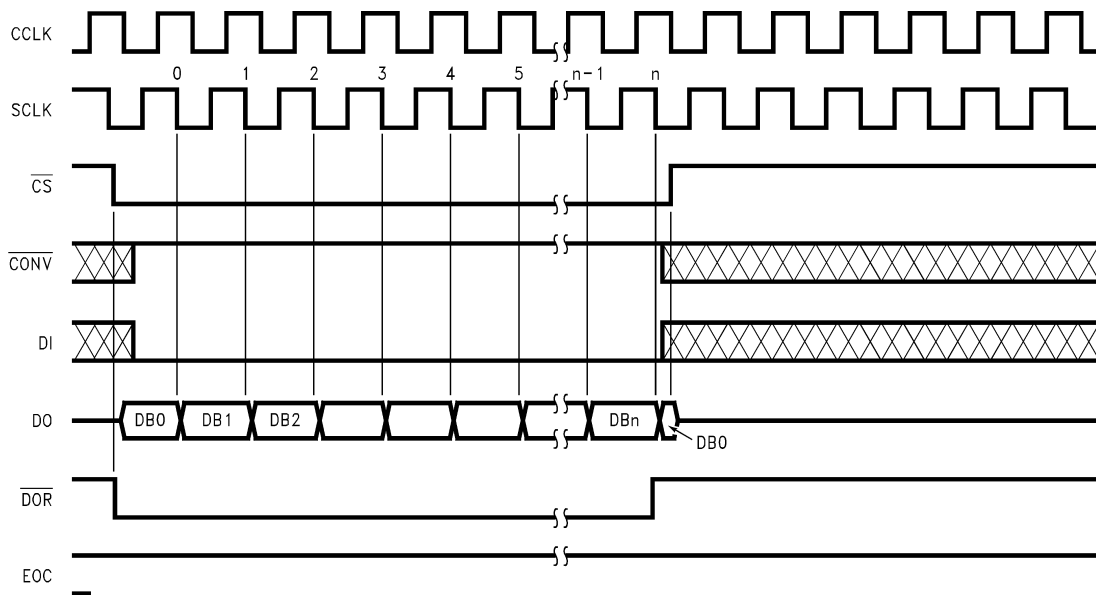

DS012079-22

Timing Diagrams (Continued)

ADC12138 Read Data without Starting a Conversion with  $\overline{CS}$  Continuously Low

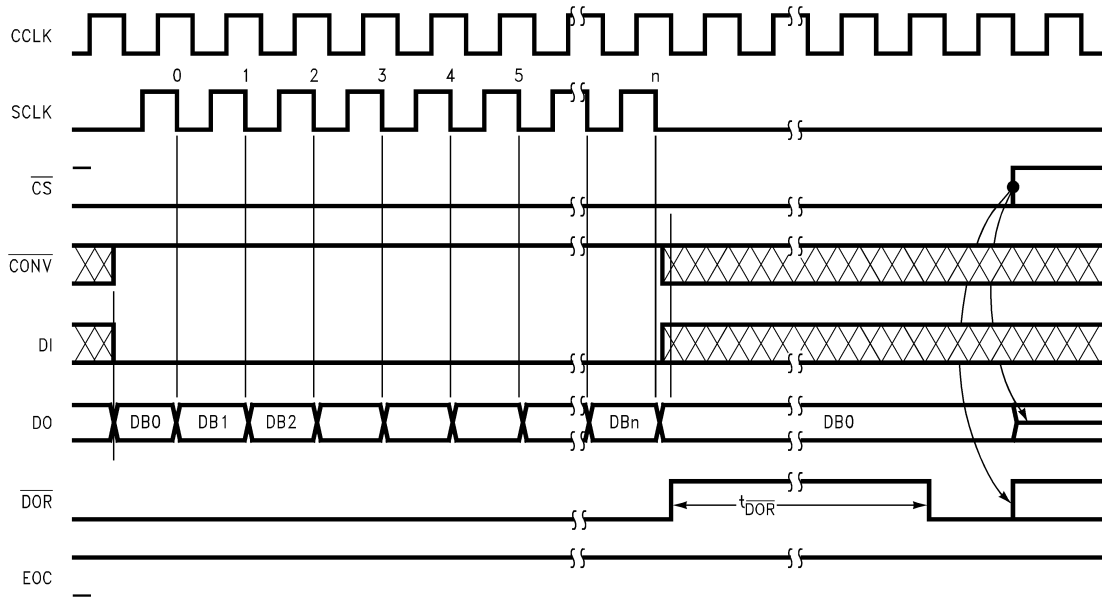

DS012079-23

ADC12138 Conversion Using  $\overline{CS}$  with 16-Bit Digital Output Format

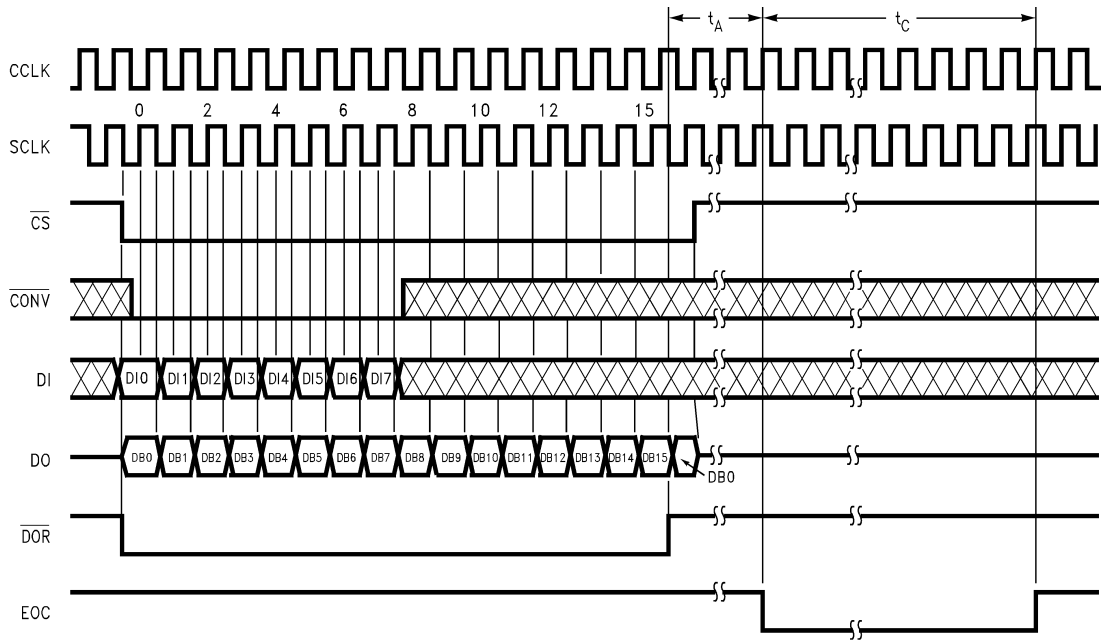

DS012079-24

# Timing Diagrams (Continued)

**ADC12138 Conversion with  $\overline{CS}$  Continuously Low and 16-Bit Digital Output Format**

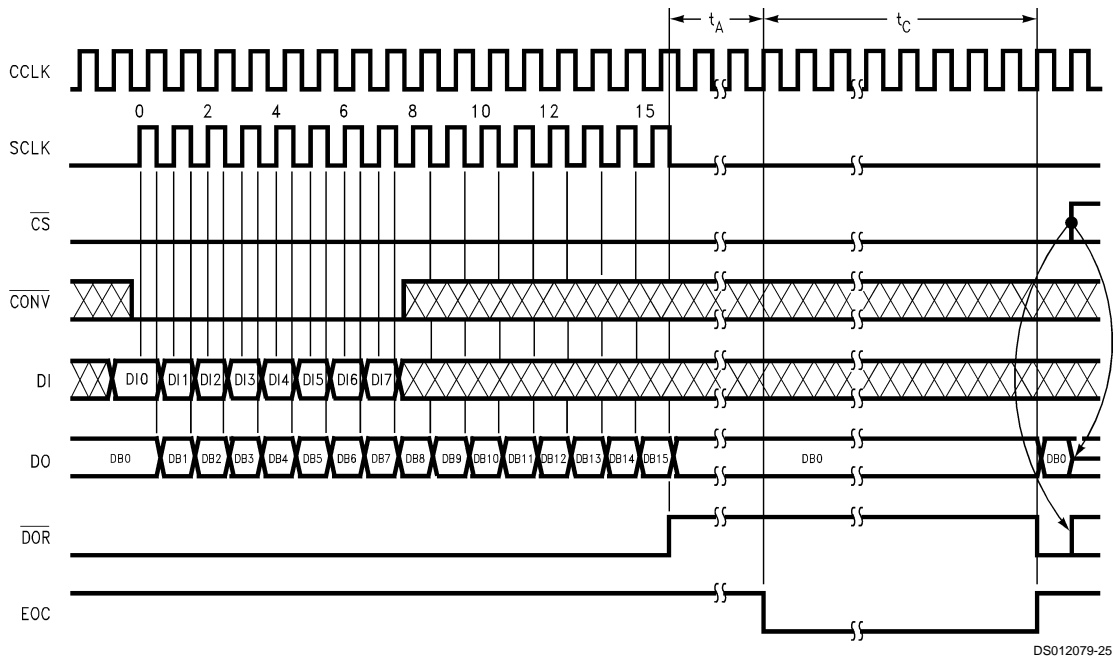

**ADC12138 Software Power Up/Down Using  $\overline{CS}$  with 16-Bit Digital Output Format**

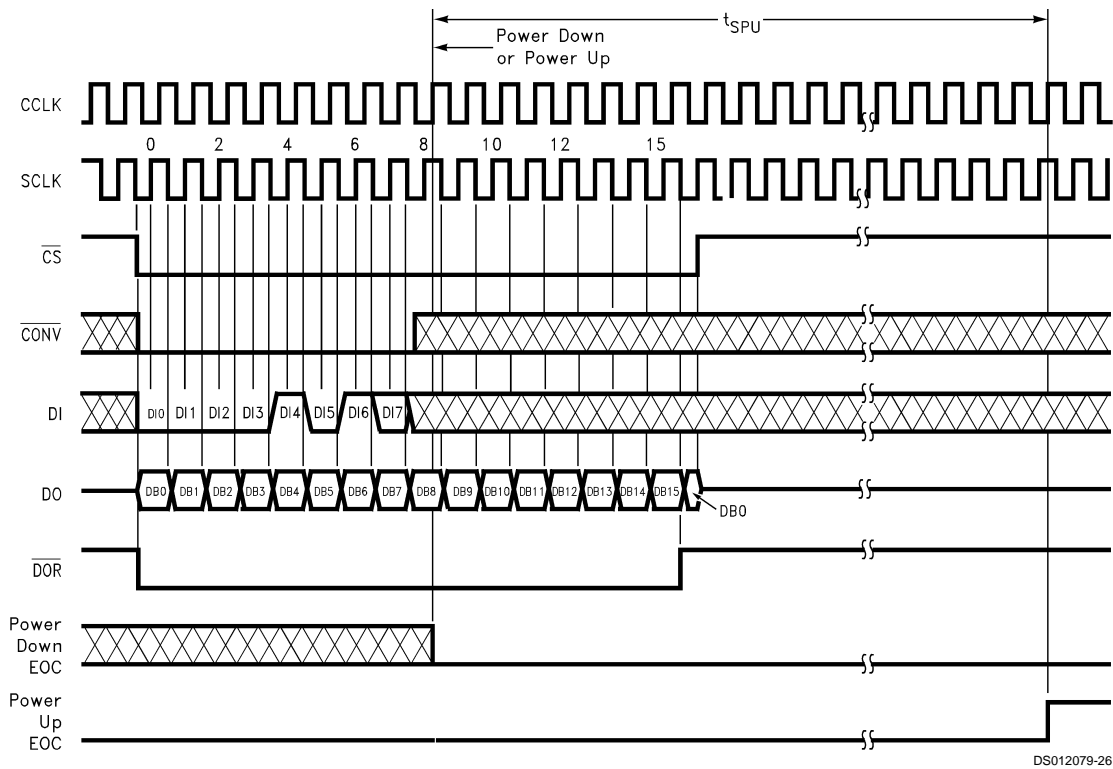

## Timing Diagrams (Continued)

ADC12138 Software Power Up/Down with  $\overline{CS}$  Continuously Low and 16-Bit Digital Output Format

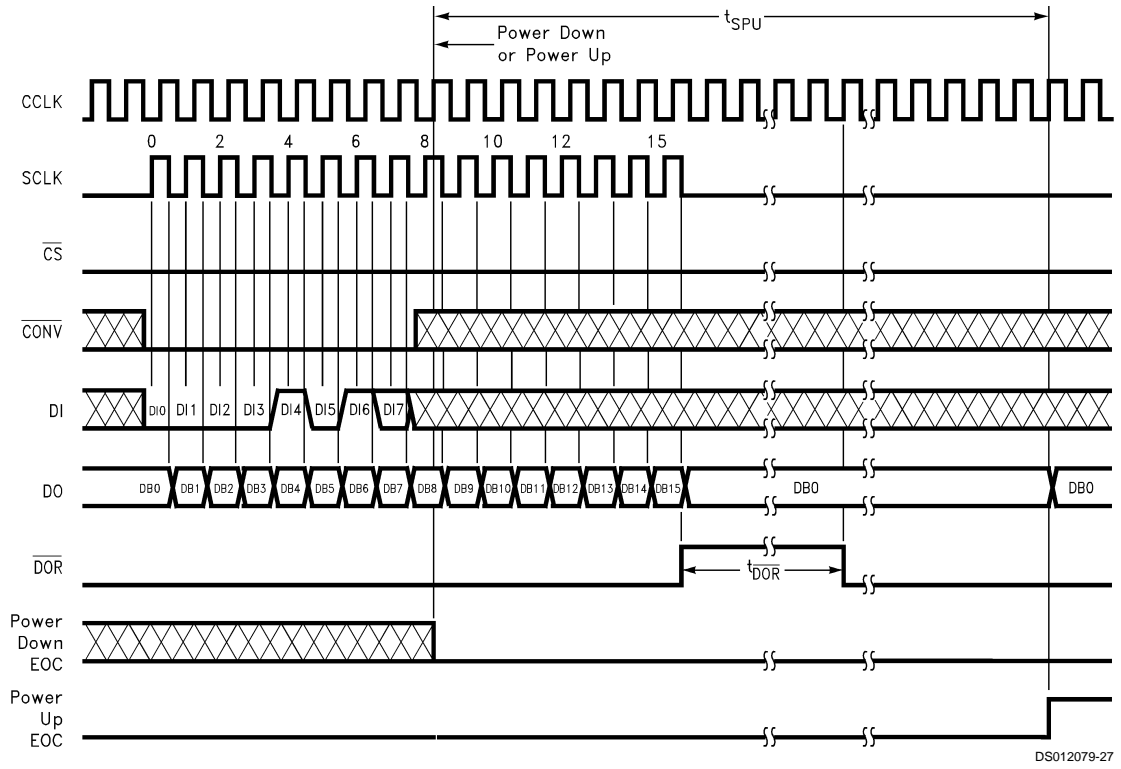

DS012079-27

ADC12138 Hardware Power Up/Down

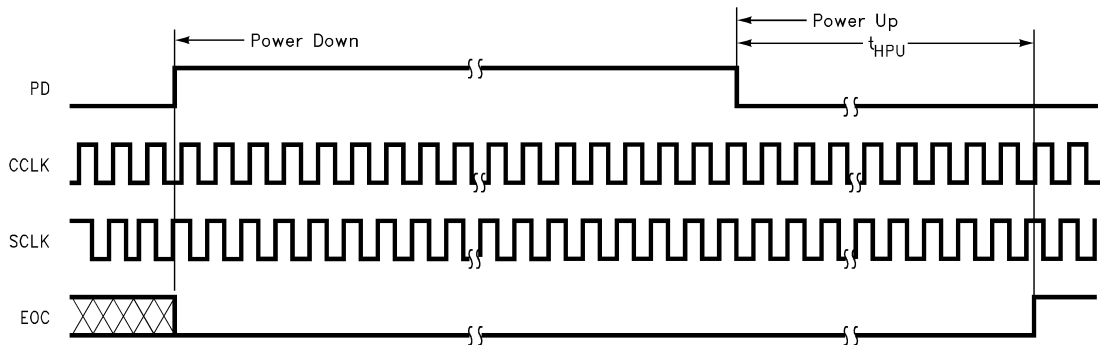

DS012079-28

**Note:** Hardware power up/down may occur at any time. If  $PD$  is high while a conversion is in progress that conversion will be corrupted and erroneous data will be stored in the output shift register.

Timing Diagrams (Continued)

ADC12138 Configuration Modification—Example of a Status Read

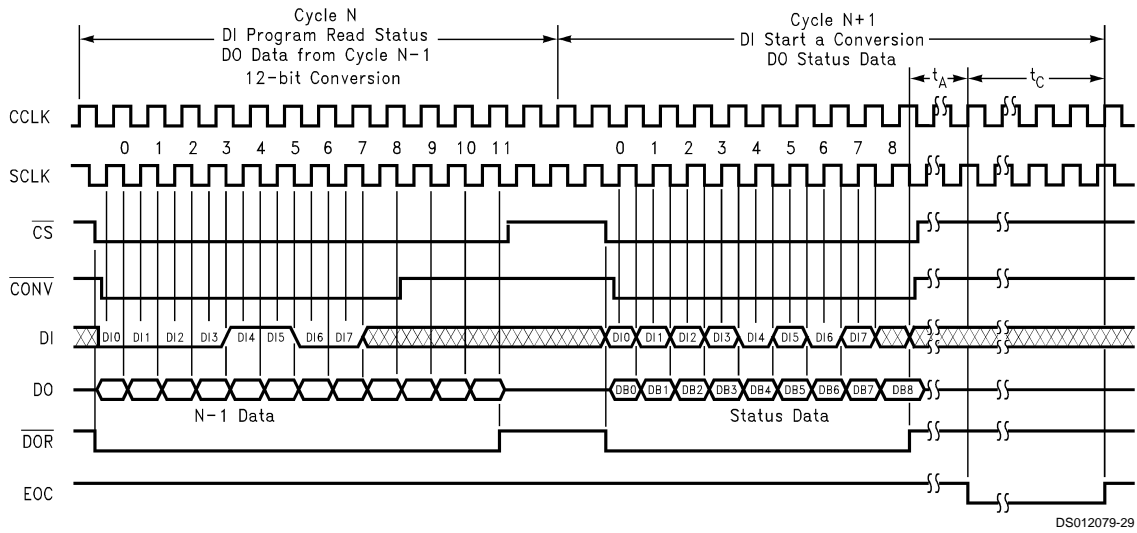

DS012079-29

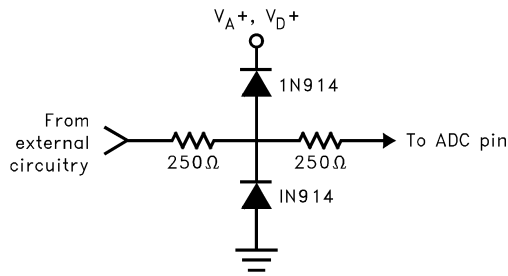

DS012079-30

FIGURE 5. Protecting the MUXOUT1, MUXOUT2, A/DIN1 and A/DIN2 Analog Pins

Timing Diagrams (Continued)

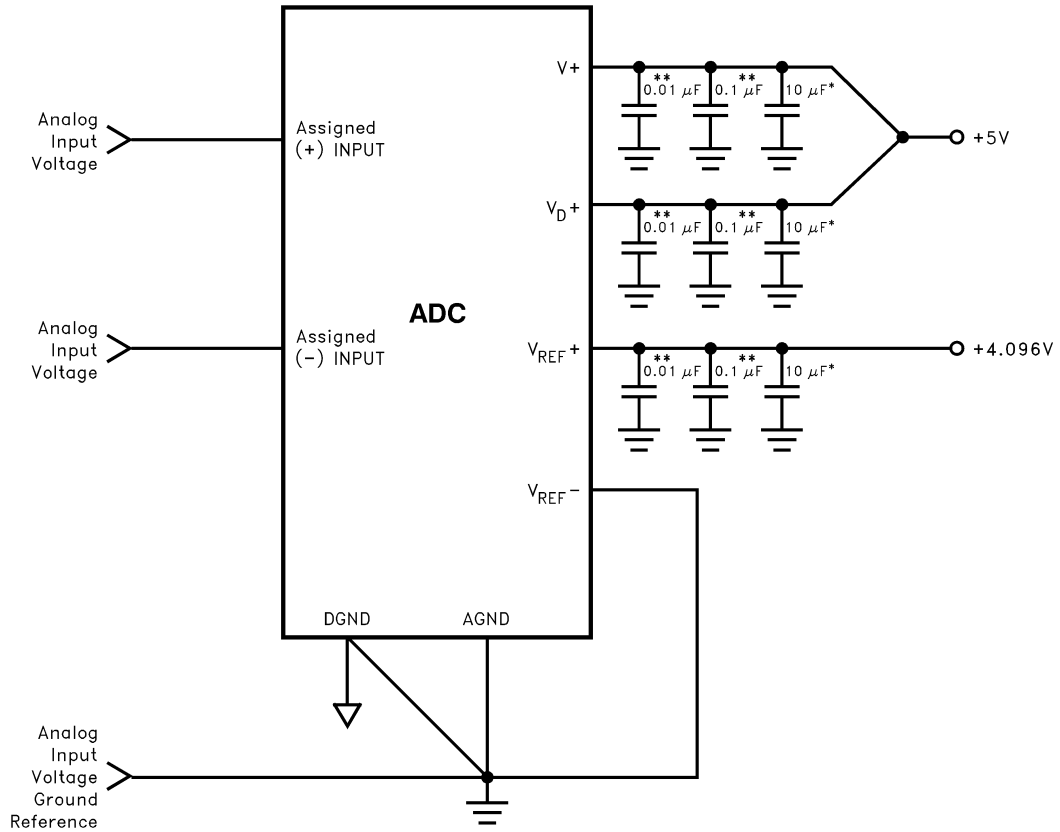

DS012079-31

\*Tantalum  
\*\*Monolithic Ceramic or better

FIGURE 6. Recommended Power Supply Bypassing and Grounding

# Tables

**TABLE 1. Data Out Formats**

| DO Formats      |              |            | DB0  | DB1 | DB2 | DB3 | DB4  | DB5 | DB6 | DB7 | DB8 | DB9 | DB10 | DB11 | DB12 | DB13 | DB14 | DB15 | DB16 |  |
|-----------------|--------------|------------|------|-----|-----|-----|------|-----|-----|-----|-----|-----|------|------|------|------|------|------|------|--|
| with<br>Sign    | MSB<br>First | 17<br>Bits | X    | X   | X   | X   | Sign | MSB | 10  | 9   | 8   | 7   | 6    | 5    | 4    | 3    | 2    | 1    | LSB  |  |
|                 |              | 13<br>Bits | Sign | MSB | 10  | 9   | 8    | 7   | 6   | 5   | 4   | 3   | 2    | 1    | LSB  |      |      |      |      |  |
|                 | LSB<br>First | 17<br>Bits | LSB  | 1   | 2   | 3   | 4    | 5   | 6   | 7   | 8   | 9   | 10   | MSB  | Sign | X    | X    | X    | X    |  |
|                 |              | 13<br>Bits | LSB  | 1   | 2   | 3   | 4    | 5   | 6   | 7   | 8   | 9   | 10   | MSB  | Sign |      |      |      |      |  |
| without<br>Sign | MSB<br>First | 16<br>Bits | 0    | 0   | 0   | 0   | MSB  | 10  | 9   | 8   | 7   | 6   | 5    | 4    | 3    | 2    | 1    | LSB  |      |  |
|                 |              | 12<br>Bits | MSB  | 10  | 9   | 8   | 7    | 6   | 5   | 4   | 3   | 2   | 1    | LSB  |      |      |      |      |      |  |
|                 | LSB<br>First | 16<br>Bits | LSB  | 1   | 2   | 3   | 4    | 5   | 6   | 7   | 8   | 9   | 10   | MSB  | 0    | 0    | 0    | 0    |      |  |
|                 |              | 12<br>Bits | LSB  | 1   | 2   | 3   | 4    | 5   | 6   | 7   | 8   | 9   | 10   | MSB  |      |      |      |      |      |  |

X = High or Low state.

**TABLE 2. ADC12138 Multiplexer Addressing**

| MUX Address |     |     |     | Analog Channel Addressed and Assignment with A/DIN1 tied to MUXOUT1 and A/DIN2 tied to MUXOUT2 |     |     |     |     |     |     |     |     | A/D Input Polarity Assignment |        | Multiplexer Output Channel Assignment |         | Mode         |
|-------------|-----|-----|-----|--|-----|-----|-----|-----|-----|-----|-----|-----|-------------------------------|--------|---------------------------------------|---------|--------------|
| DI0         | DI1 | DI2 | DI3 | CH0  | CH1 | CH2 | CH3 | CH4 | CH5 | CH6 | CH7 | COM | A/DIN1                        | A/DIN2 | MUXOUT1                               | MUXOUT2 |              |
| L           | L   | L   | L   | +  | -   |     |     |     |     |     |     |     | +                             | -      | CH0                                   | CH1     | Differential |
| L           | L   | L   | H   |  |     | +   | -   |     |     |     |     |     | +                             | -      | CH2                                   | CH3     |              |
| L           | L   | H   | L   |  |     |     |     | +   | -   |     |     |     | +                             | -      | CH4                                   | CH5     |              |
| L           | L   | H   | H   |  |     |     |     |     |     | +   | -   |     | +                             | -      | CH6                                   | CH7     |              |
| L           | H   | L   | L   | -  | +   |     |     |     |     |     |     |     | -                             | +      | CH0                                   | CH1     |              |
| L           | H   | L   | H   |  |     | -   | +   |     |     |     |     |     | -                             | +      | CH2                                   | CH3     |              |
| L           | H   | H   | L   |  |     |     |     | -   | +   |     |     |     | -                             | +      | CH4                                   | CH5     |              |
| L           | H   | H   | H   |  |     |     |     |     |     | -   | +   |     | -                             | +      | CH6                                   | CH7     |              |
| H           | L   | L   | L   | +  |     |     |     |     |     |     |     | -   | +                             | -      | CH0                                   | COM     | Single-Ended |
| H           | L   | L   | H   |  |     | +   |     |     |     |     |     | -   | +                             | -      | CH2                                   | COM     |              |
| H           | L   | H   | L   |  |     |     |     | +   |     |     |     | -   | +                             | -      | CH4                                   | COM     |              |
| H           | L   | H   | H   |  |     |     |     |     |     | +   |     | -   | +                             | -      | CH6                                   | COM     |              |
| H           | H   | L   | L   |  | +   |     |     |     |     |     |     | -   | +                             | -      | CH1                                   | COM     |              |
| H           | H   | L   | H   |  |     |     | +   |     |     |     |     | -   | +                             | -      | CH3                                   | COM     |              |
| H           | H   | H   | L   |  |     |     |     |     | +   |     |     | -   | +                             | -      | CH5                                   | COM     |              |
| H           | H   | H   | H   |  |     |     |     |     |     | +   |     | -   | +                             | -      | CH7                                   | COM     |              |

## Tables (Continued)

### TABLE 3. ADC12130 and ADC12132 Multiplexer Addressing

| MUX Address |     | Analog Channel Addressed and Assignment<br>with A/DIN1 tied to MUXOUT1<br>and A/DIN2 tied to MUXOUT2 |     |     | A/D Input Polarity Assignment |        | Multiplexer Output Channel Assignment |         | Mode         |
|-------------|-----|--|-----|-----|-------------------------------|--------|---------------------------------------|---------|--------------|
| DI0         | DI1 | CH0  | CH1 | COM | A/DIN1                        | A/DIN2 | MUXOUT1                               | MUXOUT2 |              |
| L           | L   | +  | -   |     | +                             | -      | CH0                                   | CH1     | Differential |
| L           | H   | -  | +   |     | -                             | +      | CH0                                   | CH1     |              |
| H           | L   | +  |     | -   | +                             | -      | CH0                                   | COM     | Single-Ended |
| H           | H   |  | +   | -   | +                             | -      | CH1                                   | COM     |              |

Note: ADC12130 do not have A/DIN1, A/DIN2, MUXOUT1 and MUXOUT2 pins.

### TABLE 4. Mode Programming

| ADC12138              | DI0                    | DI1 | DI2 | DI3 | DI4 | DI5 | DI6 | DI7 | Mode Selected (Current)                      | DO Format (next Conversion Cycle) |
|-----------------------|------------------------|-----|-----|-----|-----|-----|-----|-----|--|-----------------------------------|
| ADC12130 and ADC12132 | DI0                    | DI1 |     |     | DI2 | DI3 | DI4 | DI5 |  |                                   |
|                       | See Table 2 or Table 3 |     |     |     | L   | L   | L   | L   | 12 Bit Conversion                            | 12 or 13 Bit MSB First            |
|                       | See Table 2 or Table 3 |     |     |     | L   | L   | L   | H   | 12 Bit Conversion                            | 16 or 17 Bit MSB First            |
|                       | See Table 2 or Table 3 |     |     |     | L   | H   | L   | L   | 12 Bit Conversion                            | 12 or 13 Bit LSB First            |
|                       | See Table 2 or Table 3 |     |     |     | L   | H   | L   | H   | 12 Bit Conversion                            | 16 or 17 Bit LSB First            |
|                       | L                      | L   | L   | L   | H   | L   | L   | L   | Auto Cal                                     | No Change                         |
|                       | L                      | L   | L   | L   | H   | L   | L   | H   | Auto Zero                                    | No Change                         |
|                       | L                      | L   | L   | L   | H   | L   | H   | L   | Power Up                                     | No Change                         |
|                       | L                      | L   | L   | L   | H   | L   | H   | H   | Power Down                                   | No Change                         |
|                       | L                      | L   | L   | L   | H   | H   | L   | L   | Read Status Register                         | No Change                         |
|                       | L                      | L   | L   | L   | H   | H   | L   | H   | Data Out without Sign                        | No Change                         |
|                       | H                      | L   | L   | L   | H   | H   | L   | H   | Data Out with Sign                           | No Change                         |
|                       | L                      | L   | L   | L   | H   | H   | H   | L   | Acquisition Time—6 CCLK Cycles               | No Change                         |
|                       | L                      | H   | L   | L   | H   | H   | H   | L   | Acquisition Time—10 CCLK Cycles              | No Change                         |
|                       | H                      | L   | L   | L   | H   | H   | H   | L   | Acquisition Time—18 CCLK Cycles              | No Change                         |
|                       | H                      | H   | L   | L   | H   | H   | H   | L   | Acquisition Time—34 CCLK Cycles              | No Change                         |
|                       | L                      | L   | L   | L   | H   | H   | H   | H   | User Mode                                    | No Change                         |
|                       | H                      | X   | X   | X   | H   | H   | H   | H   | Test Mode<br>(CH1–CH7 become Active Outputs) | No Change                         |

Note: The A/D powers up with no Auto Cal, no Auto Zero, 10 CCLK acquisition time, 12-bit + sign conversion, power up, 12- or 13-bit MSB First, and user mode. X = Don't Care

### TABLE 5. Conversion/Read Data Only Mode Programming

| $\overline{\text{CS}}$ | $\overline{\text{CONV}}$ | PD | Mode   |
|------------------------|--------------------------|----|--|
| L                      | L                        | L  | See Table 4 for Mode                           |
| L                      | H                        | L  | Read Only (Previous DO Format). No Conversion. |
| H                      | X                        | L  | Idle   |
| X                      | X                        | H  | Power Down                                     |

X = Don't Care

**Tables** (Continued)

**TABLE 6. Status Register**

| Status Bit Location | DB0   | DB1   | DB2  | DB3                     | DB4                                    | DB5                                    | DB6  | DB7   | DB8  |
|---------------------|---|---|--|-------------------------|--|--|--|---|--|
| Status Bit          | PU  | PD  | Cal  |                         | 12 or 13                               | 16 or 17                               | Sign   | Justification   | Test Mode  |
| Function            | Device Status                                       |   |  | DO Output Format Status |  |  |  |   |  |
|                     | “High” indicates a Power Up Sequence is in progress | “High” indicates a Power Down Sequence is in progress | “High” indicates an Auto-Cal Sequence is in progress | Not used                | “High” indicates a 12 or 13 bit format | “High” indicates a 16 or 17 bit format | “High” indicates that the sign bit is included. When “Low” the sign bit is not included. | When “High” the conversion result will be output MSB first. When “Low” the result will be output LSB first. | When “High” the device is in test mode. When “Low” the device is in user mode. |

**Application Hints**

**1.0 DIGITAL INTERFACE**

**1.1 Interface Concepts**

The example in *Figure 7* shows a typical sequence of events after the power is applied to the ADC12130/2/8:

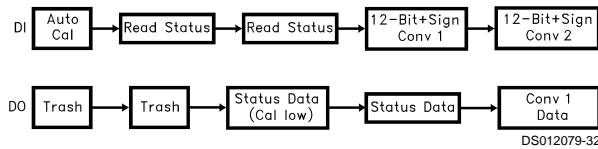

**FIGURE 7. Typical Power Supply Power Up Sequence**

The first instruction input to the A/D via DI initiates Auto Cal. The data output on DO at that time is meaningless and is completely random. To determine whether the Auto Cal has been completed, a read status instruction is issued to the A/D. Again the data output at that time has no significance since the Auto Cal procedure modifies the data in the output shift register. To retrieve the status information, an additional read status instruction is issued to the A/D. At this time the status data is available on DO. If the Cal signal in the status word, is low Auto Cal has been completed. Therefore, the next instruction issued can start a conversion. The data output at this time is again status information. To keep noise from corrupting the A/D conversion, status can not be read during a conversion. If  $\overline{CS}$  is strobed and is brought low during a conversion, that conversion is prematurely ended. EOC can be used to determine the end of a conversion or the A/D controller can keep track in software of when it would be appropriate to communicate to the A/D again. Once it has been determined that the A/D has completed a conversion, another instruction can be transmitted to the A/D. The data from this conversion can be accessed when the next instruction is issued to the A/D.

Note, when  $\overline{CS}$  is low continuously it is important to transmit the exact number of SCLK cycles, as shown in the timing diagrams. The Data Out Format sets the number of SCLK cycles required in the next I/O cycle. A 12-bit no sign format will require 12 SCLKs to be transmitted; a 12-bit plus sign

format will require 13 SCLKs to be transmitted, etc. Not doing so will desynchronize the serial communication to the A/D. (See Section 1.3.)

**1.2 Changing Configuration**

The configuration of the ADC12130/2/8 on power up defaults to 12-bit plus sign resolution, 12- or 13-bit MSB First, 10 CCLK acquisition time, user mode, no Auto Cal, no Auto Zero, and power up mode. Changing the acquisition time and turning the sign bit on and off requires an 8-bit instruction to be issued to the ADC. This instruction will not start a conversion. The instructions that select a multiplexer address and format the output data do start a conversion. *Figure 8* describes an example of changing the configuration of the ADC12130/2/8.

During I/O sequence 1, the instruction on DI configures the ADC12130/2/8 to do a conversion with 12-bit +sign resolution. Notice that when the 6 CCLK Acquisition and Data Out without Sign instructions are issued to the ADC, I/O sequences 2 and 3, a new conversion is not started. The data output during these instructions is from conversion N which was started during I/O sequence 1. The Configuration Modification timing diagram describes in detail the sequence of events necessary for a Data Out without Sign, Data Out with Sign, or 6/10/18/34 CCLK Acquisition time mode selection. *Table 4* describes the actual data necessary to be input to the ADC to accomplish this configuration modification. The next instruction, shown in *Figure 8*, issued to the A/D starts conversion N+1 with 16-bit format with 12 bits of resolution formatted MSB first. Again the data output during this I/O cycle is the data from conversion N.

The number of SCLKs applied to the A/D during any conversion I/O sequence should vary in accord with the data out word format chosen during the previous conversion I/O sequence. The various formats and resolutions available are shown in *Table 1*. In *Figure 8*, since 16-bit without sign MSB first format was chosen during I/O sequence 4, the number of SCLKs required during I/O sequence 5 is 16. In the following I/O sequence the format changes to 12-bit without sign MSB first; therefore the number of SCLKs required during I/O sequence 6 changes accordingly to 12.

## Application Hints (Continued)

### 1.3 $\overline{CS}$ Low Continuously Considerations

When  $\overline{CS}$  is continuously low, it is important to transmit the exact number of SCLK pulses that the ADC expects. Not doing so will desynchronize the serial communications to the ADC. When the supply power is first applied to the ADC, it will expect to see 13 SCLK pulses for each I/O transmission. The number of SCLK pulses that the ADC expects to see is the same as the digital output word length. The digital output word length is controlled by the Data Out (DO) format. The DO format maybe changed any time a conversion is started or when the sign bit is turned on or off. The table below details out the number of clock periods required for different DO formats:

| DO Format               |          | Number of SCLKs Expected |
|-------------------------|----------|--------------------------|
| 12-Bit MSB or LSB First | SIGN OFF | 12                       |
|                         | SIGN ON  | 13                       |
| 16-Bit MSB or LSB first | SIGN OFF | 16                       |
|                         | SIGN ON  | 17                       |

If erroneous SCLK pulses desynchronize the communications, the simplest way to recover is by cycling the power supply to the device. Not being able to easily resynchronize the device is a shortcoming of leaving  $\overline{CS}$  low continuously.

The number of clock pulses required for an I/O exchange may be different for the case when  $\overline{CS}$  is left low continuously vs the case when  $\overline{CS}$  is cycled. Take the I/O sequence detailed in *Figure 7* (Typical Power Supply Sequence) as an example. The table below lists the number of SCLK pulses required for each instruction:

| Instruction          | $\overline{CS}$ Low Continuously | $\overline{CS}$ Strobed |
|----------------------|----------------------------------|-------------------------|
| Auto Cal             | 13 SCLKs                         | 8 SCLKs                 |
| Read Status          | 13 SCLKs                         | 8 SCLKs                 |
| Read Status          | 13 SCLKs                         | 8 SCLKs                 |
| 12-Bit + Sign Conv 1 | 13 SCLKs                         | 8 SCLKs                 |
| 12-Bit + Sign Conv 2 | 13 SCLKs                         | 13 SCLKs                |

### 1.4 Analog Input Channel Selection

The data input on DI also selects the channel configuration for a particular A/D conversion (see *Table 2*, *Table 3* and *Table 4*). In *Figure 8* the only times when the channel configuration could be modified would be during I/O sequences 1, 4, 5 and 6. Input channels are reselected before the start of each new conversion. Shown below is the data bit stream required on DI, during I/O sequence number 4 in *Figure 8*, to set CH1 as the positive input and CH0 as the negative input for the different versions of ADCs:

| Part Number           | DI Data |     |     |     |     |     |     |     |
|-----------------------|---------|-----|-----|-----|-----|-----|-----|-----|
|                       | DI0     | DI1 | DI2 | DI3 | DI4 | DI5 | DI6 | DI7 |
| ADC12130 and ADC12132 | L       | H   | L   | L   | H   | L   | X   | X   |
| ADC12138              | L       | H   | L   | L   | L   | L   | H   | L   |

Where X can be a logic high (H) or low (L).

### 1.5 Power Up/Down

The ADC may be powered down at any time by taking the PD pin HIGH or by the instruction input on DI (see *Table 4* and *Table 5*, and the Power Up/Down timing diagrams). When the ADC is powered down in this way, the circuitry necessary for an A/D conversion is deactivated. The circuitry necessary for digital I/O is kept active. Hardware power up/down is controlled by the state of the PD pin. Software power-up/down is controlled by the instruction issued to the ADC. If a software power up instruction is issued to the ADC while a hardware power down is in effect (PD pin high) the device will remain in the power-down state. If a software power down instruction is issued to the ADC while a hardware power up is in effect (PD pin low), the device will power down. When the device is powered down by software, it may be powered up by either issuing a software power up instruction or by taking PD pin high and then low. If the power down command is issued during an A/D conversion, that conversion is disrupted. Therefore, the data output after power up cannot be relied upon.

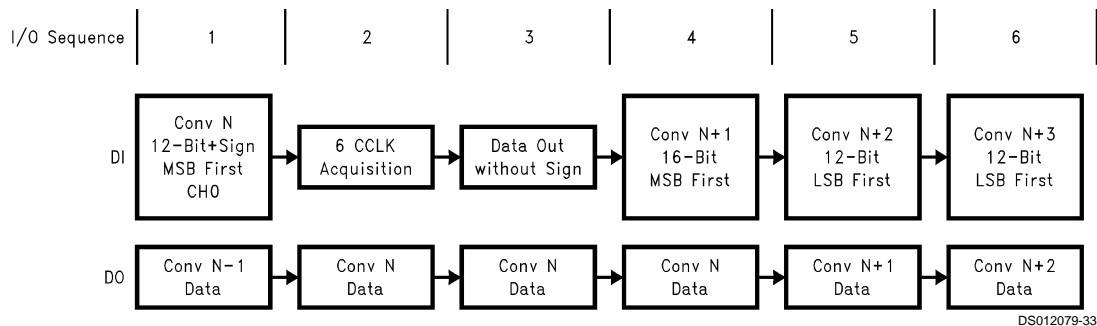

FIGURE 8. Changing the ADC's Conversion Configuration

### 1.6 User Mode and Test Mode

An instruction may be issued to the ADC to put it into test mode. Test mode is used by the manufacturer to verify complete functionality of the device. During test mode CH0–CH7 become active outputs. If the device is inadvertently put into

the test mode with  $\overline{CS}$  continuously low, the serial communications may be desynchronized. Synchronization may be regained by cycling the power supply voltage to the device. Cycling the power supply voltage will also set the device into user mode. If  $\overline{CS}$  is used in the serial interface, the ADC may

## Application Hints (Continued)

be queried to see what mode it is in. This is done by issuing a “read STATUS register” instruction to the ADC. When bit 9 of the status register is high, the ADC is in test mode; when bit 9 is low the ADC, is in user mode. As an alternative to cycling the power supply, an instruction sequence may be used to return the device to user mode. This instruction sequence must be issued to the ADC using  $\overline{CS}$ . The following table lists the instructions required to return the device to user mode:

| Instruction                 | DI Data |        |        |        |     |        |        |        |
|-----------------------------|---------|--------|--------|--------|-----|--------|--------|--------|
|                             | DI0     | DI1    | DI2    | DI3    | DI4 | DI5    | DI6    | DI7    |
| <b>TEST MODE</b>            | H       | X      | X      | X      | H   | H      | H      | H      |
| Reset                       | L       | L      | L      | L      | H   | H      | H      | L      |
| Test Mode Instructions      | L       | L      | L      | L      | H   | L      | H      | L      |
|                             | L       | L      | L      | L      | H   | L      | H      | H      |
| <b>USER MODE</b>            | L       | L      | L      | L      | H   | H      | H      | H      |
| Power Up                    | L       | L      | L      | L      | H   | L      | H      | L      |
| Set DO with or without Sign | H or L  | L      | L      | L      | H   | H      | L      | H      |
| Set Acquisition Time        | H or L  | H or L | L      | L      | H   | H      | H      | L      |
| Start a Conversion          | H or L  | H or L | H or L | H or L | L   | H or L | H or L | H or L |

X = Don't Care

After returning to user mode with the user mode instruction the power up, data with or without sign, and acquisition time instructions need to be resent to ensure that the ADC is in the required state before a conversion is started.

### 1.7 Reading the Data Without Starting a Conversion

The data from a particular conversion may be accessed without starting a new conversion by ensuring that the  $\overline{CONV}$  line is taken high during the I/O sequence. See the Read Data timing diagrams. *Table 5* describes the operation of the  $\overline{CONV}$  pin.

### 2.0 DESCRIPTION OF THE ANALOG MULTIPLEXER

For the ADC12138, the analog input multiplexer can be configured with 4 differential channels or 8 single ended channels with the COM input as the zero reference or any combination thereof (see *Figure 9*). The difference between the voltages on the  $V_{REF+}$  and  $V_{REF-}$  pins determines the input voltage span ( $V_{REF}$ ). The analog input voltage range is 0 to  $V_{A+}$ . Negative digital output codes result when  $V_{IN-} > V_{IN+}$ . The actual voltage at  $V_{IN-}$  or  $V_{IN+}$  cannot go below AGND.

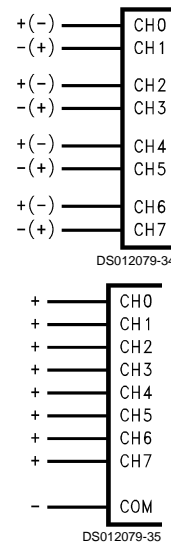
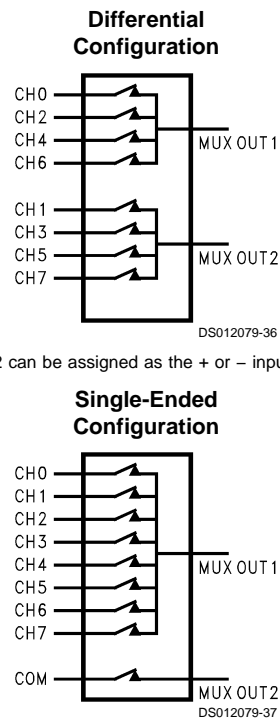

FIGURE 9.

CH0, CH2, CH4, and CH6 can be assigned to the MUXOUT1 pin in the differential configuration, while CH1, CH3, CH5, and CH7 can be assigned to the MUXOUT2 pin. In the differential configuration, the analog inputs are paired as follows: CH0 with CH1, CH2 with CH3, CH4 with CH5 and CH6 with CH7. The A/DIN1 and A/DIN2 pins can be assigned positive or negative polarity.

With the single-ended multiplexer configuration CH0 through CH7 can be assigned to the MUXOUT1 pin. The COM pin is always assigned to the MUXOUT2 pin. A/DIN1 is assigned as the positive input; A/DIN2 is assigned as the negative input. (See *Figure 10*).



A/DIN1 and A/DIN2 can be assigned as the + or - input

A/DIN1 is + input  
A/DIN2 is - input

FIGURE 10.

## Application Hints (Continued)

The Multiplexer assignment tables for the ADC12130/2/8 (Table 2 and Table 3) summarize the aforementioned functions for the different versions of A/Ds.

### 2.1 Biasing for Various Multiplexer Configurations

Figure 11 is an example of biasing the device for single-ended operation. The sign bit is always low. The digital output range is 0 0000 0000 0000 to 0 1111 1111 1111. One LSB is equal to 1 mV (4.1V/4096 LSBs).

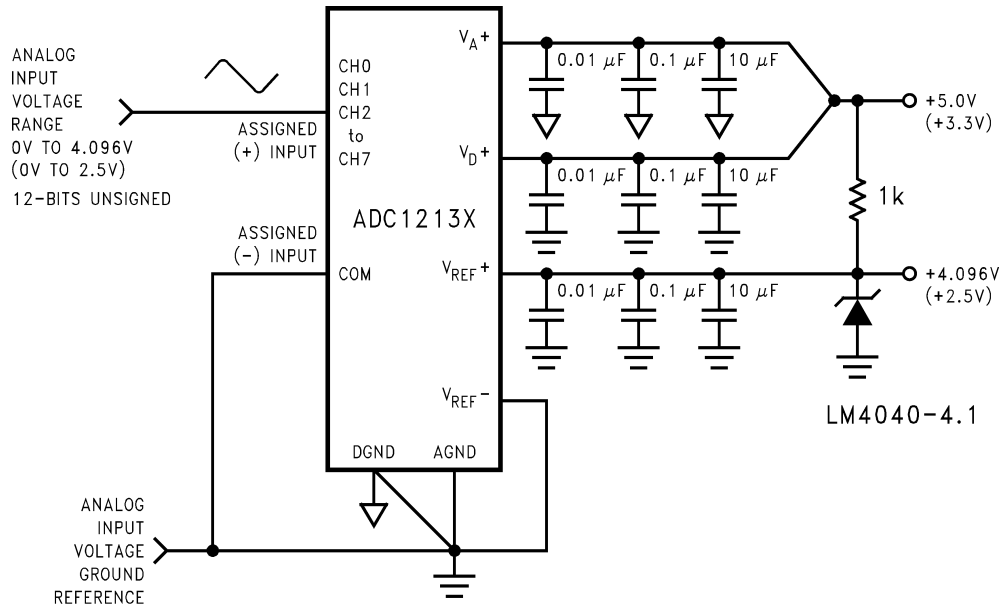

DS012079-38

FIGURE 11. Single-Ended Biasing

For pseudo-differential signed operation, the biasing circuit shown in Figure 12 shows a signal AC coupled to the ADC. This gives a digital output range of  $-4096$  to  $+4095$ . With a 2.5V reference, as shown, 1 LSB is equal to  $610 \mu\text{V}$ . Although, the ADC is not production tested with a 2.5V reference, when  $V_{A+}$  and  $V_{D+}$  are +5.0V linearity error typically will not change more than 0.1 LSB (see the curves in the Typical Electrical Characteristics Section). With the ADC set

to an acquisition time of 10 clock periods, the input biasing resistor needs to be  $600\Omega$  or less. Notice though that the input coupling capacitor needs to be made fairly large to bring down the high pass corner. Increasing the acquisition time to 34 clock periods (with a 5 MHz CCLK frequency) would allow the  $600\Omega$  to increase to 6k, which with a  $1 \mu\text{F}$  coupling capacitor would set the high pass corner at 26 Hz. Increasing R, to 6k would allow  $R_2$  to be 2k.

Application Hints (Continued)

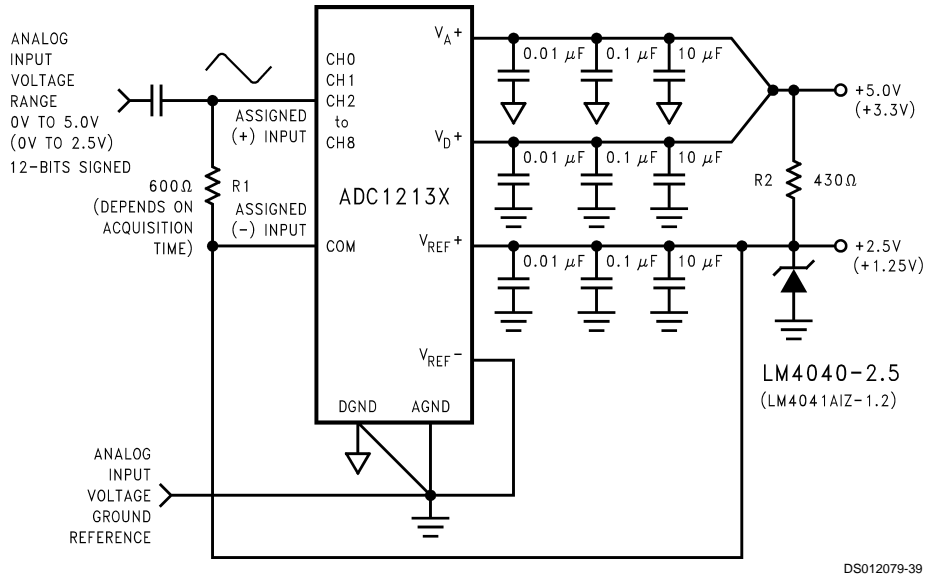

DS012079-39

FIGURE 12. Pseudo-Differential Biasing with the Signal Source AC Coupled Directly into the ADC

An alternative method for biasing pseudo-differential operation is to use the +2.5V from the LM4040 to bias any amplifier circuits driving the ADC as shown in Figure 13. The value of the resistor pull-up biasing the LM4040-2.5 will depend upon the current required by the op amp biasing circuitry.

In the circuit of Figure 13 some voltage range is lost since the amplifier will not be able to swing to +5V and GND with a single +5V supply. Using an adjustable version of the

LM4041 to set the full scale voltage at exactly 2.048V and a lower grade LM4040D-2.5 to bias everything to 2.5V as shown in Figure 14 will allow the use of all the ADC's digital output range of -4096 to +4095 while leaving plenty of head room for the amplifier.

Fully differential operation is shown in Figure 15. One LSB for this case is equal to  $(4.1V/4096) = 1 \text{ mV}$ .

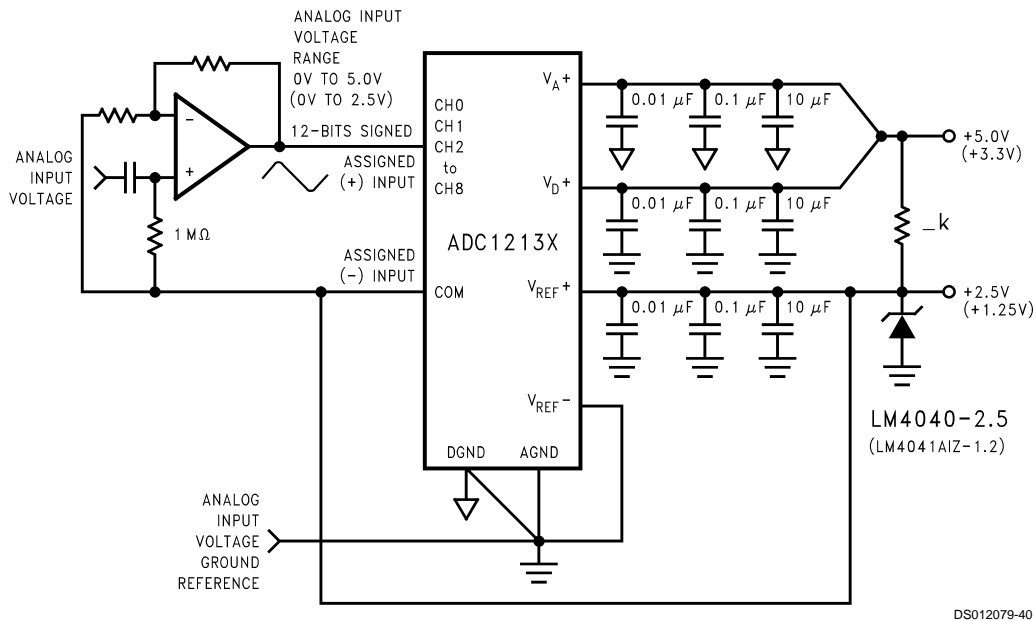

DS012079-40

FIGURE 13. Alternative Pseudo-Differential Biasing

Application Hints (Continued)

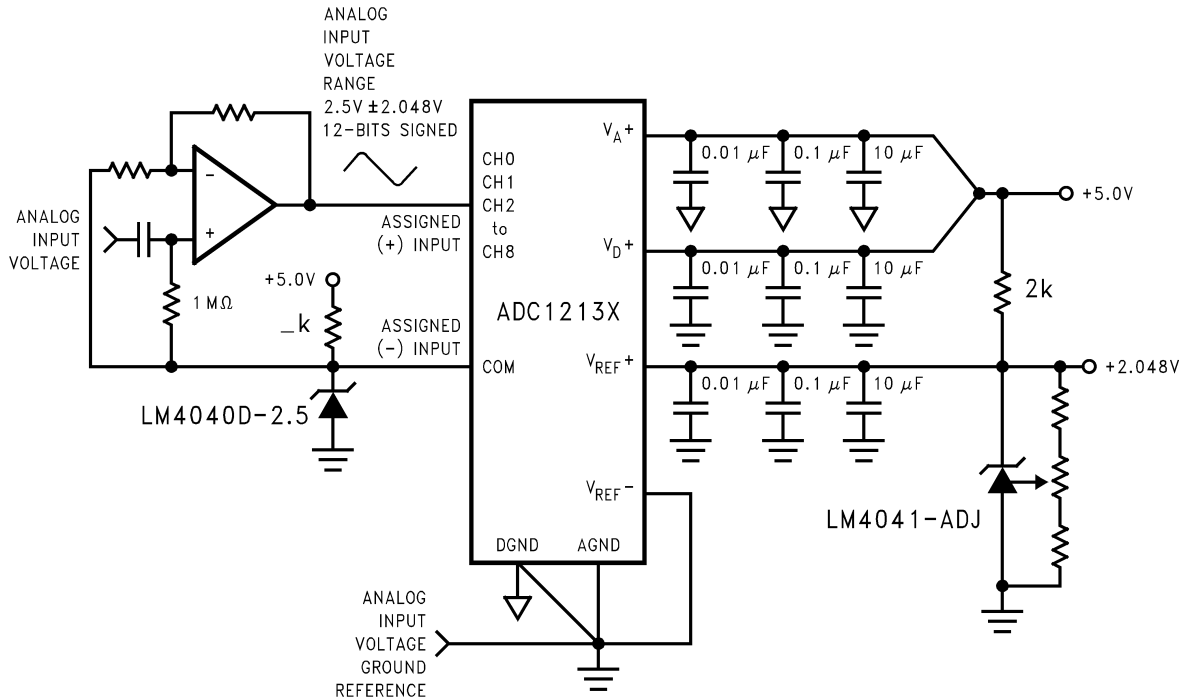

DS012079-41

FIGURE 14. Pseudo-Differential Biasing without the Loss of Digital Output Range

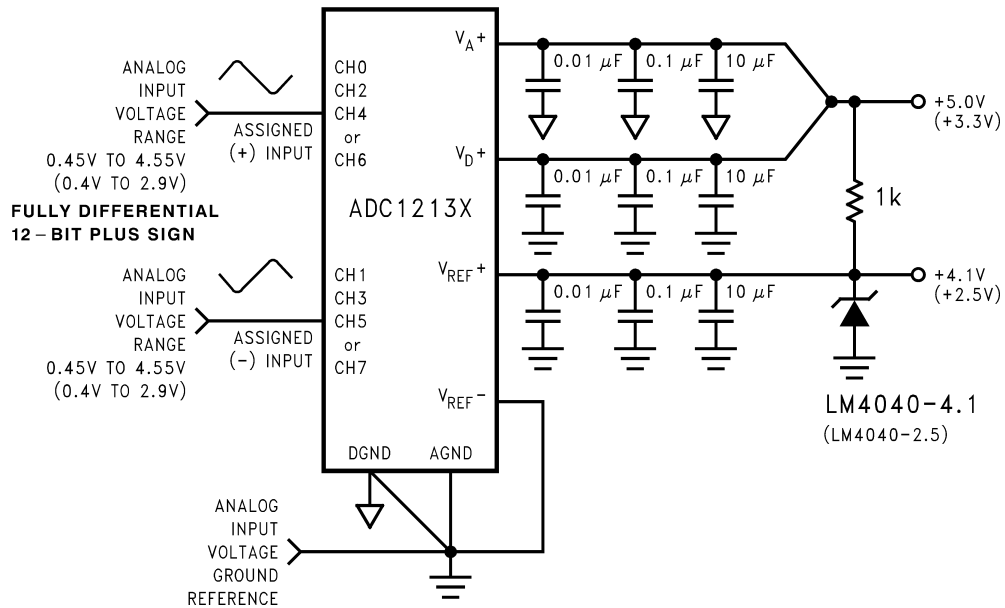

DS012079-42

FIGURE 15. Fully Differential Biasing

3.0 REFERENCE VOLTAGE

The difference in the voltages applied to the  $V_{REF+}$  and  $V_{REF-}$  defines the analog input span (the difference between the voltage applied between two multiplexer inputs or the voltage applied to one of the multiplexer inputs and analog ground), over which 4095 positive and 4096 negative codes exist. The voltage sources driving  $V_{REF+}$  or  $V_{REF-}$  must have

very low output impedance and noise. The circuit in *Figure 16* is an example of a very stable reference appropriate for use with the device.

## Application Hints (Continued)

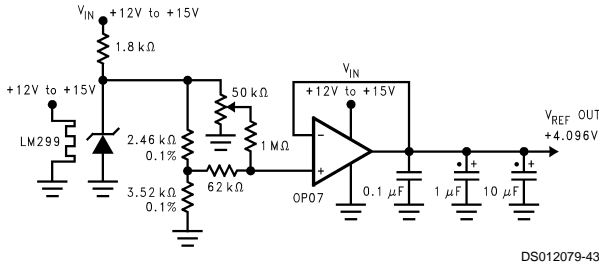

\*Tantalum

**FIGURE 16. Low Drift Extremely Stable Reference Circuit**

The ADC12130/2/8 can be used in either ratiometric or absolute reference applications. In ratiometric systems, the analog input voltage is proportional to the voltage used for the ADC's reference voltage. When this voltage is the system power supply, the  $V_{REF+}$  pin is connected to  $V_{A+}$  and  $V_{REF-}$  is connected to ground. This technique relaxes the system reference stability requirements because the analog input voltage and the ADC reference voltage move together. This maintains the same output code for given input conditions. For absolute accuracy, where the analog input voltage varies between very specific voltage limits, a time and temperature stable voltage source can be connected to the reference inputs. Typically, the reference voltage's magnitude will require an initial adjustment to null reference voltage induced full-scale errors.

Below are recommended references along with some key specifications.

| Part Number          | Output Voltage Tolerance | Temperature Coefficient |
|----------------------|--------------------------|-------------------------|
| LM4041CI-Adj         | ±0.5%                    | ±100ppm/°C              |
| LM4040AI-4.1         | ±0.1%                    | ±100ppm/°C              |
| Circuit of Figure 16 | Adjustable               | ±2ppm/°C                |

The reference voltage inputs are not fully differential. The ADC12130/2/8 will not generate correct conversions or comparisons if  $V_{REF+}$  is taken below  $V_{REF-}$ . Correct conversions result when  $V_{REF+}$  and  $V_{REF-}$  differ by 1V and remain, at all times, between ground and  $V_{A+}$ . The  $V_{REF}$  common mode range,  $(V_{REF+} + V_{REF-})/2$  is restricted to  $(0.1 \times V_{A+})$  to  $(0.6 \times V_{A+})$ . Therefore, with  $V_{A+} = 5V$  the center of the reference ladder should not go below 0.5V or above 3.0V. Figure 17 is a graphic representation of the voltage restrictions on  $V_{REF+}$  and  $V_{REF-}$ .

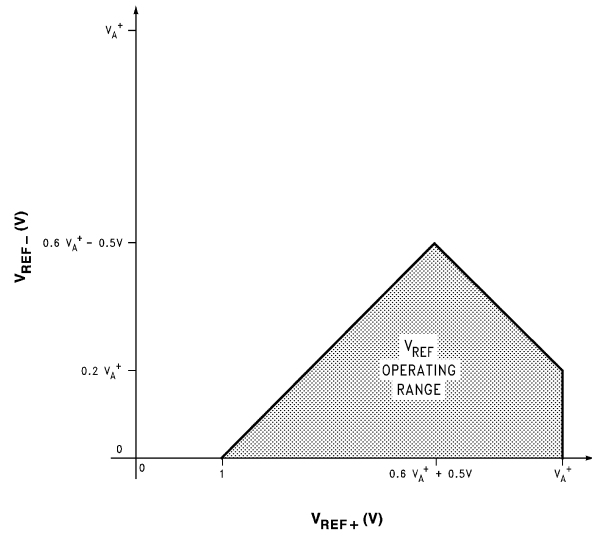

**FIGURE 17.  $V_{REF}$  Operating Range**

### 4.0 ANALOG INPUT VOLTAGE RANGE

The ADC12130/2/8's fully differential ADC generate a two's complement output that is found by using the equation shown below:

for (12-bit) resolution the Output Code =

$$\frac{(V_{IN+} - V_{IN-}) (4096)}{(V_{REF+} - V_{REF-})}$$

Round off to the nearest integer value between -4096 to 4095 if the result of the above equation is not a whole number.

Examples are shown in the table below:

| $V_{REF+}$ | $V_{REF-}$ | $V_{IN+}$ | $V_{IN-}$ | Digital Output Code |
|------------|------------|-----------|-----------|---------------------|
| +2.5V      | +1V        | +1.5V     | 0V        | 0,1111,1111,1111    |
| +4.096V    | 0V         | +3V       | 0V        | 0,1011,1011,1000    |
| +4.096V    | 0V         | +2.499V   | +2.500V   | 1,1111,1111,1111    |
| +4.096V    | 0V         | 0V        | +4.096V   | 1,0000,0000,0000    |

### 5.0 INPUT CURRENT

At the start of the acquisition window ( $t_A$ ) a charging current flows into or out of the analog input pins (A/DIN1 and A/DIN2) depending on the input voltage polarity. The analog input pins are CH0-CH7 and COM when A/DIN1 is tied to MUXOUT1 and A/DIN2 is tied to MUXOUT2. The peak value of this input current will depend on the actual input voltage applied, the source impedance and the internal multiplexer switch on resistance. With MUXOUT1 tied to A/DIN1 and MUXOUT2 tied to A/DIN2 the internal multiplexer switch on resistance is typically 1.6 kΩ. The A/DIN1 and A/DIN2 mux on resistance is typically 750Ω.

### 6.0 INPUT SOURCE RESISTANCE

For low impedance voltage sources (<600Ω), the input charging current will decay, before the end of the S/H's acquisition time of 2 μs (10 CCLK periods with  $f_{CK} = 5$  MHz), to a value that will not introduce any conversion errors. For high source impedances, the S/H's acquisition time can be in-

## Application Hints (Continued)

creased to 18 or 34 CCLK periods. For less ADC accuracy and/or slower CCLK frequencies the S/H's acquisition time may be decreased to 6 CCLK periods. To determine the number of clock periods ( $N_c$ ) required for the acquisition time with a specific source impedance for the various resolutions the following equations can be used:

$$12 \text{ Bit} + \text{Sign} \quad N_C = [R_S + 2.3] \times f_{CK} \times 0.824$$

Where  $f_{CK}$  is the conversion clock (CCLK) frequency in MHz and  $R_S$  is the external source resistance in  $k\Omega$ . As an example, operating with a resolution of 12 Bits+sign, a 5 MHz clock frequency and maximum acquisition time of 34 conversion clock periods the ADC's analog inputs can handle a source impedance as high as 6  $k\Omega$ . The acquisition time may also be extended to compensate for the settling or response time of external circuitry connected between the MUXOUT and A/DIN pins.

The acquisition time  $t_A$  is started by a falling edge of SCLK and ended by a rising edge of CCLK (see timing diagrams). If SCLK and CCLK are asynchronous one extra CCLK clock period may be inserted into the programmed acquisition time for synchronization. Therefore with asynchronous SCLK and CCLKs the acquisition time will change from conversion to conversion.

### 7.0 INPUT BYPASS CAPACITANCE

External capacitors (0.01  $\mu\text{F}$ –0.1  $\mu\text{F}$ ) can be connected between the analog input pins, CH0–CH7, and analog ground to filter any noise caused by inductive pickup associated with long input leads. These capacitors will not degrade the conversion accuracy.

### 8.0 NOISE

The leads to each of the analog multiplexer input pins should be kept as short as possible. This will minimize input noise and clock frequency coupling that can cause conversion errors. Input filtering can be used to reduce the effects of the noise sources.

### 9.0 POWER SUPPLIES

Noise spikes on the  $V_A^+$  and  $V_D^+$  supply lines can cause conversion errors; the comparator will respond to the noise. The ADC is especially sensitive to any power supply spikes that occur during the auto-zero or linearity correction. The minimum power supply bypassing capacitors recommended are low inductance tantalum capacitors of 10  $\mu\text{F}$  or greater paralleled with 0.1  $\mu\text{F}$  monolithic ceramic capacitors. More or different bypassing may be necessary depending on the overall system requirements. Separate bypass capacitors should be used for the  $V_A^+$  and  $V_D^+$  supplies and placed as close as possible to these pins.

### 10.0 GROUNDING

The ADC12130/2/8's performance can be maximized through proper grounding techniques. These include the use of separate analog and digital ground planes. The digital ground plane is placed under all components that handle digital signals, while the analog ground plane is placed under all components that handle analog signals. The digital and analog ground planes are connected together at only one point, either the power supply ground or at the pins of the ADC. This greatly reduces the occurrence of ground loops and noise.

Shown in *Figure 18* is the ideal ground plane layout for the ADC12138 along with ideal placement of the bypass capacitors. The circuit board layout shown in *Figure 18* uses three bypass capacitors: 0.01  $\mu\text{F}$  (C1) and 0.1  $\mu\text{F}$  (C2) surface mount capacitors and 10  $\mu\text{F}$  (C3) tantalum capacitor.

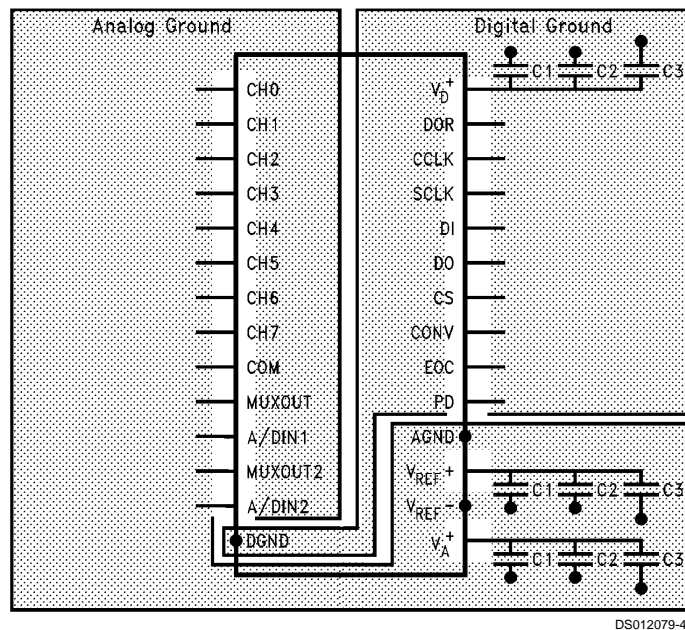

DS012079-45

FIGURE 18. Ideal Ground Plane

## Application Hints (Continued)

### 11.0 CLOCK SIGNAL LINE ISOLATION

The ADC12130/2/8's performance is optimized by routing the analog input/output and reference signal conductors as far as possible from the conductors that carry the clock signals to the CCLK and SCLK pins. Ground traces parallel to the clock signal traces can be used on printed circuit boards to reduce clock signal interference on the analog input/output pins.

### 12.0 THE CALIBRATION CYCLE

A calibration cycle needs to be started after the power supplies, reference, and clock have been given enough time to stabilize after initial turn-on. During the calibration cycle, correction values are determined for the offset voltage of the sampled data comparator and any linearity and gain errors. These values are stored in internal RAM and used during an analog-to-digital conversion to bring the overall full-scale, offset, and linearity errors down to the specified limits. Full-scale error typically changes  $\pm 0.4$  LSB over temperature and linearity error changes even less; therefore it should be necessary to go through the calibration cycle only once after power up if the Power Supply Voltage and the ambient temperature do not change significantly (see the curves in the Typical Performance Characteristics).

### 13.0 THE AUTO-ZERO CYCLE

To correct for any change in the zero (offset) error of the A/D, the auto-zero cycle can be used. It may be necessary to do an auto-zero cycle whenever the ambient temperature or the power supply voltage change significantly. (See the curves titled "Zero Error Change vs Ambient Temperature" and "Zero Error Change vs Supply Voltage" in the Typical Performance Characteristics.)

### 14.0 DYNAMIC PERFORMANCE

Many applications require the A/D converter to digitize AC signals, but the standard DC integral and differential nonlinearity specifications will not accurately predict the A/D converter's performance with AC input signals. The important specifications for AC applications reflect the converter's ability to digitize AC signals without significant spectral errors and without adding noise to the digitized signal. Dynamic

characteristics such as signal-to-noise (S/N), signal-to-noise + distortion ratio (S/(N + D)), effective bits, full power bandwidth, aperture time and aperture jitter are quantitative measures of the A/D converter's capability.

An A/D converter's AC performance can be measured using Fast Fourier Transform (FFT) methods. A sinusoidal waveform is applied to the A/D converter's input, and the transform is then performed on the digitized waveform. S/(N + D) and S/N are calculated from the resulting FFT data, and a spectral plot may also be obtained. Typical values for S/N are shown in the table of Electrical Characteristics, and spectral plots of S/(N + D) are included in the typical performance curves.

The A/D converter's noise and distortion levels will change with the frequency of the input signal, with more distortion and noise occurring at higher signal frequencies. This can be seen in the S/(N + D) versus frequency curves. These curves will also give an indication of the full power bandwidth (the frequency at which the S/(N + D) or S/N drops 3 dB).

Effective number of bits can also be useful in describing the A/D's noise performance. An ideal A/D converter will have some amount of quantization noise, determined by its resolution, which will yield an optimum S/N ratio given by the following equation:

$$S/N = (6.02 \times n + 1.76) \text{ dB}$$

where n is the A/D's resolution in bits.

The effective bits of a real A/D converter, therefore, can be found by:

$$n(\text{effective}) = \frac{S/N(\text{dB}) - 1.76}{6.02}$$

As an example, this device with a differential signed 5V, 10 kHz sine wave input signal will typically have a S/N of 78 dB, which is equivalent to 12.6 effective bits.

### 15.0 AN RS232 SERIAL INTERFACE

Shown on the following page is a schematic for an RS232 interface to any IBM and compatible PCs. The DTR, RTS, and CTS RS232 signal lines are buffered via level translators and connected to the ADC12138's DI, SCLK, and DO pins, respectively. The D flip/flop is used to generate the CS signal.

## Application Hints (Continued)

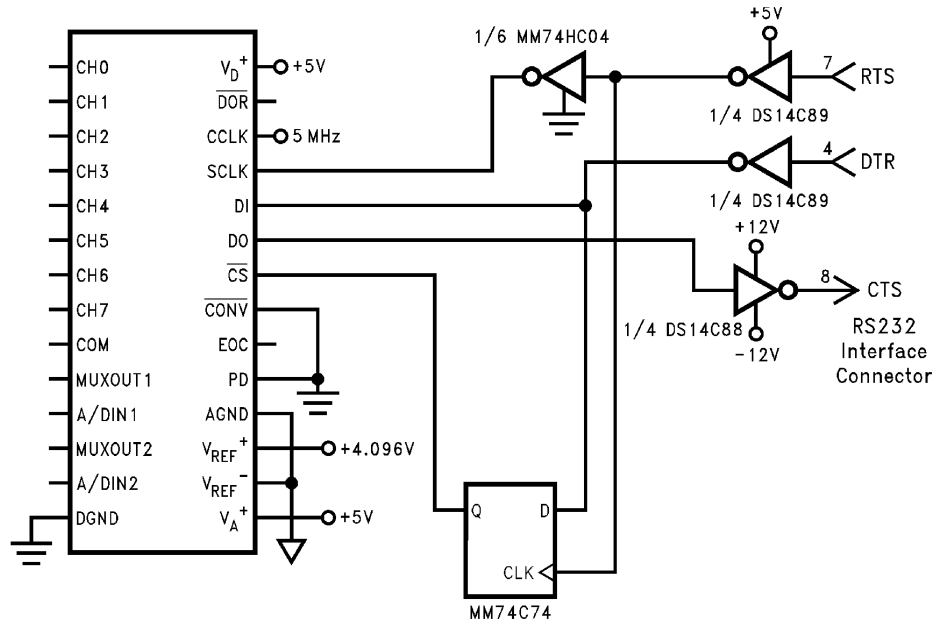

DS012079-46

**Note:**  $V_A^+$ ,  $V_D^+$ , and  $V_{REF}^+$  on the ADC12138 each have 0.01  $\mu$ F and 0.1  $\mu$ F chip caps, and 10  $\mu$ F tantalum caps. All logic devices are bypassed with 0.1  $\mu$ F caps.

The assignment of the RS232 port is shown below

|      |                |     | B7 | B6 | B5 | B4  | B3 | B2 | B1  | B0  |
|------|----------------|-----|----|----|----|-----|----|----|-----|-----|
| COM1 | Input Address  | 3FE | X  | X  | X  | CTS | X  | X  | X   | X   |
|      | Output Address | 3FC | X  | X  | X  | 0   | X  | X  | RTS | DTR |

A sample program, written in Microsoft QuickBasic, is shown on the next page. The program prompts for data mode select instruction to be sent to the A/D. This can be found from the Mode Programming table shown earlier. The data should be entered in "1"s and "0"s as shown in the table with DI0 first. Next the program prompts for the number of SCLKs required for the programmed mode select instruction. For instance, to send all "0"s to the A/D, selects CH0 as the +input, CH1 as the -input, 12-bit conversion, and 13-bit MSB first data output format (if the sign bit was not turned off by a previous instruction). This would require 13 SCLK periods since the output data format is 13 bits. The part powers up with No Auto Cal, No Auto Zero, 10 CCLK Acquisition Time, 12-bit conver-

sion, data out with sign, power up, 12- or 13-bit MSB First, and user mode. Auto Cal, Auto Zero, Power Up and Power Down instructions do not change these default settings. Since there is no  $\overline{CS}$  signal to synchronize the serial interface the following power up sequence should be followed:

1. Run the program
2. Prior to responding to the prompt apply the power to the ADC12138
3. Respond to the program prompts

It is recommended that the first instruction issued to the ADC12138 be Auto Cal (see Section 1.1).

### Code Listing:

```
'variables DOL=Data Out word length, DI=Data string for A/D DI input,
'          DO=A/D result string
'SET CS# HIGH
OUT <&H3FC, (<&H2 OR INP (<&H3FC)) 'set RTS
HIGH
OUT <&H3FC, (<&HFE AND INP(<&H3FC)) 'SET DTR LOW
OUT <&H3FC, (<&HFD AND INP (<&H3FC)) 'SET RTS LOW
OUT <&H3FC, (<&HEF AND INP(<&H3FC)) 'set B4 low
10
LINE INPUT <ldquo>DI data for ADC12138 (see Mode Table on data sheet)&rdquo;> DI$
INPUT <ldquo>ADC12138 output word length (12,13,16 or 17)&rdquo;> DOL
20
'SET CS# HIGH
OUT <&H3FC, (<&H2 OR INP (<&H3FC)) 'set RTS
HIGH
OUT <&H3FC, (<&HFE AND INP(<&H3FC)) 'SET DTR LOW
OUT <&H3FC, (<&HFD AND INP (<&H3FC)) 'SET RTS LOW
```

**Application Hints** (Continued)

```

'SET CS# LOW
OUT <H3FC, (<H2 OR INP (<H3FC)                                'set RTS
HIGH
OUT <H3FC, (<H1 OR INP(<H3FC)                                'SET DTR
HIGH
OUT <H3FC, (<HFD AND INP (<H3FC)                            'SET RTS LOW
DO$=<ldquo><rdquo> <rdquo>                                     'reset DO
variable
    OUT <H3FC, (<H1 OR INP(<H3FC)                            'SET DTR
HIGH
    OUT <H3FC, (<HFD AND INP(<H3FC))                          'SCLK low
FOR N = 1 TO 8
    Temp$ = MID$(DI$, N, 1)
    IF Temp$=<ldquo>0<rdquo> THEN
        OUT <H3FC, (<H1 OR INP(<H3FC))
    ELSE OUT <H3FC, (<HFE AND INP(<H3FC))
    END IF
    OUT <H3FC, (<H2 OR INP(<H3FC))                            'out DI
    IF (INP(<H3FE) AND 16) = 16 THEN                          'SCLK high
        DO$ = DO$ + <ldquo>0<rdquo>
    ELSE
        DO$ = DO$ + <ldquo>1<rdquo>
    END IF
    OUT <H3FC, (<H1 OR INP(<H3FC)                            'Input DO
    'SET DTR
HIGH
    OUT <H3FC, (<HFD AND INP(<H3FC))                          'SCLK low
NEXT N
IF DOL > 8 THEN
    FOR N=9 TO DOL
        OUT <H3FC, (<H1 OR INP(<H3FC)                        'SET DTR
HIGH
        OUT <H3FC, (<HFD AND INP(<H3FC))                    'SCLK low
        OUT <H3FC, (<H2 OR INP(<H3FC))                      'SCLK high
        IF (INP(<H3FE) AND <H10) = <H10 THEN
            DO$ = DO$ + <ldquo>0<rdquo>
        ELSE
            DO$ = DO$ + <ldquo>1<rdquo>
        END IF
    NEXT N
END IF
OUT <H3FC, (<HFA AND INP(<H3FC))                              'SCLK low
and DI high
FOR N = 1 TO 500
NEXT N
PRINT DO$
INPUT <ldquo>Enter <ldquo>C<rdquo> to convert else <ldquo>RETURN<rdquo> to alter DI
data<rdquo>; s$
IF s$ = <ldquo>C<rdquo> OR s$ = <ldquo>c<rdquo> THEN
GOTO 20
ELSE
GOTO 10
END IF
END

```

**Physical Dimensions** inches (millimeters) unless otherwise noted

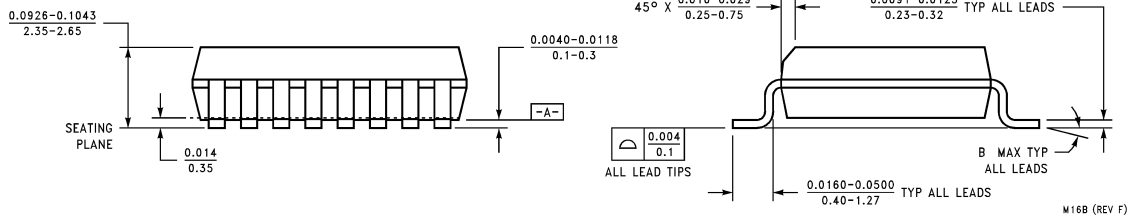
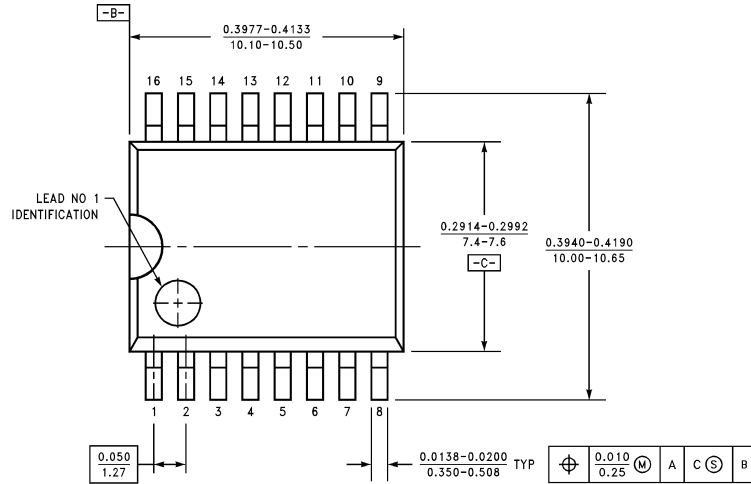

**Order Number ADC12130CIWM  
NS Package Number M16B**

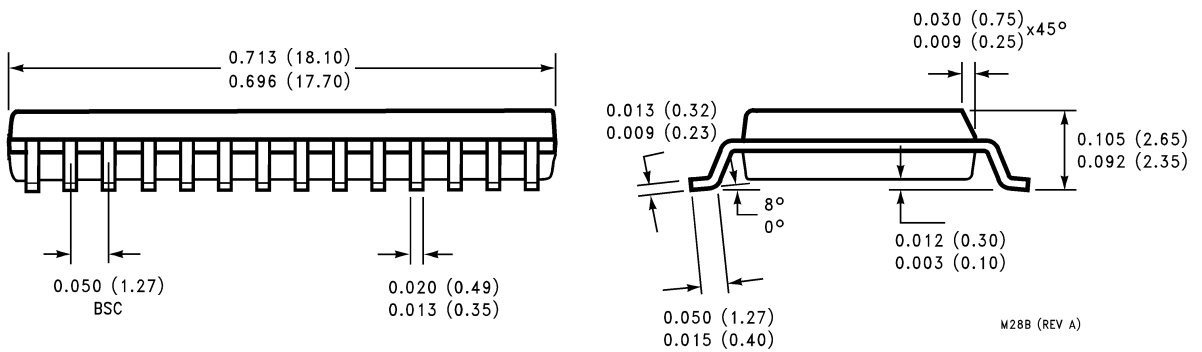
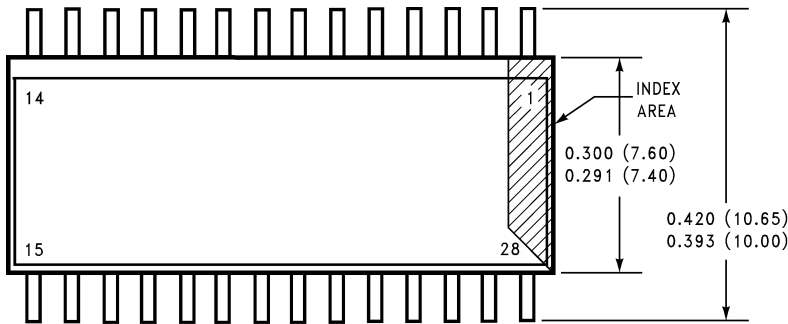

**Order Number ADC12138CIWM  
NS Package Number M28B**

**Physical Dimensions** inches (millimeters) unless otherwise noted (Continued)

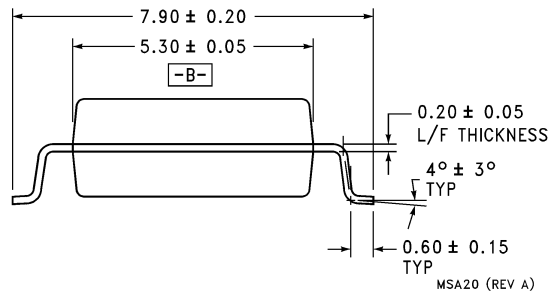
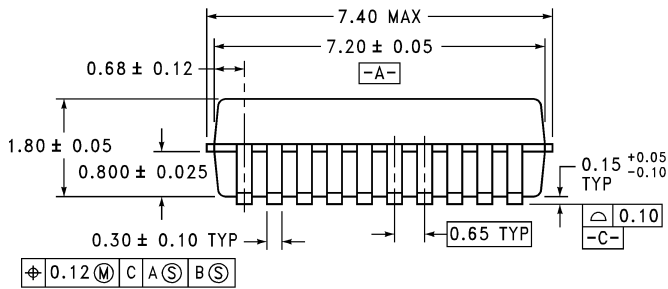
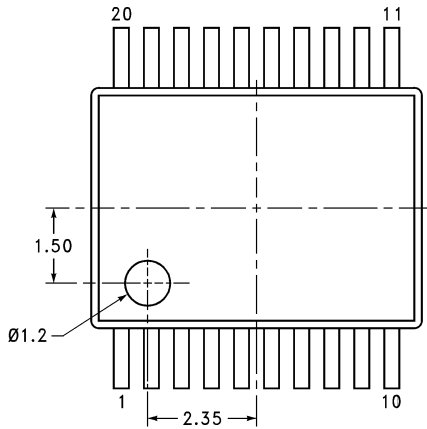

**Order Number ADC12132CIMS**  
**NS Package Number MSA20**

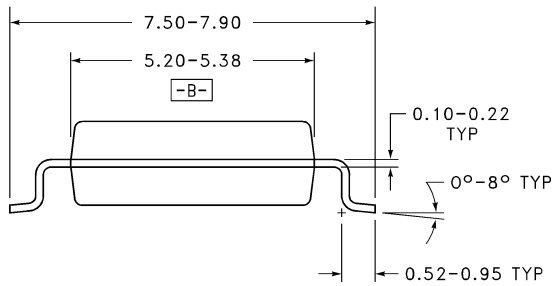
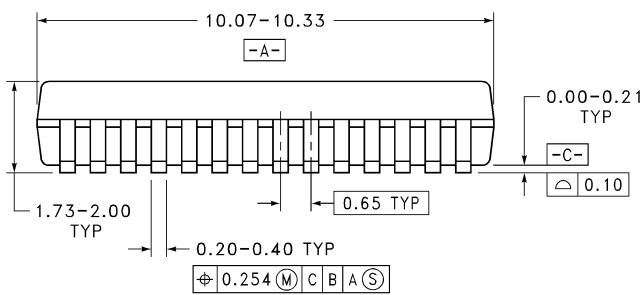
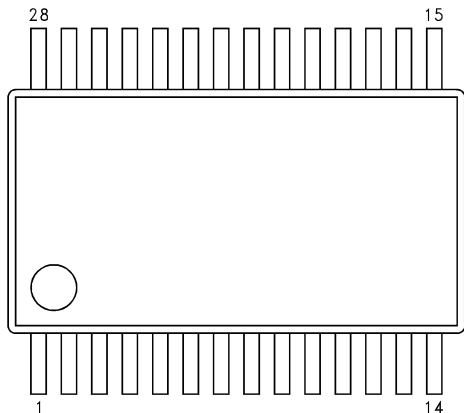

**Order Number ADC12138CIMS**  
**NS Package Number MSA28**

**Physical Dimensions** inches (millimeters) unless otherwise noted (Continued)

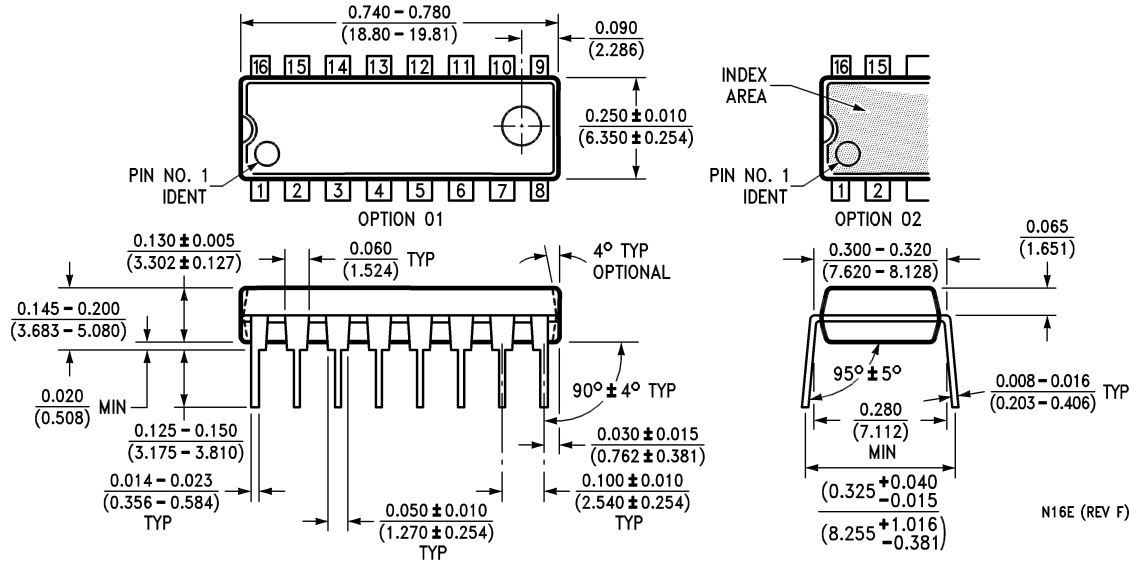

**Order Number ADC12130CIN**  
**NS Package Number N16E**

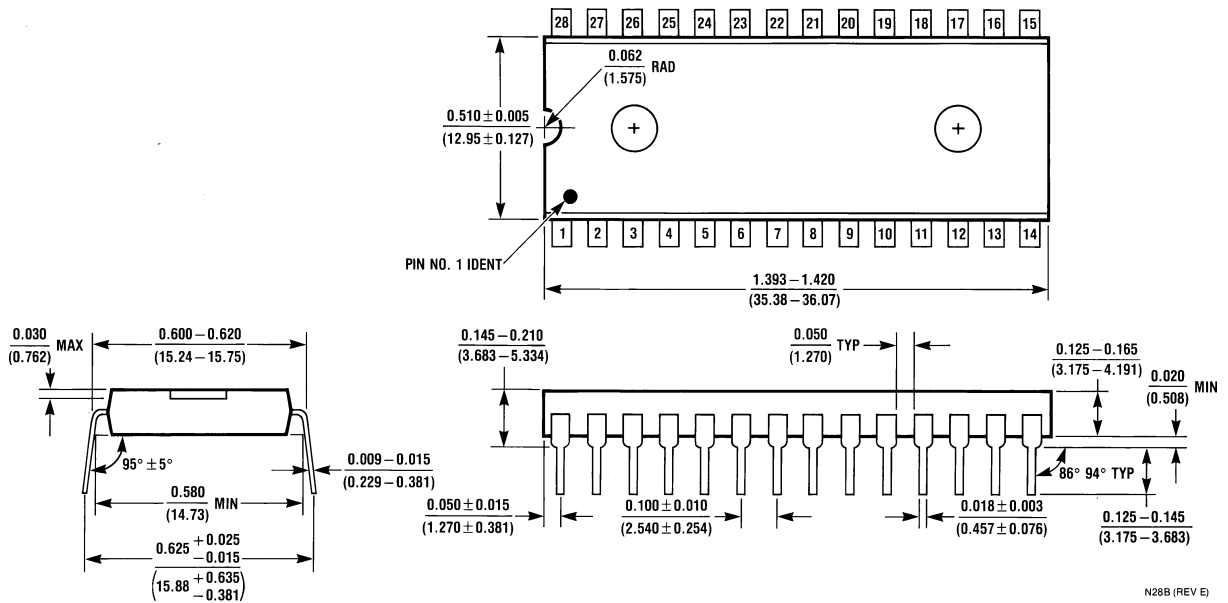

**Order Number ADC12138CIN**  
**NS Package Number N28B**

## Notes

### LIFE SUPPORT POLICY

NATIONAL'S PRODUCTS ARE NOT AUTHORIZED FOR USE AS CRITICAL COMPONENTS IN LIFE SUPPORT DEVICES OR SYSTEMS WITHOUT THE EXPRESS WRITTEN APPROVAL OF THE PRESIDENT AND GENERAL COUNSEL OF NATIONAL SEMICONDUCTOR CORPORATION. As used herein:

1. Life support devices or systems are devices or systems which, (a) are intended for surgical implant into the body, or (b) support or sustain life, and whose failure to perform when properly used in accordance with instructions for use provided in the labeling, can be reasonably expected to result in a significant injury to the user.
2. A critical component is any component of a life support device or system whose failure to perform can be reasonably expected to cause the failure of the life support device or system, or to affect its safety or effectiveness.



**National Semiconductor Corporation**  
 Americas  
 Tel: 1-800-272-9959  
 Fax: 1-800-737-7018  
 Email: support@nsc.com  
 www.national.com

**National Semiconductor Europe**  
 Fax: +49 (0) 180-530 85 86  
 Email: europe.support@nsc.com  
 Deutsch Tel: +49 (0) 69 9508 6208  
 English Tel: +44 (0) 870 24 0 2171  
 Français Tel: +33 (0) 1 41 91 8790

**National Semiconductor Asia Pacific Customer Response Group**  
 Tel: 65-2544466  
 Fax: 65-2504466  
 Email: ap.support@nsc.com

**National Semiconductor Japan Ltd.**  
 Tel: 81-3-5639-7560  
 Fax: 81-3-5639-7507

This datasheet has been downloaded from:

[www.DatasheetCatalog.com](http://www.DatasheetCatalog.com)

Datasheets for electronic components.

# National Semiconductor was acquired by Texas Instruments.

[http://www.ti.com/corp/docs/investor\\_relations/pr\\_09\\_23\\_2011\\_national\\_semiconductor.html](http://www.ti.com/corp/docs/investor_relations/pr_09_23_2011_national_semiconductor.html)

This file is the datasheet for the following electronic components:

ADC12138CIN - <http://www.ti.com/product/adc12138cin?HQS=TI-null-null-dscatalog-df-pf-null-ww>

ADC12130CIN - <http://www.ti.com/product/adc12130cin?HQS=TI-null-null-dscatalog-df-pf-null-ww>



LittleDiode supplies new, hard to find or obsolete electronic components and semiconductors all over the world.

With over two million different components listed you are sure to find the part you need.

Feel free to visit us today at our online store:

[LittleDiode.com](http://LittleDiode.com)

Looking forward to providing you with the best possible service.