

ADC71

16-Bit ANALOG-TO-DIGITAL CONVERTER

FEATURES

- 16-BIT RESOLUTION
- $\pm 0.003\%$ MAXIMUM NONLINEARITY
- COMPACT DESIGN: 32-pin Hermetic Ceramic Package
- CONVERSION SPEED: 50 μ s max

DESCRIPTION

The ADC71 is a low cost, high quality, 16-bit successive approximation analog-to-digital converter. It uses laser-trimmed ICs and is packaged in a convenient 32-pin hermetic ceramic dual-in-line package. The converter is complete with internal reference, clock, comparator, and thin-film scaling resistors, which allow selection of analog input ranges of $\pm 2.5V$, $\pm 5V$, $\pm 10V$, 0 to +5V, 0 to +10V and 0 to +20V.

Data is available in parallel and serial form with corresponding clock and status output. All digital inputs and outputs are TTL-compatible.

Power supply voltages are $\pm 15VDC$ and +5VDC.

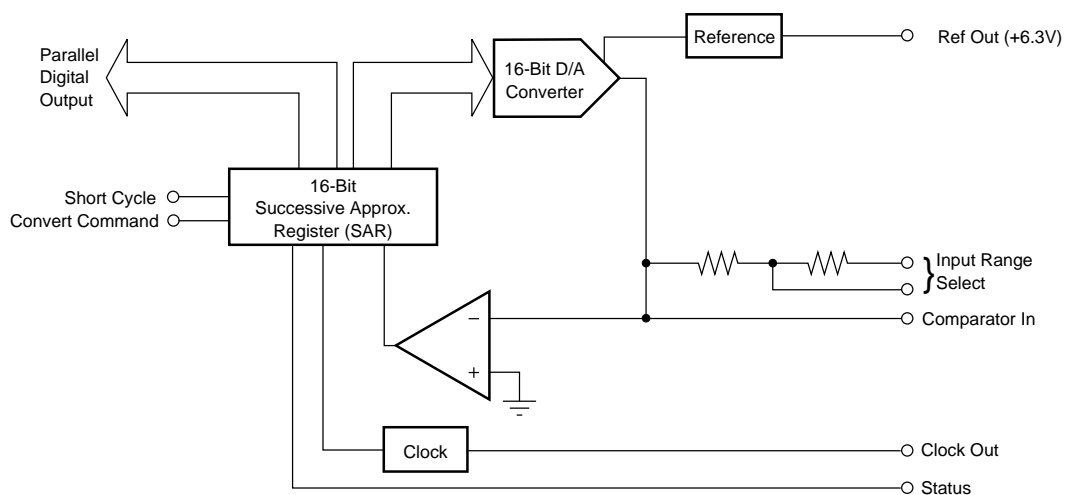

International Airport Industrial Park • Mailing Address: PO Box 11400 • Tucson, AZ 85734 • Street Address: 6730 S. Tucson Blvd. • Tucson, AZ 85706
Tel: (520) 746-1111 • Twx: 910-952-1111 • Cable: BBRCORP • Telex: 066-6491 • FAX: (520) 889-1510 • Immediate Product Info: (800) 548-6132

SPECIFICATIONS

ELECTRICAL

At +25°C and rated power supplies, unless otherwise noted.

MODEL	ADC71J, K			ADC71A, B			UNITS	
	MIN	TYP	MAX	MIN	TYP	MAX		
RESOLUTION			16			16	Bits	
INPUTS								
ANALOG								
Voltage Ranges: Bipolar		±2.5, ±5, ±10			±2.5, ±5, ±10		V	
Unipolar		0 to +5, 0 to +10, 0 to +20			0 to +5, 0 to +10, 0 to +20		V	
Input Impedance (Direct Input)								
0 to +5V, ±2.5V		2.5			2.5		kΩ	
0 to +10V, ±5.0V		5			5		kΩ	
0 to +20V, ±10V		10			10		kΩ	
DIGITAL⁽¹⁾								
Logic Loading		Convert Command Positive pulse 50ns wide (min) trailing edge ("1" to "0" initiates conversion)						TTL Load
TRANSFER CHARACTERISTICS								
ACCURACY								
Gain Error ⁽²⁾		±0.1	±0.2		±0.1	±0.2	%	
Offset ⁽²⁾ : Unipolar		±0.05	±0.1		±0.05	±0.1	% of FSR ⁽³⁾	
Bipolar		±0.1	±0.2		±0.1	±0.2	% of FSR	
Linearity Error: K, B			±0.003			±0.003	% of FSR	
J, A			±0.006			±0.006	% of FSR	
Inherent Quantization Error		±1/2			±1/2		LSB	
Differential Linearity Error		±0.003			±0.003		% of FSR	
POWER SUPPLY SENSITIVITY								
±15VDC		0.003			0.003		% of FSR/%V _S	
+5VDC		0.001			0.001		% of FSR/%V _S	
CONVERSION TIME⁽⁴⁾								
14 Bits			50			50	μs	
WARM-UP TIME	5			*			min	
DRIFT								
Gain		±10	±15		*	*	ppm/°C	
Offset: Unipolar		±2	±4			±2	ppm of FSR/°C	
Bipolar		±8	±10		±5	±10	ppm of FSR/°C	
Linearity		±2	±3			±2	ppm of FSR/°C	
No Missing Codes Temp Range								
J, A (13 Bits)	0		+70	-25		+85	°C	
K, B (14 Bits)	0		+70	-25		+85	°C	
OUTPUT								
DIGITAL DATA								
(All Codes Complementary)								
Parallel Output Codes ⁽⁵⁾ : Unipolar		CSB						
Bipolar		COB, CTC ⁽⁶⁾				*	TTL Loads	
Output Drive			2			*	TTL Loads	
Serial Data Code (NRZ)		CSB, COB				*	TTL Loads	
Output Drive			2				TTL Loads	
Status		Logic "1" During Conversion					TTL Loads	
Status Output Drive			2			2	TTL Loads	
Clock Output Drive			2			2	TTL Loads	
Frequency ⁽⁷⁾		280			*		kHz	
INTERNAL REFERENCE VOLTAGE	6.0	6.3	6.6	6.0	6.3	6.6	V	
Max External Current with								
No Degradation of Specs			±200			±200	μA	
Temp Coefficient			±10			*	ppm/°C	
POWER SUPPLY REQUIREMENTS								
Power Consumption		655			655		mW	
Rated Voltage, Analog	±11.4	±15	±16	*	*	*	VDC	
Rated Voltage, Digital	+4.75	+5	+4.75	*	*	*	VDC	
Supply Drain +15VDC		+10	+15		*	*	mA	
Supply Drain -15VDC		-28	-35		*	*	mA	
Supply Drain +5VDC		+17	+20		*	*	mA	
TEMPERATURE RANGE								
Specification	0		+70	-25		+85	°C	
Operating (Derated Specs)	-25		+85	-55		+125	°C	
Storage	-55		+125	-55		+125	°C	

NOTES: (1) CMOS/TTL compatible, i.e., Logic "0" = 0.8V, max Logic "1" = 2.0V, min for inputs. For digital outputs Logic "0" = +0.4V, max Logic "1" = 2.4V min. (2) Adjustable to zero. (3) FSR means Full Scale Range. For example, unit connected for ±10V range has 20V FSR. (4) Conversion time may be shortened with "Short Cycle" set for lower resolution, see "Additional Connections Required" section. (5) See Table I. CSB = Complementary Straight Binary. COB = Complementary Offset Binary. CTC = Complementary Two's Complement. (6) CTC coding obtained by inverting MSB (Pin 1).

PIN CONFIGURATION

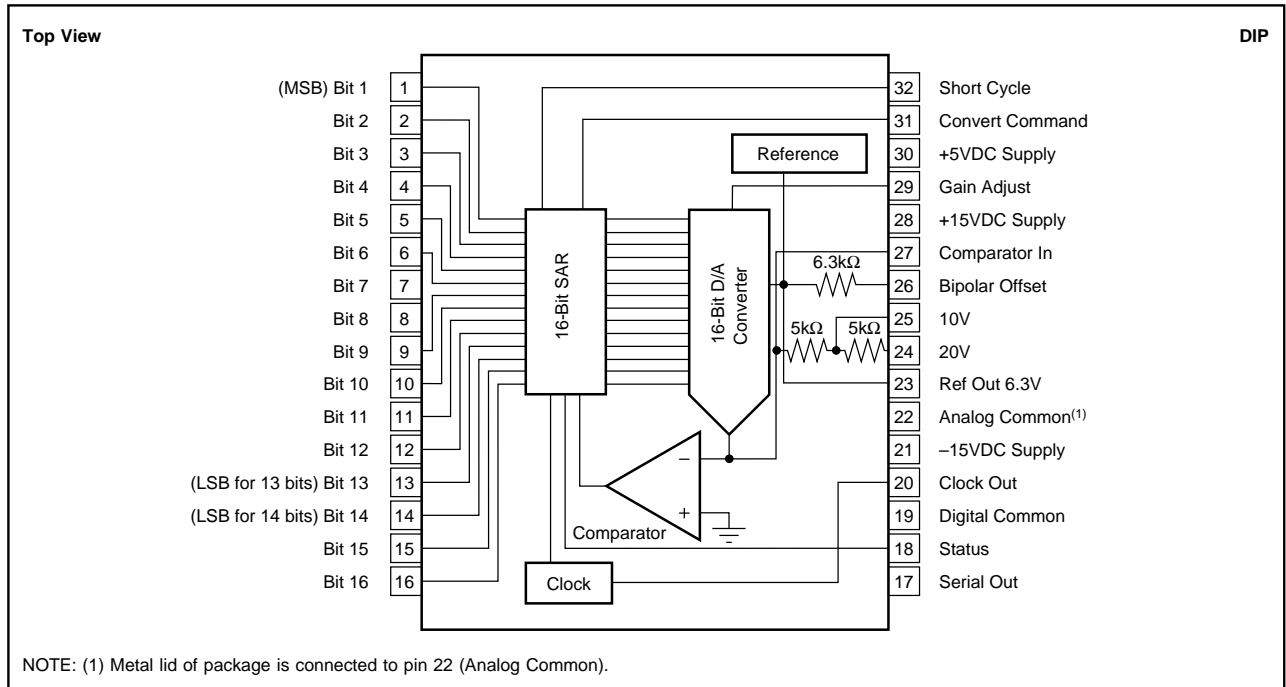

ABSOLUTE MAXIMUM SPECIFICATIONS

+V _{CC} to Common	0 to +16.5V
-V _{CC} to Common	0V to -16.5V
+V _{DD} to Common	0V to +7V
Analog Common to Digital Common	±0.5V
Logic Inputs to Common	0V to V _{DD}
Maximum Power Dissipation	1000mW
Lead Temperature (10s)	300°C

PACKAGE INFORMATION

MODEL	PACKAGE	PACKAGE DRAWING NUMBER ⁽¹⁾
ADC71JG	32-Pin Hermetic DIP	172-5
ADC71KG	32-Pin Hermetic DIP	172-5
ADC71AG	32-Pin Hermetic DIP	172-5
ADC71BG	32-Pin Hermetic DIP	172-5

NOTE: (1) For detailed drawing and dimension table, please see end of data sheet, or Appendix D of Burr-Brown IC Data Book.

ORDERING INFORMATION

MODEL	TEMPERATURE RANGE	NONLINEARITY
ADC71JG	0°C to +70°C	±0.006% FSR
ADC71KG	0°C to +70°C	±0.003% FSR
ADC71AG	-25°C to +85°C	±0.006% FSR
ADC71BG	-25°C to +85°C	±0.003% FSR

The information provided herein is believed to be reliable; however, BURR-BROWN assumes no responsibility for inaccuracies or omissions. BURR-BROWN assumes no responsibility for the use of this information, and all use of such information shall be entirely at the user's own risk. Prices and specifications are subject to change without notice. No patent rights or licenses to any of the circuits described herein are implied or granted to any third party. BURR-BROWN does not authorize or warrant any BURR-BROWN product for use in life support devices and/or systems.

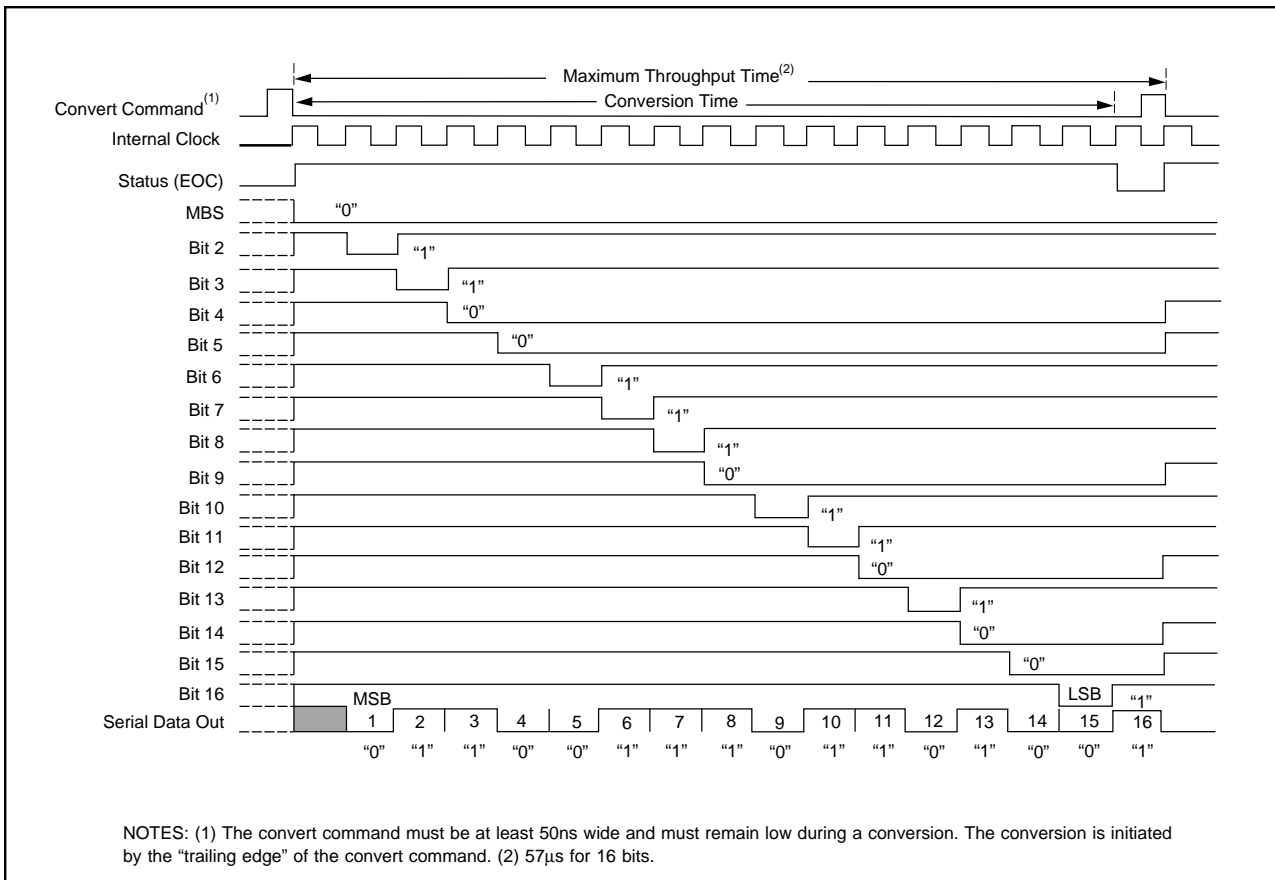

FIGURE 1. ADC71 Timing Diagram.

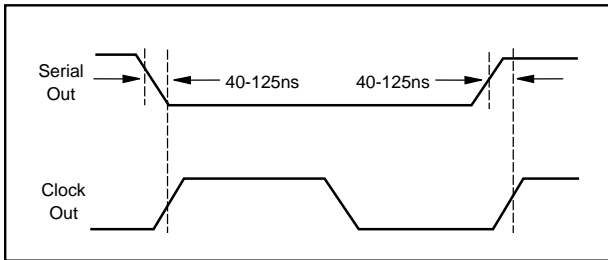

FIGURE 2. Timing Relationship of Serial Data to Clock.

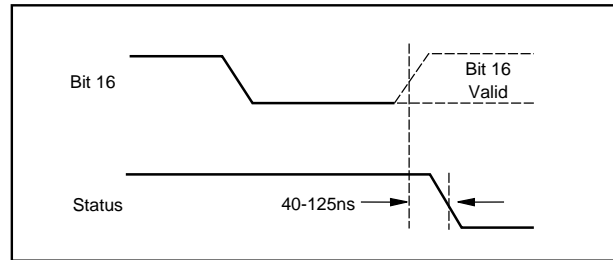

FIGURE 3. Timing Relationship of Valid Data to Status.

Binary (BIN) Output	INPUT VOLTAGE RANGE AND LSB VALUES						
	Defined As:	±10V	±5V	±2.5V	0 to +10V	0 to +5V	0 to +20V
Analog Input Voltage Range		±10V	±5V	±2.5V	0 to +10V	0 to +5V	0 to +20V
Code Designation		COB ⁽¹⁾ or CTC ⁽²⁾	COB ⁽¹⁾ or CTC ⁽²⁾	COB ⁽¹⁾ or CTC ⁽²⁾	CSB ⁽³⁾	CSB ⁽³⁾	CSB ⁽³⁾
One Least Significant Bit (LSB)	$\frac{FSR}{2^n}$ n = 12 n = 13 n = 14	$\frac{20V}{2^n}$ 4.88mV 2.44mV 1.22mV	$\frac{10V}{2^n}$ 2.44mV 1.22mV 610μV	$\frac{5V}{2^n}$ 1.22mV 610μV 305μV	$\frac{10V}{2^n}$ 2.44mV 1.22mV 610μV	$\frac{5V}{2^n}$ 1.22mV 610μV 305μV	$\frac{20V}{2^n}$ 4.88mV 2.44mV 1.22mV
Transition Values MSB LSB							
000 ... 000 ⁽⁴⁾	+Full Scale	+10V-3/2LSB	+5V-3/2LSB	+2.5V-3/2LSB	+10V-3/2LSB	+5V-3/2LSB	+20V-3/2LSB
011 ... 111	Mid Scale	0	0	0	+5V	+2.5V	+10V
111 ... 110	-Full Scale	-10V +1/2LSB	-5V +1/2LSB	-2.5V +1/2LSB	0 +1/2LSB	0 +1/2LSB	0 +1/2LSB

NOTES: (1) COB = Complementary Offset Binary. (2) Complementary Two's Complement—obtained by inverting the most significant bit MSB (pin 1). (3) CSB = Complementary Straight Binary. (4) Voltages given are the nominal value for transition to the code specified.

TABLE I. Input Voltages, Transition Values, LSB Values, and Code Definitions.

TYPICAL PERFORMANCE CURVES

At +25°C and rated power supplies unless otherwise noted.

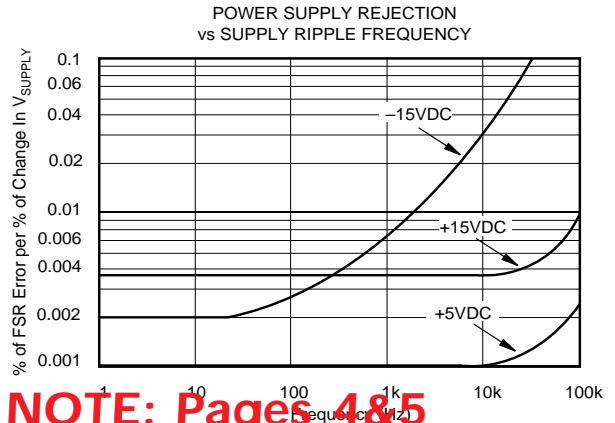
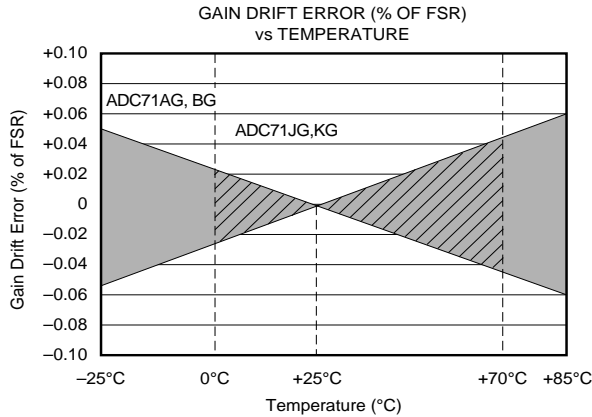

NOTE: Pages 4&5 were switched for Abridged Version for '96 data book.

DISCUSSION OF PERFORMANCE

The accuracy of a successive approximation A/D converter is described by the transfer function shown in Figure 1. All successive approximation A/D converters have an inherent Quantization Error of $\pm 1/2$ LSB. The remaining errors in the A/D converter are combinations of analog errors due to the linear circuitry, matching and tracking properties of the ladder and scaling networks, power supply rejection, and reference errors. In summary, these errors consist of initial errors including Gain, Offset, Linearity, Differential Linearity, and Power Supply Sensitivity. Initial Gain and Offset errors may be adjusted to zero. Gain drift over temperature rotates the line (Figure 1) about the zero or minus full scale point (all bits Off) and Offset drift shifts the line left or right over the operating temperature range. Linearity error is unadjustable and is the most meaningful indicator of A/D

converter accuracy. Linearity error is the deviation of an actual bit transition from the ideal transition value at any level over the range of the A/D converter. A Differential Linearity error of $\pm 1/2$ LSB means that the width of each bit step over the range of the A/D converter is 1 LSB, $\pm 1/2$ LSB. The ADC71 is monotonic, assuring that the output digital code either increases or remains the same for increasing analog input signals. Burr-Brown guarantees that these converters will have no missing codes over a specified temperature range when short-cycled for 14-bit operation.

TIMING CONSIDERATIONS

The timing diagram (Figure 2) assumes an analog input such that the positive true digital word 1001 1000 1001 0110 exists. The output will be complementary as shown in Figure 2 (0110 0111 0110 1001 is the digital output). Figures 3 and 4 are timing diagrams showing the relationship of serial data to clock and valid data to status.

DEFINITION OF DIGITAL CODES

Parallel Data

Two binary codes are available on the ADC71 parallel output; they are complementary (logic "0" is true) straight binary (CSB) for unipolar input signal ranges and complementary offset binary (COB) for bipolar input signal ranges. Complementary two's complement (CTC) may be obtained by inverting MSB (Pin 1).

Table I shows the LSB, transition values, and code definitions for each possible analog input signal range for 12-, 13- and 14-bit resolutions. Figure 5 shows the connections for 14-bit resolution, parallel data output, with $\pm 10V$ input.

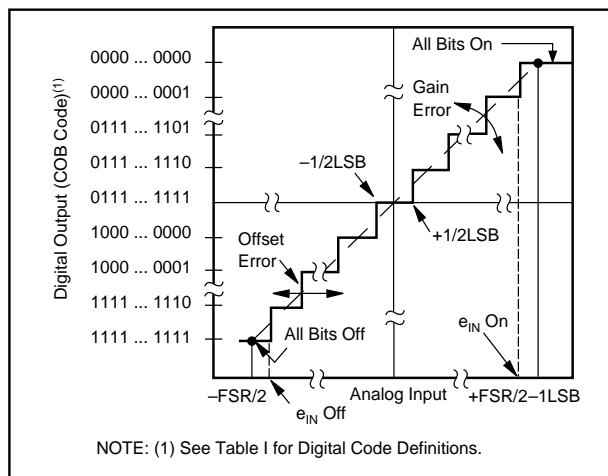

FIGURE 1. Input vs Output for an Ideal Bipolar A/D Converter.

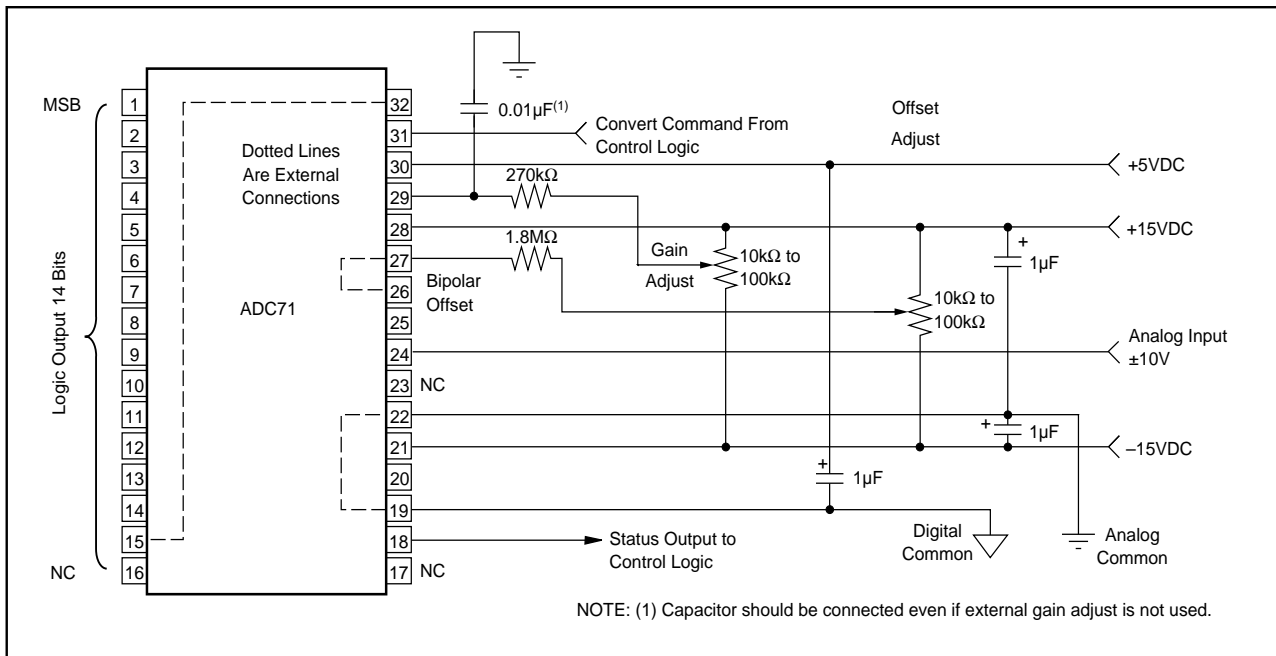

FIGURE 5. ADC71 Connections for: $\pm 10V$ Analog Input, 14-Bit Resolution (Short-Cycled), Parallel Data Output.

SERIAL DATA

Two straight binary (complementary) codes are available on the serial output line: CSB and COB. The serial data is available only during conversion and appears with MSB occurring first. The serial data is synchronous with the internal clock as shown in the timing diagrams of Figures 2 and 3. The LSB and transition values shown in Table I also apply to the serial data output except for the CTC code.

DISCUSSION OF SPECIFICATIONS

The ADC71 is specified to provide critical performance criteria for a wide variety of applications. The most critical specifications for an A/D converter are linearity, drift, gain and offset errors. This ADC is factory-trimmed and tested for all critical key specifications.

GAIN AND OFFSET ERROR

Initial Gain and Offset errors are factory-trimmed to typically $\pm 0.1\%$ of FSR (typically $\pm 0.05\%$ for unipolar offset) at 25°C . These errors may be trimmed to zero by connecting external trim potentiometers as shown in Figures 6 and 7.

POWER SUPPLY SENSITIVITY

Changes in the DC power supplies will affect accuracy. The power supply sensitivity is specified for $\pm 0.003\%$ of FSR/ $\% \Delta V_s$ for $\pm 15V$ supplies and $\pm 0.001\%$ of FSR/ $\% \Delta V_s$ for $+5V$ supplies. Normally, regulated power supplies with 1% or less ripple are recommended for use with this ADC. See Layout Precautions, Power Supply Decoupling and Figure 8.

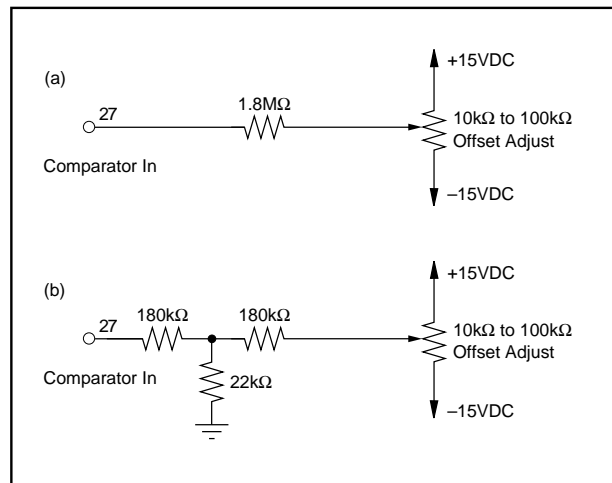

FIGURE 6. Two Methods of Connecting Optional Offset Adjust with a 0.4% of FSR of Adjustment.

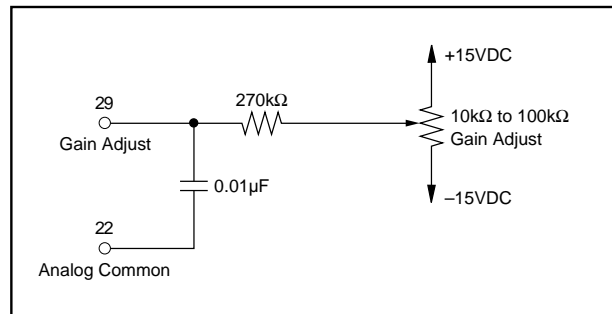

FIGURE 7. Connecting Optional Gain Adjust with a 0.2% Range of Adjustment.

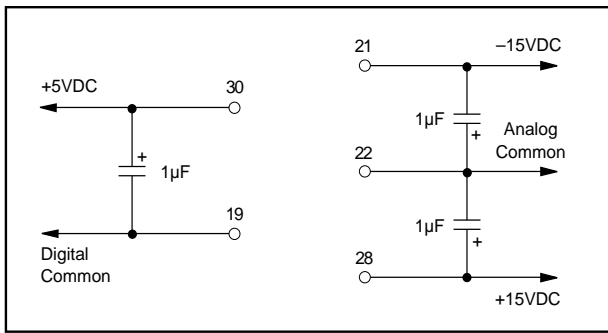

FIGURE 8. Recommended Power Supply Decoupling.

LAYOUT AND OPERATING INSTRUCTIONS

Layout Precautions

Analog and digital common are not connected internally in the ADC71 but should be connected together as close to the unit as possible, preferably to a large plane under the ADC. If these grounds must be run separately, use wide conductor patterns and a 0.01µF to 0.1µF non-polarized bypass capacitor between analog and digital commons at the unit. Low impedance analog and digital commons returns are essential for low noise performance. Coupling between analog inputs and digital lines should be minimized by careful layout. The comparator input (Pin 27) is extremely sensitive to noise. Any connection to this point should be as short as possible and shielded by Analog Common patterns.

POWER SUPPLY DECOUPLING

The power supplies should be bypassed with tantalum capacitors as shown in Figure 8 to obtain noise free operation. These capacitors should be located close to the ADC.

INPUT SCALING

The analog input should be scaled as close to the maximum input signal range as possible in order to utilize the maximum signal resolution of the A/D converter. Connect the input signal as shown in Table II. See Figure 9 for circuit details.

INPUT SIGNAL RANGE	OUTPUT CODE	CONNECT PIN 26 TO PIN	CONNECT PIN 24 TO	CONNECT INPUT SIGNAL TO PIN
±10V	COB or CTC ⁽¹⁾	27	Input Signal	24
±5V	COB or CTC ⁽¹⁾	27	Open	25
±2.5V	COB or CTC ⁽¹⁾	27	Pin 27	25
0 to +5V	CSB	22	Pin 27	25
0 to +10V	CSB	22	Open	25
0 to +20V	CSB	22	Input Signal	24

NOTE: (1) Obtained by inverting MSB pin 1.

TABLE II. ADC71 Input Scaling Connections.

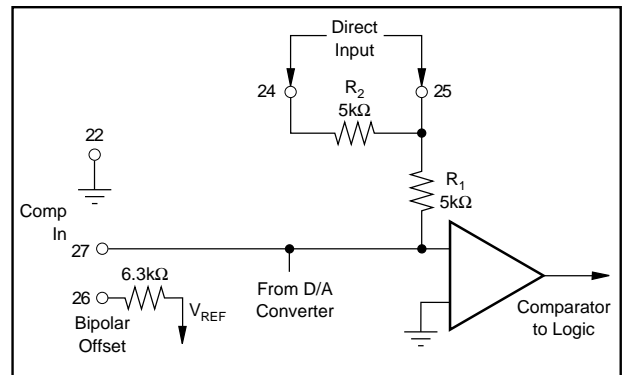

FIGURE 9. ADC71 Input Scaling Circuit.

OPTIONAL EXTERNAL GAIN AND OFFSET ADJUSTMENTS

Gain and Offset errors may be trimmed to zero using external gain and offset trim potentiometers connected to the ADC as shown in Figure 6 and 7. Multiturn potentiometers with 100ppm/°C or better TCRs are recommended for minimum drift over temperature and time. These pots may be any value from 10kΩ to 100kΩ. All resistors should be 20% carbon or better. Pin 29 (Gain Adjust) and Pin 27 (Offset Adjust) may be left open if no external adjustment is required.

ADJUSTMENT PROCEDURE

OFFSET — Connect the Offset potentiometer (make sure R_1 is as close to pin 27 as possible) as shown in Figure 6. Sweep the input through the end point transition voltage that should cause an output transition to all bits Off (E_{IN}).

Adjust the Offset potentiometer until the actual end point transition voltage occurs at E_{IN} . The ideal transition voltage values of the input are given in Table I.

GAIN — Connect the Gain Adjust potentiometer as shown in Figure 7. Sweep the input through the end point transition voltage that should cause an output transition to all bits on (E_{IN}). Adjust the Gain potentiometer until the actual end point transition voltage occurs at E_{IN} .

Table I details the transition voltage levels required.

CONVERT COMMAND CONSIDERATIONS

Convert command resets the converter whenever taken high. This insures a valid conversion on the first conversion after power-up.

Convert command must stay low during a conversion unless it is desired to reset the converter during a conversion.

ADDITIONAL CONNECTIONS REQUIRED

The ADC71 may be operated at faster speeds by connecting the Short-Cycle Input, pin 32, as shown in Table III. Conversion speeds, linearity, and resolutions are shown for reference.

OUTPUT DRIVE

Normally all ADC71 logic outputs will drive two standard TTL loads; however, if long digital lines must be driver, external logic buffers are recommended.

HEAT DISSIPATION

The ADC71 dissipates approximately 0.6W (typical) and the packages have a case-to-ambient thermal resistance (θ_{CA}) of 25°C/W. For operation above 85°C, θ_{CA} should be lowered by a heat sink or by forced air over the surface of the package. See Figure 10 for θ_{CA} requirement above 85°C. If the converter is mounted on a PC card, improved thermal contact with the copper ground plane under the case can be achieved using a silicone heat sink compound. On a 0.062" thick PC card with a 16 square in (min) area, this techniques will allow operation to 85°C.

RESOLUTION (Bits)	16	14	13	12
Connect Pin 32 to	Open	Pin 15	Pin 14	Pin 13
Maximum Conversion Speed (μ s) ⁽¹⁾	57	50	46.5	43
Maximum Nonlinearity at 25°C (% of FSR)	0.003 ⁽²⁾	0.003 ⁽²⁾	0.006	0.006

NOTES: (1) Max conversion time to maintain specified nonlinearity error.
(2) BH and KH models only.

TABLE III. Short-Cycle Connections and Specifications for 12- to 14-Bit Resolutions.

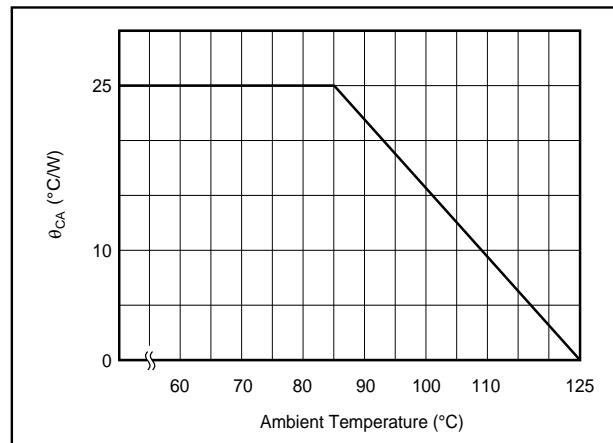

FIGURE 10. θ_{CA} Requirement Above 85°C.

This datasheet has been downloaded from:

www.DatasheetCatalog.com

Datasheets for electronic components.



LittleDiode supplies new, hard to find or obsolete electronic components and semiconductors all over the world.

With over two million different components listed you are sure to find the part you need.

Feel free to visit us today at our online store:

LittleDiode.com

Looking forward to providing you with the best possible service.