

## ADF4116/ADF4117/ADF4118

### FEATURES

- ADF4116: 550 MHz**
- ADF4117: 1.2 GHz**
- ADF4118: 3.0 GHz**
- 2.7 V to 5.5 V Power Supply**
- Separate  $V_p$  Allows Extended Tuning Voltage in 3 V Systems**
- Selected Charge Pump Currents**
- Dual Modulus Prescaler**
- ADF4116: 8/9**
- ADF4117/ADF4118: 32/33**
- 3-Wire Serial Interface**
- Digital Lock Detect**
- Power-Down Mode**
- Fast Lock Mode**

### APPLICATIONS

- Base Stations for Wireless Radio (GSM, PCS, DCS, CDMA, WCDMA)**
- Wireless Handsets (GSM, PCS, DCS, CDMA, WCDMA)**
- Wireless LANS**
- Communications Test Equipment**
- CATV Equipment**

### GENERAL DESCRIPTION

The ADF4116 family of frequency synthesizers can be used to implement local oscillators in the up-conversion and down-conversion sections of wireless receivers and transmitters. They consist of a low-noise digital PFD (Phase Frequency Detector), a precision charge pump, a programmable reference divider, programmable A and B counters and a dual-modulus prescaler (P/P+1). The A (5-bit) and B (13-bit) counters, in conjunction with the dual modulus prescaler (P/P+1), implement an N divider ( $N = BP + A$ ). In addition, the 14-bit reference counter (R Counter), allows selectable REF<sub>IN</sub> frequencies at the PFD input. A complete PLL (Phase-Locked Loop) can be implemented if the synthesizer is used with an external loop filter and VCO (Voltage Controlled Oscillator).

Control of all the on-chip registers is via a simple 3-wire interface. The devices operate with a power supply ranging from 2.7 V to 5.5 V and can be powered down when not in use.

### FUNCTIONAL BLOCK DIAGRAM

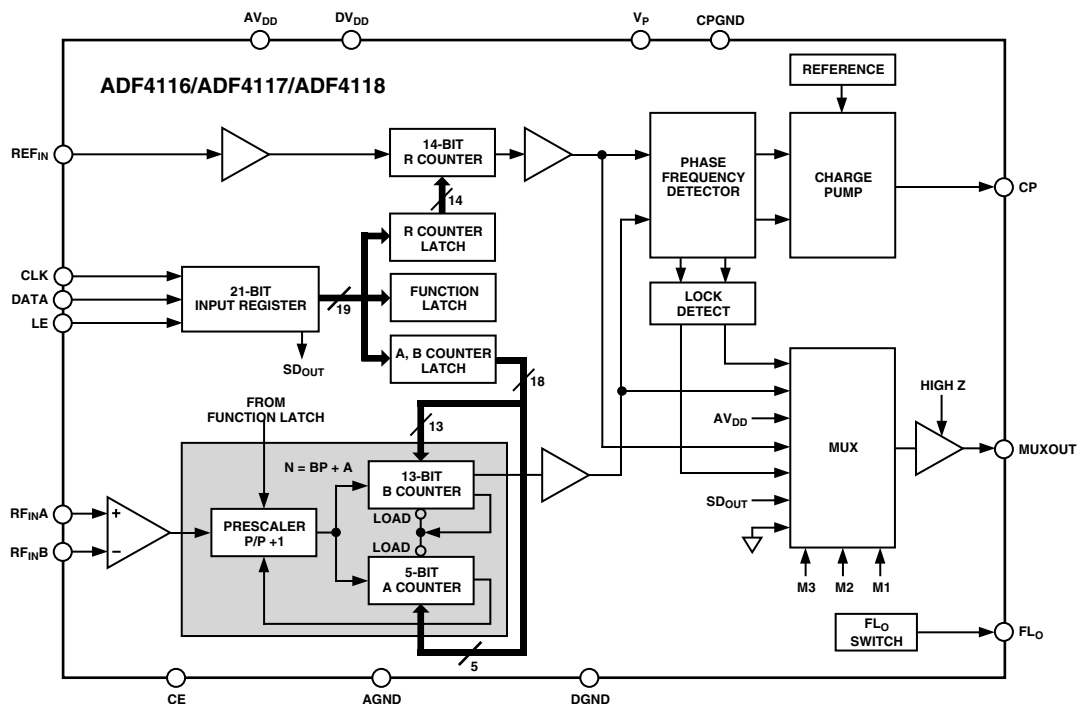

REV. 0

Information furnished by Analog Devices is believed to be accurate and reliable. However, no responsibility is assumed by Analog Devices for its use, nor for any infringements of patents or other rights of third parties which may result from its use. No license is granted by implication or otherwise under any patent or patent rights of Analog Devices.

# ADF4116/ADF4117/ADF4118—SPECIFICATIONS<sup>1</sup>

( $AV_{DD} = DV_{DD} = 3\text{ V} \pm 10\%$ ,  $5\text{ V} \pm 10\%$ ;  $AV_{DD} \leq V_P \leq 6.0\text{ V}$ ;  $AGND = DGND = CPGND = 0\text{ V}$ ;  $T_A = T_{MIN}$  to  $T_{MAX}$  unless otherwise noted)

Parameter	B Version	B Chips <sup>2</sup>	Unit	Test Conditions/Comments
<b>RF CHARACTERISTICS</b>				
RF Input Frequency				See Figure 22 for Input Circuit
ADF4116	45/550	45/550	MHz min/max	
ADF4117	0.045/1.2	0.045/1.2	GHz min/max	
ADF4118	0.1/3.0	0.1/3.0	GHz min/max	Input Level = -10 dBm
ADF4118	0.2/3.0	0.2/3.0	GHz min/max	
Maximum Allowable Prescaler Output Frequency <sup>3</sup>	165	165	MHz max	$AV_{DD}, DV_{DD} = 3\text{ V}$
	200	200	MHz max	$AV_{DD}, DV_{DD} = 5\text{ V}$
RF Input Sensitivity	-15/0	-15/0	dBm min/max	$AV_{DD} = 3\text{ V}$
	-10/0	-10/0	dBm min/max	$AV_{DD} = 5\text{ V}$
<b>REFIN CHARACTERISTICS</b>				
Reference Input Frequency	0/100	0/100	MHz min/max	
Reference Input Sensitivity <sup>4</sup>	-5/0	-5/0	dBm min/max	AC-Coupled. When DC-Coupled: 0 to $V_{DD}$ Max (CMOS Compatible)
REFIN Input Capacitance	10	10	pF max	
REFIN Input Current	$\pm 100$	$\pm 100$	$\mu\text{A}$ max	
<b>PHASE DETECTOR FREQUENCY<sup>5</sup></b>				
	55	55	MHz max	
<b>CHARGE PUMP</b>				
$I_{CP}$ Sink/Source				
High Value	1	1	mA typ	
Low Value	250	250	$\mu\text{A}$ typ	
Absolute Accuracy	2.5	2.5	% typ	
$I_{CP}$ Three-State Leakage Current	1	1	nA max	
Sink and Source Current Matching	3	3	% typ	$0.5\text{ V} \leq V_{CP} \leq V_P - 0.5$
$I_{CP}$ vs. $V_{CP}$	2	2	% typ	$0.5\text{ V} \leq V_{CP} \leq V_P - 0.5$
$I_{CP}$ vs. Temperature	2	2	% typ	$V_{CP} = V_P/2$
<b>LOGIC INPUTS</b>				
$V_{INH}$ , Input High Voltage	$0.8 \times DV_{DD}$	$0.8 \times DV_{DD}$	V min	
$V_{INL}$ , Input Low Voltage	$0.2 \times DV_{DD}$	$0.2 \times DV_{DD}$	V max	
$I_{INH}/I_{INL}$ , Input Current	$\pm 1$	$\pm 1$	$\mu\text{A}$ max	
$C_{IN}$ , Input Capacitance	10	10	pF max	
Reference Input Current	$\pm 100$	$\pm 100$	$\mu\text{A}$ max	
<b>LOGIC OUTPUTS</b>				
$V_{OH}$ , Output High Voltage	$DV_{DD} - 0.4$	$DV_{DD} - 0.4$	V min	$I_{OH} = 500\ \mu\text{A}$
$V_{OL}$ , Output Low Voltage	0.4	0.4	V max	$I_{OL} = 500\ \mu\text{A}$
<b>POWER SUPPLIES</b>				
$AV_{DD}$	2.7/5.5	2.7/5.5	V min/V max	
$DV_{DD}$	$AV_{DD}$	$AV_{DD}$		
$V_P$	$AV_{DD}/6.0$	$AV_{DD}/6.0$	V min/V max	$AV_{DD} \leq V_P \leq 6.0\text{ V}$
$I_{DD}$ <sup>6</sup> ( $AI_{DD} + DI_{DD}$ )				See Figure 20
ADF4116	5.5	4.5	mA max	4.5 mA Typical
ADF4117	5.5	4.5	mA max	4.5 mA Typical
ADF4118	7.5	6.5	mA max	6.5 mA Typical
$I_P$	0.4	0.4	mA max	$T_A = 25^\circ\text{C}$
Low-Power Sleep Mode	1	1	$\mu\text{A}$ typ	

# ADF4116/ADF4117/ADF4118

Parameter	B Version	B Chips <sup>2</sup>	Unit	Test Conditions/Comments
<b>NOISE CHARACTERISTICS</b>				
ADF4118 Phase Noise Floor <sup>7</sup>	-170	-170	dBc/Hz typ	@ 25 kHz PFD Frequency
	-162	-162	dBc/Hz typ	@ 200 kHz PFD Frequency
Phase Noise Performance <sup>8</sup>				
ADF4116 <sup>9</sup> 540 MHz Output	-89	-89	dBc/Hz typ	@ 1 kHz Offset and 200 kHz PFD Frequency
ADF4117 <sup>10</sup> 900 MHz Output	-87	-87	dBc/Hz typ	Note 15
ADF4118 <sup>10</sup> 900 MHz Output	-90	-90	dBc/Hz typ	Note 15
ADF4117 <sup>11</sup> 836 MHz Output	-78	-78	dBc/Hz typ	@ 300 Hz Offset and 30 kHz PFD Frequency
ADF4118 <sup>12</sup> 1750 MHz Output	-85	-85	dBc/Hz typ	@ 1 kHz Offset and 200 kHz PFD Frequency
ADF4118 <sup>13</sup> 1750 MHz Output	-65	-65	dBc/Hz typ	@ 200 Hz Offset and 10 kHz PFD Frequency
ADF4118 <sup>14</sup> 1960 MHz Output	-84	-84	dBc/Hz typ	@ 1 kHz Offset and 200 kHz PFD Frequency
<b>Spurious Signals</b>				
ADF4116 <sup>9</sup> 540 MHz Output	-88/-99	-88/-99	dBc typ	@ 200 kHz/400 kHz and 200 kHz PFD Frequency
ADF4117 <sup>10</sup> 900 MHz Output	-90/-104	-90/-104	dBc typ	Note 15
ADF4118 <sup>10</sup> 900 MHz Output	-91/-100	-91/-100	dBc typ	Note 15
ADF4117 <sup>11</sup> 836 MHz Output	-80/-84	-80/-84	dBc typ	@ 30 kHz/60 kHz and 30 kHz PFD Frequency
ADF4118 <sup>12</sup> 1750 MHz Output	-88/-90	-88/-90	dBc typ	@ 200 kHz/400 kHz and 200 kHz PFD Frequency
ADF4118 <sup>13</sup> 1750 MHz Output	-65/-73	-65/-73	dBc typ	@ 10 kHz/20 kHz and 10 kHz PFD Frequency
ADF4118 <sup>14</sup> 1960 MHz Output	-80/-86	-80/-86	dBc typ	@ 200 kHz/400 kHz and 200 kHz PFD Frequency

## NOTES

<sup>1</sup>Operating temperature range is as follows: B Version: -40°C to +85°C.

<sup>2</sup>The B Chip specifications are given as typical values.

<sup>3</sup>This is the maximum operating frequency of the CMOS counters.

<sup>4</sup>AV<sub>DD</sub> = DV<sub>DD</sub> = 3 V; for AV<sub>DD</sub> = DV<sub>DD</sub> = 5 V, use CMOS-compatible levels.

<sup>5</sup>Guaranteed by design. Sample tested to ensure compliance.

<sup>6</sup>AV<sub>DD</sub> = DV<sub>DD</sub> = 3 V; RF<sub>IN</sub> for ADF4116 = 540 MHz; RF<sub>IN</sub> for ADF4117, ADF4118 = 900 MHz.

<sup>7</sup>The synthesizer phase noise floor is estimated by measuring the in-band phase noise at the output of the VCO and subtracting 20 log N (where N is the N divider value).

<sup>8</sup>The phase noise is measured with the EVAL-ADF411xEB Evaluation Board and the HP8562E Spectrum Analyzer. The spectrum analyzer provides the REFIN for the synthesizer (f<sub>REFOUT</sub> = 10 MHz @ 0 dBm).

<sup>9</sup>f<sub>REFIN</sub> = 10 MHz; f<sub>PFD</sub> = 200 kHz; Offset frequency = 1 kHz; f<sub>RF</sub> = 540 MHz; N = 2700; Loop B/W = 20 kHz.

<sup>10</sup>f<sub>REFIN</sub> = 10 MHz; f<sub>PFD</sub> = 200 kHz; Offset frequency = 1 kHz; f<sub>RF</sub> = 900 MHz; N = 4500; Loop B/W = 20 kHz.

<sup>11</sup>f<sub>REFIN</sub> = 10 MHz; f<sub>PFD</sub> = 30 kHz; Offset frequency = 300 Hz; f<sub>RF</sub> = 836 MHz; N = 27867; Loop B/W = 3 kHz.

<sup>12</sup>f<sub>REFIN</sub> = 10 MHz; f<sub>PFD</sub> = 200 kHz; Offset frequency = 1 kHz; f<sub>RF</sub> = 1750 MHz; N = 8750; Loop B/W = 20 kHz.

<sup>13</sup>f<sub>REFIN</sub> = 10 MHz; f<sub>PFD</sub> = 10 kHz; Offset frequency = 200 Hz; f<sub>RF</sub> = 1750 MHz; N = 175000; Loop B/W = 1 kHz.

<sup>14</sup>f<sub>REFIN</sub> = 10 MHz; f<sub>PFD</sub> = 200 kHz; Offset frequency = 1 kHz; f<sub>RF</sub> = 1960 MHz; N = 9800; Loop B/W = 20 kHz.

<sup>15</sup>Same conditions as above.

Specifications subject to change without notice.

## TIMING CHARACTERISTICS<sup>1</sup> (AV<sub>DD</sub> = DV<sub>DD</sub> = 3 V ± 10%, 5 V ± 10%; AV<sub>DD</sub> ≤ V<sub>P</sub> < 6.0 V; AGND = DGND = CPGND = 0 V; T<sub>A</sub> = T<sub>MIN</sub> to T<sub>MAX</sub> unless otherwise noted)

Parameter	Limit at T <sub>MIN</sub> to T <sub>MAX</sub> (B Version)	Unit	Test Conditions/Comments
t <sub>1</sub>	10	ns min	DATA to CLOCK Setup Time
t <sub>2</sub>	10	ns min	DATA to CLOCK Hold Time
t <sub>3</sub>	25	ns min	CLOCK High Duration
t <sub>4</sub>	25	ns min	CLOCK Low Duration
t <sub>5</sub>	10	ns min	CLOCK to LE Setup Time
t <sub>6</sub>	20	ns min	LE Pulswidth

## NOTE

<sup>1</sup>Guaranteed by design but not production tested.

Specifications subject to change without notice.

# ADF4116/ADF4117/ADF4118

## ABSOLUTE MAXIMUM RATINGS<sup>1,2</sup>

(T<sub>A</sub> = 25°C unless otherwise noted)

AV <sub>DD</sub> to GND <sup>3</sup>	-0.3 V to +7 V
AV <sub>DD</sub> to DV <sub>DD</sub>	-0.3 V to +0.3 V
V <sub>P</sub> to GND	-0.3 V to +7 V
V <sub>P</sub> to AV <sub>DD</sub>	-0.3 V to +5.5 V
Digital I/O Voltage to GND	-0.3 V to V <sub>DD</sub> + 0.3 V
Analog I/O Voltage to GND	-0.3 V to V <sub>P</sub> + 0.3 V
Operating Temperature Range	
Industrial (B Version)	-40°C to +85°C
Storage Temperature Range	-65°C to +150°C
Maximum Junction Temperature	150°C
TSSOP θ <sub>JA</sub> Thermal Impedance	150.4°C/W
CSP θ <sub>JA</sub> Thermal Impedance	
(Paddle Soldered)	122°C/W
(Paddle Not Soldered)	216°C/W

## Lead Temperature, Soldering

Vapor Phase (60 sec)	215°C
Infrared (15 sec)	220°C

## NOTES

<sup>1</sup> Stresses above those listed under Absolute Maximum Ratings may cause permanent damage to the device. This is a stress rating only; functional operation of the device at these or any other conditions above those listed in the operational sections of this specification is not implied. Exposure to absolute maximum rating conditions for extended periods may affect device reliability.

<sup>2</sup> This device is a high-performance RF integrated circuit with an ESD rating of < 2 kV and it is ESD sensitive. Proper precautions should be taken for handling and assembly.

<sup>3</sup> GND = AGND = DGND = 0 V.

## TRANSISTOR COUNT

6425 (CMOS) and 303 (Bipolar).

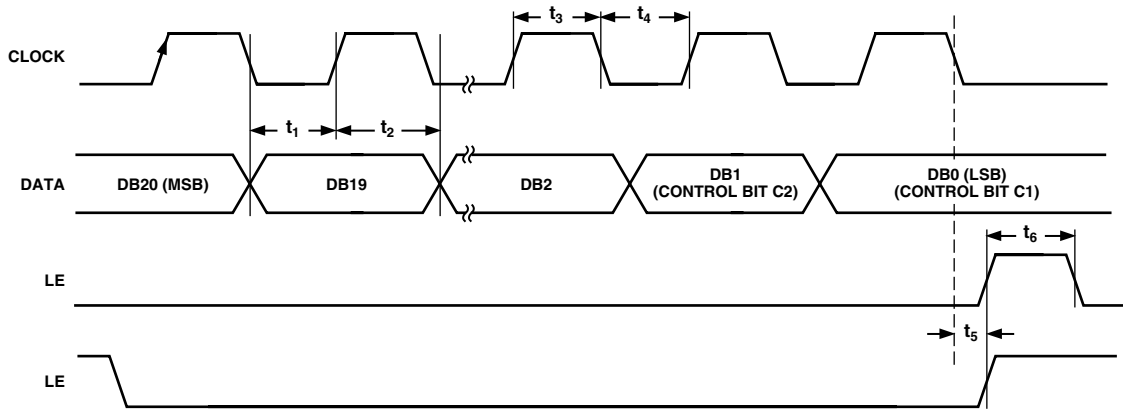

Figure 1. Timing Diagram

## CAUTION

ESD (electrostatic discharge) sensitive device. Electrostatic charges as high as 4000 V readily accumulate on the human body and test equipment and can discharge without detection. Although the ADF4116/ADF4117/ADF4118 features proprietary ESD protection circuitry, permanent damage may occur on devices subjected to high-energy electrostatic discharges. Therefore, proper ESD precautions are recommended to avoid performance degradation or loss of functionality.



## ORDERING GUIDE

Model	Temperature Range	Package Description	Package Option*
ADF4116BRU	-40°C to +85°C	Thin Shrink Small Outline Package (TSSOP)	RU-16
ADF4116BCP	-40°C to +85°C	Chip Scale Package	CP-20
ADF4117BRU	-40°C to +85°C	Thin Shrink Small Outline Package (TSSOP)	RU-16
ADF4117BCP	-40°C to +85°C	Chip Scale Package	CP-20
ADF4118BRU	-40°C to +85°C	Thin Shrink Small Outline Package (TSSOP)	RU-16
ADF4118BCP	-40°C to +85°C	Chip Scale Package	CP-20

\*Contact the factory for chip availability.

## PIN FUNCTION DESCRIPTIONS

Pin No.	Mnemonic	Function
1	FL <sub>O</sub>	Fast Lock Switch Output. This can be used to switch an external resistor to change the loop filter bandwidth. This will speed up locking of the PLL.
2	CP	Charge Pump Output. When enabled, this provides the $\pm I_{CP}$ to the external loop filter, which in turn drives the external VCO.
3	CPGND	Charge Pump Ground. This is the ground return path for the charge pump.
4	AGND	Analog Ground. This is the ground return path for the prescaler.
5	RF <sub>INB</sub>	Complementary Input to the RF Prescaler. This point should be decoupled to the ground plane with a small bypass capacitor, typically 100 pF. See Figure 22.
6	RF <sub>INA</sub>	Input to the RF Prescaler. This small signal input is normally ac-coupled from the VCO.
7	AV <sub>DD</sub>	Analog Power Supply. This may range from 2.7 V to 5.5 V. Decoupling capacitors to the analog ground plane should be placed as close as possible to this pin. AV <sub>DD</sub> must be the same value as DV <sub>DD</sub> .
8	REF <sub>IN</sub>	Reference Input. This is a CMOS input with a nominal threshold of $V_{DD}/2$ and an equivalent input resistance of 100 k $\Omega$ . See Figure 21. The oscillator input can be driven from a TTL or CMOS crystal oscillator or it can be ac-coupled.
9	DGND	Digital Ground.
10	CE	Chip Enable. A logic low on this pin powers down the device and puts the charge pump output into three-state mode. Taking the pin high will power up the device depending on the status of the power-down bit F2.
11	CLK	Serial Clock Input. This serial clock is used to clock in the serial data to the registers. The data is latched into the 21-bit shift register on the CLK rising edge. This input is a high impedance CMOS input.
12	DATA	Serial Data Input. The serial data is loaded MSB first with the two LSBs being the control bits. This input is a high impedance CMOS input.
13	LE	Load Enable, CMOS Input. When LE goes high, the data stored in the shift registers is loaded into one of the four latches, the latch being selected using the control bits.
14	MUXOUT	This multiplexer output allows either the Lock Detect, the scaled RF or the scaled Reference Frequency to be accessed externally.
15	DV <sub>DD</sub>	Digital Power Supply. This may range from 2.7 V to 5.5 V. Decoupling capacitors to the digital ground plane should be placed as close as possible to this pin. DV <sub>DD</sub> must be the same value as AV <sub>DD</sub> .
16	V <sub>P</sub>	Charge Pump Power Supply. This should be greater than or equal to V <sub>DD</sub> . In systems where V <sub>DD</sub> is 3 V, it can be set to 5 V and used to drive a VCO with a tuning range of up to 6 V.

## PIN CONFIGURATIONS

**TSSOP**

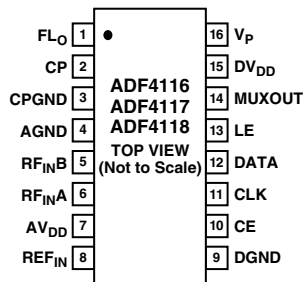

**Chip Scale Package**

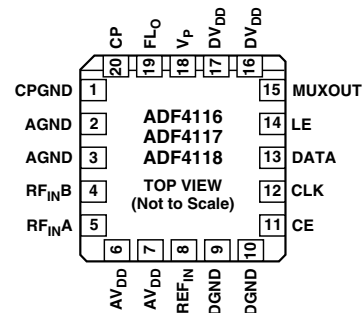

# ADF4116/ADF4117/ADF4118—Typical Performance Characteristics

Table I. S-Parameter Data for the ADF4118 RF Input (Up to 1.8 GHz)

FREQ-UNIT GHZ	PARAM-TYPE S		DATA-FORMAT MA	KEYWORD IMPEDANCE- OHMS R 50	
FREQ	MagS11	AngS11	FREQ	MagS11	AngS11
0.05	0.89207	-2.0571	0.95	0.92087	-36.961
0.10	0.8886	-4.4427	1.00	0.93788	-39.343
0.15	0.89022	-6.3212	1.05	0.9512	-40.134
0.20	0.96323	-2.1393	1.10	0.93458	-43.747
0.25	0.90566	-12.13	1.15	0.94782	-44.393
0.30	0.90307	-13.52	1.20	0.96875	-46.937
0.35	0.89318	-15.746	1.25	0.92216	-49.6
0.40	0.89806	-18.056	1.30	0.93755	-51.884
0.45	0.89565	-19.693	1.35	0.96178	-51.21
0.50	0.88538	-22.246	1.40	0.94354	-53.55
0.55	0.89699	-24.336	1.45	0.95189	-56.786
0.60	0.89927	-25.948	1.50	0.97647	-58.781
0.65	0.87797	-28.457	1.55	0.98619	-60.545
0.70	0.90765	-29.735	1.60	0.95459	-61.43
0.75	0.88526	-31.879	1.65	0.97945	-61.241
0.80	0.81267	-32.681	1.70	0.98864	-64.051
0.85	0.90357	-31.522	1.75	0.97399	-66.19
0.90	0.92954	-34.222	1.80	0.97216	-63.775

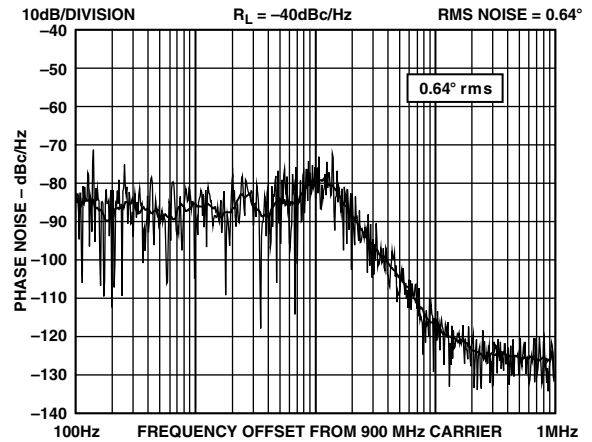

Figure 4. ADF4118 Integrated Phase Noise (900 MHz, 200 kHz, 35 kHz, Typical Lock Time: 200  $\mu$ s)

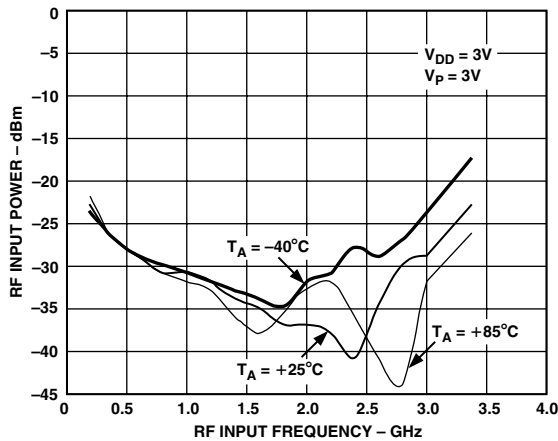

Figure 2. Input Sensitivity (ADF4118)

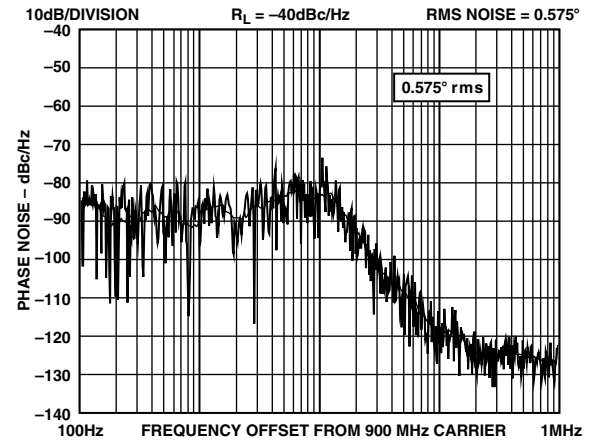

Figure 5. ADF4118 Integrated Phase Noise (900 MHz, 200 kHz, 20 kHz, Typical Lock Time: 400  $\mu$ s)

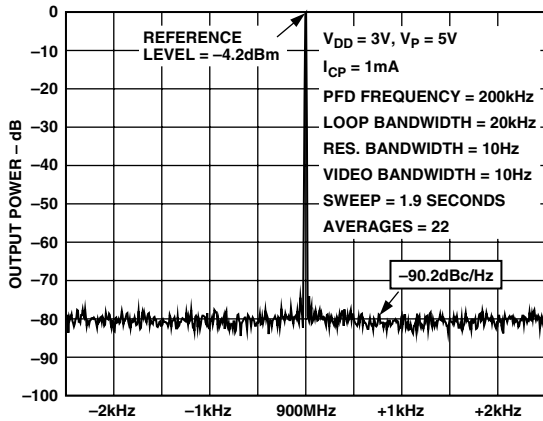

Figure 3. ADF4118 Phase Noise (900 MHz, 200 kHz, 20 kHz)

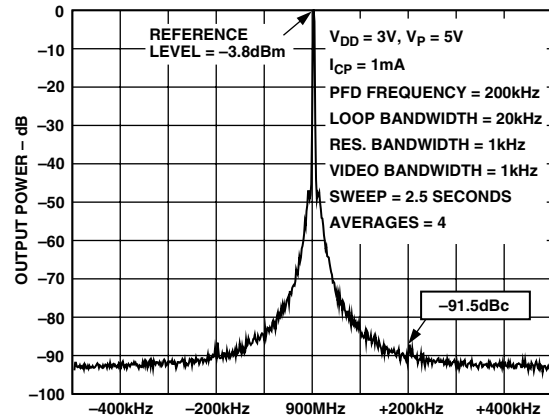

Figure 6. ADF4118 Reference Spurs (900 MHz, 200 kHz, 20 kHz)

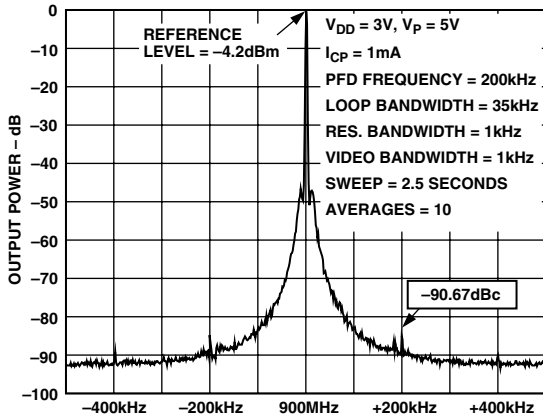

Figure 7. ADF4118 Reference Spurs (900 MHz, 200 kHz, 35 kHz)

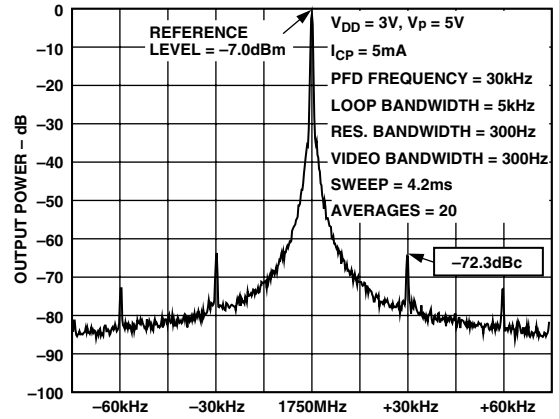

Figure 10. ADF4118 Reference Spurs (1750 MHz, 30 kHz, 3 kHz)

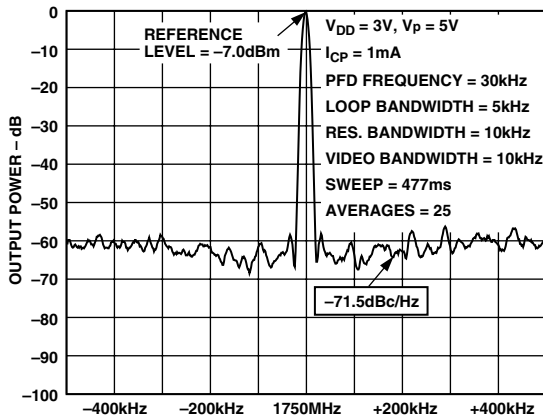

Figure 8. ADF4118 Phase Noise (1750 MHz, 30 kHz, 3 kHz)

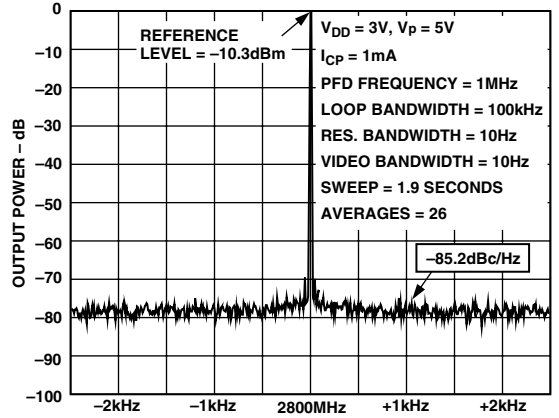

Figure 11. ADF4118 Phase Noise (2800 MHz, 1 MHz, 100 kHz)

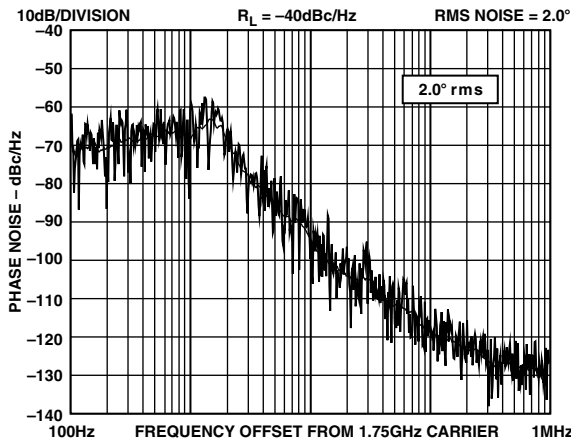

Figure 9. ADF4118 Integrated Phase Noise (1750 MHz, 30 kHz, 3 kHz)

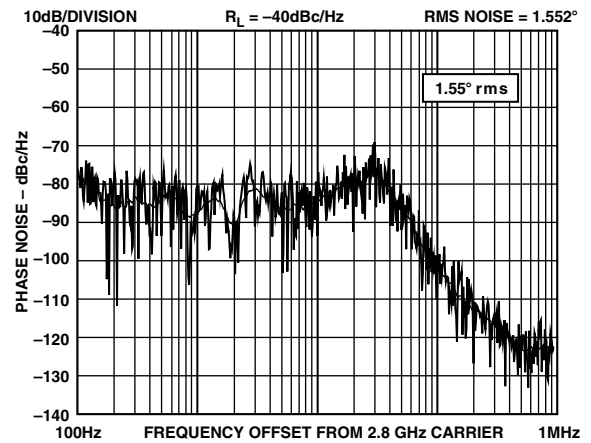

Figure 12. ADF4118 Integrated Phase Noise (2800 MHz, 1 MHz, 100 kHz)

# ADF4116/ADF4117/ADF4118

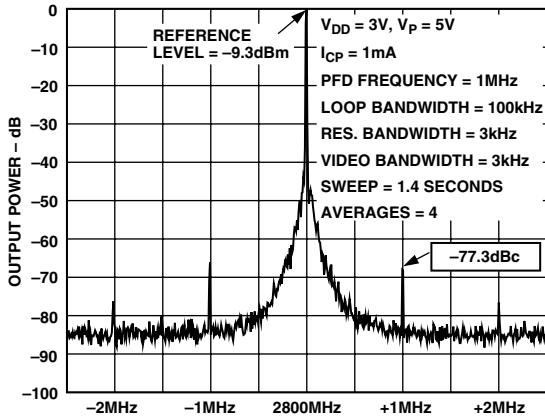

Figure 13. ADF4118 Reference Spurs (2800 MHz, 1 MHz, 100 kHz)

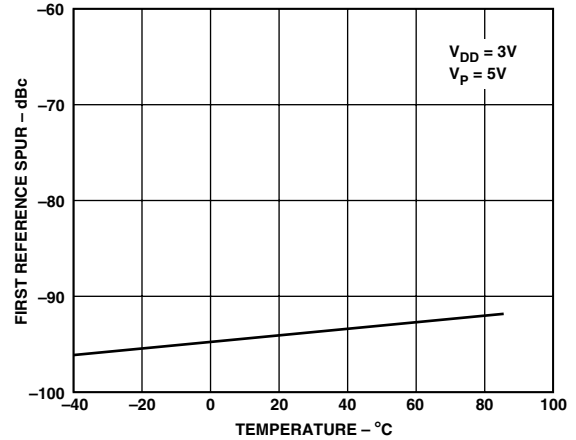

Figure 16. ADF4118 Reference Spurs vs. Temperature (900 MHz, 200 kHz, 20 kHz)

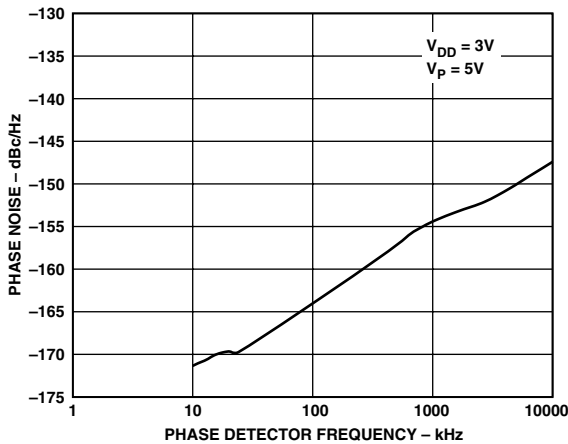

Figure 14. ADF4118 Phase Noise (Referred to CP Output) vs. PFD Frequency

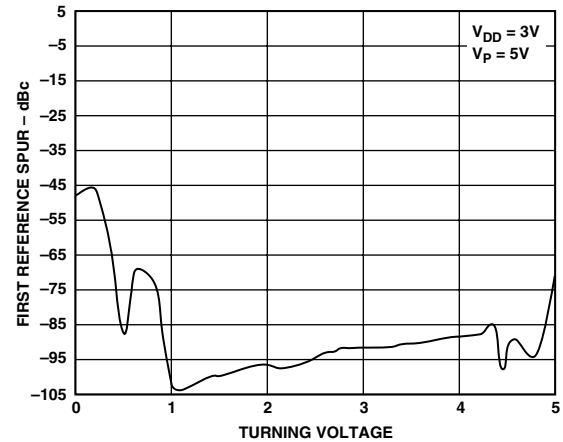

Figure 17. ADF4118 Reference Spurs (200 kHz) vs.  $V_{TUNE}$  (900 MHz, 200 kHz, 20 kHz)

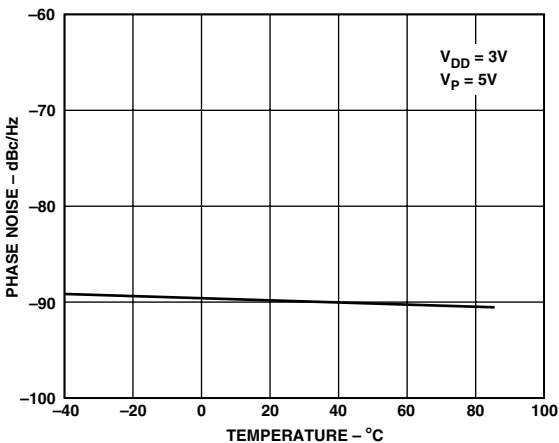

Figure 15. ADF4118 Phase Noise vs. Temperature (900 MHz, 200 kHz, 20 kHz)

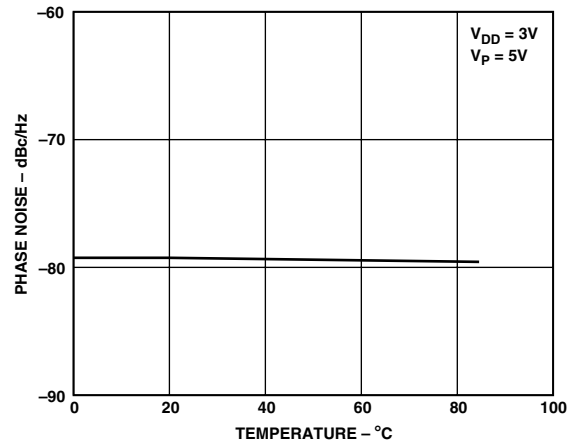

Figure 18. ADF4118 Phase Noise vs. Temperature (836 MHz, 30 kHz, 3 kHz)

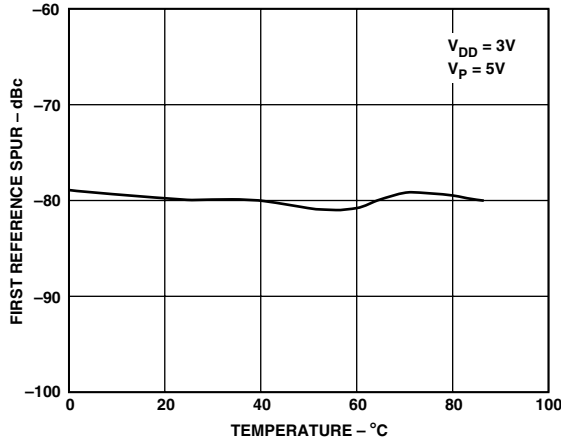

Figure 19. ADF4118 Reference Spurs vs. Temperature (836 MHz, 30 kHz, 3 kHz)

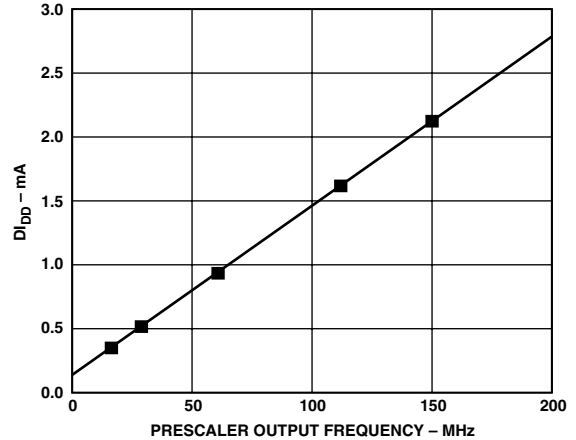

Figure 20.  $D_{I_{DD}}$  vs. Prescaler Output Frequency (ADF4116, ADF4117, ADF4118)

## CIRCUIT DESCRIPTION

### REFERENCE INPUT SECTION

The reference input stage is shown below in Figure 21. SW1 and SW2 are normally-closed switches. SW3 is normally-open. When power-down is initiated, SW3 is closed and SW1 and SW2 are opened. This ensures that there is no loading of the  $REF_{IN}$  pin on power-down.

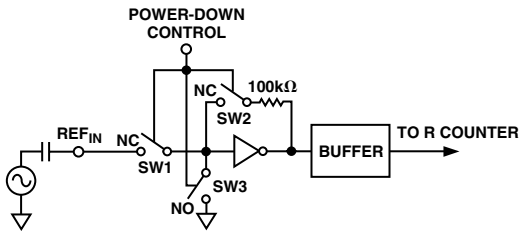

Figure 21. Reference Input Stage

### RF INPUT STAGE

The RF input stage is shown in Figure 22. It is followed by a 2-stage limiting amplifier to generate the CML clock levels needed for the prescaler.

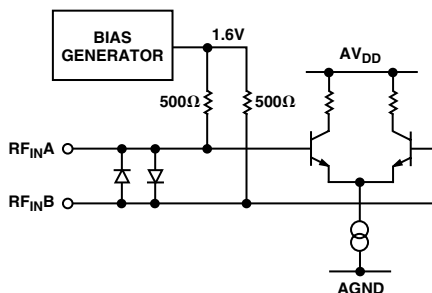

Figure 22. RF Input Stage

### PRESCALER (P/P + 1)

The dual modulus prescale ( $P/P + 1$ ), along with the A and B counters, enables the large division ratio,  $N$ , to be realized, ( $N = PB + A$ ). The dual-modulus prescaler takes the CML clock from the RF input stage and divides it down to a manageable frequency for the CMOS A and B counters. The prescaler is programmable. It can be set in software to 8/9 for the ADF4116, and set to 32/33 for the ADF4117 and ADF4118. It is based on a synchronous 4/5 core.

### A AND B COUNTERS

The A and B CMOS counters combine with the dual modulus prescaler to allow a wide ranging division ratio in the PLL feedback counter. The counters are specified to work when the prescaler output is 200 MHz or less.

### Pulse Swallow Function

The A and B counters, in conjunction with the dual modulus prescaler make it possible to generate output frequencies which are spaced only by the Reference Frequency divided by R. The equation for the VCO frequency is as follows:

$$f_{VCO} = [(P \times B) + A] \times f_{REFIN} / R$$

$f_{VCO}$  Output Frequency of external voltage controlled oscillator (VCO).

$P$  Preset modulus of dual modulus prescaler.

$B$  Preset Divide Ratio of binary 13-bit counter (3 to 8191).

$A$  Preset Divide Ratio of binary 5-bit swallow counter (0 to 31).

$f_{REFIN}$  Output frequency of the external reference frequency oscillator.

$R$  Preset divide ratio of binary 14-bit programmable reference counter (1 to 16383).

### R COUNTER

The 14-bit R counter allows the input reference frequency to be divided down to produce the input clock to the phase frequency detector (PFD). Division ratios from 1 to 16,383 are allowed.

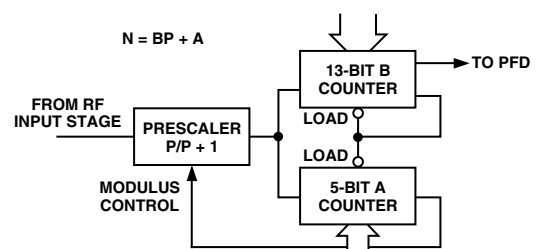

Figure 23. A and B Counters

# ADF4116/ADF4117/ADF4118

## PHASE FREQUENCY DETECTOR (PFD) AND CHARGE PUMP

The PFD takes inputs from the R counter and N counter and produces an output proportional to the phase and frequency difference between them. Figure 24 is a simplified schematic. The PFD includes a fixed delay element which sets the width of the antibacklash pulse. This is typically 3 ns. This pulse ensures that there is no dead zone in the PFD transfer function and gives a consistent reference spur level.

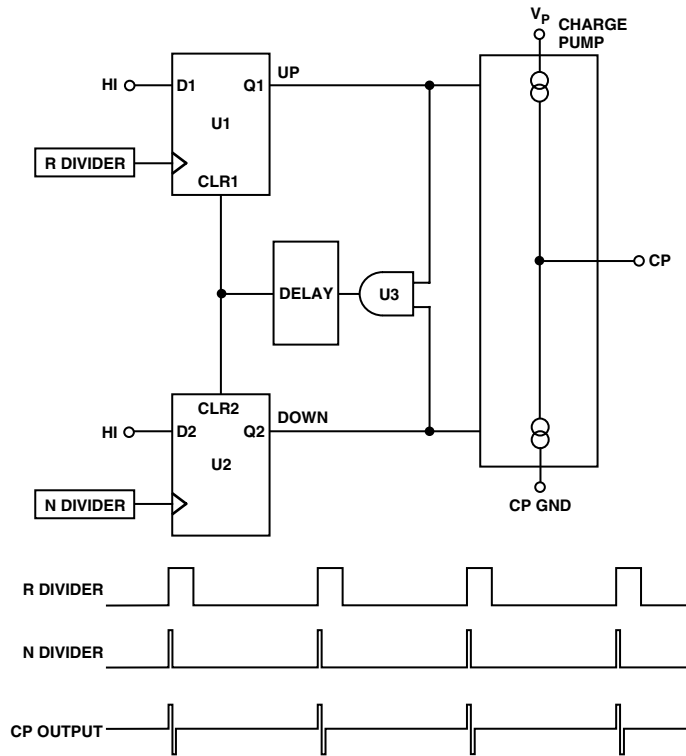

Figure 24. PFD Simplified Schematic and Timing (In Lock)

## MUXOUT AND LOCK DETECT

The output multiplexer on the ADF4116 family allows the user to access various internal points on the chip. The state of MUXOUT is controlled by M3, M2 and M1 in the function latch. Table VI shows the full truth table. Figure 25 shows the MUXOUT section in block diagram form.

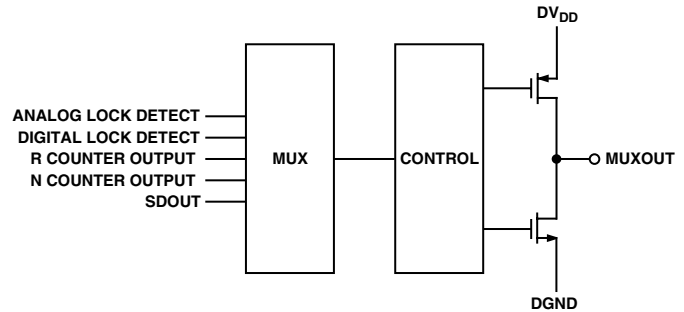

Figure 25. MUXOUT Circuit

## Lock Detect

MUXOUT can be programmed for two types of lock detect: Digital Lock Detect and Analog Lock Detect.

Digital Lock Detect is active high. It is set high when the phase error on three consecutive phase detector cycles is less than 15 ns. It will stay set high until a phase error of greater than 25 ns is detected on any subsequent PD cycle.

The N-channel open-drain analog lock detect should be operated with an external pull-up resistor of 10 kΩ nominal. When lock has been detected it is high with narrow low-going pulses.

## INPUT SHIFT REGISTER

The ADF4116 family digital section includes a 21-bit input shift register, a 14-bit R counter and a 13-bit N counter, comprising a 5-bit A counter and a 13-bit B counter. Data is clocked into the 21-bit shift register on each rising edge of CLK. The data is clocked in MSB first. Data is transferred from the shift register to one of four latches on the rising edge of LE. The destination latch is determined by the state of the two control bits (C2, C1) in the shift register. These are the two LSBs DB1, DB0 as shown in the timing diagram of Figure 1. The truth table for these bits is shown in Table VII. Table II shows a summary of how the latches are programmed.

Table II. C2, C1 Truth Table

Control Bits		Data Latch
C2	C1	
0	0	R Counter
0	1	N Counter (A and B)
1	0	Function Latch
1	1	Initialization Latch

Table III. ADF4116 Family Latch Summary

### REFERENCE COUNTER LATCH

LOCK DETECT PRECISION	TEST MODE BITS				14-BIT REFERENCE COUNTER, R														CONTROL BITS	
DB20	DB19	DB18	DB17	DB16	DB15	DB14	DB13	DB12	DB11	DB10	DB9	DB8	DB7	DB6	DB5	DB4	DB3	DB2	DB1	DB0
LDP	T4	T3	T2	T1	R14	R13	R12	R11	R10	R9	R8	R7	R6	R5	R4	R3	R2	R1	C2 (0)	C1 (0)

### AB COUNTER LATCH

CP GAIN	13-BIT B COUNTER													5-BIT A COUNTER					CONTROL BITS	
DB20	DB19	DB18	DB17	DB16	DB15	DB14	DB13	DB12	DB11	DB10	DB9	DB8	DB7	DB6	DB5	DB4	DB3	DB2	DB1	DB0
G1	B13	B12	B11	B10	B9	B8	B7	B6	B5	B4	B3	B2	B1	A5	A4	A3	A2	A1	C2 (0)	C1 (1)

### FUNCTION LATCH

RESERVED	POWER- DOWN 2	RESERVED			TIMER COUNTER CONTROL				FASTLOCK MODE	RESERVED	FASTLOCK ENABLE	CP THREE- STATE	PD POLARITY	MUXOUT CONTROL			POWER- DOWN 1	COUNT RESETTER	CONTROL BITS	
DB20	DB19	DB18	DB17	DB16	DB15	DB14	DB13	DB12	DB11	DB10	DB9	DB8	DB7	DB6	DB5	DB4	DB3	DB2	DB1	DB0
X	PD2	X	X	X	TC4	TC3	TC2	TC1	F6	X	F4	F3	F2	M3	M2	M1	PD1	F1	C2 (1)	C1 (0)

### INITIALIZATION LATCH

RESERVED	POWER- DOWN 2	RESERVED			TIMER COUNTER CONTROL				FASTLOCK MODE	RESERVED	FASTLOCK ENABLE	CP THREE- STATE	PD POLARITY	MUXOUT CONTROL			POWER- DOWN 1	COUNT RESETTER	CONTROL BITS	
DB20	DB19	DB18	DB17	DB16	DB15	DB14	DB13	DB12	DB11	DB10	DB9	DB8	DB7	DB6	DB5	DB4	DB3	DB2	DB1	DB0
X	PD2	X	X	X	TC4	TC3	TC2	TC1	F6	X	F4	F3	F2	M3	M2	M1	PD1	F1	C2 (1)	C1 (1)

# ADF4116/ADF4117/ADF4118

Table IV. Reference Counter Latch Map

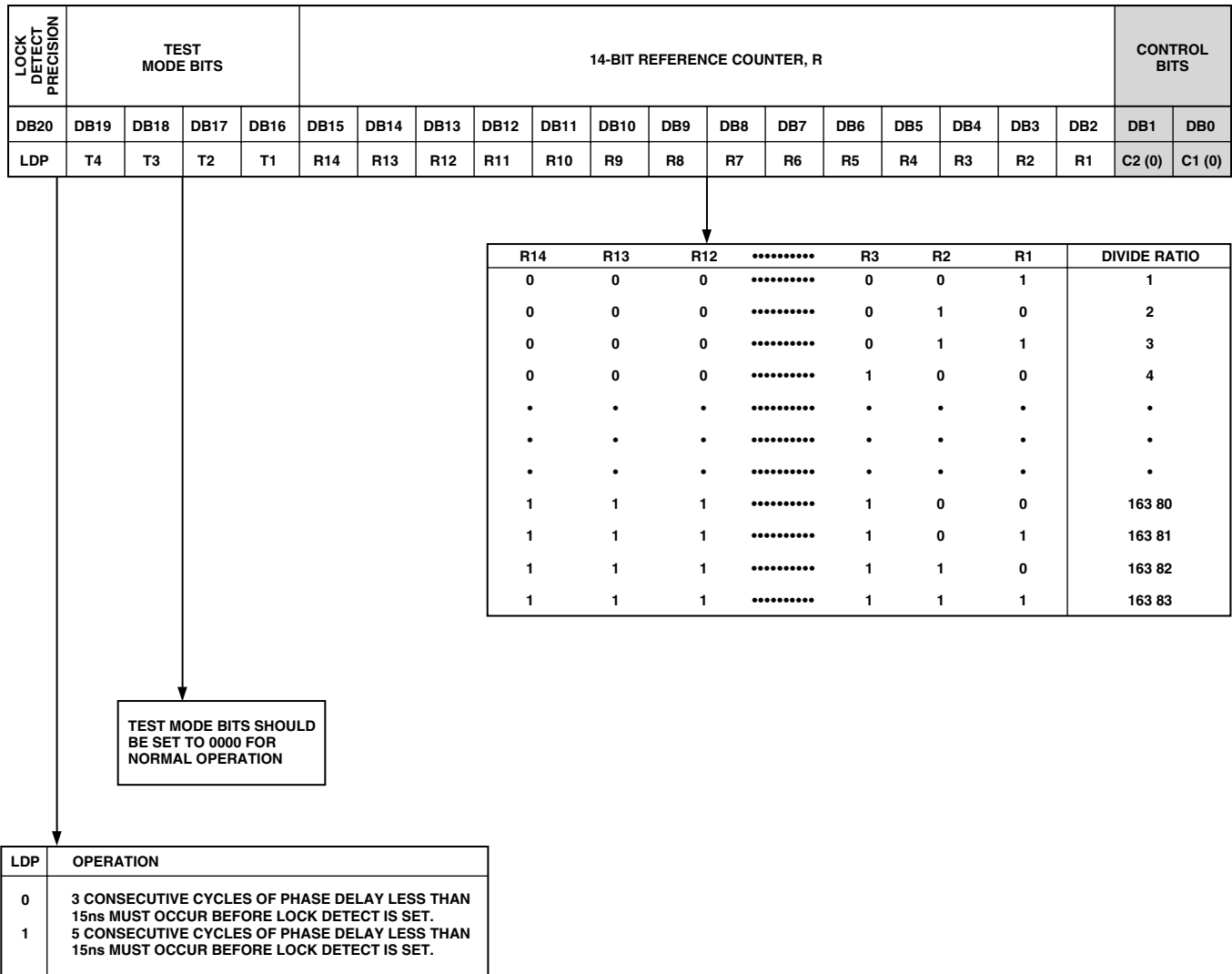

# ADF4116/ADF4117/ADF4118

Table V. AB Counter Latch Map

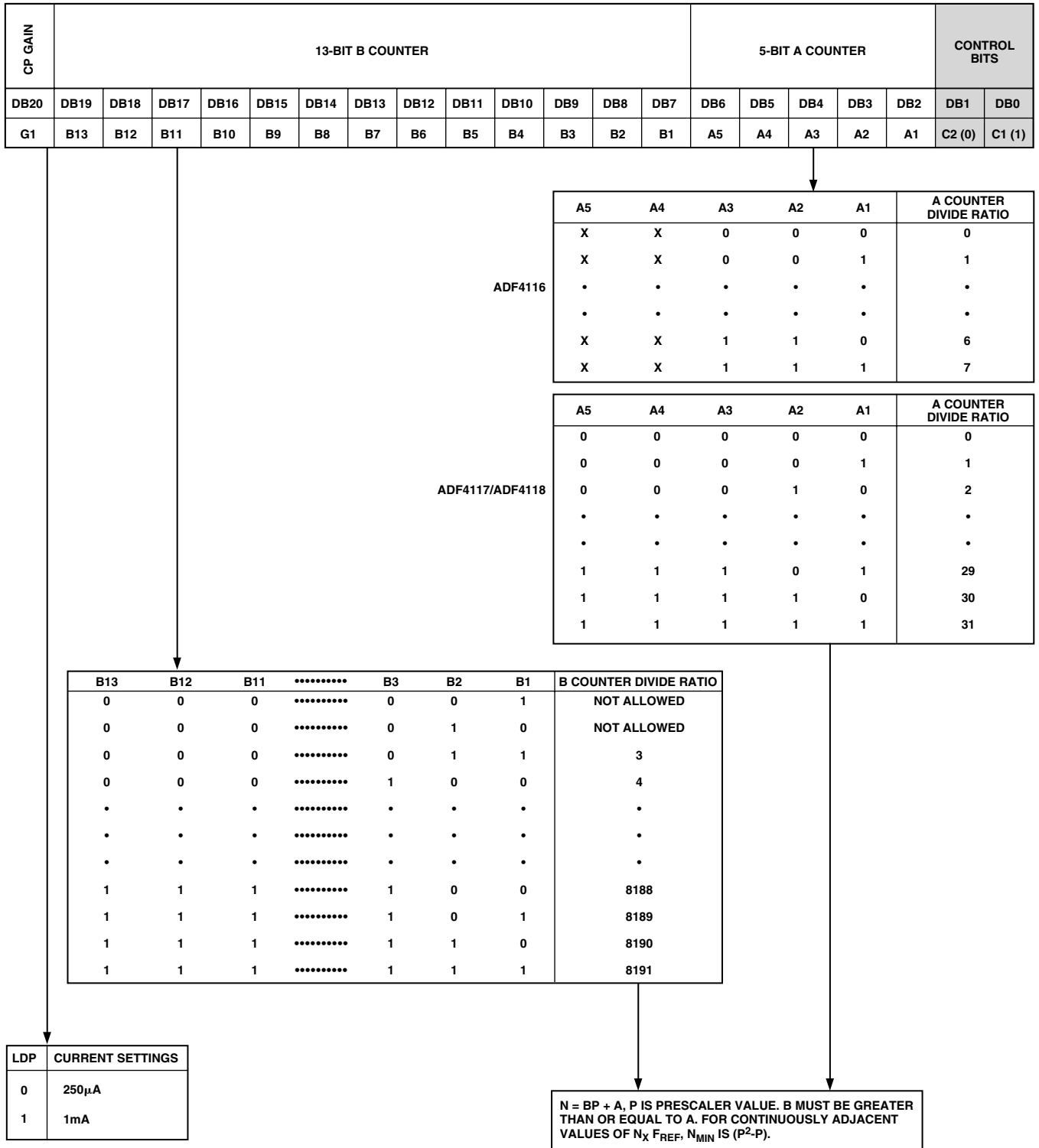
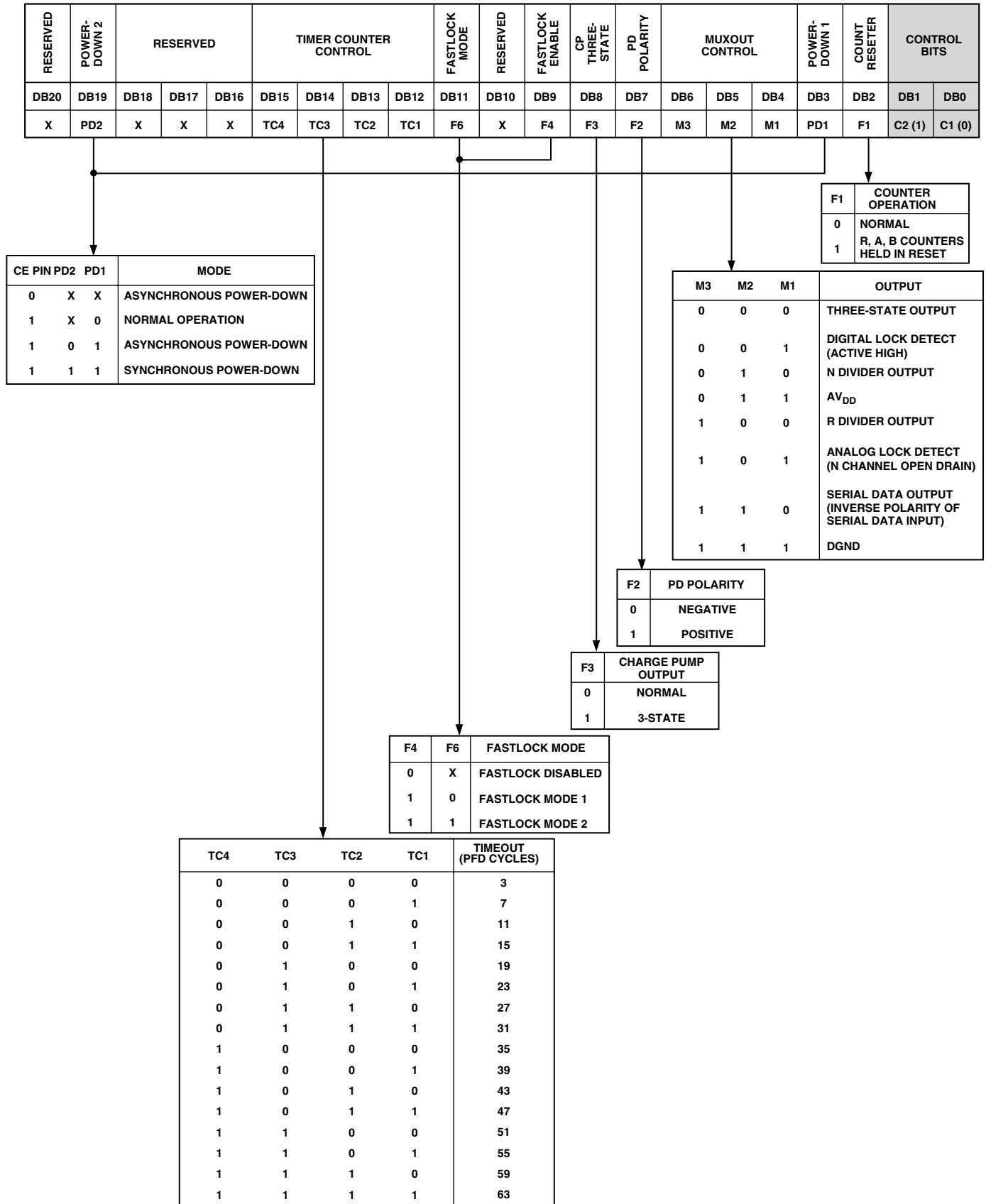
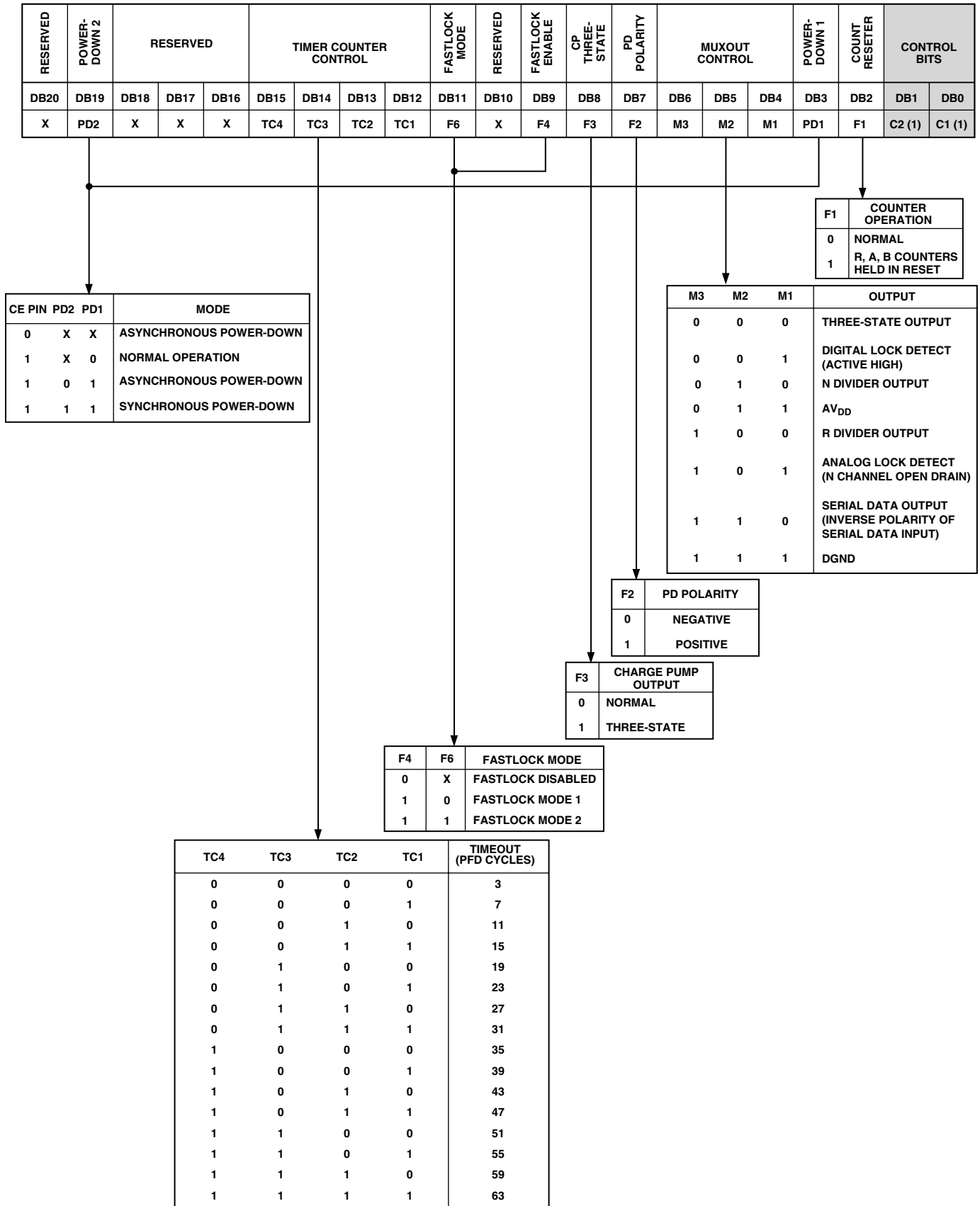

Table VI. Function Latch Map



**Table VII. Initialization Latch Map**



# ADF4116/ADF4117/ADF4118

## THE FUNCTION LATCH

With C2, C1 set to 1, 0, the on-chip function latch will be programmed. Table VI shows the input data format for programming the Function Latch.

### Counter Reset

DB2 (F1) is the counter reset bit. When this is “1,” the R counter and the A, B counters are reset. For normal operation this bit should be “0.” *Upon powering up, the F1 bit needs to be disabled, the N counter resumes counting in “close” alignment with the R counter. (The maximum error is one prescaler cycle.)*

### Power-Down

DB3 (PD1) and DB19 (PD2) on the ADF4116 family, provide programmable power-down modes. They are enabled by the CE pin.

When the CE pin is low, the device is immediately disabled regardless of the states of PD2, PD1.

In the programmed asynchronous power-down, the device powers down immediately after latching a “1” into bit PD1, with the condition that PD2 has been loaded with a “0.”

In the programmed synchronous power-down, the device power down is gated by the charge pump to prevent unwanted frequency jumps. Once the power-down is enabled by writing a “1” into bit PD1 (on condition that a “1” has also been loaded to PD2), then the device will go into power-down after the first successive charge pump event.

When a power down is activated (either synchronous or asynchronous mode including CE-pin-activated power down), the following events occur:

All active dc current paths are removed.

The R, N and timeout counters are forced to their load state conditions.

The charge pump is forced into three-state mode.

The digital clock detect circuitry is reset.

The RF<sub>IN</sub> input is debiased.

The oscillator input buffer circuitry is disabled.

The input register remains active and capable of loading and latching data.

### MUXOUT Control

The on-chip multiplexer is controlled by M3, M2, M1 on the ADF4116 family. Table VI shows the truth table.

### Phase Detector Polarity

DB7 (F2) of the function latch sets the Phase Detector Polarity. When the VCO characteristics are positive this should be set to “1.” When they are negative it should be set to “0.”

### Charge Pump Three-State

This bit puts the charge pump into three-state mode when programmed to a “1.” It should be set to “0” for normal operation.

### Fastlock Enable Bit

DB9 of the Function Latch is the Fastlock Enable Bit. Only when this is “1” is Fastlock enabled.

### Fastlock Mode Bit

DB11 of the Function Latch is the Fastlock Mode bit. When Fastlock is enabled, this bit determines which Fastlock Mode is used. If the Fastlock Mode bit is “0” then Fastlock Mode 1 is selected and if the Fastlock Mode bit is “1,” then Fastlock Mode 2 is selected.

If Fastlock is not enabled (DB9 = “0”), then DB11 (ADF4116) determines the state of the FL<sub>O</sub> output. FL<sub>O</sub> state will be the same as that programmed to DB11.

### Fastlock Mode 1

In the ADF4116 family, the output level of FL<sub>O</sub> is programmed to a low state and the charge pump current is switched to the high value (1 mA). FL<sub>O</sub> is used to switch a resistor in the loop filter and ensure stability while in Fastlock by altering the loop bandwidth.

The device enters Fastlock by having a “1” written to the CP Gain bit in the N register. The device exits Fastlock by having a “0” written to the CP Gain bit in the N register.

### Fastlock Mode 2

In the ADF4116 family, the output level of FL<sub>O</sub> is programmed to a low state and the charge pump current is switched to the high value (1 mA). FL<sub>O</sub> is used to switch a resistor in the loop filter and ensure stability while in Fastlock by altering the loop bandwidth.

The device enters Fastlock by having a “1” written to the CP Gain bit in the N register. The device exits Fastlock under the control of the Timer Counter. After the timeout period determined by the value in TC4–TC1, the CP Gain bit in the N register is automatically reset to “0” and the device reverts to normal mode instead of Fastlock.

### Timer Counter Control

In the ADF4116 family, the user has the option of switching between two charge pump current values to speed up locking to a new frequency.

When using the Fastlock feature with the ADF4116 family, the normal sequence of events is as follows:

The user must make sure that Fastlock is enabled. Set DB9 of the ADF4116 family to “1.” The user must also choose which Fastlock Mode to use. As discussed in the previous section, Fastlock Mode 2 uses the values in the Timer Counter to determine the timeout period before reverting to normal mode operation after Fastlock. Fastlock Mode 2 is chosen by setting DB11 of the ADF4116 family to “1.”

The user must also decide how long they want the high current (1 mA) to stay active before reverting to low current (250 μA). This is controlled by the Timer Counter Control Bits DB14 to DB11 (TC4–TC1) in the Function Latch. The truth table is given in Table VI.

Now, when the user wishes to program a new output frequency, they can simply program the A, B counter latch with new values for A and B. At the same time they can set the CP Gain bit to a “1,” which sets the charge pump 1 mA for a period of time determined by TC4–TC1. When this time is up, the charge pump current reverts to 250 μA. At the same time the CP Gain Bit in the A, B Counter latch is reset to 0 and is now ready for the next time that the user wishes to change the frequency again.

**The Initialization Latch**

When C2, C1 = 1, 1 then the Initialization Latch is programmed. This is essentially the same as the Function Latch (programmed when C2, C1 = 1, 0).

However, when the Initialization Latch is programmed there is an additional internal reset pulse applied to the R and N counters. This pulse ensures that the N counter is at load point when the N counter data is latched and the device will begin counting in close phase alignment.

If the Latch is programmed for synchronous power-down (CE pin is High; PD1 bit is High; PD2 bit is Low), the internal pulse also triggers this power-down. The prescaler reference and the oscillator input buffer are unaffected by the internal reset pulse and so close phase alignment is maintained when counting resumes.

When the first N counter data is latched after initialization, the internal reset pulse is again activated. However, successive N counter loads after this will not trigger the internal reset pulse.

**Device Programming After Initial Power-Up**

After initially powering up the device, there are three ways to program the device.

**Initialization Latch Method**

Apply  $V_{DD}$ .

Program the Initialization Latch ("11" in 2 LSBs of input word). Make sure that F1 bit is programmed to "0." Then do an R load ("00" in 2 LSBs). Then do an N load ("01" in 2 LSBs). When the Initialization Latch is loaded, the following occurs:

1. The function latch contents are loaded.
2. An internal pulse resets the R, N and timeout counters to load state conditions and also three-states the charge pump. Note that the prescaler bandgap reference and the oscillator input buffer are unaffected by the internal reset pulse, allowing close phase alignment when counting resumes.
3. Latching the first N counter data after the initialization word will activate the same internal reset pulse. Successive N loads will not trigger the internal reset pulse unless there is another initialization.

**The CE Pin Method**

Apply  $V_{DD}$ .

Bring CE low to put the device into power-down. This is an asynchronous power-down in that it happens immediately. Program the Function Latch (10). Program the R Counter Latch (00). Program the N Counter Latch (01). Bring CE high to take the device out of power-down. The R and N counter will now resume counting in close alignment.

Note that after CE goes high, a duration of 1  $\mu$ s may be required for the prescaler bandgap voltage and oscillator input buffer bias to reach steady state.

CE can be used to power the device up and down in order to check for channel activity. The input register does not need to be reprogrammed each time the device is disabled and enabled as long as it has been programmed at least once after  $V_{CC}$  was initially applied.

**The Counter Reset Method**

Apply  $V_{DD}$ .

Do a Function Latch Load ("10" in 2 LSBs). As part of this, load "1" to the F1 bit. This enables the counter reset. Do an R Counter Load ("00" in 2 LSBs). Do an N Counter Load ("01" in 2 LSBs). Do a Function Latch Load ("10" in 2 LSBs). As part of this, load "0" to the F1 bit. This disables the counter reset.

This sequence provides the same close alignment as the initialization method. It offers direct control over the internal reset. Note that counter reset holds the counters at load point and three-states the charge pump, but does not trigger synchronous power-down. The counter reset method requires an extra function latch load compared to the initialization latch method.



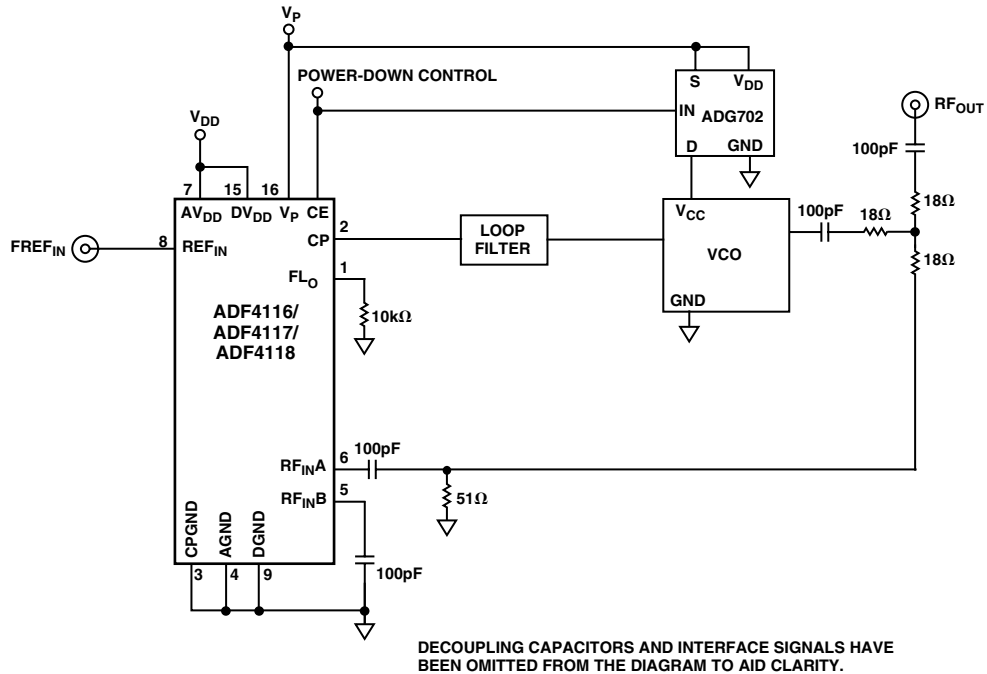

Figure 27. Local Oscillator Shutdown Circuit

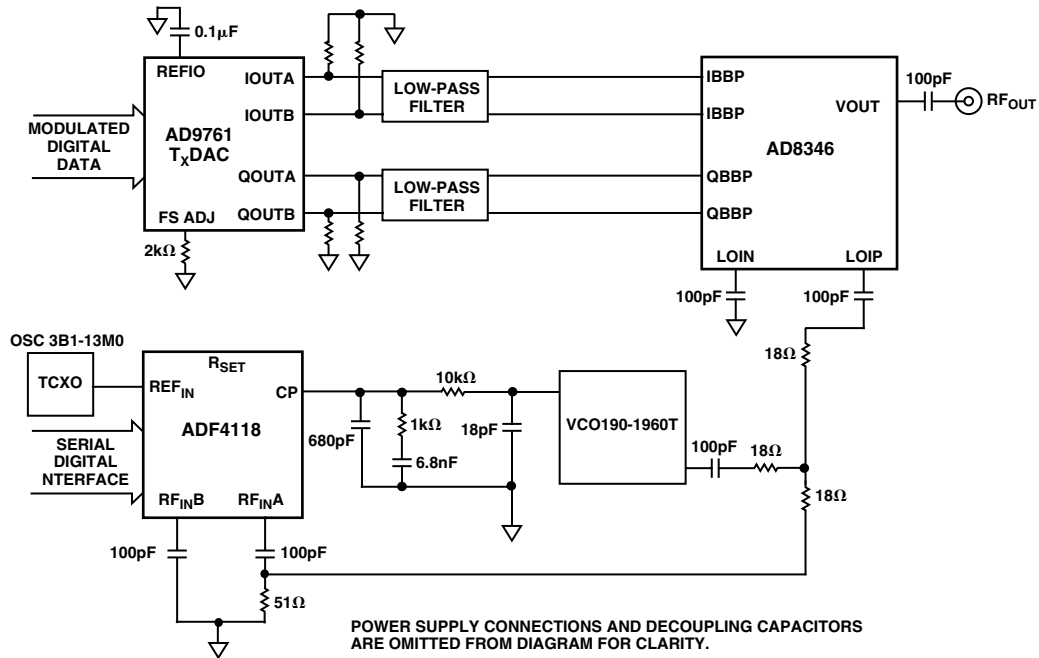

Figure 28. Direct Conversion Transmitter Solution

## INTERFACING

The ADF4116 family has a simple SPI-compatible serial interface for writing to the device. SCLK, SDATA and LE control the data transfer. When LE (Latch Enable) goes high, the 24 bits which have been clocked into the input register on each rising edge of SCLK will get transferred to the appropriate latch. See Figure 1 for the Timing Diagram and Table II for the Latch Truth Table.

The maximum allowable serial clock rate is 20 MHz. This means that the maximum update rate possible for the device is 833 kHz or one update every 1.2 microseconds. This is certainly more than adequate for systems which will have typical lock times in hundreds of microseconds.

# ADF4116/ADF4117/ADF4118

## ADuC812 Interface

Figure 29 shows the interface between the ADF4116 family and the ADuC812 microconverter. Since the ADuC812 is based on an 8051 core, this interface can be used with any 8051-based microcontroller. The microconverter is set up for SPI Master Mode with CPHA = 0. To initiate the operation, the I/O port driving LE is brought low. Each latch of the ADF4116 family needs a 24-bit word. This is accomplished by writing three 8-bit bytes from the microconverter to the device. When the third byte has been written the LE input should be brought high to complete the transfer.

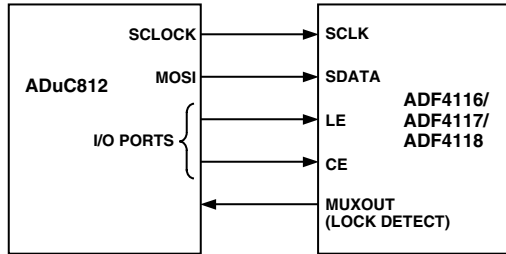

Figure 29. ADuC812 to ADF4116 Family Interface

On first applying power to the ADF4116 family, it needs three writes (one each to the R counter latch, the N counter latch and the initialization latch) for the output to become active.

I/O port lines on the ADuC812 are also used to control power-down (CE input) and to detect lock (MUXOUT configured as lock detect and polled by the port input).

When operating in the mode described, the maximum SCLOCK rate of the ADuC812 is 4 MHz. This means that the maximum rate at which the output frequency can be changed will be 166 kHz.

## ADSP-2181 Interface

Figure 30 shows the interface between the ADF4116 family and the ADSP-21xx Digital Signal Processor. The ADF4116 family needs a 21-bit serial word for each latch write. The easiest way to accomplish this using the ADSP-21xx family is to use the Autobuffered Transmit Mode of operation with Alternate Framing. This provides a means for transmitting an entire block of serial data before an interrupt is generated.

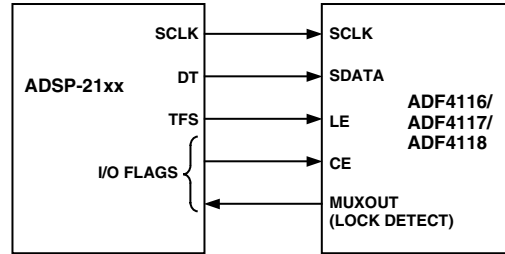

Figure 30. ADSP-21xx to ADF4116 Family Interface

Set up the word length for 8 bits and use three memory locations for each 24-bit word. To program each 21-bit latch, store the three 8-bit bytes, enable the Autobuffered mode and then write to the transmit register of the DSP. This last operation initiates the autobuffer transfer.

## OUTLINE DIMENSIONS

Dimensions shown in inches and (mm).

### Chip Scale (CP-20)

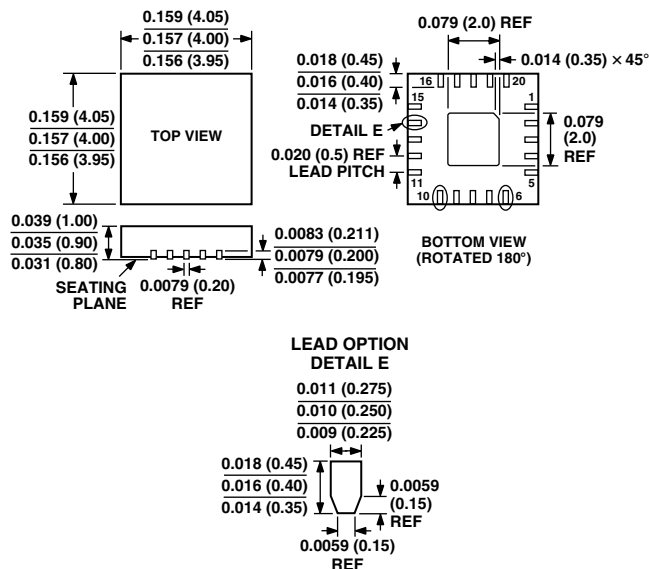

CONTROLLING DIMENSIONS ARE IN MILLIMETERS

### Thin Shrink Small Outline (RU-16)

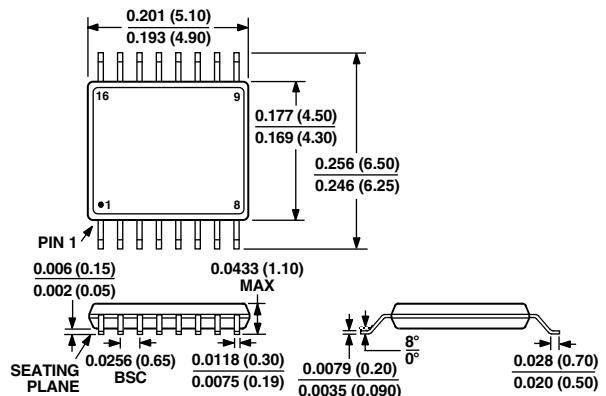



LittleDiode supplies new, hard to find or obsolete electronic components and semiconductors all over the world.

With over two million different components listed you are sure to find the part you need.

Feel free to visit us today at our online store:

[LittleDiode.com](http://LittleDiode.com)

Looking forward to providing you with the best possible service.