

ADG408/ADG409

FEATURES

44 V Supply Maximum Ratings
V_{SS} to V_{DD} Analog Signal Range
Low On Resistance (100 Ω max)
Low Power (I_{SUPPLY} < 75 μA)
Fast Switching
Break-Before-Make Switching Action
Plug-in Replacement for DG408/DG409

APPLICATIONS

Audio and Video Routing
Automatic Test Equipment
Data Acquisition Systems
Battery Powered Systems
Sample and Hold Systems
Communication Systems

GENERAL DESCRIPTION

The ADG408 and ADG409 are monolithic CMOS analog multiplexers comprising eight single channels and four differential channels respectively. The ADG408 switches one of eight inputs to a common output as determined by the 3-bit binary address lines A0, A1 and A2. The ADG409 switches one of four differential inputs to a common differential output as determined by the 2-bit binary address lines A0 and A1. An EN input on both devices is used to enable or disable the device. When disabled, all channels are switched OFF.

The ADG408/ADG409 are designed on an enhanced LC²MOS process which provides low power dissipation yet gives high switching speed and low on resistance. Each channel conducts equally well in both directions when ON and has an input signal range that extends to the supplies. In the OFF condition, signal levels up to the supplies are blocked. All channels exhibit break-before-make switching action, preventing momentary shorting when switching channels. Inherent in the design is low charge injection for minimum transients when switching the digital inputs.

The ADG408/ADG409 are improved replacements for the DG408/DG409 Analog Multiplexers.

REV. A

Information furnished by Analog Devices is believed to be accurate and reliable. However, no responsibility is assumed by Analog Devices for its use, nor for any infringements of patents or other rights of third parties which may result from its use. No license is granted by implication or otherwise under any patent or patent rights of Analog Devices.

FUNCTIONAL BLOCK DIAGRAMS

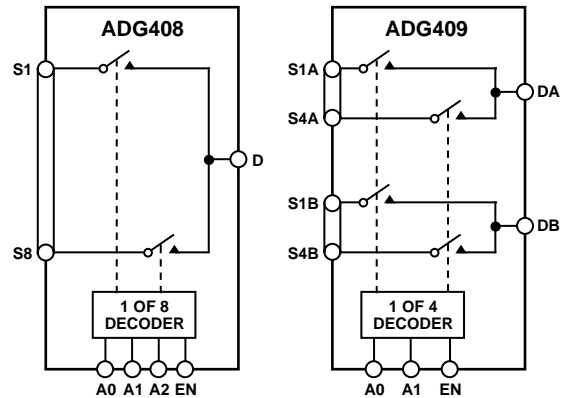

PRODUCT HIGHLIGHTS

- Extended Signal Range**
 The ADG408/ADG409 are fabricated on an enhanced LC²MOS process giving an increased signal range that extends to the supply rails.
- Low Power Dissipation**
- Low R_{ON}**
- Single Supply Operation**
 For applications where the analog signal is unipolar, the ADG408/ADG409 can be operated from a single rail power supply. The parts are fully specified with a single +12 V power supply and will remain functional with single supplies as low as +5 V.

ADG408/ADG409—SPECIFICATIONS

DUAL SUPPLY¹ ($V_{DD} = +15\text{ V}$, $V_{SS} = -15\text{ V}$, $GND = 0\text{ V}$, unless otherwise noted)

Parameter	B Version -40°C to +85°C		T Version -55°C to +125°C		Units	Test Conditions/Comments
	+25°C		+25°C			
ANALOG SWITCH						
Analogue Signal Range		V_{SS} to V_{DD}		V_{SS} to V_{DD}	V	
R_{ON}	40 100		40 100	125	Ω typ Ω max	$V_D = \pm 10\text{ V}$, $I_S = -10\text{ mA}$
ΔR_{ON}	15		15		Ω max	$V_D = +10\text{ V}$, -10 V
LEAKAGE CURRENTS						
Source OFF Leakage I_S (OFF)	± 0.5	± 50	± 0.5	± 50	nA max	$V_D = \pm 10\text{ V}$, $V_S = \mp 10\text{ V}$; Test Circuit 2
Drain OFF Leakage I_D (OFF)						$V_D = \pm 10\text{ V}$; $V_S = \mp 10\text{ V}$; Test Circuit 3
ADG408	± 1	± 100	± 1	± 100	nA max	
ADG409	± 1	± 50	± 1	± 50	nA max	
Channel ON Leakage I_D , I_S (ON)						$V_S = V_D = \pm 10\text{ V}$; Test Circuit 4
ADG408	± 1	± 100	± 1	± 100	nA max	
ADG409	± 1	± 50	± 1	± 50	nA max	
DIGITAL INPUTS						
Input High Voltage, V_{INH}		2.4		2.4	V min	
Input Low Voltage, V_{INL}		0.8		0.8	V max	
Input Current						
I_{INL} or I_{INH}		± 10		± 10	μA max	$V_{IN} = 0$ or V_{DD}
C_{IN} , Digital Input Capacitance	8		8		pF typ	$f = 1\text{ MHz}$
DYNAMIC CHARACTERISTICS ²						
$t_{TRANSITION}$		120 250		120 250	ns typ ns max	$R_L = 300\ \Omega$, $C_L = 35\text{ pF}$; $V_{S1} = \pm 10\text{ V}$, $V_{SS} = \mp 10\text{ V}$; Test Circuit 5
t_{OPEN}	10	10	10	10	ns min	$R_L = 300\ \Omega$, $C_L = 35\text{ pF}$; $V_S = +5\text{ V}$; Test Circuit 6
t_{ON} (EN)	85 150	125 225	85 150	125 225	ns typ ns max	$R_L = 300\ \Omega$, $C_L = 35\text{ pF}$; $V_S = +5\text{ V}$; Test Circuit 7
t_{OFF} (EN)		65 150		65 150	ns typ ns max	$R_L = 300\ \Omega$, $C_L = 35\text{ pF}$; $V_S = +5\text{ V}$; Test Circuit 7
Charge Injection	20		20		pC typ	$V_S = 0\text{ V}$, $R_S = 0\ \Omega$, $C_L = 10\text{ nF}$; Test Circuit 8
OFF Isolation	-75		-75		dB typ	$R_L = 1\text{ k}\Omega$, $f = 100\text{ kHz}$; $V_{EN} = 0\text{ V}$; Test Circuit 9
Channel-to-Channel Crosstalk	85		85		dB typ	$R_L = 1\text{ k}\Omega$, $f = 100\text{ kHz}$; Test Circuit 10
C_S (OFF)	11		11		pF typ	$f = 1\text{ MHz}$
C_D (OFF)						$f = 1\text{ MHz}$
ADG408	40		40		pF typ	
ADG409	20		20		pF typ	
C_D , C_S (ON)						$f = 1\text{ MHz}$
ADG408	54		54		pF typ	
ADG409	34		34		pF typ	
POWER REQUIREMENTS						
I_{DD}		1 5		1 5	μA typ μA max	$V_{IN} = 0\text{ V}$, $V_{EN} = 0\text{ V}$
I_{SS}		1 5		1 5	μA typ μA max	
I_{DD}	100 200		100 200	500	μA typ μA max	$V_{IN} = 0\text{ V}$, $V_{EN} = 2.4\text{ V}$

NOTES

¹Temperature ranges are as follows: B Version: -40°C to +85°C; T Version: -55°C to +125°C.

²Guaranteed by design, not subject to production test.

Specifications subject to change without notice.

SINGLE SUPPLY¹ ($V_{DD} = +12\text{ V}$, $V_{SS} = 0\text{ V}$, $GND = 0\text{ V}$, unless otherwise noted)

Parameter	B Version		T Version		Units	Test Conditions/Comments
	+25°C	-40°C to +85°C	+25°C	-55°C to +125°C		
ANALOG SWITCH						
Analog Signal Range		0 to V_{DD}		0 to V_{DD}	V	
R_{ON}	90		90		Ω typ	$V_D = +3\text{ V}$, $+10\text{ V}$, $I_S = -1\text{ mA}$
LEAKAGE CURRENTS						
Source OFF Leakage I_S (OFF)	± 0.5	± 50	± 0.5	± 50	nA max	$V_D = 8\text{ V}/0\text{ V}$, $V_S = 0\text{ V}/8\text{ V}$; Test Circuit 2
Drain OFF Leakage I_D (OFF)					nA max	$V_D = 8\text{ V}/0\text{ V}$, $V_S = 0\text{ V}/8\text{ V}$; Test Circuit 3
ADG408	± 1	± 100	± 1	± 100	nA max	
ADG409	± 1	± 50	± 1	± 50	nA max	
Channel ON Leakage I_D , I_S (ON)					nA max	$V_S = V_D = 8\text{ V}/0\text{ V}$; Test Circuit 4
ADG408	± 1	± 100	± 1	± 100	nA max	
ADG409	± 1	± 50	± 1	± 50	nA max	
DIGITAL INPUTS						
Input High Voltage, V_{INH}		2.4		2.4	V min	
Input Low Voltage, V_{INL}		0.8		0.8	V max	
Input Current					μA max	$V_{IN} = 0$ or V_{DD}
I_{INL} or I_{INH}		± 10		± 10	μA max	$f = 1\text{ MHz}$
C_{IN} , Digital Input Capacitance	8		8		pF typ	
DYNAMIC CHARACTERISTICS²						
$t_{TRANSITION}$	130		130		ns typ	$R_L = 300\ \Omega$, $C_L = 35\text{ pF}$; $V_{S1} = 8\text{ V}/0\text{ V}$, $V_{SS} = 0\text{ V}/8\text{ V}$; Test Circuit 5
t_{OPEN}	10		10		ns typ	$R_L = 300\ \Omega$, $C_L = 35\text{ pF}$; $V_S = +5\text{ V}$; Test Circuit 6
t_{ON} (EN)	140		140		ns typ	$R_L = 300\ \Omega$, $C_L = 35\text{ pF}$; $V_S = +5\text{ V}$; Test Circuit 7
t_{OFF} (EN)	60		60		ns typ	$R_L = 300\ \Omega$, $C_L = 35\text{ pF}$; $V_S = +5\text{ V}$; Test Circuit 7
Charge Injection	5		5		pC typ	$V_S = 0\text{ V}$, $R_S = 0\ \Omega$, $C_L = 10\text{ nF}$; Test Circuit 8
OFF Isolation	-75		-75		dB typ	$R_L = 1\text{ k}\Omega$, $f = 100\text{ kHz}$; $V_{EN} = 0\text{ V}$; Test Circuit 9
Channel-to-Channel Crosstalk	85		85		dB typ	$R_L = 1\text{ k}\Omega$, $f = 100\text{ kHz}$; Test Circuit 10
C_S (OFF)	11		11		pF typ	$f = 1\text{ MHz}$
C_D (OFF)					pF typ	$f = 1\text{ MHz}$
ADG408	40		40		pF typ	
ADG409	20		20		pF typ	
C_D , C_S (ON)					pF typ	$f = 1\text{ MHz}$
ADG408	54		54		pF typ	
ADG409	34		34		pF typ	
POWER REQUIREMENTS						
I_{DD}		1		1	μA typ	$V_{IN} = 0\text{ V}$, $V_{EN} = 0\text{ V}$
		5		5	μA max	
I_{DD}	100		100		μA typ	$V_{IN} = 0\text{ V}$, $V_{EN} = 2.4\text{ V}$
	200	500	200	500	μA max	

NOTES

¹Temperature ranges are as follows: B Version: -40°C to +85°C; T Version: -55°C to +125°C.

²Guaranteed by design, not subject to production test.

Specifications subject to change without notice.

ADG408/ADG409

ABSOLUTE MAXIMUM RATINGS¹

(T_A = +25°C unless otherwise noted)

V _{DD} to V _{SS}	+44 V
V _{DD} to GND	-0.3 V to +25 V
V _{SS} to GND	+0.3 V to -25 V
Analog, Digital Inputs ²	V _{SS} -2 V to V _{DD} +2 V or 20 mA, Whichever Occurs First
Continuous Current, S or D	20 mA
Peak Current, S or D (Pulsed at 1 ms, 10% Duty Cycle max)	40 mA
Operating Temperature Range	
Industrial (B Version)	-40°C to +85°C
Extended (T Version)	-55°C to +125°C
Storage Temperature Range	-65°C to +150°C
Junction Temperature	+150°C
Cerdip Package, Power Dissipation	900 mW
θ _{JA} , Thermal Impedance	76°C/W
Lead Temperature, Soldering (10 sec)	+300°C
Plastic Package, Power Dissipation	470 mW
θ _{JA} , Thermal Impedance	117°C/W
Lead Temperature, Soldering (10 sec)	+260°C
TSSOP Package, Power Dissipation	450 mW
θ _{JA} , Thermal Impedance	155°C/W
θ _{JC} , Thermal Impedance	50°C/W
SOIC Package, Power Dissipation	600 mW
θ _{JA} , Thermal Impedance	77°C/W
Lead Temperature, Soldering	
Vapor Phase (60 sec)	+215°C
Infrared (15 sec)	+220°C

NOTES

¹Stresses above those listed under Absolute Maximum Ratings may cause permanent damage to the device. This is a stress rating only; functional operation of the device at these or any other conditions above those listed in the operational sections of this specification is not implied. Exposure to absolute maximum rating conditions for extended periods may affect device reliability. Only one absolute maximum rating may be applied at any one time.

²Overvoltages at A, EN, S or D will be clamped by internal diodes. Current should be limited to the maximum ratings given.

CAUTION

ESD (electrostatic discharge) sensitive device. Electrostatic charges as high as 4000 V readily accumulate on the human body and test equipment and can discharge without detection. Although the ADG408/ADG409 feature proprietary ESD protection circuitry, permanent damage may occur on devices subjected to high energy electrostatic discharges. Therefore, proper ESD precautions are recommended to avoid performance degradation or loss of functionality.

ORDERING INFORMATION

Model ¹	Temperature Range	Package Option ²
ADG408BN	-40°C to +85°C	N-16
ADG408BR	-40°C to +85°C	R-16A
ADG408BRU	-40°C to +85°C	RU-16
ADG408TQ	-55°C to +125°C	Q-16
ADG409BN	-40°C to +85°C	N-16
ADG409BR	-40°C to +85°C	R-16A
ADG409TQ	-55°C to +125°C	Q-16

NOTES

¹To order MIL-STD-883, Class B processed parts, add /883B to T grade part numbers.

²N = Plastic DIP; Q = Cerdip; R = 0.15" Small Outline IC (SOIC);
RU = Think Shrink Small Outline Package (TSSOP).



PIN CONFIGURATIONS (DIP/SOIC/TSSOP)

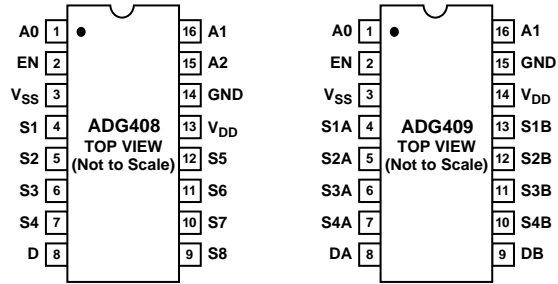

ADG408 Truth Table

A2	A1	A0	EN	ON SWITCH
X	X	X	0	NONE
0	0	0	1	1
0	0	1	1	2
0	1	0	1	3
0	1	1	1	4
1	0	0	1	5
1	0	1	1	6
1	1	0	1	7
1	1	1	1	8

ADG409 Truth Table

A1	A0	EN	ON SWITCH PAIR
X	X	0	NONE
0	0	1	1
0	1	1	2
1	0	1	3
1	1	1	4

TERMINOLOGY

V_{DD}	Most positive power supply potential.
V_{SS}	Most negative power supply potential in dual supplies. In single supply applications, it may be connected to ground.
GND	Ground (0 V) reference.
R_{ON}	Ohmic resistance between D and S.
ΔR_{ON}	Difference between the R_{ON} of any two channels.
I_S (OFF)	Source leakage current when the switch is off.
I_D (OFF)	Drain leakage current when the switch is off.
I_{D, I_S} (ON)	Channel leakage current when the switch is on.
V_D (V_S)	Analog voltage on terminals D, S.
C_S (OFF)	Channel input capacitance for “OFF” condition.
C_D (OFF)	Channel output capacitance for “OFF” condition.
C_{D, C_S} (ON)	“ON” switch capacitance.
C_{IN}	Digital input capacitance.
t_{ON} (EN)	Delay time between the 50% and 90% points of the digital input and switch “ON” condition.
t_{OFF} (EN)	Delay time between the 50% and 90% points of the digital input and switch “OFF” condition.
$t_{TRANSITION}$	Delay time between the 50% and 90% points of the digital inputs and the switch “ON” condition when switching from one address state to another.
t_{OPEN}	“OFF” time measured between the 80% point of both switches when switching from one address state to another.
V_{INL}	Maximum input voltage for Logic “0.”
V_{INH}	Minimum input voltage for Logic “1.”
I_{INL} (I_{INH})	Input current of the digital input.
Crosstalk	A measure of unwanted signal which is coupled through from one channel to another as a result of parasitic capacitance.
Off Isolation	A measure of unwanted signal coupling through an “OFF” channel.
Charge Injection	A measure of the glitch impulse transferred from the digital input to the analog output during switching.
I_{DD}	Positive supply current.
I_{SS}	Negative supply current.

ADG408/ADG409

Typical Performance Characteristics

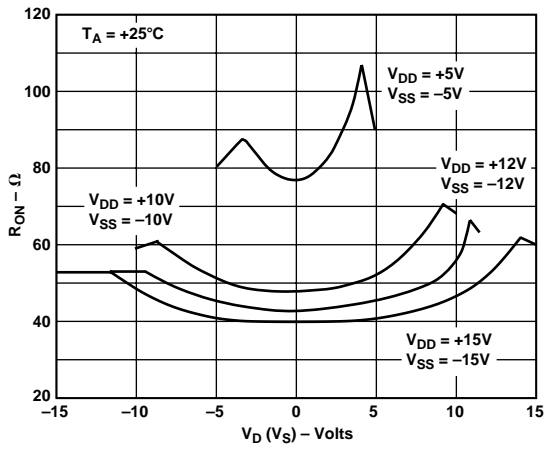

Figure 1. R_{ON} as a Function of V_D (V_S): Dual Supply Voltage

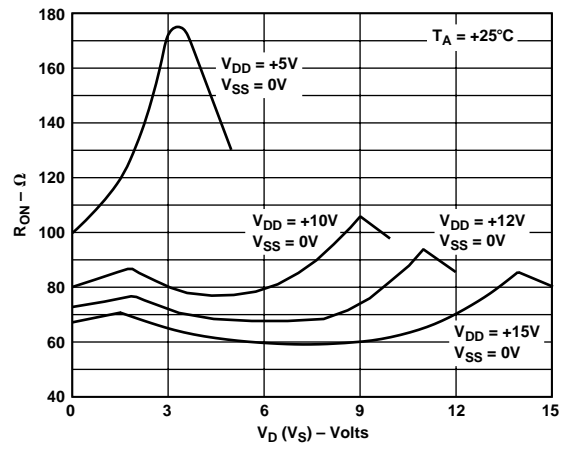

Figure 4. R_{ON} as a Function of V_D (V_S): Single Supply Voltage

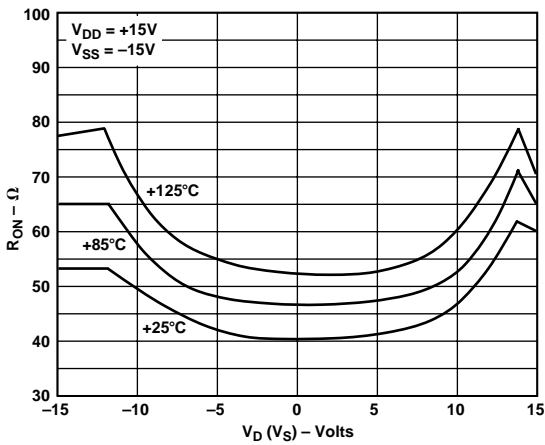

Figure 2. R_{ON} as a Function of V_D (V_S) for Different Temperatures

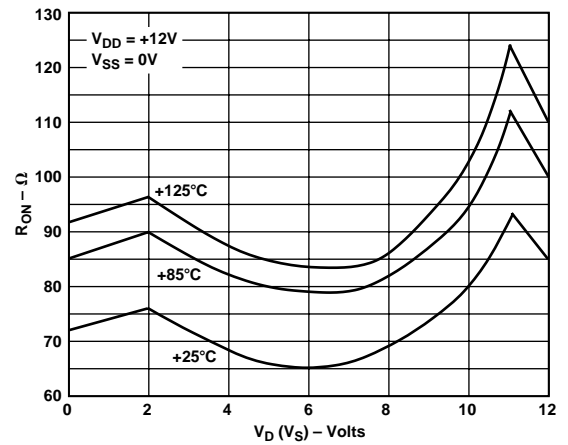

Figure 5. R_{ON} as a Function of V_D (V_S) for Different Temperatures

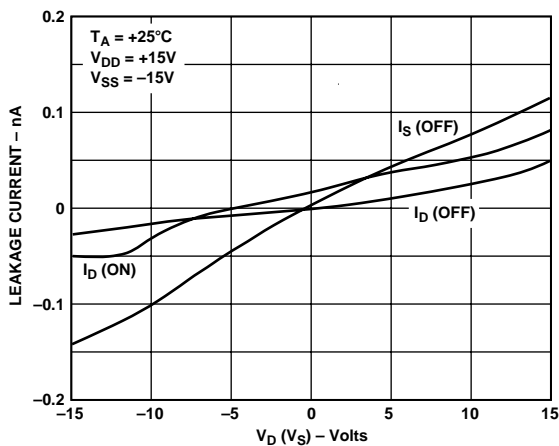

Figure 3. Leakage Currents as a Function of V_D (V_S)

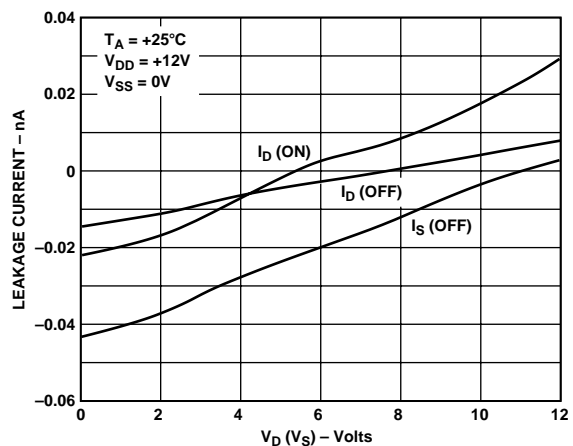

Figure 6. Leakage Currents as a Function of V_D (V_S)

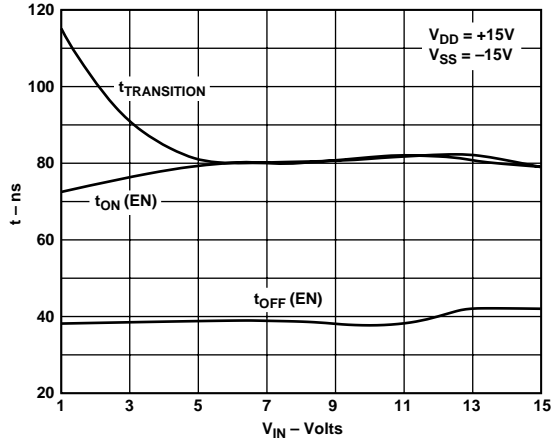

Figure 7. Switching Time vs. V_{IN} (Bipolar Supply)

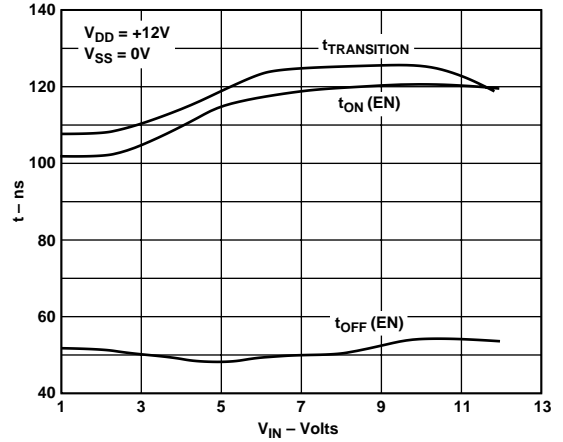

Figure 10. Switching Time vs. V_{IN} (Single Supply)

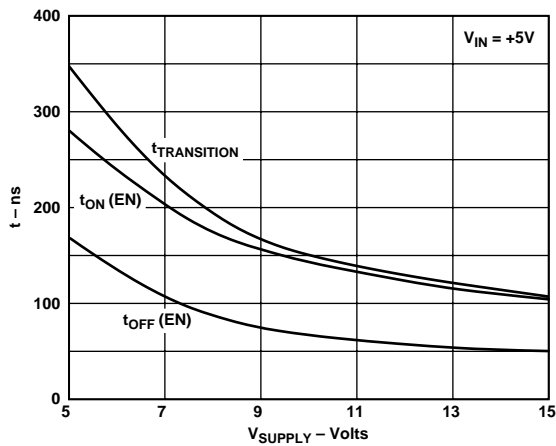

Figure 8. Switching Time vs. Single Supply

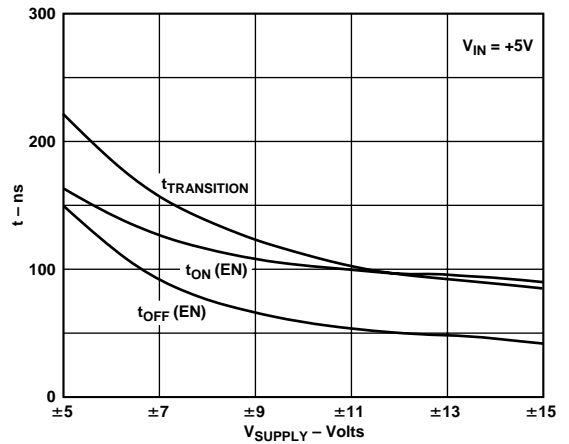

Figure 11. Switching Time vs. Bipolar Supply

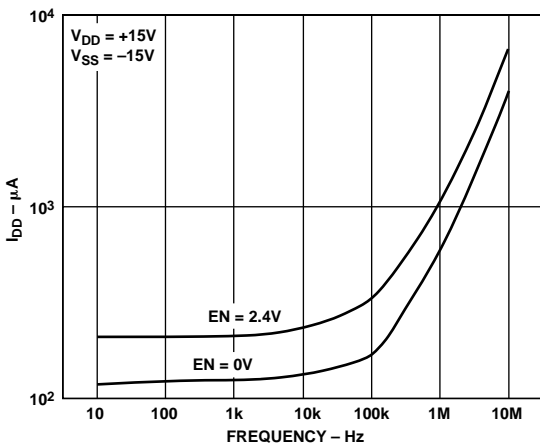

Figure 9. Positive Supply Current vs. Switching Frequency

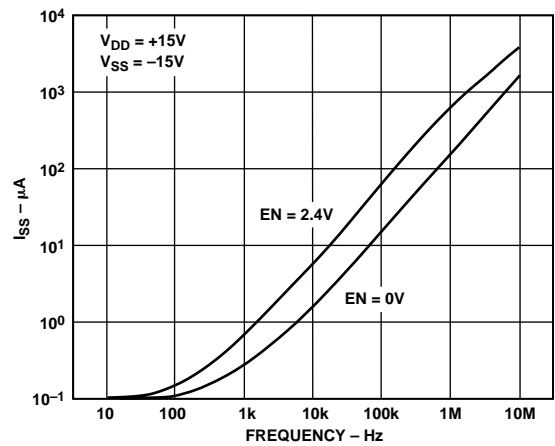

Figure 12. Negative Supply Current vs. Switching Frequency

ADG408/ADG409

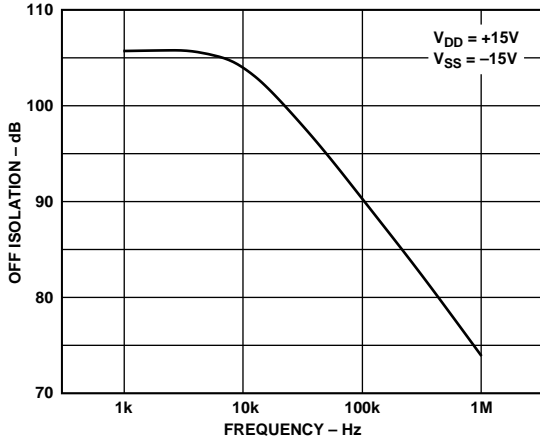

Figure 13. Off Isolation vs. Frequency

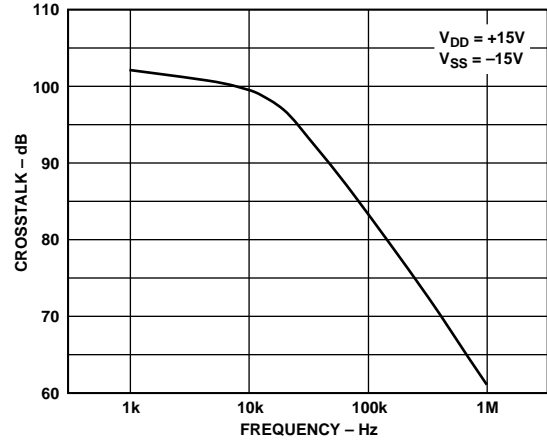
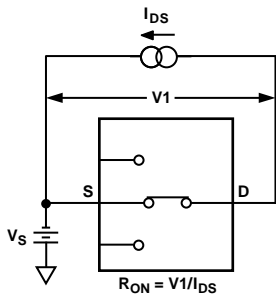
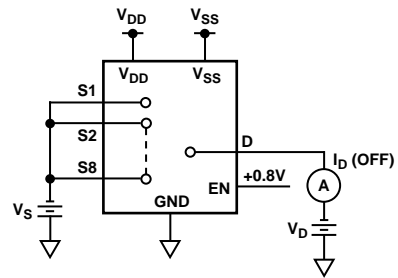

Figure 14. Crosstalk vs. Frequency

Test Circuits



Test Circuit 1. On Resistance



Test Circuit 3. I_D (OFF)

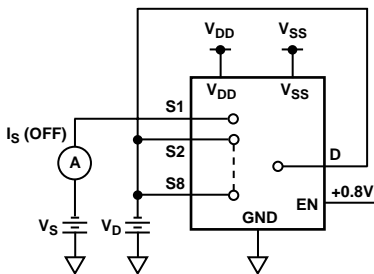

Test Circuit 2. I_S (OFF)

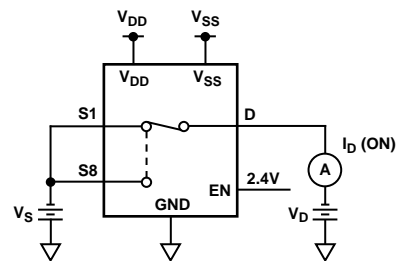

Test Circuit 4. I_D (ON)

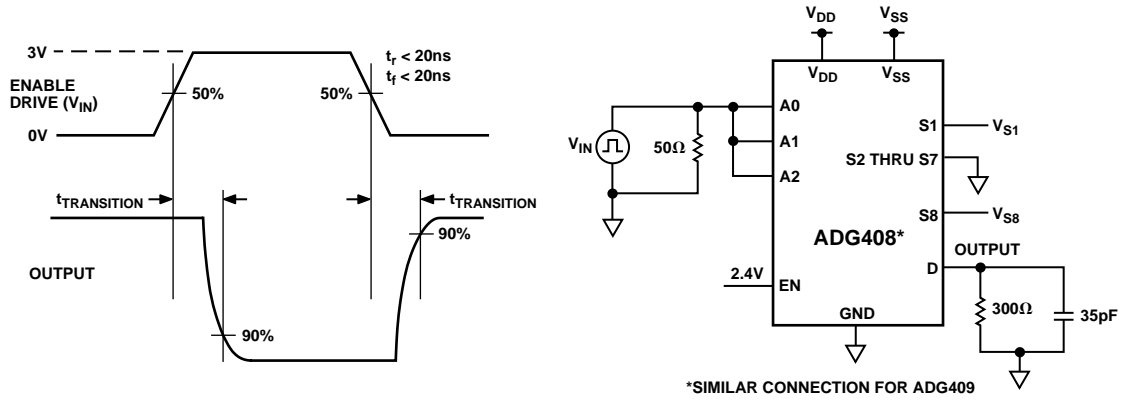

Test Circuit 5. Switching Time of Multiplexer, $t_{\text{TRANSITION}}$

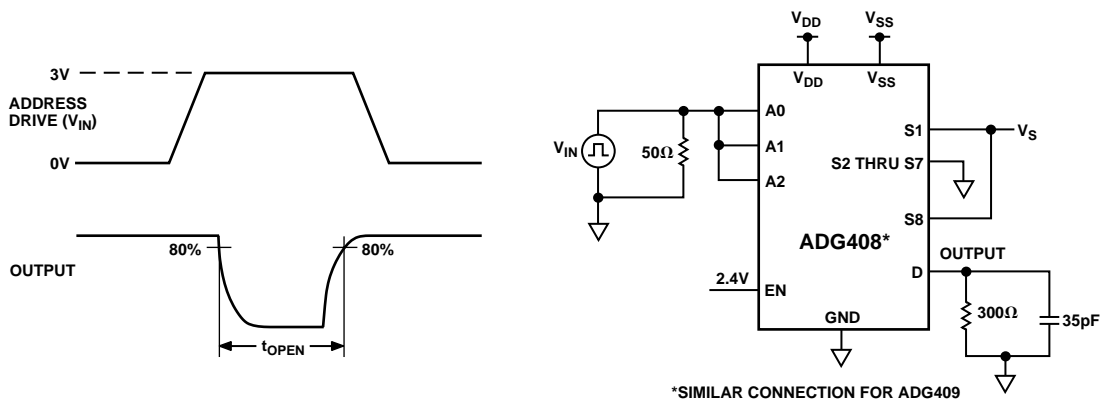

Test Circuit 6. Break-Before-Make Delay, t_{OPEN}

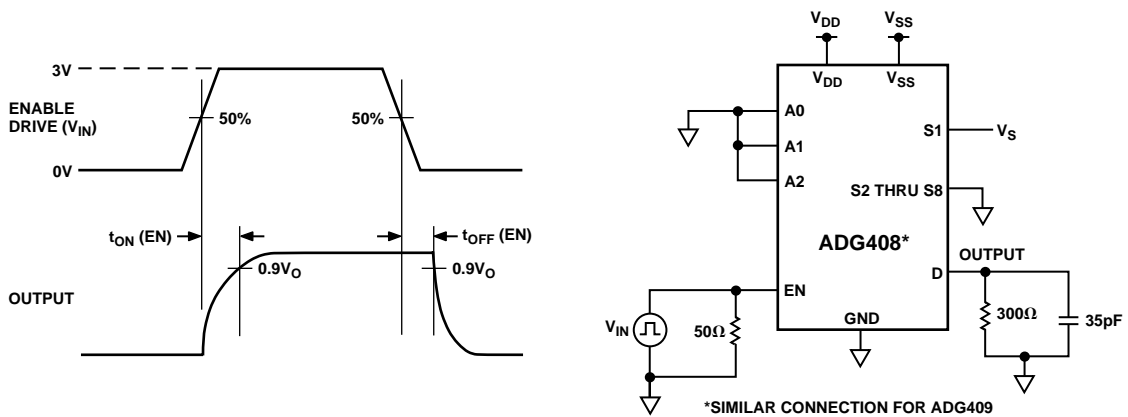

Test Circuit 7. Enable Delay, $t_{\text{ON}}(\text{EN})$, $t_{\text{OFF}}(\text{EN})$

ADG408/ADG409

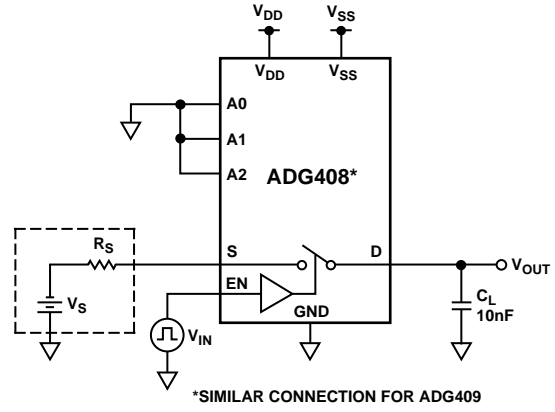
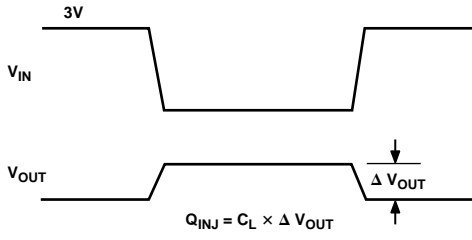

Test Circuit 8. Charge Injection

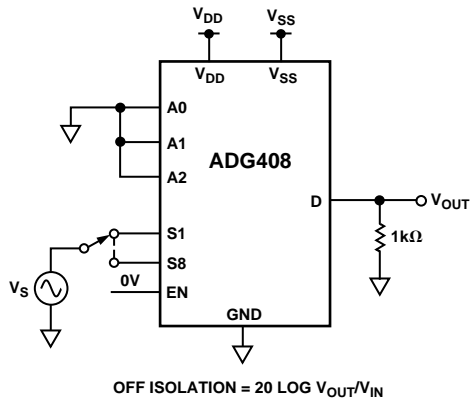

Test Circuit 9. OFF Isolation

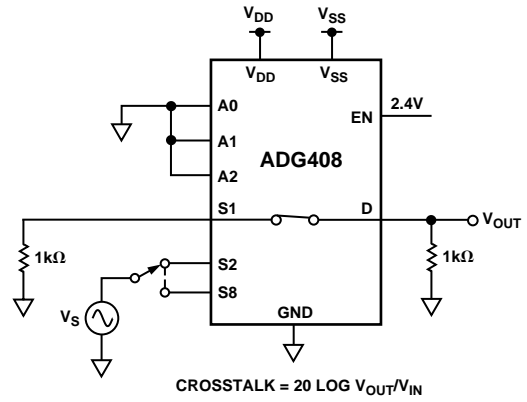

Test Circuit 10. Channel-to-Channel Crosstalk

OUTLINE DIMENSIONS
Dimensions shown in inches and (mm).

Plastic DIP (N-16)

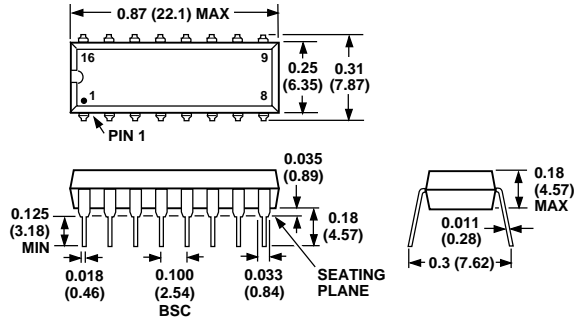

SO (Narrow Body) (R-16A)

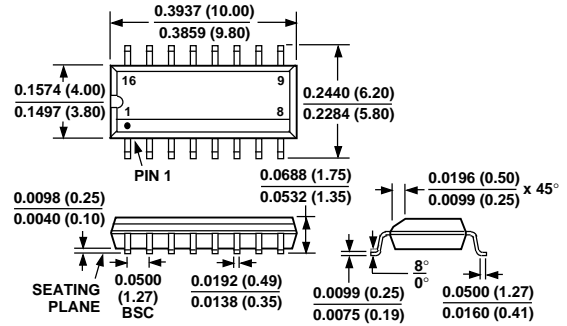

Cerdip (Q-16)

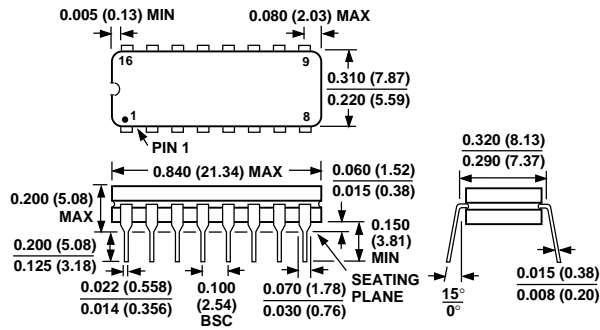

Thin Shrink Small Outline Package (TSSOP) (RU-16)

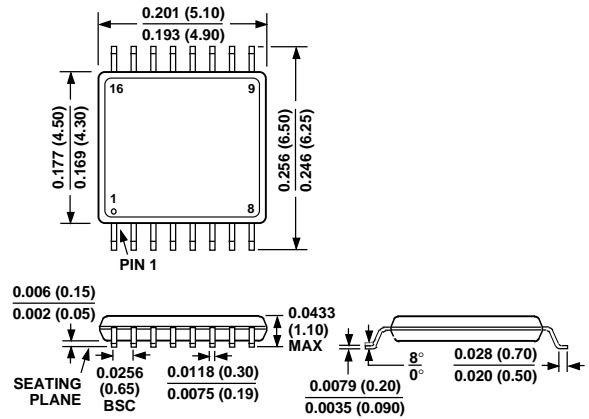

C1824a-0-4/98

PRINTED IN U.S.A.



LittleDiode supplies new, hard to find or obsolete electronic components and semiconductors all over the world.

With over two million different components listed you are sure to find the part you need.

Feel free to visit us today at our online store:

LittleDiode.com

Looking forward to providing you with the best possible service.