

ADG661/ADG662/ADG663

FEATURES

- +5 V, ± 5 V Power Supplies
- Ultralow Power Dissipation ($<0.5 \mu\text{W}$)
- Low Leakage ($<100 \text{ pA}$)
- Low On Resistance ($<50 \Omega$)
- Fast Switching Times
- Low Charge Injection
- TTL/CMOS Compatible
- TSSOP Package

APPLICATIONS

- Battery Powered Instruments
- Single Supply Systems
- Remote Powered Equipment
- +5 V Supply Systems
- Computer Peripherals such as Disk Drives
- Precision Instrumentation
- Audio and Video Switching
- Automatic Test Equipment
- Precision Data Acquisition
- Sample Hold Systems
- Communication Systems

GENERAL DESCRIPTION

The ADG661, ADG662 and ADG663 are monolithic CMOS devices comprising four independently selectable switches. These switches feature low, well-controlled on resistance and wide analog signal range, making them ideal for precision analog signal switching.

They are fabricated using Analog Devices' advanced linear compatible CMOS (LC²MOS) process, which offers benefits of low leakage currents, ultralow power dissipation and low capacitance for fast switching speeds with minimum charge injection.

The on resistance profile is very flat over the full analog input range ensuring excellent linearity and low distortion when switching audio signals. Fast switching speed coupled with high signal bandwidth also make the parts suitable for video signal switching. CMOS construction ensures ultralow power dissipation making the parts ideally suited for portable and battery powered instruments.

The ADG661, ADG662 and ADG663 contain four independent SPST switches. The ADG661 and ADG662 differ only in that the digital control logic is inverted. The ADG661 switches are turned on with a logic low on the appropriate control input, while a logic high is required for the ADG662. The ADG663 has two switches with digital control logic similar to that of the ADG661, while the logic is inverted on the other two switches.

REV. 0

Information furnished by Analog Devices is believed to be accurate and reliable. However, no responsibility is assumed by Analog Devices for its use, nor for any infringements of patents or other rights of third parties which may result from its use. No license is granted by implication or otherwise under any patent or patent rights of Analog Devices.

FUNCTIONAL BLOCK DIAGRAM

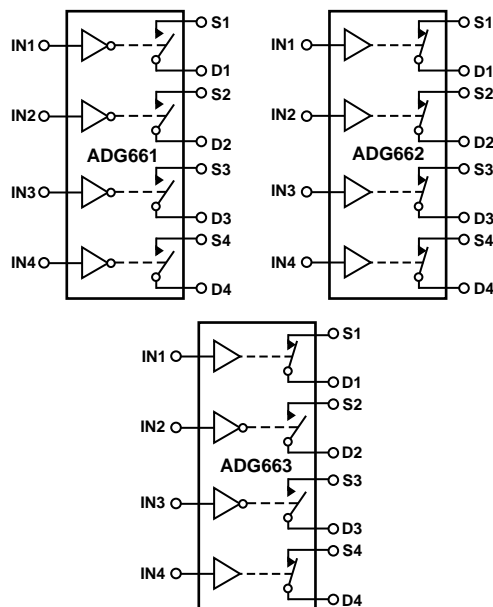

SWITCHES SHOWN FOR A LOGIC "1" INPUT

Each switch conducts equally well in both directions when ON and has an input signal range that extends to the supplies. In the OFF condition, signal levels up to the supplies are blocked. All switches exhibit break-before-make switching action for use in multiplexer applications. Inherent in the design is low charge injection for minimum transients when switching the digital inputs.

PRODUCT HIGHLIGHTS

1. +5 V Single Supply Operation
The ADG661, ADG662 and ADG663 offer high performance, including low on resistance and wide signal range, fully specified and guaranteed with ± 5 V and +5 V supply rails.
2. Ultralow Power Dissipation
CMOS construction ensures ultralow power dissipation.
3. Low R_{ON}
4. Break-Before-Make Switching
This prevents channel shorting when the switches are configured as a multiplexer.

ADG661/ADG662/ADG663—SPECIFICATIONS¹

Dual Supply ($V_{DD} = +5\text{ V} \pm 10\%$, $V_{SS} = -5\text{ V} \pm 10\%$, $GND = 0\text{ V}$, unless otherwise noted)

Parameter	B Versions		Units	Test Conditions/Comments
	+25°C	-40°C to +85°C		
ANALOG SWITCH				
Analogue Signal Range		V_{DD} to V_{SS}	V	
R_{ON}	30 38	50	Ω typ Ω max	$V_D = -3.5\text{ V}$ to $+3.5\text{ V}$, $I_S = -10\text{ mA}$; $V_{DD} = +4.5\text{ V}$, $V_{SS} = -4.5\text{ V}$
LEAKAGE CURRENTS				
Source OFF Leakage I_S (OFF)	± 0.025 ± 0.1	± 2.5	nA typ nA max	$V_{DD} = +5.5\text{ V}$, $V_{SS} = -5.5\text{ V}$ $V_D = \pm 4.5\text{ V}$, $V_S = \pm 4.5\text{ V}$; Test Circuit 2
Drain OFF Leakage I_D (OFF)	± 0.025 ± 0.1	± 2.5	nA typ nA max	$V_D = \pm 4.5\text{ V}$, $V_S = \pm 4.5\text{ V}$; Test Circuit 2
Channel ON Leakage I_D , I_S (ON)	± 0.05 ± 0.2	± 5	nA typ nA max	$V_D = V_S = \pm 4.5\text{ V}$; Test Circuit 3
DIGITAL INPUTS				
Input High Voltage, V_{INH}		2.4	V min	
Input Low Voltage, V_{INL}		0.8	V max	
Input Current I_{INL} or I_{INH}	0.005	± 0.1	μA typ μA max	$V_{IN} = V_{INL}$ or V_{INH}
DYNAMIC CHARACTERISTICS²				
t_{ON}	150	275	ns typ ns max	$R_L = 300\ \Omega$, $C_L = 35\text{ pF}$; $V_S = \pm 3\text{ V}$; Test Circuit 4
t_{OFF}	55	120	ns typ ns max	$R_L = 300\ \Omega$, $C_L = 35\text{ pF}$; $V_S = \pm 3\text{ V}$; Test Circuit 4
Break-Before-Make Time Delay, t_D (ADG663 Only)	80		ns typ	$R_L = 300\ \Omega$, $C_L = 35\text{ pF}$; $V_{S1} = V_{S2} = +3\text{ V}$; Test Circuit 5
Charge Injection	6		pC typ	$V_S = 0\text{ V}$, $R_S = 0\ \Omega$, $C_L = 10\text{ nF}$; Test Circuit 6
OFF Isolation	70		dB typ	$R_L = 50\ \Omega$, $C_L = 5\text{ pF}$, $f = 1\text{ MHz}$; Test Circuit 7
Channel-to-Channel Crosstalk	90		dB typ	$R_L = 50\ \Omega$, $C_L = 5\text{ pF}$, $f = 1\text{ MHz}$; Test Circuit 8
C_S (OFF)	9		pF typ	$f = 1\text{ MHz}$
C_D (OFF)	9		pF typ	$f = 1\text{ MHz}$
C_D , C_S (ON)	28		pF typ	$f = 1\text{ MHz}$
POWER REQUIREMENTS				
V_{DD}		+4.5/5.5 -4.5/5.5	V min/max V min/max	
I_{DD}	0.0001	1	μA typ μA max	$V_{DD} = +5.5\text{ V}$, $V_{SS} = -5.5\text{ V}$ Digital Inputs = 0 V or 5 V
I_{SS}	0.0001	1	μA typ μA max	

NOTES

¹Temperature ranges are as follows: B Versions, -40°C to +85°C.

²Guaranteed by design, not subject to production test.

Specifications subject to change without notice.

Single Supply ($V_{DD} = +5\text{ V} \pm 10\%$, $V_{SS} = 0\text{ V}$, $GND = 0\text{ V}$, unless otherwise noted)

Parameter	B Versions		Units	Test Conditions/Comments
	+25°C	-40°C to +85°C		
ANALOG SWITCH Analog Signal Range R_{ON}	45 68	0 V to V_{DD} 75	V Ω typ Ω max	$V_D = 0\text{ V}$ to $+3.5\text{ V}$, $I_S = -10\text{ mA}$; $V_{DD} = +4.5\text{ V}$
LEAKAGE CURRENTS Source OFF Leakage I_S (OFF) Drain OFF Leakage I_D (OFF) Channel ON Leakage I_D, I_S (ON)	± 0.025 ± 0.1 ± 0.025 ± 0.1 ± 0.05 ± 0.2	± 2.5 ± 2.5 ± 5	nA typ nA max nA typ nA max nA typ nA max	$V_{DD} = +5.5\text{ V}$ $V_D = 4.5\text{ V}/1\text{ V}$, $V_S = 1\text{ V}/4.5\text{ V}$; Test Circuit 2 $V_D = 4.5\text{ V}/1\text{ V}$, $V_S = 1\text{ V}/4.5\text{ V}$; Test Circuit 2 $V_D = V_S = +4.5\text{ V}/+1\text{ V}$; Test Circuit 3
DIGITAL INPUTS Input High Voltage, V_{INH} Input Low Voltage, V_{INL} Input Current I_{INL} or I_{INH}	0.005	2.4 0.8 ± 0.1	V min V max μA typ μA max	$V_{IN} = V_{INL}$ or V_{INH}
DYNAMIC CHARACTERISTICS ² t_{ON} t_{OFF} Break-Before-Make Time Delay, t_D (ADG663 Only) Charge Injection OFF Isolation Channel-to-Channel Crosstalk C_S (OFF) C_D (OFF) C_D, C_S (ON)	250 45 140 12 70 90 9 9 28	400 100	ns typ ns max ns typ ns max ns typ pC typ dB typ dB typ pF typ pF typ pF typ	$R_L = 300\ \Omega$, $C_L = 35\text{ pF}$; $V_S = +2\text{ V}$; Test Circuit 4 $R_L = 300\ \Omega$, $C_L = 35\text{ pF}$; $V_S = +2\text{ V}$; Test Circuit 4 $R_L = 300\ \Omega$, $C_L = 35\text{ pF}$; $V_{S1} = V_{S2} = +2\text{ V}$; Test Circuit 5 $V_S = 0\text{ V}$, $R_S = 0\ \Omega$, $C_L = 10\text{ nF}$; Test Circuit 6 $R_L = 50\ \Omega$, $C_L = 5\text{ pF}$, $f = 1\text{ MHz}$; Test Circuit 7 $R_L = 50\ \Omega$, $C_L = 5\text{ pF}$, $f = 1\text{ MHz}$; Test Circuit 8 $f = 1\text{ MHz}$ $f = 1\text{ MHz}$ $f = 1\text{ MHz}$
POWER REQUIREMENTS V_{DD} I_{DD}	0.0001	+4.5/5.5 1	V min/max μA typ μA max	$V_{DD} = +5.5\text{ V}$ Digital Inputs = 0 V or 5 V

NOTES

¹Temperature ranges are as follows: B Versions, -40°C to +85°C.²Guaranteed by design, not subject to production test.

Specifications subject to change without notice.

ADG661/ADG662/ADG663

ABSOLUTE MAXIMUM RATINGS¹

(T_A = +25°C unless otherwise noted)

V _{DD} to V _{SS}	+44 V
V _{DD} to GND	-0.3 V to +25 V
V _{SS} to GND	+0.3 V to -25 V
Analog, Digital Inputs ²	V _{SS} -2 V to V _{DD} +2 V or 30 mA, Whichever Occurs First
Continuous Current, S or D	30 mA
Peak Current, S or D	100 mA (Pulsed at 1 ms, 10% Duty Cycle max)
Operating Temperature Range	
Industrial (B Version)	-40°C to +85°C
Storage Temperature Range	-65°C to +150°C
Junction Temperature	+150°C
TSSOP Package, Power Dissipation	450 mW
θ _{JA} Thermal Impedance	115°C/W
θ _{JC} Thermal Impedance	35°C/W

Lead Temperature, Soldering

Vapor Phase (60 secs)	+215°C
Infrared (15 secs)	+220°C

NOTES

¹Stresses above those listed under Absolute Maximum Ratings may cause permanent damage to the device. This is a stress rating only; functional operation of the device at these or any other conditions above those listed in the operational sections of this specification is not implied. Exposure to absolute maximum rating conditions for extended periods may affect device reliability. Only one absolute maximum rating may be applied at any one time.

²Overvoltages at IN, S or D will be clamped by internal diodes. Current should be limited to the maximum ratings given.

ORDERING GUIDE

Model	Temperature Range	Package Description	Package Option
ADG661BRU	-40°C to +85°C	16-Lead TSSOP	RU-16
ADG662BRU	-40°C to +85°C	16-Lead TSSOP	RU-16
ADG663BRU	-40°C to +85°C	16-Lead TSSOP	RU-16

CAUTION

ESD (electrostatic discharge) sensitive device. Electrostatic charges as high as 4000 V readily accumulate on the human body and test equipment and can discharge without detection. Although the ADG661/ADG662/ADG663 features proprietary ESD protection circuitry, permanent damage may occur on devices subjected to high energy electrostatic discharges. Therefore, proper ESD precautions are recommended to avoid performance degradation or loss of functionality.



PIN CONFIGURATION

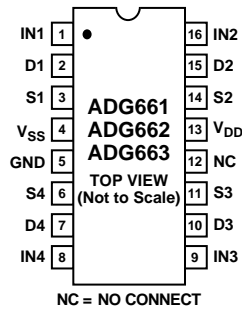

Table I. Truth Table (ADG661/ADG662)

ADG661 In	ADG662 In	Switch Condition
0	1	ON
1	0	OFF

Table II. Truth Table (ADG663)

Logic	Switch 1, 4	Switch 2, 3
0	OFF	ON
1	ON	OFF

TERMINOLOGY

V_{DD}	Most positive power supply potential.
V_{SS}	Most negative power supply potential in dual supplies. In single supply applications, it may be connected to GND.
GND	Ground (0 V) Reference.
S	Source Terminal. May be an input or output.
D	Drain Terminal. May be an input or output.
IN	Logic Control Input.
R_{ON}	Ohmic resistance between D and S.
I_S (OFF)	Source leakage current with the switch "OFF."
I_D (OFF)	Drain leakage current with the switch "OFF."
I_D, I_S (ON)	Channel leakage current with the switch "ON."
V_D (V_S)	Analog voltage on terminals D, S.
C_S (OFF)	"OFF" Switch Source Capacitance.
C_D (OFF)	"OFF" Switch Drain Capacitance.
C_D, C_S (ON)	"ON" Switch Capacitance.
t_{ON}	Delay between applying the digital control input and the output switching on.
t_{OFF}	Delay between applying the digital control input and the output switching off.
t_D	"OFF" time or "ON" time measured between the 90% points of both switches, when switching from one address state to another.
Crosstalk	A measure of unwanted signal which is coupled through from one channel to another as a result of parasitic capacitance.
Off Isolation	A measure of unwanted signal coupling through an "OFF" switch.
Charge Injection	A measure of the glitch impulse transferred from the digital input to analog output during switching.

Typical Performance Characteristics

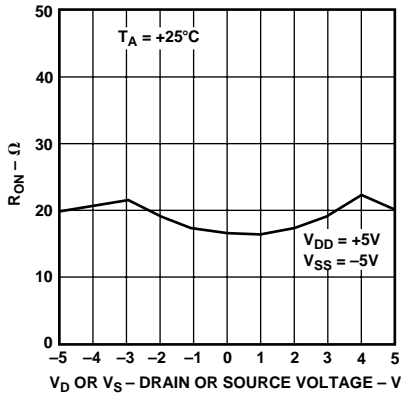

Figure 1. On Resistance as a Function of V_D (V_S) Dual Supplies

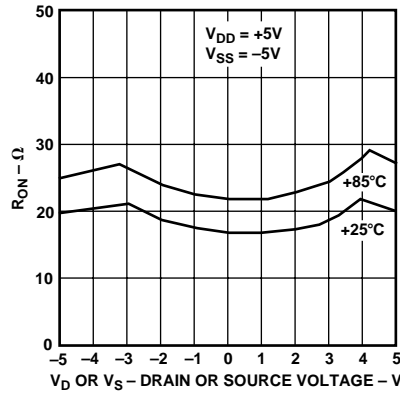

Figure 2. On Resistance as a Function of V_D (V_S) for Different Temperatures

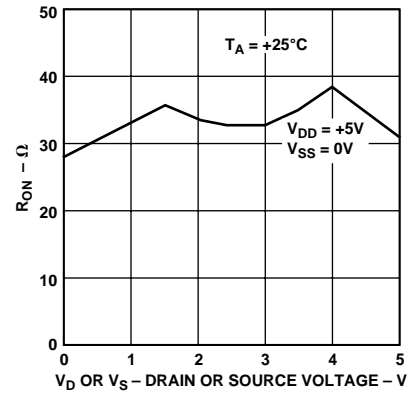

Figure 3. On Resistance as a Function of V_D (V_S) Single Supply

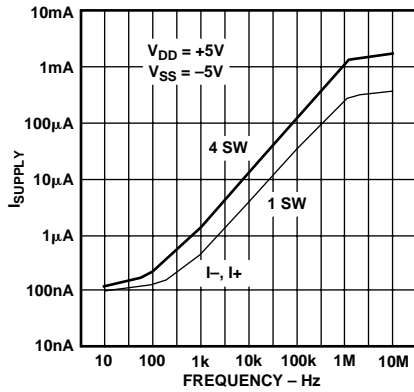

Figure 4. Supply Current vs. Input Switching Frequency

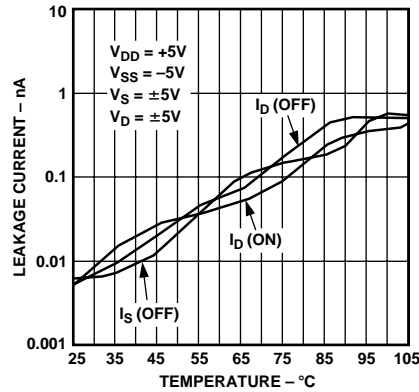

Figure 5. Leakage Currents as a Function of Temperature

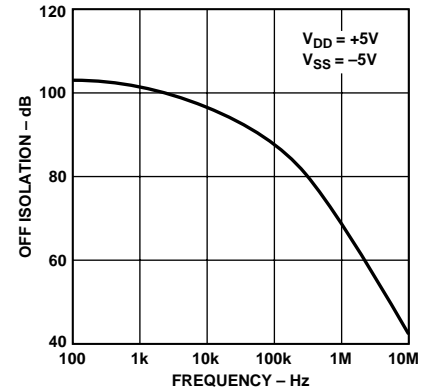

Figure 6. Off Isolation vs. Frequency

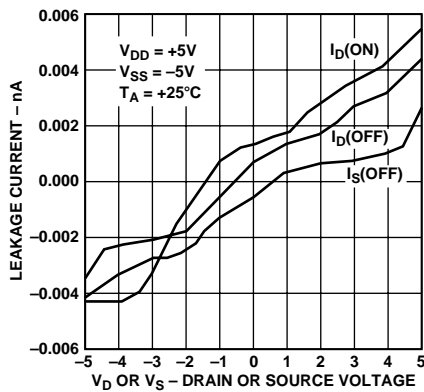

Figure 7. Leakage Currents as a Function of V_D (V_S)

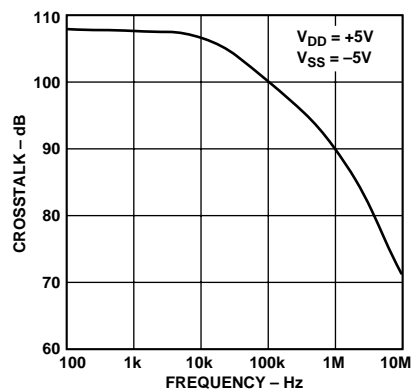
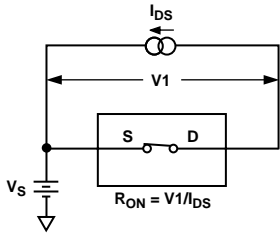
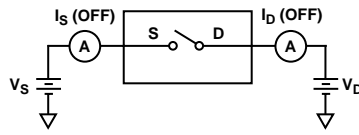

Figure 8. Crosstalk vs. Frequency

Test Circuits



1. On Resistance



2. Off Leakage

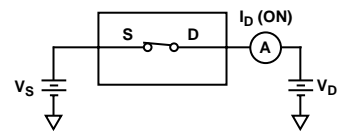

3. On Leakage

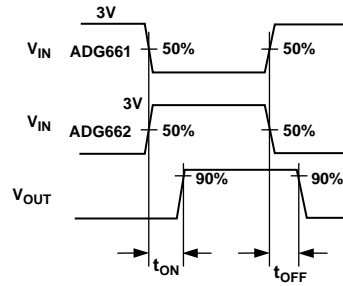
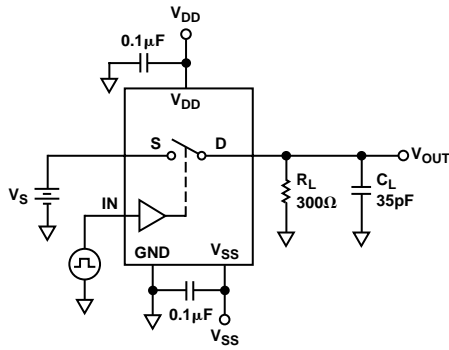

4. Switching Times

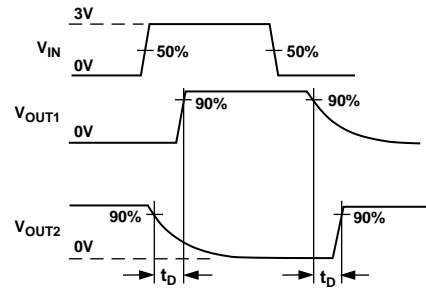
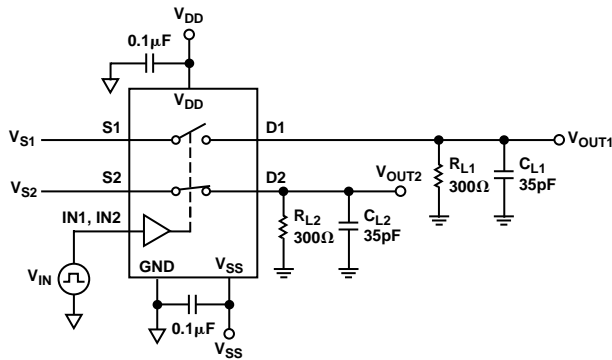

5. Break-Before-Make Time Delay

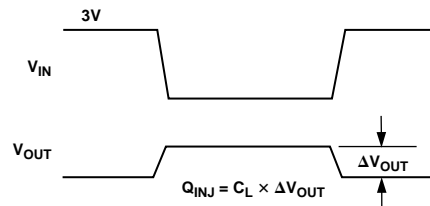
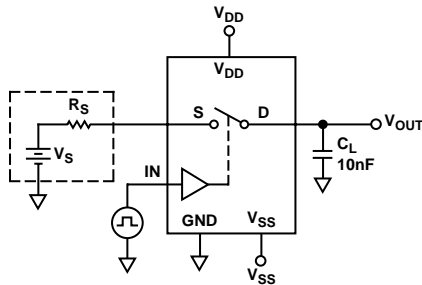

6. Charge Injection

Test Circuits (Continued)

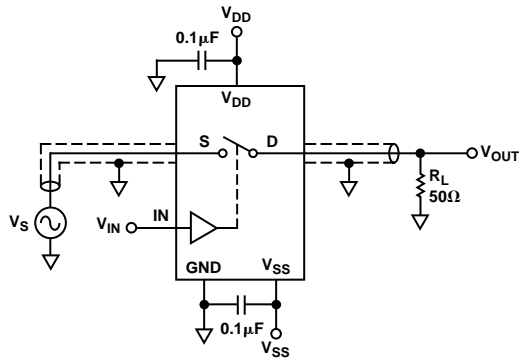

7. Off Isolation

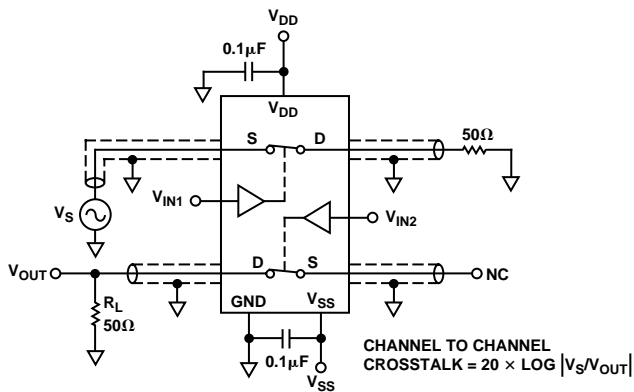

8. Channel-to-Channel Crosstalk

CHANNEL TO CHANNEL CROSSTALK = $20 \times \text{LOG} |V_S/V_{OUT}|$

APPLICATION

Figure 9 illustrates a precise, sample-and-hold circuit. An AD845 is used as the input buffer while the output operational amplifier is an OP07. During the track mode, SW1 is closed and the output V_{OUT} follows the input signal V_{IN} . In the hold mode, SW1 is opened and the signal is held by the hold capacitor C_H .

Due to switch and capacitor leakage, the voltage on the hold capacitor will decrease with time. The ADG661/ADG662/ADG663 minimizes this droop due to its low leakage specifications. The droop rate is further minimized by the use of a poly-styrene hold capacitor. The droop rate for the circuit shown is typically $15 \mu\text{V}/\mu\text{s}$.

A second switch SW2, which operates in parallel with SW1, is included in this circuit to reduce pedestal error. Since both switches will be at the same potential, they will have a differential effect on the op amp OP07 which will minimize charge injection effects. Pedestal error is also reduced by the compensation network R_C and C_C . This compensation network also reduces the hold time glitch while optimizing the acquisition time. Using the illustrated op amps and component values, the pedestal error has a maximum value of 5 mV over the $\pm 3 \text{ V}$ input range. The acquisition time is 2.5 ms while the settling time is $1.85 \mu\text{s}$.

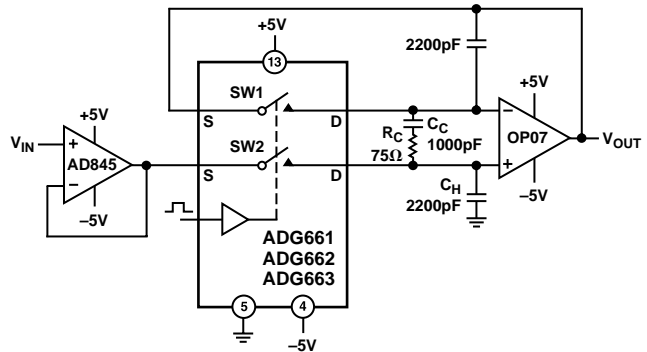
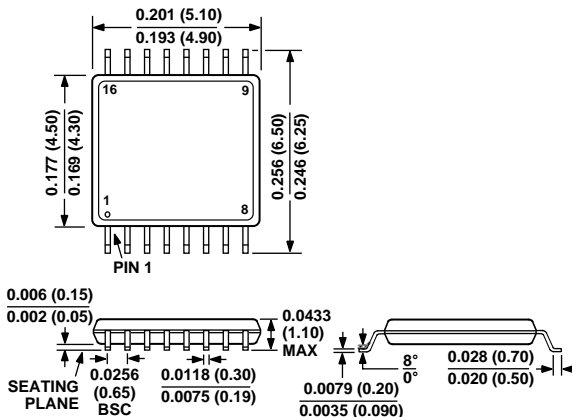

Figure 9. Accurate Sample-and-Hold

OUTLINE DIMENSIONS

Dimensions shown in inches and (mm).

16-Lead TSSOP (RU-16)





LittleDiode supplies new, hard to find or obsolete electronic components and semiconductors all over the world.

With over two million different components listed you are sure to find the part you need.

Feel free to visit us today at our online store:

LittleDiode.com

Looking forward to providing you with the best possible service.