

ADM1232

FEATURES

- Superior Upgrade for MAX1232 and Dallas DS1232
- Low Power Consumption (500 μ A max)
- Adjustable Precision Voltage Monitor with +4.5 V and +4.75 V Options
- Adjustable STROBE Monitor with 150 ms, 600 ms or 1.2 sec Options
- No External Components

APPLICATIONS

- Microprocessor Systems
- Portable Equipment
- Computers
- Controllers
- Intelligent Instruments
- Automotive Systems
- Protection Against Damage Caused by μ P Failure

FUNCTIONAL BLOCK DIAGRAM

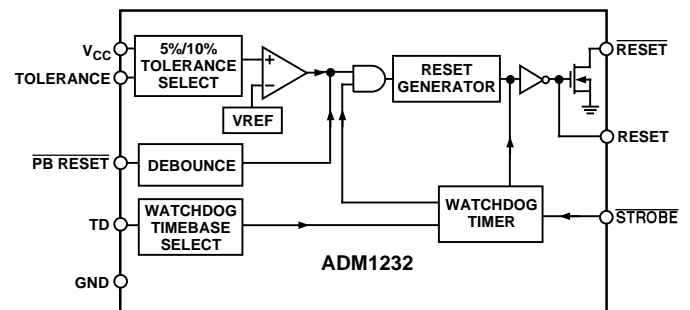

GENERAL DESCRIPTION

The ADM1232 is a superior, pin-compatible upgrade for the MAX1232 and the DS1232LP and DS1232. The Analog Devices ADM1232 is a microprocessor monitoring circuit that can monitor:

1. Microprocessor Supply Voltage.
2. Whether a Microprocessor has locked-up.
3. An External Interrupt.

The ADM1232 is available in four different packages:

1. The ADM1232ARM in an 8-lead microSOIC (RM-8).
2. The ADM1232AN in an 8-lead PDIP (N-8).
3. The ADM1232ARW in a 16-lead wide SOIC (R-16).
4. The ADM1232ARN is an 8-lead narrow SOIC (R-8).

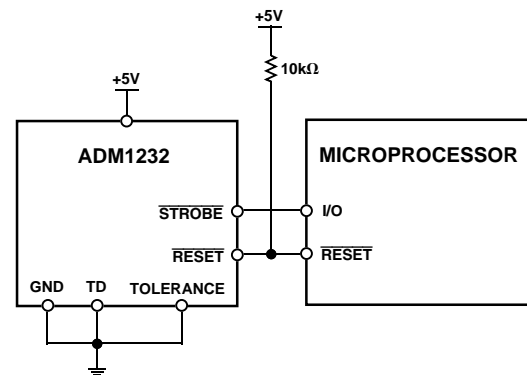

Figure 1. Typical Supply Monitoring Application

REV. B

Information furnished by Analog Devices is believed to be accurate and reliable. However, no responsibility is assumed by Analog Devices for its use, nor for any infringements of patents or other rights of third parties which may result from its use. No license is granted by implication or otherwise under any patent or patent rights of Analog Devices.

ADM1232–SPECIFICATIONS (V_{CC} = Full Operating Range, T_A = T_{MIN} to T_{MAX} unless otherwise noted)

Parameter	Min	Typ	Max	Units	Test Conditions/Comments
TEMPERATURE	-40		+85	°C	T _A = T _{MIN} to T _{MAX}
POWER SUPPLY					
Voltage	4.5	5.0	5.5	V	V _{IL} , V _{IH} = CMOS Levels V _{IL} , V _{IH} = TTL Levels
Current		20	50	μA	
		200	500	μA	
STROBE AND PB RESET INPUTS					
Input High Level	2.0		V _{CC} + 0.3	V	
Input Low Level	-0.3		+0.8	V	
INPUT LEAKAGE CURRENT (STROBE, TOLERANCE)					
TD	-1.0	1.6	+1.0	μA	
OUTPUT CURRENT					
RESET	8	10		mA	When V _{CC} Is at 4.5 V–5.5 V When V _{CC} Is at 4.5 V–5.5 V
RESET, RESET	-8	-12		mA	
OUTPUT VOLTAGE					
RESET/RESET	V _{CC} - 0.5	V _{CC} - 0.1		V	While sourcing less than 500 μA, RESET remains within 0.5 V of V _{CC} on power-down until V _{CC} drops below 2.0 V. While sinking less than 500 μA, RESET remains within 0.5 V of GND on power-down until V _{CC} drops below 2.0 V.
RESET/RESET High Level			0.4	V	
RESET/RESET Low Level	2.4			V	
1 V OPERATION					
RESET Output Voltage		V _{CC} - 0.1		V	While Sourcing Less than 50 μA While Sinking Less than 50 μA
RESET Output Voltage		0.1		V	
V _{CC} TRIP POINT					
5%	4.5	4.62	4.74	V	TOLERANCE = GND
10%	4.25	4.37	4.49	V	TOLERANCE = V _{CC}
CAPACITANCE					
Input (STROBE, TOLERANCE)			5	pF	T _A = +25°C T _A = +25°C
Output (RESET, RESET)			7	pF	
PB RESET					
Time	20			ms	PB RESET Must Be Held Low for a Minimum of 20 ms to Guarantee a Reset
Delay	1	4	20	ms	
RESET ACTIVE TIME	250	610	1000	ms	
STROBE					
Pulse Width	70			ns	TD = 0 V TD = Floating TD = V _{CC}
Timeout Period	62.5	150	250	ms	
	250	600	1000	ms	
	500	1200	2000	ms	
V _{CC}					
Fall Time	10			μs	Guaranteed by Design
Rise Time	0			μs	Guaranteed by Design
V _{CC} FAIL DETECT TO RESET OUTPUT DELAY RESET AND RESET Are Logically Correct					
			50	μs	After V _{CC} Falls Below the Set Tolerance Voltage (Figure 5) After V _{CC} Rises Above the Set Tolerance Voltage
	250	610	1000	ms	

Specifications subject to change without notice.

ABSOLUTE MAXIMUM RATINGS*

(T_A = +25°C unless otherwise noted)

V _{CC}	+5.5 V
Logic Inputs	-0.3 V to V _{CC} + 0.3 V
Storage Temperature Range	-65°C to +150°C
Lead Temperature (Soldering, 10 sec)	+300°C
Vapor Phase (60 sec)	+215°C
Infrared (15 sec)	+220°C

N-8

Power Dissipation	1000 mW
Derate by 13.5 mW/°C above 25°C	
θ _{JA} Thermal Impedance	100°C/W

R-16

Power Dissipation	900 mW
Derate by 12 mW/°C above 25°C	
θ _{JA} Thermal Impedance (Still Air)	73°C/W

RM-8

Power Dissipation	900 mW
Derate by 12 mW/°C above 25°C	
θ _{JA} Thermal Impedance (Still Air)	206°C/W

R-8

Power Dissipation	900 μW
Derate by 12 mW/°C above 25°C	
θ _{JA} Thermal Impedance (Still Air)	153°C/W

*Stresses above those listed under Absolute Maximum Ratings may cause permanent damage to the device. This is a stress rating only; functional operation of the device at these or any other conditions above those listed in the operational sections of this specification is not implied. Exposure to absolute maximum ratings for extended periods of time may affect device reliability.

ORDERING GUIDE

Model	Temperature Range	Package Options*
ADM1232ARM	-40°C to +85°C	RM-8
ADM1232AN	-40°C to +85°C	N-8
ADM1232ARW	-40°C to +85°C	R-16
ADM1232ARN	-40°C to +85°C	R-8

*N= Plastic DIP; R = Small Outline; RM = microSOIC.

CAUTION

ESD (electrostatic discharge) sensitive device. Electrostatic charges as high as 4000 V readily accumulate on the human body and test equipment and can discharge without detection. Although the ADM1232 features proprietary ESD protection circuitry, permanent damage may occur on devices subjected to high energy electrostatic discharges. Therefore, proper ESD precautions are recommended to avoid performance degradation or loss of functionality.



ADM1232

PIN FUNCTION DESCRIPTIONS

Mnemonic	Function
$\overline{\text{PB RESET}}$	Push Button Reset Input. This debounced input will ignore pulses of less than 1 ms and is guaranteed to respond to pulses greater than 20 ms.
TD	Time Delay Set allows the user to select the maximum amount of time the ADM1232 will allow the $\overline{\text{STROBE}}$ input to remain inactive (i.e., $\overline{\text{STROBE}}$ is not receiving any high-to-low transitions), without forcing the ADM1232 to generate a RESET pulse. (See $\overline{\text{STROBE}}$ specifications, Figure 4 and the note on $\overline{\text{STROBE}}$ timeout selection.)
TOLERANCE	Tolerance Input. This input will determine how much the supply voltage will be allowed to decrease (as a percentage tolerance) before a RESET is asserted. Connect to V_{CC} for 10% and GND for 5%.
GND	0 V ground reference for all signals.
RESET	Active high logic output. Will be asserted when: <ol style="list-style-type: none"> V_{CC} decreases below the amount specified by the TOLERANCE input or, $\overline{\text{PB RESET}}$ is forced low or, If there are no high-to-low transitions within the limits set by TD at $\overline{\text{STROBE}}$ or, During power-up.
$\overline{\text{RESET}}$	Inverse of RESET, with an open drain output.
$\overline{\text{STROBE}}$	The $\overline{\text{STROBE}}$ input is used to monitor the activity of a microprocessor. If there are no high-to-low transitions within the time specified by TD, a reset will be asserted.
V_{CC}	Power supply input +5 V.

PIN CONFIGURATIONS

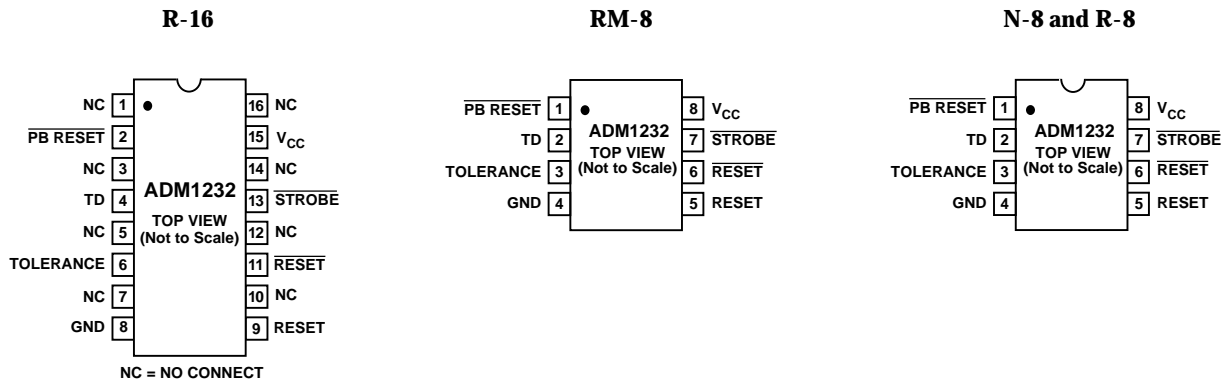

CIRCUIT INFORMATION

PB RESET

The $\overline{\text{PB RESET}}$ input makes it possible to manually reset a system using either a standard push-button switch or a logic low input. An internal debounce circuit provides glitch immunity when used with a switch, reducing the effects of glitches on the line. The debounce circuit is guaranteed to cause the ADM1232 to assert a reset if $\overline{\text{PB RESET}}$ is brought low for more than 20 ms and is guaranteed to ignore low inputs of less than 1 ms.

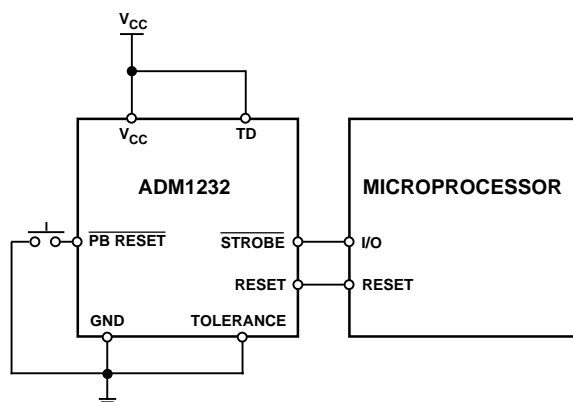

Figure 2. Typical Push Button Reset Application

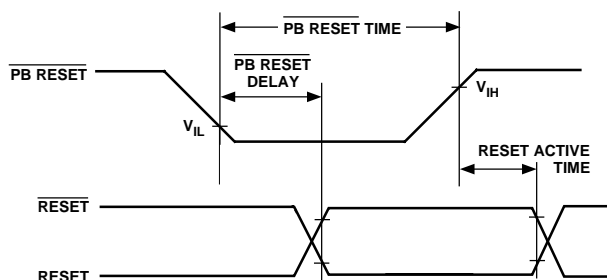

Figure 3. $\overline{\text{PB RESET}}$

STROBE Timeout Selection

TD or time delay set is used to set the Strobe Timeout Period. The Strobe Timeout Period is defined as being the maximum time between high-to-low transitions (Figure 4) that $\overline{\text{STROBE}}$ will accept before a reset will be asserted. The Strobe timeout settings are listed in Table I.

Table I.

Condition	Min	Typ	Max	Units
TD = 0 V	62.5	150	250	ms
TD = Floating	250	600	1000	ms
TD = V_{CC}	500	1200	2000	ms

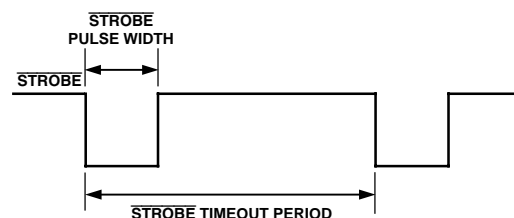

Figure 4. $\overline{\text{STROBE}}$ Parameters

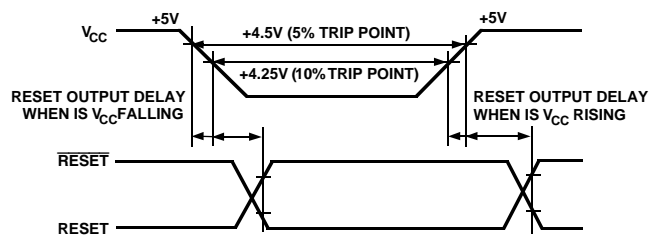

Figure 5. Reset Output Delay

TOLERANCE

The TOLERANCE input is used to determine the level V_{CC} can vary below 5 V without the ADM1232 asserting a reset. Connecting TOLERANCE to ground will select a -5% tolerance level and will cause the ADM1232 to generate a reset if V_{CC} falls below 4.75 V (typical). If TOLERANCE is connected to V_{CC} a -10% tolerance level is selected and will cause the ADM1232 to generate a reset if V_{CC} falls below 4.5 V (typical). Check the parameters for the V_{CC} trip point in the ADM1232 Specifications for more information.

RESET AND $\overline{\text{RESET}}$ OUTPUTS

While RESET is capable of sourcing and sinking current, $\overline{\text{RESET}}$ is an open drain MOSFET which sinks current only. Therefore, it is necessary to pull this output high.

OUTLINE DIMENSIONS
 Dimensions shown in inches and (mm).

16-Lead Wide SOIC (R-16)

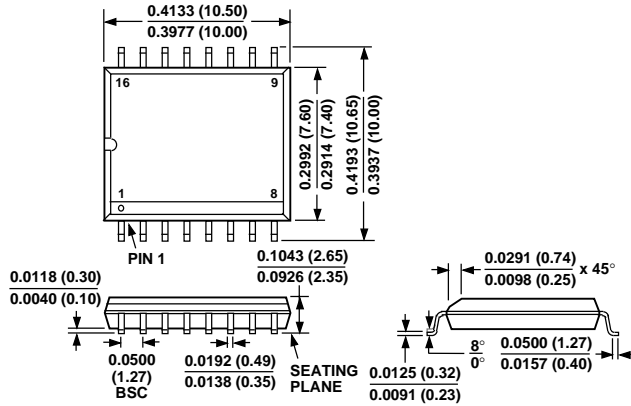

8-Lead PDIP (N-8)

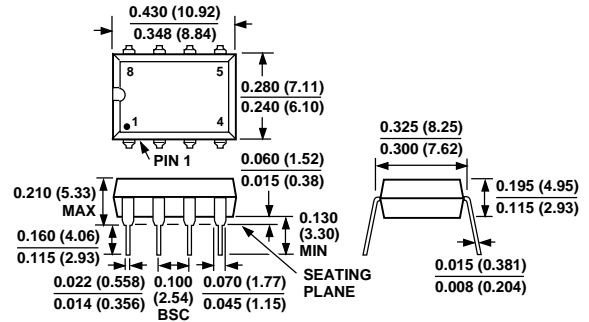

8-Lead microSOIC (RM-8)

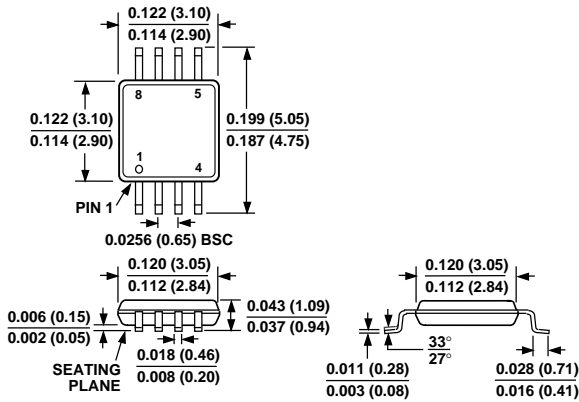

8-Lead Narrow SOIC (R-8)

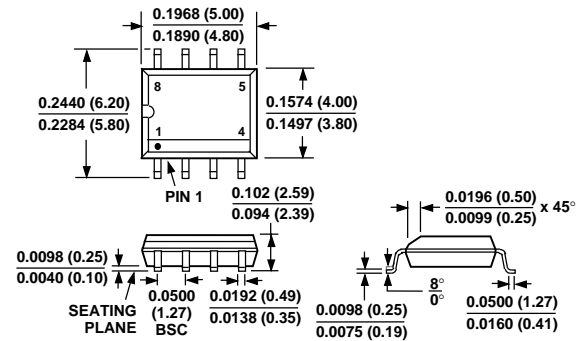



LittleDiode supplies new, hard to find or obsolete electronic components and semiconductors all over the world.

With over two million different components listed you are sure to find the part you need.

Feel free to visit us today at our online store:

LittleDiode.com

Looking forward to providing you with the best possible service.