

ADMC331

TARGET APPLICATIONS

Washing Machines, Refrigerator Compressors, Fans,
Pumps, Industrial Variable Speed Drives

FEATURES

26 MIPS Fixed-Point DSP Core
Single Cycle Instruction Execution (38.5 ns)
ADSP-2100 Family Code Compatible
Independent Computational Units
ALU
Multiplier/Accumulator
Barrel Shifter
Multifunction Instructions
Single Cycle Context Switch
Powerful Program Sequencer
Zero Overhead Looping
Conditional Instruction Execution
Two Independent Data Address Generator
Memory Configuration
2K × 24-Bit Program Memory RAM
2K × 24-Bit Program Memory ROM
1K × 16-Bit Data Memory RAM
Three-Phase 16-Bit PWM Generator
16-Bit Center-Based PWM Generator
Programmable Deadtime and Narrow Pulse Deletion

Edge Resolution to 38.5 ns
198 Hz Minimum Switching Frequency
Double/Single Duty Cycle Update Mode Control
Programmable PWM Pulsewidth
Suitable for AC Induction and Synchronous Motors
Special Signal Generation for Switched Reluctance Motors
Special Crossover Function for Brushless DC Motors
Individual Enable and Disable for all PWM Outputs
High Frequency Chopping Mode for Transformer Coupled Gate Drives
Hardwired Polarity Control
External PWMTRIP Pin
Seven Analog Input Channels
Acquisition Synchronized to PWM Switching Frequency
Conversion Speed Control
24 Bits of Digital I/O Port
Bit Configurable as Input or Output
Change of State Interrupt Support
Two 8-Bit Auxiliary PWM Timers
Synchronized Analog Output
Programmable Frequency
0% to 100% Duty Cycle

(Continued on page 7)

FUNCTIONAL BLOCK DIAGRAM

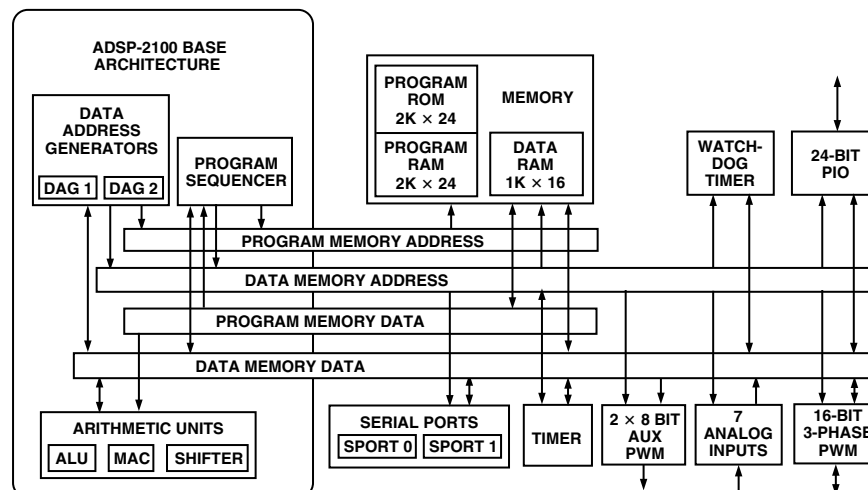

REV. B

Information furnished by Analog Devices is believed to be accurate and reliable. However, no responsibility is assumed by Analog Devices for its use, nor for any infringements of patents or other rights of third parties which may result from its use. No license is granted by implication or otherwise under any patent or patent rights of Analog Devices.

ADMC331—SPECIFICATIONS (V_{DD} = +5 V ± 10%, GND = SGND = 0 V, T_A = -40°C to +85°C, unless otherwise noted)

Parameter	Min	Typ	Max	Units	Conditions/Comments
ANALOG-TO-DIGITAL CONVERTER					
Signal Input	0.3		3.3 ¹	V	Charging Capacitor = 1000 pF 2.5 kHz Sample Frequency
Resolution			12 ²	Bits	No Missing Codes
Converter Linearity		2	12	LSBs	
Zero Offset		5	50	mV	
Channel-to-Channel Comparator Match			22	mV	
Comparator Delay		600		ns	
Current Source	10.16	12.7	15.24	μA	
Current Source Linearity			2	%	
ELECTRICAL CHARACTERISTICS					
V _{IL} Logic Low			0.8	V	
V _{IH} Logic High	2			V	
V _{OL} Low Level Output Voltage			0.4	V	I _{OL} = 2 mA
V _{OL} Low Level Output Voltage (XTAL)			0.5	V	I _{OL} = 2 mA
V _{OH} High Level Output Voltage	4			V	I _{OH} = 0.5 mA
I _{IL} Low Level Input Current	-10			μA	V _{IN} = 0 V
I _{IH} High Level Input Current			10	μA	V _{IN} = V _{DD}
I _{IH} Hi-Level PWMTRIP, PIO0–PIO23 Current			100	μA	@ V _{DD} = max, V _{IN} = V _{DD} max
I _{IH} Hi-Level PWMPOL/PWMSR Current			10	μA	@ V _{DD} = max, V _{IN} = V _{DD} max
I _{IL} Lo-Level PWMTRIP, PIO0–PIO23 Current			10	μA	@ V _{DD} = max, V _{IN} = 0 V
I _{IL} Lo-Level PWMPOL/PWMSR Current			100	μA	@ V _{DD} = max, V _{IN} = 0 V
I _{DD} Supply Current (Dynamic)			120	mA	13 MHz DSP Clock
I _{DD} Supply Current (Idle)			60	mA	13 MHz DSP Clock
REFERENCE VOLTAGE OUTPUT					
Voltage Level	2.2	2.55	2.9	V	100 μA Load
Output Voltage Change T _{MIN} to T _{MAX}		20		mV	
16-BIT PWM TIMER					
Counter Resolution			16	Bits	
Edge Resolution (Single Update Mode)		76.9		ns	13 MHz CLKIN
Edge Resolution (Double Update Mode)		38.5		ns	13 MHz CLKIN
Programmable Deadtime Range	0		78	μs	13 MHz CLKIN
Programmable Deadtime Increments		76.9		ns	13 MHz CLKIN
Programmable Pulse Deletion Range	0		78	μs	13 MHz CLKIN
Programmable Pulse Deletion Increments		76.9		ns	13 MHz CLKIN
PWM Frequency Range	0.198			kHz	13 MHz CLKIN
PWMSYNC Pulsewidth (T _{CRST})	0.077		9.8	μs	13 MHz CLKIN
Gate Drive Chop Frequency Range	0.02		6.5	MHz	13 MHz CLKIN
AUXILIARY PWM TIMERS					
Resolution		8		Bits	
PWM Frequency	0.051		6.5	MHz	13 MHz CLKIN

NOTES

¹Signal input max V = 3.5 V if V_{DD} = 5 V ± 5%.

²Resolution varies with PWM switching frequency (13 MHz Clock in Double Update mode), 50.7 kHz = 9 bits, 6.3 kHz = 12 bits.

Specifications subject to change without notice.

TIMING PARAMETERS

Parameter	Min	Max	Unit
Clock Signals			
<p>t_{CK} is defined as $0.5 t_{CKI}$. The ADMC331 uses an input clock with a frequency equal to half the instruction rate; a 13 MHz input clock (which is equivalent to 76.9 ns) yields a 38.5 ns processor cycle (equivalent to 26 MHz). t_{CK} values within the range of $0.5 t_{CKI}$ period should be substituted for all relevant timing parameters to obtain specification value.</p> <p>Example: $t_{CKH} = 0.5 t_{CK} - 10 \text{ ns} = 0.5 (38.5 \text{ ns}) - 10 \text{ ns} = 9.25 \text{ ns}$.</p> <p><i>Timing Requirements:</i></p> <p>t_{CKI} CLKIN Period 76.9 150 ns t_{CKIL} CLKIN Width Low 20 ns t_{CKIH} CLKIN Width High 20 ns</p> <p><i>Switching Characteristics:</i></p> <p>t_{CKL} CLKOUT Width Low $0.5 t_{CK} - 10$ ns t_{CKH} CLKOUT Width High $0.5 t_{CK} - 10$ ns t_{CKOH} CLKIN High to CLKOUT High 0 20 ns</p>			
Control Signals			
<i>Timing Requirement:</i>			
t_{RSP} RESET Width Low	$5 t_{CK}^1$		ns
PWM Shutdown Signals			
<i>Timing Requirement:</i>			
t_{PWTMPW} $\overline{\text{PWMTRIP}}$ Width Low	$2 t_{CK}$		ns

NOTE

¹Applies after power-up sequence is complete. Internal phase lock loop requires no more than 2000 CLKIN cycles assuming stable CLKIN (not including crystal oscillator start-up time).

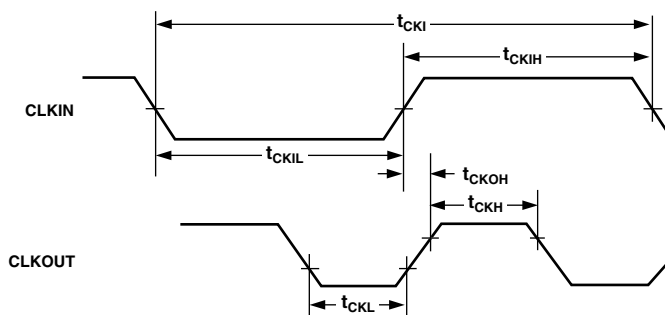

Figure 1. Clock Signals

ADMC331

Parameter		Min	Max	Unit
Serial Ports				
<i>Timing Requirements:</i>				
t_{SCK}	SCLK Period	100		ns
t_{SCS}	DR/TFS/RFS Setup before SCLK Low	15		ns
t_{SCH}	DR/TFS/RFS Hold after SCLK Low	20		ns
t_{SCP}	SCLK _{IN} Width	40		ns
<i>Switching Characteristics:</i>				
t_{CC}	CLKOUT High to SCLK _{OUT}	$0.25 t_{CK}$	$0.25 t_{CK} + 20$	ns
t_{SCDE}	SCLK High to DT Enable	0		ns
t_{SCDV}	SCLK High to DT Valid		30	ns
t_{RH}	TFS/RFS _{OUT} Hold after SCLK High	0		ns
t_{RD}	TFS/RFS _{OUT} Delay from SCLK High		30	ns
t_{SCDH}	DT Hold after SCLK High	0		ns
t_{SCDD}	SCLK High to DT Disable		30	ns
t_{TDE}	TFS (Alt) to DT Enable	0		ns
t_{TDV}	TFS (Alt) to DT Valid		25	ns
t_{RDV}	RFS (Multichannel, Frame Delay Zero) to DT Valid		30	ns

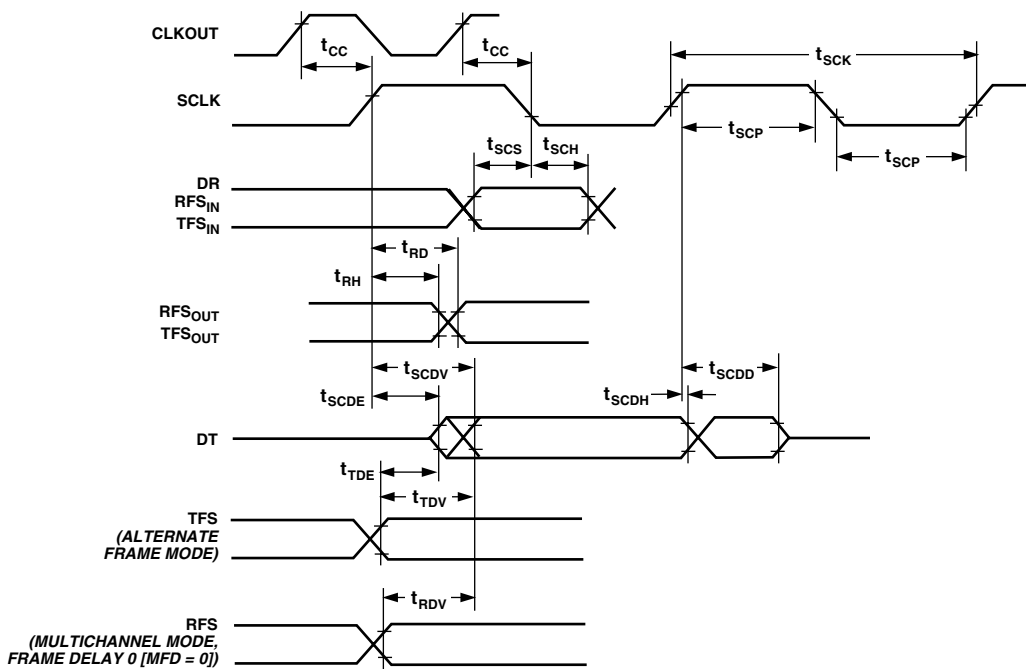

Figure 2. Serial Ports

ABSOLUTE MAXIMUM RATINGS*

Supply Voltage (V_{DD}) -0.3 V to +7.0 V
 Supply Voltage (AV_{DD}) -0.3 V to +7.0 V
 Input Voltage -0.3 V to $V_{DD} + 0.3$ V
 Output Voltage Swing -0.3 V to $V_{DD} + 0.3$ V
 Operating Temperature Range (Ambient) ... -40°C to +85°C
 Storage Temperature Range -65°C to +150°C
 Lead Temperature (5 sec) +280°C

*Stresses greater than those listed above may cause permanent damage to the device. These are stress ratings only; functional operation of the device at these or any other conditions greater than those indicated in the operational sections of this specification is not implied. Exposure to absolute maximum rating conditions for extended periods may affect device reliability.

ORDERING GUIDE

Model	Temperature Range	Instruction Rate	Package Description	Package Option
ADMC331BST ADMC331-ADVEVALKIT ADMC331-PB	-40°C to +85°C	26 MHz	80-Lead Plastic Thin Quad Flatpack (TQFP) Development Tool Kit Evaluation/Processor Board	ST-80

CAUTION

ESD (electrostatic discharge) sensitive device. Electrostatic charges as high as 4000 V readily accumulate on the human body and test equipment and can discharge without detection. Although the ADMC331 features proprietary ESD protection circuitry, permanent damage may occur on devices subjected to high-energy electrostatic discharges. Therefore, proper ESD precautions are recommended to avoid performance degradation or loss of functionality.



ADMC331

PIN FUNCTION DESCRIPTIONS

Pin No.	Pin Type	Pin Name	Pin No.	Pin Type	Pin Name	Pin No.	Pin Type	Pin Name	Pin No.	Pin Type	Pin Name
1	O/P	VREF	21	SUP	V _{DD}	41	GND	GND	61	BIDIR	TFS0
2	SUP	AV _{DD}	22	GND	GND	42	GND	GND	62	BIDIR	RFS0
3	GND	GND	23	BIDIR	PIO12	43	O/P	XTAL	63	I/P	DR0
4	BIDIR	PIO9	24	BIDIR	PIO13	44	I/P	CLKIN	64	BIDIR	SCLK0
5	BIDIR	PIO8	25	O/P	PWMSYNC	45	I/P	PWMPOL	65	BIDIR	PIO21
6	BIDIR	PIO7	26	O/P	CL	46	I/P	RESET	66	BIDIR	PIO22
7	BIDIR	PIO6	27	O/P	CH	47	GND	GND	67	BIDIR	PIO23
8	BIDIR	PIO5	28	O/P	BL	48	SUP	V _{DD}	68	SUP	V _{DD}
9	BIDIR	PIO4	29	O/P	BH	49	BIDIR	PIO19	69	GND	GND
10	BIDIR	PIO3	30	O/P	AL	50	BIDIR	PIO20	70	GND	AGND
11	BIDIR	PIO2	31	O/P	AH	51	O/P	CLKOUT	71	I/P	CAPIN
12	BIDIR	PIO1	32	BIDIR	PIO14	52	GND	GND	72	O/P	ICONST
13	BIDIR	PIO0	33	BIDIR	PIO15	53	O/P	DT1	73	GND	SGND
14	O/P	AUX1	34	BIDIR	PIO16	54	BIDIR	TFS1	74	I/P	V1
15	O/P	AUX0	35	SUP	V _{DD}	55	BIDIR	RFS1/SROM	75	I/P	V2
16	BIDIR	PIO10	36	GND	GND	56	I/P	DR1A	76	I/P	V3
17	BIDIR	PIO11	37	BIDIR	PIO17	57	I/P	DR1B	77	I/P	VAUX0
18	SUP	V _{DD}	38	GND	GND	58	BIDIR	SCLK1	78	I/P	VAUX1
19	I/P	PWMTRIP	39	BIDIR	PIO18	59	O/P	DT0	79	I/P	VAUX2
20	GND	GND	40	GND	GND	60	I/P	PWMSR	80	I/P	VAUX3

PIN CONFIGURATION 80-Lead Plastic Thin Quad Flatpack (TQFP) (ST-80)

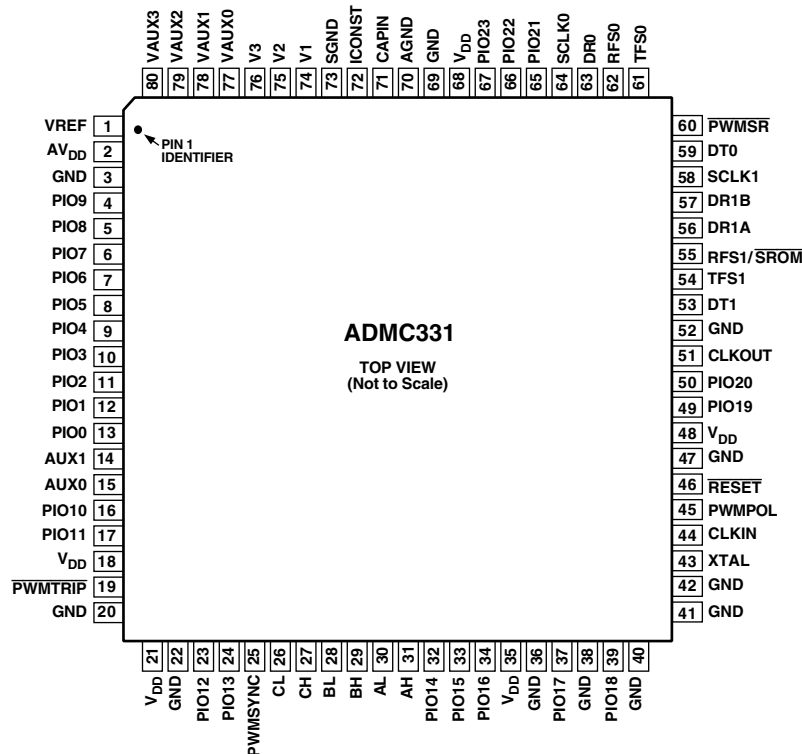

(Continued from page 1)

- Two Programmable Operational Modes**
 - Independent Mode**
 - Offset Mode**
- 16-Bit Watchdog Timer**
- Programmable 16-Bit Internal Timer with Prescaler**
- Two Double Buffered Synchronous Serial Ports**
 - Four Boot Load Protocols via SPORT1**
 - E²PROM/SROM Booting**
 - UART Booting (SCI Compatible) with Autobaud Feature**
 - Synchronous Master Booting with Autobaud Feature**
 - Synchronous Slave Booting with Autobaud Feature**
 - Debugger Interface via SPORT1 with Autobaud (UART and Synchronous Supported)**
- ROM Utilities**
 - Full Debugger for Program Development**
 - Preprogrammed Math Functions**
 - Preprogrammed Motor Control Functions—Vector Transformations**
- 80-Lead TQFP Package**
- Industrial Temperature Range -40°C to +85°C**

GENERAL DESCRIPTION

The ADMC331 is a low cost, single-chip DSP-based controller, suitable for ac induction motors, permanent magnet synchronous motors, brushless dc motors, and switched reluctance motors. The ADMC331 integrates a 26 MIPS, fixed-point DSP core with a complete set of motor control peripherals that permits fast, efficient development of motor controllers.

The DSP core of the ADMC331 is the ADSP-2171, which is completely code compatible with the ADSP-2100 DSP family and combines three computational units, data address generators and a program sequencer. The computational units comprise an ALU, a multiplier/accumulator (MAC) and a barrel shifter. The ADSP-2171 adds new instructions for bit manipulation, multiplication (X squared), biased rounding and global interrupt masking. In addition, two flexible, double-buffered, bidirectional, synchronous serial ports are included in the ADMC331.

The ADMC331 provides 2K × 24-bit program memory RAM, 2K × 24-bit program memory ROM and 1K × 16-bit data memory RAM. The program and data memory RAM can be boot loaded through the serial port from a Serial ROM (SROM), E²PROM, asynchronous (UART) connection or synchronous connection. The program memory ROM includes a monitor that adds software debugging features through the serial port. In addition, a number of preprogrammed mathematical and motor control functions are included in the program memory ROM.

The motor control peripherals of the ADMC331 include a 16-bit center-based PWM generation unit that can be used to produce high accuracy PWM signals with minimal processor overhead and seven analog input channels. The device also contains two auxiliary 8-bit PWM channels, a 16-bit watchdog timer and expanded capability through the serial ports and 24-bit digital I/O ports.

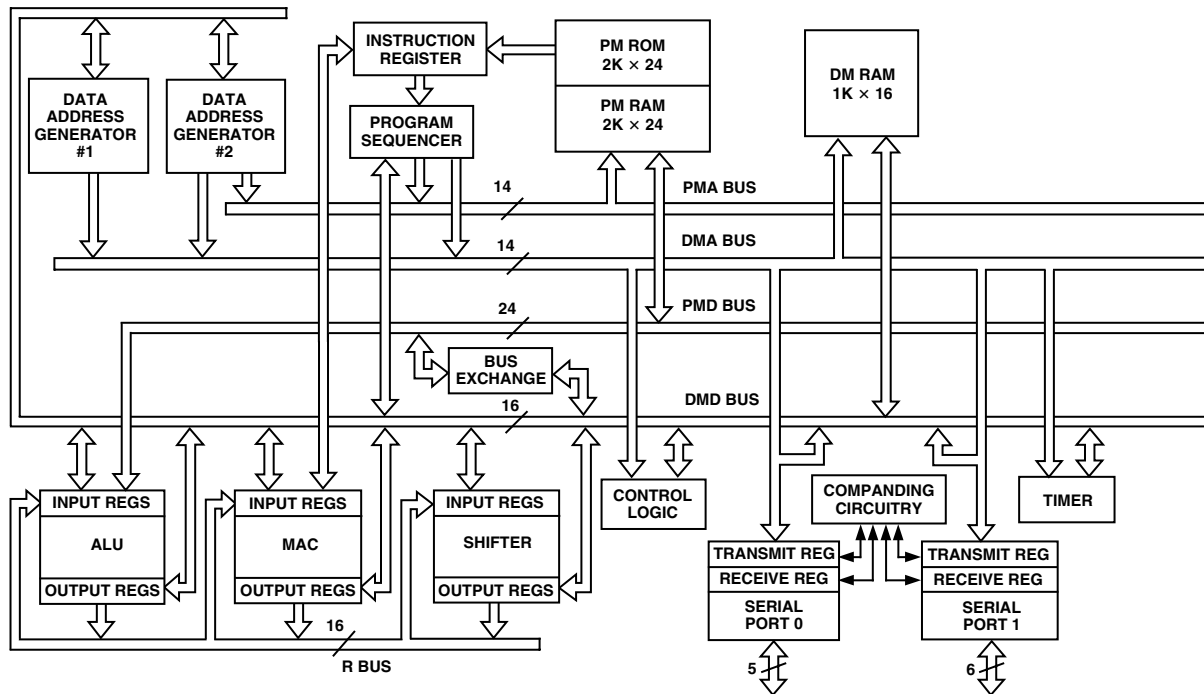

Figure 3. DSP Core Block Diagram

DSP CORE ARCHITECTURE OVERVIEW

Figure 3 is an overall block diagram of the DSP core of the ADCM331, which is based on the fixed-point ADSP-2171. The flexible architecture and comprehensive instruction set of the ADSP-2171 allows the processor to perform multiple operations in parallel. In one processor cycle (38.5 ns with a 13 MHz CLKIN) the DSP core can:

- Generate the next program address.
- Fetch the next instruction.
- Perform one or two data moves.
- Update one or two data address pointers.
- Perform a computational operation.

This all takes place while the processor continues to:

- Receive and transmit through the serial ports.
- Decrement the interval timer.
- Generate three-phase PWM waveforms for a power inverter.
- Generate two signals using the 8-bit auxiliary PWM timers.
- Acquire four analog signals.
- Decrement the watchdog timer.

The processor contains three independent computational units: the arithmetic and logic unit (ALU), the multiplier/accumulator (MAC) and the shifter. The computational units process 16-bit data directly and have provisions to support multiprecision computations. The ALU performs a standard set of arithmetic and logic operations; division primitives are also supported. The MAC performs single-cycle multiply, multiply/add, multiply/subtract operations with 40 bits of accumulation. The shifter performs logical and arithmetic shifts, normalization, denormalization and derive exponent operations. The shifter can be used to efficiently implement numeric format control including floating-point representations.

The internal result (R) bus directly connects the computational units so that the output of any unit may be the input of any unit on the next cycle.

A powerful program sequencer and two dedicated data address generators ensure efficient delivery of operands to these computational units. The sequencer supports conditional jumps and subroutine calls and returns in a single cycle. With internal loop counters and loop stacks, the ADCM331 executes looped code with zero overhead; no explicit jump instructions are required to maintain the loop.

Two data address generators (DAGs) provide addresses for simultaneous dual operand fetches from data memory and program memory. Each DAG maintains and updates four address pointers (I registers). Whenever the pointer is used to access data (indirect addressing), it is post-modified by the value in one of four modify (M registers). A length value may be associated with each pointer (L registers) to implement automatic modulo addressing for circular buffers. The circular buffering feature is also used by the serial ports for automatic data transfers to and from on-chip memory. DAG1 generates only data memory address but provides an optional bit-reversal capability. DAG2 may generate either program or data memory addresses, but has no bit-reversal capability.

Efficient data transfer is achieved with the use of five internal buses:

- Program Memory Address (PMA) Bus
- Program Memory Data (PMD) Bus
- Data Memory Address (DMA) Bus
- Data Memory Data (DMD) Bus
- Result (R) Bus

Program memory can store both instructions and data, permitting the ADMC331 to fetch two operands in a single cycle—one from program memory and one from data memory. The ADMC331 can fetch an operand from on-chip program memory and the next instruction in the same cycle.

The ADMC331 writes data from its 16-bit registers to the 24-bit program memory using the PX register to provide the lower eight bits. When it reads data (not instructions) from 24-bit program memory to a 16-bit data register, the lower eight bits are placed in the PX register.

The ADMC331 can respond to a number of distinct DSP core and peripheral interrupts. The DSP core interrupts include serial port receive and transmit interrupts, timer interrupts, software interrupts and external interrupts. The motor control peripherals also produce interrupts to the DSP core.

The two serial ports (SPORTs) provide a complete synchronous serial interface with optional companding in hardware and a wide variety of framed and unframed data transmit and receive modes of operation. Each SPORT can generate an internal programmable serial clock or accept an external serial clock. Boot loading of both the program and data memory RAM of the ADMC331 is through the serial port SPORT1.

A programmable interval counter is also included in the DSP core and can be used to generate periodic interrupts. A 16-bit count register (TCOUNT) is decremented every n processor cycle, where $n-1$ is a scaling value stored in the 8-bit TSCALE register. When the value of the counter reaches zero, an interrupt is generated and the count register is reloaded from a 16-bit period register (TPERIOD).

The ADMC331 instruction set provides flexible data moves and multifunction (one or two data moves with a computation) instructions. Each instruction is executed in a single 38.5 ns processor cycle (for a 13 MHz CLKIN). The ADMC331 assembly language uses an algebraic syntax for ease of coding and readability. A comprehensive set of development tools support program development. For further information on the DSP core, refer to the *ADSP-2100 Family User's Manual, Third Edition*, with particular reference to the ADSP-2171.

Serial Ports

The ADMC331 incorporates two complete synchronous serial ports (SPORT0 and SPORT1) for serial communication and multiprocessor communication. Following is a brief list of capabilities of the ADMC331 SPORTs. Refer to the *ADSP-2100 Family User's Manual, Third Edition*, for further details.

- SPORTs are bidirectional and have a separate, double-buffered transmit and receive section.
- SPORTs can use an external serial clock or generate their own serial clock internally.

- SPORTs have independent framing for the receive and transmit sections. Sections run in a frameless mode or with frame synchronization signals internally or externally generated. Frame synchronization signals are active high or inverted, with either of two pulsewidths and timings.
- SPORTs support serial data word lengths from 3 bits to 16 bits and provide optional A-law and μ -law companding according to ITU (formerly CCITT) recommendation G.711.
- SPORT receive and transmit sections can generate unique interrupts on completing a data word transfer.
- SPORTs can receive and transmit an entire circular buffer of data with only one overhead cycle per data word. An interrupt is generated after a data buffer transfer.
- SPORT0 has a multichannel interface to selectively receive and transmit a 24-word or 32-word, time-division multiplexed, serial bitstream.
- SPORT1 can be configured to have two external interrupts ($\overline{\text{IRQ0}}$ and $\overline{\text{IRQ1}}$), and the Flag In and Flag Out signals. The internally generated serial clock may still be used in this configuration.
- SPORT1 is the default input for program and data memory boot loading. The RFS1 pin can be configured internal to the ADMC331 as an SROM/E²PROM reset signal.
- SPORT1 has two data receive pins (DR1A and DR1B). The DR1A pin is intended for synchronous boot loading from the external SROM/E²PROM. The DR1B pin can be used as the data receive pin for boot loading from an external asynchronous (UART) connection (SCI compatible), an external synchronous connection as the data receive pin for an external device communicating over the debugger interface, or as the data receive pin for a general purpose SPORT after booting. These two pins are internally multiplexed onto the one DR1 port of the SPORT. The particular data receive pin selected is determined by a bit in the MODECTRL register.

ADMC331

PIN FUNCTION DESCRIPTION

The ADMC331 is available in an 80-lead TQFP package. Table I contains the pin descriptions.

Table I. Pin List

Pin Group Name	# of Pins	Input/Output	Function
RESET	1	I/P	Processor Reset Input.
SPORT0	5	I/P, O/P	Serial Port 0 Pins (TFS0, RFS0, DT0, DR0, SCLK0).
SPORT1	6	I/P, O/P	Serial Port 1 Pins (TFS1, RFS1, DT1, DR1A, DR1B, SCLK1).
CLKOUT	1	O/P	Processor Clock Output.
CLKIN, XTAL	2	I/P, O/P	External Clock or Quartz Crystal Connection Point.
PIO0–PIO23	24	I/P, O/P	Digital I/O Port Pins.
AUX0–AUX1	2	O/P	Auxiliary PWM Outputs.
AH–CL	6	O/P	PWM Outputs.
PWMTRIP	1	I/P	PWM Trip Signal.
PWMPOL	1	I/P	PWM Polarity Pin.
PWMSYNC	1	O/P	PWM Synchronization Pin.
PWMSR	1	I/P	Switch Reluctance Mode Pin.
V1–V3,	3	I/P	Analog Inputs.
VAUX0–VAUX3	4	I/P	Auxiliary Analog Input
CAPIN	1	I/P	ADC Capacitor Input.
ICONST	1	O/P	ADC Constant Current Source.
VREF	1	O/P	Voltage Reference Output.
AV _{DD}	1		Analog Power Supply.
AGND	1		Analog Ground.
SGND	1		Analog Signal Ground
V _{DD}	5		Digital Power Supply.
GND	11		Digital Ground.

INTERRUPT OVERVIEW

The ADMC331 can respond to 34 different interrupt sources with minimal overhead, 8 of which are internal DSP core interrupts and 26 interrupts from the motor control peripherals. The 8 DSP core interrupts are SPORT0 receive and transmit, SPORT1 receive (or $\overline{IRQ0}$) and transmit (or $\overline{IRQ1}$), the internal timer and two software interrupts. The motor control peripheral interrupts are the 24 peripheral I/Os and two from the PWM (PWMSYNC pulse and $\overline{PWMTRIP}$). All motor control interrupts are multiplexed into the DSP core through the peripheral $\overline{IRQ2}$ interrupt. The interrupts are internally prioritized and individually maskable. A detailed description of the entire interrupt system of the ADMC331 is given later, following a more detailed description of each peripheral block.

Memory Map

The ADMC331 has two distinct memory types: program memory and data memory. In general, program memory contains user code and coefficients, while the data memory is used to store variables and data during program execution. Both program memory RAM and ROM are provided on the ADMC331. Program memory RAM is arranged as one contiguous 2K × 24-bit block, starting at address 0x0000. Program memory ROM is located at address 0x0800. Data memory is arranged as a 1K × 16-bit block starting at address 0x3800. The motor control peripherals are memory mapped into a region of the data memory space starting at 0x2000. The complete program and data memory maps are given in Tables II and III, respectively.

Table II. Program Memory Map

Address Range	Memory Type	Function
0x0000–0x002F	RAM	Interrupt Vector Table
0x0030–0x071F	RAM	User Program Space
0x0720–0x07EC	RAM	Reserved by Debugger
0x07ED–0x07FF	RAM	Reserved by Monitor
0x0800–0x0DEC	ROM	ROM Monitor
0x0DED–0x0FEA	ROM	ROM Math and Motor Control Utilities
0x0FEB–0x0FFF	ROM	Reserved

Table III. Data Memory Map

Address Range	Memory Type	Function
0x0000–0x1FFF		Reserved
0x2000–0x20FF		Memory Mapped Registers
0x2100–0x37FF		Reserved
0x3800–0x3B5F	RAM	User Data Space
0x3B60–0x3BFF	RAM	Reserved by Monitor
0x3C00–0x3FFF		Memory Mapped Registers

ROM Code

The 2K × 24-bit block of program memory ROM starting at address 0x0800 contains a monitor function that is used to download and execute user programs via the serial port. In addition, the monitor function supports an interactive mode in which commands are received and processed from a host. An example of such a host is the Windows®-based Motion Control Debugger, which is part of the software development system for the ADMC331. In the interactive mode, the host can access both the internal DSP and peripheral motor control registers of the ADMC331, read and write to both program and data memory, implement breakpoints and perform single-step and run/halt operation as part of the program debugging cycle.

In addition to the monitor function, the program memory ROM contains a number of useful mathematical and motor control utilities that can be called as subroutines from the user code. A complete list of these ROM functions is given in Table IV. The start address of the function in the program memory ROM is also given. Refer to the *ADMC331 DSP Motor Controller Developer's Reference Manual* for more details of the ROM functions.

Table IV. ROM Utilities

Utility	Address	Function
PER_RST	0x07F1	Reset Peripherals.
UMASK	0x0DED	Limits Unsigned Value to Given Range.
PUT_VECTOR	0x0DF4	Facilitates User Setup of Vector Table.
SMASK	0x0E06	Limits Signed Value to Given Range.
ADMC_COS	0x0E26	Cosine Function.
ADMC_SIN	0x0E2D	Sine Function.
ARCTAN	0x0E43	Arctangent Function.
RECIPROCAL	0x0E65	Reciprocal (1/x) Function.
SQRT	0x0E7B	Square Root Function.
LN	0x0EB5	Natural Logarithm Function.
LOG	0x0EB8	Logarithm (Base 10) Function.
FLTONE	0x0ED4	Fixed Pt. to Float Conversion.
FIXONE	0x0ED9	Float to Fixed Pt. Conversion.
FPA	0x0EDD	Floating Pt. Addition.
FPS	0x0EEC	Floating Pt. Subtraction.
FPM	0x0EFC	Floating Pt. Multiplication.
FPD	0x0F05	Floating Pt. Division.
FPMACC	0x0F26	Floating Pt. Multiply/Accumulate.
PARK	0x0F48	Forward/Reverse Park Transformation.
REV_CLARK	0x0F5C	Reverse Clark Transformation.
FOR_CLARK	0x0F72	Forward Clark Transformation.
COS64	0x0F80	64 Pt. COS Table.
ONE_BY_X	0x0FC0	16 Pt. 1/x Table.
SDIVQINT	0x0FD0	Unsigned Single Precision Division (Integer).
SDIVQ	0x0FD9	Unsigned Single Precision Division (Fractional).

SYSTEM INTERFACE

Figure 4 shows a basic system configuration for the ADCM331, with an external crystal and serial E²PROM for boot loading of program and data memory RAM.

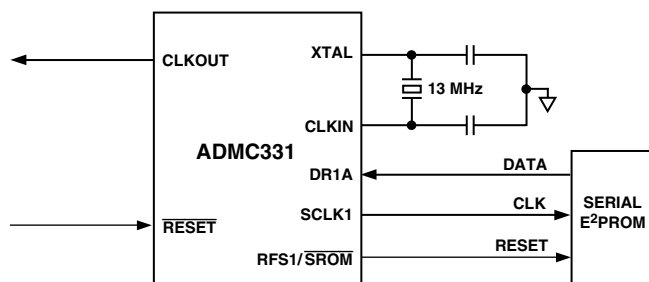

Figure 4. Basic System Configuration

Clock Signals

The ADCM331 can be clocked by either a crystal or a TTL-compatible clock signal. The CLKIN input cannot be halted, changed during operation nor operated below the specified minimum frequency during normal operation. If an external clock is used, it should be a TTL-compatible signal running at half the instruction rate. The signal is connected to the CLKIN pin of the ADCM331. In this mode, with an external clock signal, the XTAL pin must be left unconnected. The ADCM331 uses an input clock with a frequency equal to half the instruction rate; a 13 MHz input clock yields a 38.5 ns processor cycle (which is equivalent to 26 MHz). Normally, instructions are executed in a single processor cycle. All device timing is relative to the internal instruction rate, which is indicated by the CLKOUT signal.

Because the ADCM331 includes an on-chip oscillator feedback circuit, an external crystal may be used instead of a clock source, as shown in Figure 4. The crystal should be connected across the CLKIN and XTAL pins, with two capacitors as shown in Figure 4. A parallel-resonant, fundamental frequency, microprocessor-grade crystal should be used. A clock output signal (CLKOUT) is generated by the processor at the processor's cycle rate of twice the input frequency. This output can be enabled and disabled by the CLKODIS bit of the SPORT0 Autobuffer Control Register, DM[0x3FF3]. However, extreme care must be exercised when using this bit since disabling CLKOUT effectively disables all motor control peripherals, except the watchdog timer.

Reset

The **RESET** signal initiates a master reset of the ADCM331. The **RESET** signal must be asserted during the power-up sequence to assure proper initialization. **RESET** during initial power-up must be held long enough to allow the internal clock to stabilize. If **RESET** is activated any time after power-up, the clock continues to run and does not require stabilization time.

The power-up sequence is defined as the total time required for the crystal oscillator circuit to stabilize after a valid V_{DD} is applied to the processor, and for the internal phase-locked loop (PLL) to lock onto the specific crystal frequency. A minimum of 2000 CLKIN cycles ensures that the PLL has locked, but does not include the crystal oscillator start-up time. During this power-up sequence, the **RESET** signal should be held low. On any subsequent resets, the **RESET** signal must meet the minimum pulsewidth specification, t_{RSP}.

If an RC circuit is used to generate the **RESET** signal, the use of an external Schmitt trigger is recommended.

The master reset sets all internal stack pointers to the empty stack condition, masks all interrupts, initializes DSP core registers and performs a full reset of all of the motor control peripherals. When the **RESET** line is released, the first instruction is fetched from internal program memory ROM at location 0x0800. The internal monitor code at this location then commences the boot-loading sequence over the serial port, SPORT1. A software controlled full peripheral reset is achieved by toggling the DSP FL2 flag from 1 to 0 to 1 again.

ADMC331

Boot Loading

On power-up or reset, the ADMC331 is configured so that execution begins at the internal PM ROM at address 0x0800. This starts execution of the internal monitor function that first performs some initialization functions and copies a default interrupt vector table to addresses 0x0000–0x002F of program memory RAM. The monitor next attempts to boot load from an external SRAM or E²PROM on SPORT1 using the three wire connection of Figure 4. The monitor program first toggles the RFS1/SRAM pin of the ADMC331 to reset the serial memory device. If an SRAM or E²PROM is connected to SPORT1, data is clocked into the ADMC331 at a rate CLKOUT/20. Both program and data memory RAM can be loaded from the SRAM or E²PROM. After the boot load is complete, program execution begins at address 0x0030. This is where the first instruction of the user code should be placed.

If boot loading from an E²PROM is unsuccessful, the monitor code reconfigures SPORT1 as a UART and attempts to receive commands from an external device on this serial port. The monitor then waits for a byte to be received over SPORT1, locks onto the baud rate of the external device (autobaud feature) and takes in a header word that tells it with what type of device it is communicating. There are six alternatives:

- A UART boot loader such as a Motorola 68HC11SCI port.
- A synchronous slave boot loader (the clock is external).
- A synchronous master boot loader (the ADMC331 provides the clock).
- A UART debugger interface.
- A synchronous master debugger interface.
- A synchronous slave debugger interface.

With the debugger interface, the monitor enters an interactive mode in which it processes commands received from the external device.

DSP Control Registers

The DSP core has a system control register, SYSCNTL, memory mapped at DM (0x3FFF). SPORT0 is enabled when Bit 12 is set, disabled when this bit is cleared. SPORT1 is enabled when Bit 11 is set, disabled when this bit is cleared. SPORT1 is configured as a serial port when Bit 10 is set, or as flags and interrupt lines when this bit is cleared. For proper operation of the ADMC331, all other bits in this register must be cleared (which is their default).

The DSP core has a wait state control register, MEMWAIT, memory mapped at DM (0x3FFE). For proper operation of the ADMC331, this register must always contain the value 0x8000 (which is the default).

The configuration of both the SYSCNTL and MEMWAIT registers of the ADMC331 is shown at the end of the data sheet.

THREE-PHASE PWM CONTROLLER

Overview

The PWM generator block of the ADMC331 is a flexible, programmable, three-phase PWM waveform generator that can be programmed to generate the required switching patterns to drive a three-phase voltage source inverter for ac induction (ACIM), or permanent magnet synchronous (PMSM) or a switched or variable reluctance (SRM) motor control. In addition, the PWM block contains special functions that considerably simplify the generation of the required PWM switching patterns for

control of the electronically commutated motor (ECM) or brushless dc motor (BDCM).

The PWM generator produces three pairs of PWM signals on the six PWM output pins (AH, AL, BH, BL, CH and CL). The six PWM output signals consist of three high side drive signals (AH, BH and CH) and three low side drive signals (AL, BL and CL). The polarity of the generated PWM signals may be programmed by the PWMPOL pin, so that either active HI or active LO PWM patterns can be produced by the ADMC331. The switching frequency, dead time and minimum pulsewidths of the generated PWM patterns are programmable using respectively the PWMTM, PWMDT and PWMPD registers. In addition, three duty cycle control registers (PWMCHA, PWMCHB and PWMCHC) directly control the duty cycles of the three pair of PWM signals.

When the PWMSR pin is pulled low, the PWM generator transforms the six PWM output signals into six waveforms for switched reluctance gate drive signals. The low side PWM signals from the three-phase timing unit assume permanently ON states, independent of the value written to the duty-cycle registers. The duty cycles of the high side PWM signals from the timing unit are still determined by the three duty-cycle registers.

Each of the six PWM output signals can be enabled or disabled by separate output enable bits of the PWMSEG register. In addition, three control bits of the PWMSEG register permit crossover of the two signals of a PWM pair for easy control of ECM or BDCM. In crossover mode, the PWM signal destined for the high side switch is diverted to the complementary low side output and the signal destined for the low side switch is diverted to the corresponding high side output signal.

In many applications, there is a need to provide an isolation barrier in the gate-drive circuits that turn on the power devices of the inverter. In general, there are two common isolation techniques, optical isolation using opto-couplers, and transformer isolation using pulse transformers. The PWM controller of the ADMC331 permits mixing of the output PWM signals with a high frequency chopping signal to permit easy interface to such pulse transformers. The features of this gate-drive chopping mode can be controlled by the PWMGATE register. There is an 8-bit value within the PWMGATE register that directly controls the chopping frequency. In addition, high frequency chopping can be independently enabled for the high side and the low side outputs using separate control bits in the PWMGATE register.

The PWM generator is capable of operating in two distinct modes, single update mode or double update mode. In single update mode, the duty cycle values are programmable only once per PWM period, so that the resultant PWM patterns are symmetrical about the midpoint of the PWM period. In the double update mode, a second updating of the PWM duty cycle values is implemented at the midpoint of the PWM period. In this mode, it is possible to produce asymmetrical PWM patterns, that produce lower harmonic distortion in three-phase PWM inverters. This technique also permits the closed loop controller to change the average voltage applied to the machine winding at a faster rate and so permits fast closed loop bandwidths to be achieved. The operating mode of the PWM block (single or double update mode) is selected by a control bit in MODECTRL register.

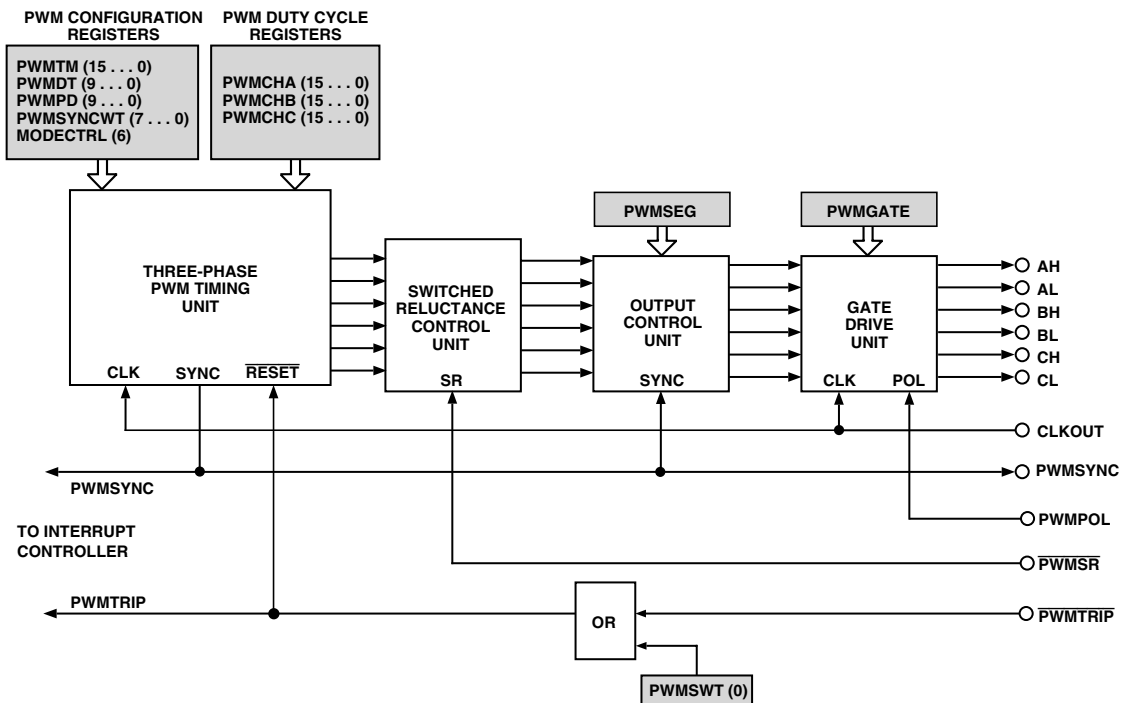

Figure 5. Overview of the PWM Controller of the ADMC331

The PWM generator of the ADMC331 also provides an output pulse on the PWMSYNC pin that is synchronized to the PWM switching frequency. In single update mode, a PWMSYNC pulse is produced at the start of each PWM period. In double update mode, an additional PWMSYNC pulse is produced at the midpoint of each PWM period. The width of the PWMSYNC pulse is programmable through the PWMSYNCWT register.

The PWM signals produced by the ADMC331 can be shut-off in two different ways. Firstly there is a dedicated asynchronous PWM shutdown pin, PWMTRIP, that when brought LO, instantaneously places all six PWM outputs in the OFF state (as determined by the state of the PWMPOL pin). This hardware shutdown mechanism is asynchronous so that the associated PWM disable circuitry does not go through any clocked logic, thereby ensuring correct PWM shutdown even in the event of a loss of DSP clock. In addition to the hardware shutdown feature, the PWM system may be shutdown in software by writing to the PWMSWT register.

Status information about the PWM system of the ADMC331 is available to the user in the SYSSTAT register. In particular, the state of the PWMTRIP, PWMPOL and PWMSR pins is available, as well as a status bit that indicates whether operation is in the first half or the second half of the PWM period.

A functional block diagram of the PWM controller is shown in Figure 5. The generation of the six output PWM signals on pins AH to CL is controlled by four important blocks:

- The Three-Phase PWM Timing Unit, which is the core of the PWM controller, generates three pairs of complemented and dead time adjusted center based PWM signals.

- The Switched Reluctance Control Unit transforms the three-phase outputs into six PWM wave forms for switched reluctance gate drive signals.
- The Output Control Unit allows the redirection of the outputs of the Three-Phase Timing Unit for each channel to either the high side or the low side output. In addition, the Output Control Unit allows individual enabling/disabling of each of the six PWM output signals.
- The GATE Drive Unit provides the correct polarity output PWM signals based on the state of the PWMPOL pin. The Gate Drive Unit also permits the generation of the high frequency chopping frequency and its subsequent mixing with the PWM signals.

The PWM controller is driven by a clock at the same frequency as the DSP instruction rate, CLKOUT, and is capable of generating two interrupts to the DSP core. One interrupt is generated on the occurrence of a PWMSYNC pulse and the other is generated on the occurrence of any PWM shutdown action.

Three-Phase Timing Unit

The 16-bit three-phase timing unit is the core of the PWM controller and produces three pair of pulsewidth modulated signals with high resolution and minimal processor overhead. The outputs of this timing unit are active LO such that a low level is interpreted as a command to turn ON the associated power device. There are four main configuration registers (PWMTM, PWMDT, PWMPD and PWMSYNCWT) that determine the fundamental characteristics of the PWM outputs. In addition, the operating mode of the PWM (single or double update mode) is selected by Bit 6 of the MODECTRL register.

ADMC331

These registers, in conjunction with the three 16-bit duty-cycle registers (PWMCHA, PWMCHB and PWMCHC), control the output of the three-phase timing unit.

PWM Switching Frequency, PWMTM Register

The PWM switching frequency is controlled by the 16-bit read/write PWM period register, PWMTM. The fundamental timing unit of the PWM controller is t_{CK} (DSP instruction rate). Therefore, for a 26 MHz CLKOUT, the fundamental time increment is 38.5 ns. The value written to the PWMTM register is effectively the number of t_{CK} clock increments in half a PWM period. The required PWMTM value is a function of the desired PWM switching frequency (f_{PWM}) and is given by:

$$PWMTM = \frac{f_{CLKOUT}}{2 \times f_{PWM}} = \frac{f_{CLKIN}}{f_{PWM}}$$

Therefore, the PWM switching period, T_S , can be written as:

$$T_S = 2 \times PWMTM \times t_{CK}$$

For example, for a 26 MHz CLKOUT and a desired PWM switching frequency of 10 kHz ($T_S = 100 \mu s$), the correct value to load into the PWMTM register is:

$$PWMTM = \frac{26 \times 10^6}{2 \times 10 \times 10^3} = 1300$$

The largest value that can be written to the 16-bit PWMTM register is 0xFFFF = 65,535 which corresponds to a minimum PWM switching frequency of:

$$f_{PWM, \min} = \frac{26 \times 10^6}{2 \times 65,535} = 198.4 \text{ Hz}$$

PWM Switching Dead Time, PWMDT Register

The second important parameter that must be set up in the initial configuration of the PWM block is the switching dead time. That is a short delay time introduced between turning off one PWM signal (AH) and turning on the complementary signal, AL. This short time delay is introduced to permit the power switch being turned off (AH in this case) to completely recover its blocking capability before the complementary switch is turned on. This time delay prevents a potentially destructive short-circuit condition from developing across the dc link capacitor of a typical voltage source inverter.

The dead time is controlled by the 10-bit, read/write PWMDT register. There is only one dead time register that controls the dead time inserted into the three pairs of PWM output signals. The dead time, T_D , is related to the value in the PWMDT register by:

$$T_D = PWMDT \times 2 \times t_{CK}$$

Therefore, a PWMDT value of 0x00A (= 10), introduces a 769.2 ns delay between the turn-off on any PWM signal (AH) and the turn-on of its complementary signal (AL). The amount of the dead time can therefore be programmed in increments of $2 t_{CK}$ (or 76.92 ns for a 26 MHz CLKOUT). The PWMDT register is a 10-bit register so that its maximum value is 0x3FF

(=1023) corresponding to a maximum programmed dead time of:

$$T_{D, \max} = 1023 \times 2 \times t_{CK} = 1023 \times 2 \times 38.46 \times 10^{-9} = 78.69 \mu s$$

for a CLKOUT rate of 26 MHz. Obviously, the deadtime can be programmed to be zero by writing 0 to the PWMDT register.

PWM Operating Mode, MODECTRL and SYSSTAT Registers

The PWM controller of the ADCM331 can operate in two distinct modes: single update mode and double update mode. The operating mode of the PWM controller is determined by the state of Bit 6 of the MODECTRL register. If this bit is cleared, the PWM operates in the single update mode. Setting Bit 6 places the PWM in the double update mode. By default, following either a peripheral reset or power on, Bit 6 of the MODECTRL register is cleared so that the default operating mode is in single update mode.

In single update mode, a single PWMSYNC pulse is produced in each PWM period. The rising edge of this signal marks the start of a new PWM cycle and is used to latch new values from the PWM configuration registers (PWMTM, PWMDT, PWMPD and PWMSYNCWT) and the PWM duty-cycle registers (PWMCHA, PWMCHB and PWMCHC) into the three-phase timing unit. In addition, the PWMSEG register is also latched into the output control unit on the rising edge of the PWMSYNC pulse. In effect, this means that the characteristics and resultant duty cycles of the PWM signals can be updated only once per PWM period at the start of each cycle. The result is that PWM patterns that are symmetrical about the midpoint of the switching period are produced.

In double update mode, there is an additional PWMSYNC pulse produced at the midpoint of each PWM period. The rising edge of this new PWMSYNC pulse is again used to latch new values of the PWM configuration registers, duty-cycle registers and the PWMSEG register. As a result it is possible to alter both the characteristics (switching frequency, dead time, minimum pulsewidth and PWMSYNC pulsewidth) as well as the output duty cycles at the midpoint of each PWM cycle. Consequently, it is possible to produce PWM switching patterns that are no longer symmetrical about the midpoint of the period (asymmetrical PWM patterns).

In the double update mode, it may be necessary to know whether operation at any point in time is in either the first half or the second half of the PWM cycle. This information is provided by Bit 3 of the SYSSTAT register, which is cleared during operation in the first half of each PWM period (between the rising edge of the original PWMSYNC pulse and the rising edge of the new PWMSYNC pulse introduced in double update mode). Bit 3 of the SYSSTAT register is set during operation in the second half of each PWM period. This status bit allows the user to make a determination of the particular half-cycle during implementation of the PWMSYNC interrupt service routine, if required.

The advantage of the double update mode is that lower harmonic voltages can be produced by the PWM process and faster control bandwidths are possible. However, for a given PWM switching frequency, the PWMSYNC pulses occur at twice the rate in the double update mode. Since new duty cycle values must be computed in each PWMSYNC interrupt service routine, there is a larger computational burden on the DSP in the double update mode.

Width of the PWMSYNC Pulse, PWMSYNCWT Register

The PWM controller of the ADCM331 produces an output PWM synchronization pulse at a rate equal to the PWM switching frequency in single update mode and at twice the PWM frequency in the double update mode. This pulse is available for external use at the PWMSYNC pin. The width of this PWMSYNC pulse is programmable by the 8-bit read/write PWMSYNCWT register. The width of the PWMSYNC pulse, $T_{PWMSYNC}$, is given by:

$$T_{PWMSYNC} = t_{CK} \times (PWMSYNCWT + 1)$$

so that the width of the pulse is programmable from t_{CK} to $256 t_{CK}$ (corresponding to 38.5 ns to 9.84 μ s for a CLKOUT rate of 26 MHz). Following a reset, the PWMSYNCWT register contains 0x27 (= 39) so that the default PWMSYNC width is 1.54 μ s, again for a 26 MHz CLKOUT.

PWM Duty Cycles, PWMCHA, PWMCHB, PWMCHC Registers

The duty cycles of the six PWM output signals on pins AH to CL are controlled by the three 16-bit read/write duty-cycle registers, PWMCHA, PWMCHB, and PWMCHC. The integer value in the register PWMCHA controls the duty cycle of the signals on AH and AL, in PWMCHB, controls the duty cycle of the signals on BH and BL and in PWMCHC, controls the duty cycle of the signals on CH and CL. The duty-cycle registers are programmed in integer counts of the fundamental time unit, t_{CK} , and define the desired on-time of the high side PWM signal produced by the three-phase timing unit over half the PWM period. The switching signals produced by the three-phase timing unit are also adjusted to incorporate the programmed dead time value in the PWMDT register. The three-phase timing unit produces active LO signals so that a LO level corresponds to a command to turn on the associated power device.

A typical pair of PWM outputs (in this case for AH and AL) from the timing unit are shown in Figure 6 for operation in single update mode. All illustrated time values indicate the integer value in the associated register and can be converted to time simply by multiplying by the fundamental time increment, t_{CK} . Firstly, it is noted that the switching patterns are perfectly symmetrical about the midpoint of the switching period in this single update mode since the same values of PWMCHA, PWMTM and PWMDT are used to define the signals in both half cycles of the period. It can be seen how the programmed duty cycles are adjusted to incorporate the desired dead time into the resultant pair of PWM signals. Clearly, the dead time is incorporated by moving the switching instants of both PWM signals (AH and AL) away from the instant set by the PWMCHA register. Both switching edges are moved by an equal amount ($PWMDT \times t_{CK}$) to preserve the symmetrical output patterns. Also shown is the PWMSYNC pulse whose width is set by the PWMSYNCWT register and Bit 3 of the SYSSTAT register, which indicates whether operation is in the first or second half cycle of the PWM period.

Obviously negative values of T_{AH} and T_{AL} are not permitted and the minimum permissible value is zero, corresponding to a 0% duty cycle. In a similar fashion, the maximum value is T_S , corresponding to a 100% duty cycle.

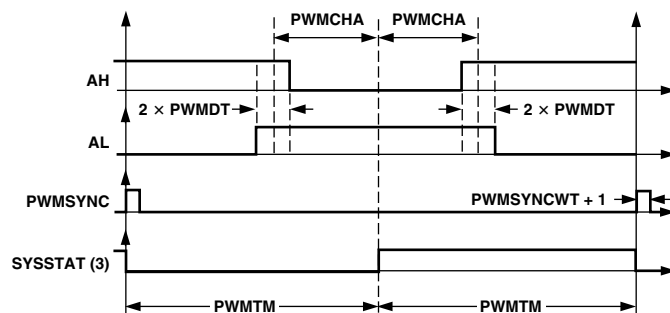

Figure 6. Typical PWM Outputs of Three-Phase Timing Unit in Single Update Mode (Active LO Waveforms)

The resultant on-times of the PWM signals in Figure 6 may be written as:

$$T_{AH} = 2 \times (PWMCHA - PWMDT) \times t_{CK}$$

$$T_{AL} = 2 \times (PWMTM - PWMCHA - PWMDT) \times t_{CK}$$

and the corresponding duty cycles are:

$$d_{AH} = \frac{T_{AH}}{T_S} = \frac{PWMCHA - PWMDT}{PWMTM}$$

$$d_{AL} = \frac{T_{AL}}{T_S} = \frac{PWMTM - PWMCHA - PWMDT}{PWMTM}$$

The output signals from the timing unit for operation in double update mode are shown in Figure 7. This illustrates a completely general case where the switching frequency, dead time and duty cycle are all changed in the second half of the PWM period. Of course, the same value for any or all of these quantities could be used in both halves of the PWM cycle. However, it can be seen that there is no guarantee that symmetrical PWM signal will be produced by the timing unit in this double update mode. Additionally, it is seen that the dead time is inserted into the PWM signals in the same way as in the single update mode.

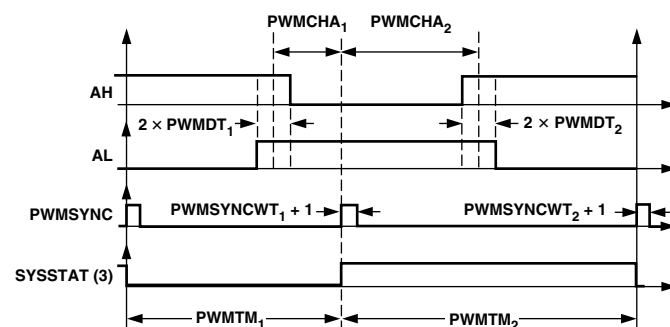

Figure 7. Typical PWM Outputs of Three-Phase Timing Unit in Double Update Mode (Active LO Waveforms)

In general, the on-times of the PWM signals in double update mode can be defined as:

$$T_{AH} = (PWMCHA_1 + PWMCHA_2 - PWMDT_1 - PWMDT_2) \times t_{CK}$$

$$T_{AL} = (PWMTM_1 + PWMTM_2 - PWMCHA_1 - PWMCHA_2 - PWMDT_1 - PWMDT_2) \times t_{CLK}$$

ADMC331

where the subscript 1 refers to the value of that register during the first half cycle and the subscript 2 refers to the value during the second half cycle. The corresponding duty cycles are:

$$d_{AH} = \frac{T_{AH}}{T_S} = \frac{(PWMCHA_1 + PWMCHA_2 - PWMDT_1 - PWMDT_2)}{(PWMTM_1 + PWMTM_2)}$$

$$d_{AL} = \frac{T_{AL}}{T_S} = \frac{(PWMTM_1 + PWMTM_2 - PWMCHA_1 - PWMCHA_2 - PWMDT_1 - PWMDT_2)}{(PWMTM_1 + PWMTM_2)}$$

since for the completely general case in double update mode, the switching period is given by:

$$T_S = (PWMTM_1 + PWMTM_2) \times t_{CK}$$

Again, the values of T_{AH} and T_{AL} are constrained to lie between zero and T_S .

Similar PWM signals to those illustrated in Figure 6 and Figure 7 can be produced on the BH, BL, CH and CL outputs by programming the PWMCHB and PWMCHC registers in a manner identical to that described for PWMCHA.

The PWM controller does not produce any PWM outputs until all of the PWMTM, PWMCHA, PWMCHB and PWMCHC registers have been written to at least once. Once these registers have been written, internal counting of the timers in the three-phase timing unit is enabled.

Effective PWM Resolution

In single update mode, the same value of PWMCHA, PWMCHB and PWMCHC are used to define the on-times in both half cycles of the PWM period. As a result, the effective resolution of the PWM generation process is $2 t_{CK}$ (or 76.9 ns for a 26 MHz CLKOUT) since incrementing one of the duty-cycle registers by 1 changes the resultant on-time of the associated PWM signals by t_{CK} in each half period (or $2 t_{CK}$ for the full period).

In double update mode, improved resolution is possible since different values of the duty cycles registers are used to define the on-times in both the first and second halves of the PWM period. As a result, it is possible to adjust the on-time over the whole period in increments of t_{CK} . This corresponds to an effective PWM resolution of t_{CK} in double update mode (or 38.5 ns for a 26 MHz CLKOUT).

The achievable PWM switching frequency at a given PWM resolution is tabulated in Table V.

Table V. Achievable PWM Resolution in Single and Double Update Modes

Resolution (Bit)	Single Update Mode PWM Frequency (kHz)	Double Update Mode PWM Frequency (kHz)
8	50.7	101.5
9	25.4	50.7
10	12.7	25.4
11	6.3	12.7
12	3.2	6.3

Minimum Pulsewidth, PWMPD Register

In many power converter switching applications, it is desirable to eliminate PWM switching signals below a certain width. It takes a certain finite time to both turn on and turn off modern

power semiconductor devices. Therefore, if the width of any of the PWM signals goes below some minimum value, it may be desirable to completely eliminate the PWM switching for that particular cycle.

The allowable minimum on-time for any of the six PWM outputs over half a PWM period that can be produced by the PWM controller may be programmed using the 10-bit read/write PWMPD register. The minimum on-time is programmed in increments of t_{CK} so that the minimum on-time that will be produced over any half PWM period, T_{MIN} , is related to the value in the PWMPD register by:

$$T_{MIN} = PWMPD \times t_{CK}$$

so that a PWMPD value of 0x002 defines a permissible minimum on-time of 76.9 ns for a 26 MHz CLKOUT.

In each half cycle of the PWM, the timing unit checks the on-time of each of the six PWM signals. If any of the times are found to be less than the value specified by the PWMPD register, the corresponding PWM signal is turned OFF for the entire half period and its complementary signal is turned completely ON.

Consider the example where $PWMTM = 200$, $PWMCHA = 5$, $PWMDT = 3$, $PWMPD = 10$ with a CLKOUT of 26 MHz and operation in single update mode. In this case, the PWM switching frequency is 65 kHz and the dead time is 230 ns. The permissible on-time of any PWM signal over one half of any period is 384.6 ns. Clearly, for this example, the dead time adjusted on-time of the AH signal over half a PWM period is $(5-3) \times 38.5 \text{ ns} = 77 \text{ ns}$. This is less than the permissible value, so the timing unit will output a completely OFF (0% duty cycle) signal on AH. Additionally, the AL signal will be turned ON for the entire half period (100% duty cycle).

Switched Reluctance Mode

The PWM block of the ADMC331 contains a switched reluctance mode that is controlled by the state of the \overline{PWMSR} pin. The switched reluctance (SR) mode is enabled by connecting the \overline{PWMSR} pin to GND. In this SR mode, the low side PWM signals from the three-phase timing unit assume permanently ON states, independent of the value written to the duty-cycle registers. The duty cycles of the high side PWM signals from the timing unit are still determined by the three duty-cycle registers. Using the crossover feature of the output control unit, it is possible to divert the permanently ON PWM signals to either the high side or the low side outputs. This mode is necessary because in the typical power converter configuration for switched or variable reluctance motors, the motor winding is connected between the two power switches of a given inverter leg. Therefore, in order to build up current in the motor winding, it is necessary to turn on both switches at the same time. Typical active LO PWM signals during operation in SR mode are shown in Figure 8 for operation in double update mode. It is clear that the three low side signals (AL, BL and CL) are permanently ON and the three high side signals are modulated so that the corresponding high side power switches are switched between the ON and OFF states.

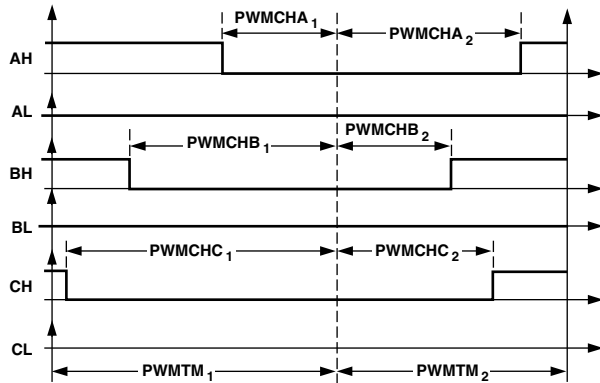

Figure 8. Active LO PWM signals in SR Mode ($PWMPOL = \overline{PWMSR} = GND$) for ADMC331 in double update mode. The signals from the three-phase unit are not crossed over ($PWMSEG = 0$) and the dead time is zero ($PWMDT = 0$).

The SR mode can only be enabled by connecting the \overline{PWMSR} pin to GND. There is no software means by which this mode can be enabled. There is an internal pull-up resistor on the \overline{PWMSR} pin so that if this pin is left unconnected or becomes disconnected the SR mode is disabled. Of course, the SR mode is disabled when the \overline{PWMSR} pin is tied to V_{DD} . The state of the \overline{PWMSR} pin may be read from Bit 4 of the SYSSTAT register.

Output Control Unit, PWMSEG Register

The operation of the Output Control Unit is controlled by the 9-bit read/write PWMSEG register that controls two distinct features that are directly useful in the control of ECM or BDCM.

The PWMSEG register contains three crossover bits, one for each pair of PWM outputs. Setting Bit 8 of the PWMSEG register enables the crossover mode for the AH/AL pair of PWM signals; setting Bit 7 enables crossover on the BH/BL pair of PWM signals; setting Bit 6 enables crossover on the CH/CL pair of PWM signals. If crossover mode is enabled for any pair of PWM signals, the high side PWM signal from the timing unit (i.e. AH) is diverted to the associated low side output of the Output Control Unit so that the signal will ultimately appear at the AL pin. Of course, the corresponding low side output of the Timing Unit is also diverted to the complementary high side output of the Output Control Unit so that the signal appears at the AH pin. Following a reset, the three crossover bits are cleared so that the crossover mode is disabled on all three pairs of PWM signals.

The PWMSEG register also contains six bits (Bits 0 to 5) that can be used to individually enable or disable each of the six PWM outputs. The PWM signal of the AL pin is enabled by setting Bit 5 of the PWMSEG register while Bit 4 controls AH, Bit 3 controls BL, Bit 2 controls BH, Bit 1 controls CL and Bit 0 controls the CH output. If the associated bit of the PWMSEG register is set, then the corresponding PWM output is disabled irrespective of the value of the corresponding duty cycle register. This PWM output signal will remain in the OFF state as long as the corresponding enable/disable bit of the PWMSEG register is set. The implementation of this output enable function is implemented after the crossover function. Following a reset, all six enable bits of the PWMSEG register are cleared so that all PWM outputs are enabled by default.

In a manner identical to the duty-cycle registers, the PWMSEG is latched on the rising edge of the PWMSYNC signal so that the changes to this register only become effective at the start of each PWM cycle in single update mode. In double update mode, the PWMSEG register can also be updated at the midpoint of the PWM cycle.

In the control of an ECM, only two inverter legs are switched at any time and often the high side device in one leg must be switched ON at the same time as the low side driver in a second leg. Therefore, by programming identical duty cycles values for two PWM channels (i.e., $PWMCHA = PWMCHB$) and setting Bit 7 of the PWMSEG register to crossover the BH/BL pair if PWM signals, it is possible to turn ON the high side switch of phase A and the low side switch of Phase B at the same time. In the control of ECM, it is usual that the third inverter leg (Phase C in this example) be permanently disabled for a number of PWM cycles. This function is implemented by disabling both the CH and CL PWM outputs by setting Bits 0 and 1 of the PWMSEG register. This situation is illustrated in Figure 9 where it can be seen that both the AH and BL signals are identical, since $PWMCHA = PWMCHB$ and the crossover bit for Phase B is set. In addition, the other four signals (AL, BH, CH and CL) have been disabled by setting the appropriate enable/disable bits of the PWMSEG register. For the situation illustrated in Figure 9, the appropriate value for the PWMSEG register is 0x00A7. In normal ECM operation, each inverter leg is disabled for certain periods of time, so that the PWMSEG register is changed based on the position of the rotor shaft (motor commutation).

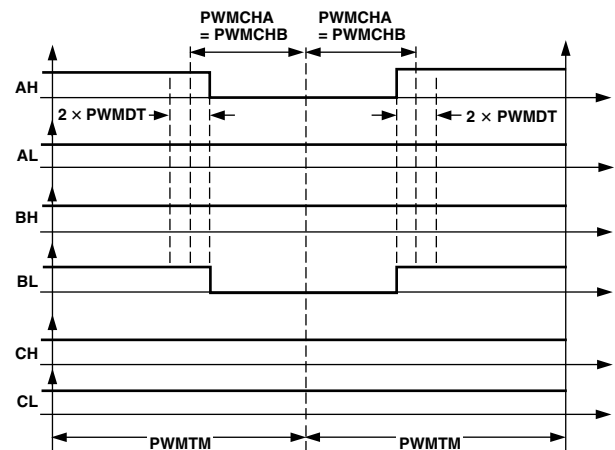

Figure 9. Example active LO PWM signals suitable for ECM control, $PWMCHA = PWMCHB$, crossover BH/BL pair and disable AL, BH, CH and CL outputs. Operation is in single update mode.

Gate Drive Unit, PWMGATE Register

The Gate Drive Unit of the PWM controller adds features that simplify the design of isolated gate drive circuits for PWM inverters. If a transformer-coupled power device gate driver amplifier is used, the active PWM signals must be chopped at a high frequency. The 10-bit read/write PWMGATE register allows the programming of this high frequency chopping mode. The chopped active PWM signals may be required for the high side drivers only, for the low side drivers only or for both the high side and low side switches. Therefore, independent control of this mode for both high and low side switches is

ADMC331

included with two separate control bits in the PWMGATE register.

Typical PWM output signals with high frequency chopping enabled on both high side and low side signals are shown in Figure 10. Chopping of the high side PWM outputs (AH, BH and CH) is enabled by setting Bit 8 of the PWMGATE register. Chopping of the low side PWM outputs (AL, BL and CL) is enabled by setting Bit 9 of the PWMGATE register. The high frequency chopping frequency is controlled by the 8-bit word (GDCLK) placed in Bits 0 to 7 of the PWMGATE register. The period of this high frequency carrier is:

$$T_{CHOP} = [4 \times (GDCLK + 1)] \times t_{CK}$$

$$f_{CHOP} = \frac{f_{CLKOUT}}{[4 \times (GDCLK + 1)]}$$

The GDCLK value may range from 0 to 255, corresponding to a programmable chopping frequency rate from 25.39 kHz to 6.5 MHz for a 26 MHz CLKOUT rate. The gate drive features must be programmed before operation of the PWM controller and typically are not changed during normal operation of the PWM controller. Following a reset, all bits of the PWMGATE register are cleared so that high frequency chopping is disabled, by default.

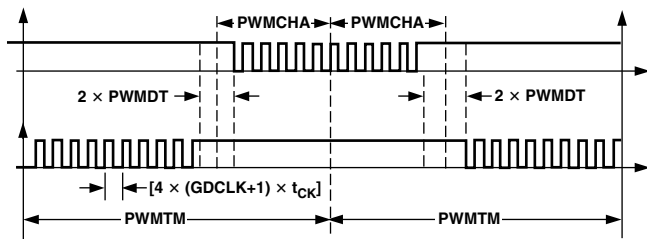

Figure 10. Typical Active LO PWM Signals with High Frequency Gate Chopping Enabled on Both High Side and Low Side Switches

PWM Polarity Control, PWMPOL Pin

The polarity of the PWM signals produced at the output pins AH to CL may be selected in hardware by the PWMPOL pin. Connecting the PWMPOL pin to GND selects active LO PWM outputs, such that a LO level is interpreted as a command to turn on the associated power device. Conversely, connecting V_{DD} to PWMPOL pin selects active HI PWM and the associated power devices are turned ON by a HI level at the PWM outputs. There is an internal pull-up on the PWMPOL pin, so that if this pin becomes disconnected (or is not connected), active HI PWM will be produced. The level on the PWMPOL pin may be read from Bit 2 of the SYSSTAT register, where a zero indicated a measure LO level at the PWMPOL pin.

PWM Shutdown

In the event of external fault conditions, it is essential that the PWM system be instantaneously shut down in a safe fashion. A falling edge on the PWMTRIP pin provides an instantaneous, asynchronous (independent of the DSP clock) shutdown of the PWM controller. All six PWM outputs are placed in the OFF state (as defined by the PWMPOL pin). In addition, the PWMSYNC pulse is disabled and the associated interrupt is stopped. The PWMTRIP pin has an internal pull-down resistor so that if the pin becomes disconnected the PWM will be disabled.

The state of the PWMTRIP pin can be read from Bit 0 of the SYSSTAT register.

In addition, it is possible to initiate a PWM shutdown in software by writing to the 1-bit read/write PWMSWT register. The act of writing to this register generates a PWM shutdown command in a manner identical to the PWMTRIP pin. It does not matter which value is written to the PWMSWT register. However, following a PWM shutdown, it is possible to read the PWMSWT register to determine if the shutdown was generated by hardware or software. Reading the PWMSWT register automatically clears its contents.

On the occurrence of a PWM shutdown command (either from the PWMTRIP pin or the PWMSWT register), a PWMTRIP interrupt will be generated. In addition, internal timing of the three-phase timing unit of the PWM controller is stopped. Following a PWM shutdown, the PWM can only be re-enabled (in a PWMTRIP interrupt service routine, for example) by writing to all of the PWTM, PWMCHA, PWMCHB and PWMCHC registers. Provided the external fault has been cleared and the PWMTRIP has returned to a HI level, internal timing of the three-phase timing unit resumes and new duty cycle values are latched on the next PWMSYNC boundary.

PWM Registers

The configuration of the PWM registers is described at the end of the data sheet.

ADC OVERVIEW

The Analog Input Block of the ADCM331 is a 7-channel single slope Analog Data Acquisition System with 12-bit resolution. Data Conversion is performed by timing the crossover between the Analog Input and Sawtooth Reference Ramp. A simple voltage comparator detects the crossover and latches the timed counter value into a channel-specific output register

The ADC system is comprised of seven input channels to the ADC of which three (V1, V2, V3) have dedicated comparators. The remaining four channels (VAUX0, VAUX1, VAUX2, VAUX3) are multiplexed into the fourth comparator and are selected using the ADCMUX0 and ADCMUX1 bits of the MODECTRL register (Table VI). This allows four conversions to be performed by the ADC between successive PWMSYNC pulses.

Table VI. ADC Auxiliary Channel Selection

Select	MODECTRL (1) ADCMUX1	MODECTRL (0) ADCMUX0
VAUX0	0	0
VAUX1	0	1
VAUX2	1	0
VAUX3	1	1

Analog Block

The operation of the ADC block may be explained by reference to Figures 11 and 12. The reference ramp is tied to one input of each of the four comparators. This reference ramp is generated by charging an external timing capacitor with a constant current source. The timing capacitor is connected between pins CAPIN and SGND. The capacitor voltage is reset at the start of each PWMSYNC pulse, which by default is held high for 40 CLKOUT cycles (T_{CRST} = 1.54 μs for a 26 MHz CLKOUT). On the falling edge of PWMSYNC, the capacitor begins to charge at a rate

determined by the capacitor and the current source values. An internal current source is made available for connection to the external timing capacitor on the ICONST pin. An external timing capacitor could also be used, if required. The four input comparators of the ADC block continuously compare the values of the four analog inputs with the capacitor voltage. Each comparator output will go high when the capacitor voltage exceeds the respective analog input voltage.

ADC Timer Block

The ADC timer block consists of a 12-bit counter clocked at a rate determined by the ADCCNT bit in the MODECTRL register. If ADCCNT is 0, the counter is clocked at twice the CLKOUT period, or if ADCCNT is 1, the counter is clocked at the CLKOUT period. Thus at the maximum CLKOUT frequency of 26 MHz, this gives a timer resolution of 76.9 ns when ADCCNT is 0, and 38.5 ns when ADCCNT is 1. The counter is reset during the high PWMSYNC pulse so that the counter commences at the beginning of the reference voltage ramp. When the output of a given comparator goes high, the counter value is latched into the appropriate 12-bit ADC register. There are four pair of ADC registers (ADC1, ADC2, ADC3 and ADCAUX) corresponding to each of the four comparators. Each comparator's register pair is organized as master/slave or master/shadow. At the end of the reference voltage ramp, which is prior to the next PWMSYNC, all four master registers have been loaded with the new conversion count. At the rising edge of the PWMSYNC, the registered conversion count for each channel is loaded into the DSP readable shadow registers, ADC1, ADC2, ADC3, and ADCAUX. The controller will then read these shadow registers containing the previous PWM period conversion count, while internally the master registers will be loaded with the current PWM period conversion count.

The first set of values loaded into the output registers after the first PWMSYNC interrupt will be invalid since the latched value is indeterminate. Also, if the input analog voltage exceeds the peak capacitor ramp voltage, the comparator output will be permanently low and a 0xFFFF0 code will be produced. This indicates an input overvoltage condition.

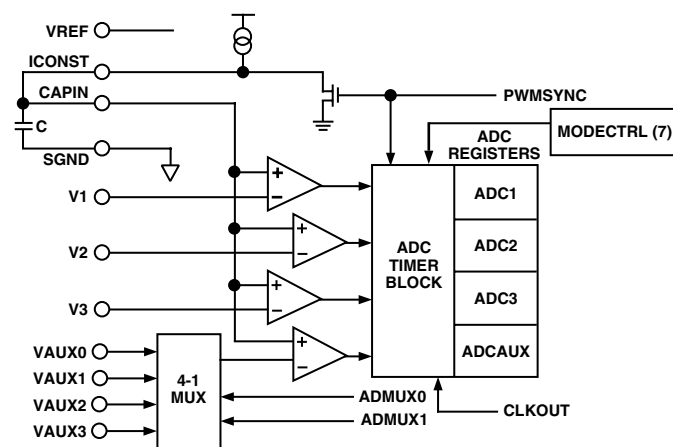

Figure 11. ADC Overview

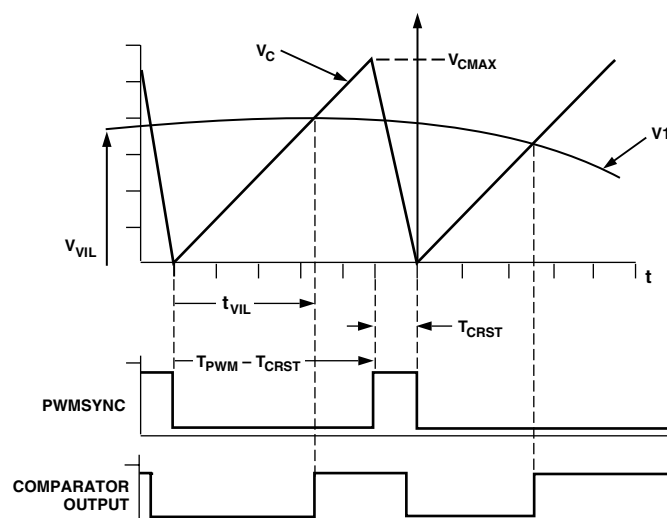

Figure 12. Analog Input Block Operation

ADC Resolution

Because the operation of the ADC is intrinsically linked to the PWM block, the effective resolution of the ADC is a function of the PWM switching frequency. The effective ADC resolution is determined by the rate at which the counter timer is clocked, which is selectable by the ADCCNT Bit 7 in MODECTRL register. For a CLKOUT period of t_{CK} and a PWM period of T_{PWM} , the maximum count of the ADC is given by:

$$\begin{aligned} \text{Max Count} &= \min(4095, (T_{PWM} - T_{CRST})/2 t_{CK}) && \text{MODECTRL Bit 7} = 0 \\ \text{Max Count} &= \min(4095, (T_{PWM} - T_{CRST})/t_{CK}) && \text{MODECTRL Bit 7} = 1 \end{aligned}$$

For an assumed CLKOUT frequency of 26 MHz and PWM-SYNC pulsewidth of 1.54 μ s, the effective resolution of the ADC block is tabulated for various PWM switching frequencies in Table VII.

Table VII. ADC Resolution Examples

PWM Freq. (kHz)	MODECTRL[7] = 0		MODECTRL[7] = 1	
	Max Count	Effective Resolution	Max Count	Effective Resolution
2.5	4095	12	4095	12
4	3230	>11	4095	12
8	1605	>10	3210	>11
18	702	>9	1404	>10
24	521	>9	1043	>10

External Timing Capacitor

In order to maximize the useful input voltage range and effective resolution of the ADC, it is necessary to carefully select the value of the external timing capacitor. For a given capacitance value, C_{NOM} , the peak ramp voltage is given by:

$$V_C \text{ max} = \frac{I_{CONST}(T_{PWM} - T_{CRST})}{C_{NOM}}$$

where I_{CONST} is the nominal current source value of 13.5 μ A and T_{CRST} is the PWMSYNC pulsewidth. In selecting the capacitor value, however, it is necessary to take into account the tolerance of the capacitor and the variation of the current source value.

ADMC331

To ensure that the full input range of the ADC is utilized, it is necessary to select the capacitor so that at the maximum capacitance value and the minimum current source output, the ramp voltage will charge to at least 3.5 V.

As a result, assuming $\pm 10\%$ variations in both the capacitance and current source, the nominal capacitance value required at a given PWM period is:

$$C_{NOM} = \frac{(0.9 \times I_{CONST})(T_{PWM} - T_{CRST})}{(1.1)(3.5)}$$

The largest standard value capacitor that is less than this calculated value is chosen. Table VIII shows the appropriate standard capacitor value to use for various PWM switching frequencies assuming $\pm 10\%$ variations in both the current source and capacitor tolerances. If required, more precise control of the ramp voltage is possible by using higher precision capacitor components, an external current source and/or series or parallel timing capacitor combinations.

Table VIII. Timing Capacitor Selection

PWM Frequency (kHz) MODECTRL[6] = 0	PWM Frequency (kHz) MODECTRL[6] = 1	Timing Capacitor (pF)
2.1–2.7	4.2–5.2	1500
2.7–3.2	5.2–6.3	1200
3.2–3.9	6.3–7.7	1000
3.9–4.7	7.7–9.2	820
4.7–5.6	9.2–11.2	680
5.6–6.7	11.2–13.3	560
6.7–8.0	13.3–16.0	470
8.0–9.5	16.0–18.8	390
9.5–11.5	18.8–23.0	330
11.5–14.1	23.0–28.1	270
14.1–17.1	28.1–34.1	220
17.1–20.4	34.1–40.8	180
20.4–25.3	40.8–50.6	150
25.3–30.1	50.6–60.2	120

ADC Registers

The configuration of all registers of the ADC System is shown at the end of the data sheet.

AUXILIARY PWM TIMERS

Overview

The ADCM331 provides two variable-frequency, variable duty cycle, 8-bit, auxiliary PWM outputs that are available at the AUX1 and AUX0 pins. These auxiliary PWM outputs can be used to provide switching signals to other circuits in a typical motor control system such as power factor corrected front-end converters or other switching power converters. Alternatively, by addition of a suitable filter network, the auxiliary PWM output signals can be used as simple single-bit digital-to-analog converters.

The auxiliary PWM system of the ADCM331 can operate in two different modes, independent mode or offset mode. The operating mode of the auxiliary PWM system is controlled by Bit 8 of the MODECTRL register. Setting Bit 8 of the MODECTRL register places the auxiliary PWM system in the

independent mode. In this mode, the two auxiliary PWM generators are completely independent and separate switching frequencies and duty cycles may be programmed for each auxiliary PWM output. In this mode, the 8-bit AUXTM0 register sets the switching frequency of the signal at the AUX0 output pin. Similarly, the 8-bit AUXTM1 register sets the switching of the signal at the AUX1 pin. The fundamental time increment for the auxiliary PWM outputs is twice the DSP instruction rate (or $2 t_{CK}$) so that the corresponding switching periods are given by:

$$T_{AUX0} = 2 \times (AUXTM0 + 1) \times t_{CK}$$

$$T_{AUX1} = 2 \times (AUXTM1 + 1) \times t_{CK}$$

Since the values in both AUXTM0 and AUXTM1 can range from 0 to 0xFF, the achievable switching frequency of the auxiliary PWM signals may range from 50.8 kHz to 13 MHz for a CLKOUT frequency of 26 MHz.

The on-time of the two auxiliary PWM signals is programmed by the two 8-bit AUXCH0 and AUXCH1 registers, according to:

$$T_{ON, AUX0} = 2 \times (AUXCH0) \times t_{CK}$$

$$T_{ON, AUX1} = 2 \times (AUXCH1) \times t_{CK}$$

so that output duty cycles from 0% to 100% are possible. Duty cycles of 100% are produced if the on-time value exceeds the period value. Typical auxiliary PWM waveforms in independent mode are shown in Figure 13(a).

When Bit 8 of the MODECTRL register is cleared, the auxiliary PWM channels are placed in offset mode. In offset mode, the switching frequency of the two signals on the AUX0 and AUX1 pins are identical and controlled by AUXTM0 in a manner similar to that previously described for independent mode. In addition, the on times of both the AUX0 and AUX1 signals are controlled by the AUXCH0 and AUXCH1 registers as before. However, in this mode the AUXTM1 register defines the offset time from the rising edge of the signal on the AUX0 pin to that on the AUX1 pin according to:

$$T_{OFFSET} = 2 \times (AUXTM1 + 1) \times t_{CK}$$

For correct operation in this mode, the value written to the AUXTM1 register must be less than the value written to the AUXTM0 register. Typical auxiliary PWM waveforms in offset mode are shown in Figure 13(b). Again, duty cycles from 0% to 100% are possible in this mode.

In both operating modes, the resolution of the auxiliary PWM system is 8-bit only at the minimum switching frequency ($AUXTM0 = AUXTM1 = 255$ in independent mode, $AUXTM0 = 255$ in offset mode). Obviously as the switching frequency is increased the resolution is reduced.

Values can be written to the auxiliary PWM registers at any time. However, new duty cycle values written to the AUXCH0 and AUXCH1 registers only become effective at the start of the next cycle. Writing to the AUXTM0 or AUXTM1 registers cause the internal timers to be reset to 0 and new PWM cycles begin.

By default, following power on or a reset, Bit 8 of the MODECTRL register is cleared so that offset mode is enabled. In addition, the registers AUXTM0 and AUXTM1 default to 0xFF, corresponding to minimum switching frequency and zero offset. In addition, the on-time registers AUXCH0 and AUXCH1 default to 0x00.

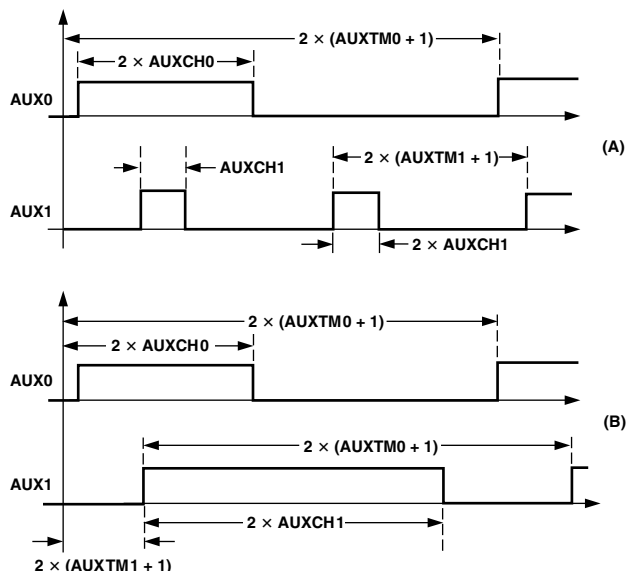

Figure 13. Typical Auxiliary PWM Signals in (a) Independent Mode and (b) Offset Mode (All Times in Increments of t_{CK})

Auxiliary PWM Interface, Registers and Pins

The registers of the auxiliary PWM system are summarized at the end of the data sheet.

PWM DAC Equation

The PWM output can be filtered in order to produce a low frequency analog signal between 0 V to 4.98 V dc. For example, a 2-pole filter with a 1.2 kHz cutoff frequency will sufficiently attenuate the PWM carrier. Figure 14 shows how the filter would be applied.

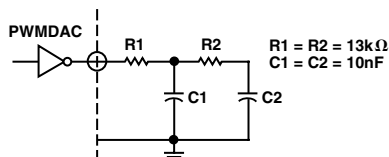

Figure 14. Auxiliary PWM Output Filter

WATCHDOG TIMER

The ADMC331 incorporates a watchdog timer that can perform a full reset of the DSP and motor control peripherals in the event of software error. The watchdog timer is enabled by writing a timeout value to the 16-bit WDTIMER register. The timeout value represents the number of CLKIN cycles required for the watchdog timer to count down to zero. When the watchdog timer reaches zero, a full DSP core and motor control peripheral reset is performed. In addition, Bit 1 of the SYSSTAT register is set so that after a watchdog reset the ADMC331 can determine that the reset was due to the timeout of the watchdog timer and not an external reset. Following a watchdog reset, Bit 1 of the SYSSTAT register may be cleared by writing zero to the WDTIMER register. This clears the status bit but does not enable the watchdog timer.

On reset, the watchdog timer is disabled and is only enabled when the first timeout value is written to the WDTIMER register. To prevent the watchdog timer from timing out, the user must write to the WDTIMER register at regular intervals

(shorter than the programmed WDTIMER period value). On all but the first write to WDTIMER, the particular value written to the register is unimportant since writing to WDTIMER simply reloads the first value written to this register. The WDTIMER register is memory mapped to data memory at location 0x2018.

PROGRAMMABLE DIGITAL INPUT/OUTPUT

The ADMC331 has 24 programmable digital I/O (PIO) pins: PIO0–PIO23. Each pin can be individually configurable as either an input or an output. Input pins can also be used to generate interrupts. Each PIO pin includes an internal pull-down resistor.

The PIO pins are configured as input or output by setting the appropriate bits in the PIODIR0, PIODIR1 and PIODIR2 registers. The read/write registers PIODATA0, PIODATA1 and PIODATA2 are used to set the state of an output pin or read the state of an input pin. Writing to PIODATA0, PIODATA1 and PIODATA2 affects only the pins configured as outputs. The default state, after an ADMC331 reset, is that all PIOs are configured as inputs.

Any pin can be configured as an independent edge-triggered interrupt source. The pin must first be configured as an input and then the appropriate bit must be set in the PIOINTEN0, or PIOINTEN1 or PIOINTEN2 registers. A peripheral interrupt is generated when the input level changes on any PIO pin configured as an interrupt source. A PIO interrupt sets the appropriate bit in the PIOFLAG0, or PIOFLAG1 or PIOFLAG2 registers. The DSP peripheral interrupt service routine (ISR) must read the PIOFLAG0, PIOFLAG1 and PIOFLAG2 registers to determine which PIO pin was the source of the PIO interrupt. Reading the PIOFLAG0, PIOFLAG1 and PIOFLAG2 registers will clear them.

PIO Registers

The configuration of all registers of the PIO system is shown at the end of the data sheet.

INTERRUPT CONTROL

The ADMC331 can respond to 34 different interrupt sources with minimal overhead. Eight of these interrupts are internal DSP core interrupts and twenty six are from the Motor Control Peripherals. The eight DSP core interrupts are SPORT0 receive and transmit, SPORT1 receive (or $\overline{IRQ0}$) and transmit (or $\overline{IRQ1}$), the internal timer and two software interrupts. The Motor Control interrupts are the 24 peripheral I/Os and two from the PWM (PWMSYNC pulse and PWMTRIP). All motor control interrupts are multiplexed into the DSP core via the peripheral $\overline{IRQ2}$ interrupt. They are also internally prioritized and individually maskable. The start address in the interrupt vector table for the ADMC331 interrupt sources is shown in Table VII. The interrupts are listed from high priority to the lowest priority.

The PWMSYNC interrupt is triggered by a low-to-high transition on the PWMSYNC pulse. The PWMTRIP interrupt is triggered on a high-to-low transition on the PWMTRIP pin. A PIO interrupt is detected on any change of state (high-to-low or low-to-high) on the PIO lines.

ADMC331

The entire interrupt control system of the ADC331 is configured and controlled by the IFC, IMASK and ICNTL registers of the DSP core and the IRQFLAG register for the PWMSYNC and PWMTRIP interrupts and PIOFLAG0, PIOFLAG1 and PIOFLAG2 registers for the PIO interrupts.

Table IX. Interrupt Vector Addresses

Interrupt Source	Interrupt Vector Address
Reset	0x0000 (Reserved)
PWMTRIP	0x002C (Highest Priority)
Peripheral Interrupt ($\overline{\text{IRQ2}}$)	0x0004
PWMSYNC	0x000C
PIO	0x0008
SPORT0 Transmit	0x0010
SPORT0 Receive	0x0014
Software Interrupt 1	0x0018
Software Interrupt 0	0x001C
SPORT1 Transmit Interrupt or $\overline{\text{IRQ1}}$	0x0020
SPORT1 Receive Interrupt or $\overline{\text{IRQ0}}$	0x0024
Timer	0x0028 (Lowest Priority)

Interrupt Masking

Interrupt masking (or disabling) is controlled by the IMASK register of the DSP core. This register contains individual bits that must be set to enable the various interrupt sources. If any peripheral interrupt is to be enabled, the $\overline{\text{IRQ2}}$ interrupt enable bit (Bit 9) of the IMASK register must be set. The configuration of the IMASK register of the ADC331 is shown at the end of the data sheet.

Interrupt Configuration

The IFC and ICNTL registers of the DSP core control and configure the interrupt controller of the DSP core. The IFC register is a 16-bit register that may be used to force and/or clear any of the eight DSP interrupts. Bits 0 to 7 of the IFC register may be used to clear the DSP interrupts while Bits 8 to 15 can be used to force a corresponding interrupt. Writing to Bits 11 and 12 in IFC is the only way to create the two software interrupts.

The ICNTL register is used to configure the sensitivity (edge- or level-) of the $\overline{\text{IRQ0}}$, $\overline{\text{IRQ1}}$ and $\overline{\text{IRQ2}}$ interrupts and to enable/disable interrupt nesting. Setting Bit 0 of ICNTL configures the $\overline{\text{IRQ0}}$ as edge-sensitive, while clearing the bit configures it for level-sensitive. Bit 1 is used to configure the $\overline{\text{IRQ1}}$ interrupt and Bit 2 is used to configure the $\overline{\text{IRQ2}}$ interrupt. It is recommended that the $\overline{\text{IRQ2}}$ interrupt always be configured for level-sensitive as this ensures that no peripheral interrupts are lost. Setting Bit 4 of the ICNTL register enables interrupt nesting. The configuration of both IFC and ICNTL registers is shown at the end of the data sheet.

Interrupt Operation

Following a reset, the ROM code monitor of the ADC331 copies a default interrupt vector table into program memory RAM from address 0x0000 to 0x002F. Since each interrupt source has a dedicated four-word space in this vector table, it is possible to code short interrupt service routines (ISR) in place. Alternatively, it may be required to insert a JUMP instruction to the appropriate start address of the interrupt service routine if more memory is required for the ISR.

On the occurrence of an interrupt, the program sequencer ensures that there is no latency (beyond synchronization delay) when processing unmasked interrupts. In the case of the timer, SPORT0, SPORT1 and software interrupts, the interrupt controller automatically jumps to the appropriate location in the interrupt vector table. At this point, a JUMP instruction to the appropriate ISR is required.

In the event of a motor control peripheral interrupt, the operation is slightly different. When a peripheral interrupt is detected, a bit is set in the IRQFLAG register for PWMSYNC and PWMTRIP or in the PIOFLAG0, or PIOFLAG1 or PIOFLAG2 registers for a PIO interrupt, and the $\overline{\text{IRQ2}}$ line is pulled low until all pending interrupts are acknowledged. For any of the twenty six peripheral interrupts, the interrupt controller automatically jumps to location 0x0004 in the interrupt vector table. Code loaded at location 0x0004 by the monitor on reset subsequently reads the IRQFLAG register to determine if the source of the interrupt was a PWM trip, PWMSYNC or PIOs and vectors to the appropriate interrupt vector location.

The code located at location 0x0004 by the monitor on reset is as follows:

```
0x0004: ASTAT = DM(IRQFLAG);
        DM(IRQFLAG_SAVE) = ASTAT;
        IF EQ JUMP 0x002C
        IF LT JUMP 0x000C;
```

At this point, a JUMP instruction to the appropriate ISR, at the interrupt vector location shown in Table IX, is required. If more than one interrupt occurs simultaneously, the higher priority interrupt service routine is executed. Reading the IRQFLAG register clears the PWMTRIP and PWMSYNC bits and acknowledges the interrupt, thus allowing further interrupts when the ISR exits. When the IRQFLAG register is read, it is saved in a data memory variable so the user ISR can check to see if there are simultaneous PWMSYNC and PWMTRIP interrupts.

A user's PIO interrupt service routine must read the PIOFLAG0, PIOFLAG1 and PIOFLAG2 registers to determine which PIO port is the source of the interrupt. Reading PIOFLAG0, PIOFLAG1 and PIOFLAG2 registers clear all bits in the registers and acknowledge the interrupt, thus allowing further interrupts when the ISR exits.

The configuration of all these registers is shown at the end of the data sheet.

SYSTEM CONTROLLER

The system controller block of the ADC331 performs a number of distinct functions:

1. Manages the interface and data transfer between the DSP core and the motor control peripherals.
2. Handles interrupts generated by the motor control peripherals and generates a DSP core interrupt signal $\overline{\text{IRQ2}}$.
3. Controls the ADC multiplexer select lines.
4. Enables $\overline{\text{PWMTRIP}}$ and PWMSYNC interrupts.
5. Controls the multiplexing of the SPORT1 pins to select either DR1A or DR1B data receive pins. It also allows configuration of SPORT1 as a UART interface.

6. Controls the PWM single/double update mode.
7. Controls the ADC conversion time modes.
8. Controls the AUXPWM mode.
9. Contains a status register (SYSSTAT) that indicates the state of the $\overline{\text{PWMTRIP}}$, $\overline{\text{PWMPOL}}$ and $\overline{\text{PWMSR}}$ pins, the watchdog timer and the PWM timer.
10. Performs a reset of the motor control peripherals and control registers following a hardware, software or watchdog initiated reset.

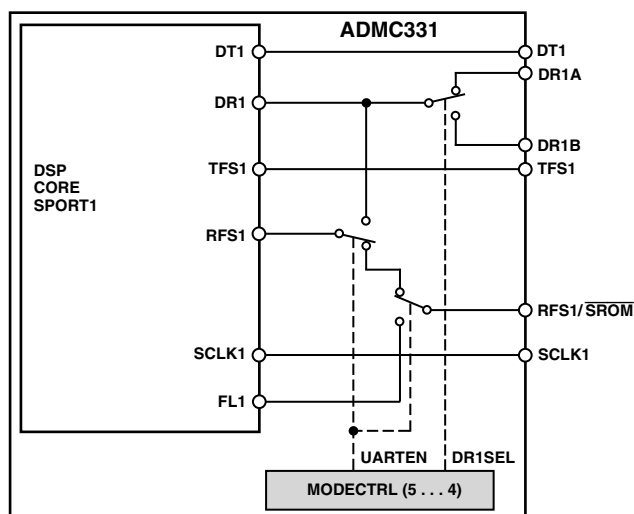

Figure 15. Internal Multiplexing of SPORT1 Pins

SPORT1 Control

The ADMC331 uses SPORT1 as the default serial port for boot loading and as the interface to the development environment. There are two data receive pins, DR1A and DR1B, on the ADMC331. This permits DR1A to be used as the data receive pin when interfacing to serial ROM or E²PROM for boot loading. Alternatively, if connecting through another external device for either boot loading or interface to the development environment, the DR1B pin can be used. Both data receive pins are multiplexed internally into the single data receive input of SPORT1. Two control bits in the MODECTRL register control the state of the SPORT1 pins by manipulating internal multiplexers in the ADMC331. The configuration of SPORT1 is illustrated in Figure 15.

Bit 4 of the MODECTRL register (DR1SEL) selects between the two data receive pins. Setting Bit 4 of MODECTRL connects the DR1B pin to the internal data receive port DR1 of SPORT1. Clearing Bit 4 connects DR1A to DR1.

Setting Bit 5 of the MODECTRL register (UARTEN) configures the serial port for UART mode. In this mode, the DR1 and RFS1 pins of the internal serial port are connected together. Additionally, setting the UARTEN bit connects the FL1 flag of the DSP to the external $\overline{\text{RFS1/SROM}}$ pin. In this mode, this pin is intended to be used to reset the external serial ROM device.

The monitor code in ROM automatically configures the SPORT1 pins during the boot sequence. Initially, the DR1SEL bit is cleared and the UARTEN bit is set so that the ADMC331 first attempts to perform a reset of the external memory device using

the $\overline{\text{RFS1/SROM}}$ pin. This is accomplished by toggling the FL1 flag using the following code segment:

```
SROMRESET: SET FL1;
            TOGGLE FL1;
            TOGGLE FL1;
            RTS;
```

If successful, data will be clocked from the external device in a continuous stream. The start of the data stream is detected by the serial port on the RFS1 pin, which is connected internally to the DR1 pin in this mode. If the serial load is successful, code is downloaded and execution begins at the start of user program memory (address 0x0030). Following a SROM/E²PROM boot load, SPORT1 could be configured for normal synchronous serial mode by setting the DR1SEL pin to select the DR1B data receive pin and by clearing the UARTEN bit to return to SPORT mode.

Failing a SROM/E²PROM boot load, the ADMC331 monitor automatically sets the DR1SEL bit to select the DR1B pin and remains in UARTEN mode. The monitor code then waits for a header byte that tells it with which of the other interfaces it is to communicate. Obviously, if a debugger interface is required on SPORT1, it is not possible to use SPORT1 as a general purpose synchronous serial port. If such a serial port is required, it is recommended that SPORT0 be used.

Flag Pins

The ADMC331 provides flag pins. The alternate configuration of SPORT1 includes a Flag In (FI) and Flag Out (FO) pin. This alternate configuration of SPORT1 is selected by Bit 10 of the DSP system control register, SYSCNTL at data memory address, 0x3FFF. In the alternate configuration, the DR1 pin (either DR1A or DR1B depending on the state of the DR1SEL bit) becomes the FI pin and the DT1 pin becomes the FO pin. Additionally, RFS1 is configured as the $\overline{\text{IRQ0}}$ interrupt input and TFS1 is configured as the $\overline{\text{IRQ1}}$ interrupt. The serial port clock, SCLK1, is still available in the alternate configuration. Following boot loading from a serial memory device, it is possible to reconfigure the SPORT1 to this alternate configuration. However, if a debugger interface is used, this configuration is not possible as the normal serial port pins are required for debugger communications.

The ADMC331 also contains two software flags, FL1 and FL2. These flags may be controlled in software and perform specific functions on the ADMC331. The FL1 pin has already been described and is used to perform a reset of the external memory device via the $\overline{\text{RFS1/SROM}}$ pin. The FL2 flag is used specifically to perform a full peripheral reset of the chip (including the watchdog timer). This is accomplished by toggling the FL2 flag in software using the following code segment:

```
PRESET: SET FL2;
        TOGGLE FL2;
        TOGGLE FL2;
        RTS;
```

ADMC331

Table X. Peripheral Register Map

Address (HEX)	Offset (Decimal)	Name	Bits Used	Function
0x2000	0	ADC1	[15 ... 4]	ADC Results for V1
0x2001	1	ADC2	[15 ... 4]	ADC Results for V2
0x2002	2	ADC3	[15 ... 4]	ADC Results for V3
0x2003	3	ADCAUX	[15 ... 4]	ADC Results for VAUX
0x2004	4	PIODIR0	[7 ... 0]	PIO0 ... 7 Pins Direction Setting
0x2005	5	PIODATA0	[7 ... 0]	PIO0 ... 7 Pins Input/Output Data
0x2006	6	PIOINTEN0	[7 ... 0]	PIO0 ... 7 Pins Interrupt Enable
0x2007	7	PIOFLAG0	[7 ... 0]	PIO0 ... 7 Pins Interrupt Status
0x2008	8	PWMTM	[15 ... 0]	PWM Period
0x2009	9	PWMDT	[9 ... 0]	PWM Deadtime
0x200A	10	PWMPD	[9 ... 0]	PWM Pulse Deletion Time
0x200B	11	PWMGATE	[9 ... 0]	PWM Gate Drive Configuration
0x200C	12	PWMCHA	[15 ... 0]	PWM Channel A Pulsewidth
0x200D	13	PWMCHB	[15 ... 0]	PWM Channel B Pulsewidth
0x200E	14	PWMCHC		PWM Channel C Pulsewidth
0x200F	15	PWMSEG	[8 ... 0]	PWM Segment Select
0x2010	16	AUXCH0	[7 ... 0]	AUX PWM Output 0
0x2011	17	AUXCH1	[7 ... 0]	AUX PWM Output 1
0x2012	18	AUXTM0	[7 ... 0]	Auxiliary PWM Frequency Value
0x2013	19	AUXTM1	[7 ... 0]	Auxiliary PWM Frequency Value/Offset
0x2014	20			Reserved
0x2015	21	MODECTRL	[8 ... 0]	System Control Register
0x2016	22	SYSSTAT	[4 ... 0]	System Status
0x2017	23	IRQFLAG	[1 ... 0]	Interrupt Status
0x2018	24	WDTIMER	[15 ... 0]	Watchdog Timer
0x2019 ... 3F	25 ... 63			Reserved
0x2040 ... 43	64 ... 67			Reserved
0x2044	68	PIODIR1	[7 ... 0]	PIO8 ... 15 Pins Direction Setting
0x2045	69	PIODATA1	[7 ... 0]	PIO8 ... 15 Pins Input/Output Data
0x2046	70	PIOINTEN1	[7 ... 0]	PIO8 ... 15 Pins Interrupt Enable
0x2047	71	PIOFLAG1	[7 ... 0]	PIO8 ... 15 Pins Interrupt Status
0x2048	72	PIODIR2	[7 ... 0]	PIO16 ... 23 Pins Direction Setting
0x2049	73	PIODATA2	[7 ... 0]	PIO16 ... 23 Pins Input/Output Data
0x204A	74	PIOINTEN2	[7 ... 0]	PIO16 ... 23 Pins Interrupt Enable
0x204B	75	PIOFLAG2	[7 ... 0]	PIO16 ... 23 Pins Interrupt Status
0x204C ... 4F	76 ... 79			Reserved
0x2050 ... 5F	80 ... 95			Reserved
0x2060	96	PWMSYNCWT	[7 ... 0]	PWMSYNC Pulsewidth
0x2061	97	PWMSWT	[0]	PWM S/W Trip Bit
0x2062 ... FF	98 ... 255			Reserved

Table XI. DSP Core Registers

Address	Name	Bits	Function
0x3FFF	SYSCNTL	[15 ... 0]	System Control Register
0x3FFE	MEMWAIT	[15 ... 0]	Memory Wait State Control Register
0x3FFD	TPERIOD	[15 ... 0]	Interval Timer Period Register
0x3FFC	TCOUNT	[15 ... 0]	Interval Timer Count Register
0x3FFB	TSCALE	[7 ... 0]	Interval Timer Scale Register
0x3FFA	SPORT0_RX_WORDS1	[15 ... 0]	SPORT0 Multichannel Word 1 Receive
0x3FF9	SPORT0_RX_WORDS0	[15 ... 0]	SPORT0 Multichannel Word 0 Receive
0x3FF8	SPORT0_TX_WORDS1	[15 ... 0]	SPORT0 Multichannel Word 1 Transmit
0x3FF7	SPORT0_TX_WORDS0	[15 ... 0]	SPORT0 Multichannel Word 0 Transmit
0x3FF6	SPORT0_CTRL_REG	[15 ... 0]	SPORT0 Control Register
0x3FF5	SPORT0_SCLKDIV	[15 ... 0]	SPORT0 Clock Divide Register
0x3FF4	SPORT0_RFSDIV	[15 ... 0]	SPORT0 Receive Frame Sync Divide
0x3FF3	SPORT0_AUTOBUF_CTRL	[15 ... 0]	SPORT0 Autobuffer Control Register
0x3FF2	SPORT1_CTRL_REG	[15 ... 0]	SPORT1 Control Register
0x3FF1	SPORT1_SCLKDIV	[15 ... 0]	SPORT1 Clock Divide Register
0x3FF0	SPORT1_RFSDIV	[15 ... 0]	SPORT1 Receive Frame Sync Divide
0x3FEF	SPORT1_AUTOBUF_CTRL	[15 ... 0]	SPORT1 Autobuffer Control Register

ADMC331

System Controller Registers

The system controller includes three registers, MODECTRL, SYSSTAT and IRQFLAG registers. The format of these registers is shown at the end of the data sheet.

The MODECTRL register controls different multiplexing, PWM interrupt and operating modes:

- Bit 0 and 1 control the multiplexing of the ADC auxiliary channels.
- Bit 2 enables/disables the $\overline{\text{PWMTRIP}}$ interrupt: if the bit is set the interrupt is enabled.
- Bit 3 enables/disables the PWMSYNC interrupt: if the bit is set the interrupt is enabled.
- Bit 4 controls the multiplexing of the SPORT1 pins: if the bit is set DR1B is selected.
- Bit 5 controls the configuration of SPORT1 as a UART interface: if the bit is set UART mode is enabled.
- Bit 6 selected the PWM operating mode: single or double duty cycle update modes. If the bit is set double update mode is selected.
- Bit 7 selects the ADC counter frequency: if the bit is set full DSP clkout frequency is selected.
- Bit 8 selects the Auxiliary PWM operating mode: offset or independent modes: if the bit is set independent mode is selected.

The SYSSTAT register displays various status information:

- Bit 0 indicates the status of the $\overline{\text{PWMTRIP}}$ pin: if this bit is high, then $\overline{\text{PWMTRIP}}$ pin is high and no PWMTRIP is occurring, if this bit is low, then the PWM is currently shut down.
- Bit 1 indicates the status of the watchdog flag register: this bit is set following a watchdog timeout.
- Bit 2 indicates the status of the PWMPOL pin: if this bit is set, the PWMPOL pin is high and active high PWM outputs will be produced.
- Bit 3 indicates the status of the PWM timer.
- Bit 4 indicates the status of the $\overline{\text{PWMSR}}$ pin: if this bit is set to a logic one, the $\overline{\text{PWMSR}}$ pin is low and switched reluctance mode is enabled.

The IRQFLAG register indicates the occurrence of PWM interrupts:

- Bit 0 indicates that a $\overline{\text{PWMTRIP}}$ interrupt, either hardware or software, has occurred.
- Bit 1 indicates that a PWMSYNC interrupt has occurred.

Register Memory Map

The address, name, used bits and function of all motor control peripheral registers of the ADMC331 are tabulated in Table X. In addition, the relevant DSP core registers are tabulated in Table XI. Full details of the DSP core registers can be obtained by referring to the ADSP-2171 sections of the *ADSP-2100 Family User's Manual, Third Edition*.

Development Kit

To facilitate device evaluation and programming, an evaluation kit (ADMC331-EVAL KIT) is available from Analog Devices. The evaluation kit consists of an evaluation board and the Motion Control Debugger software. The evaluation kit contains latest programming and device information. It is recommended that the evaluation kit be used for initial program development.

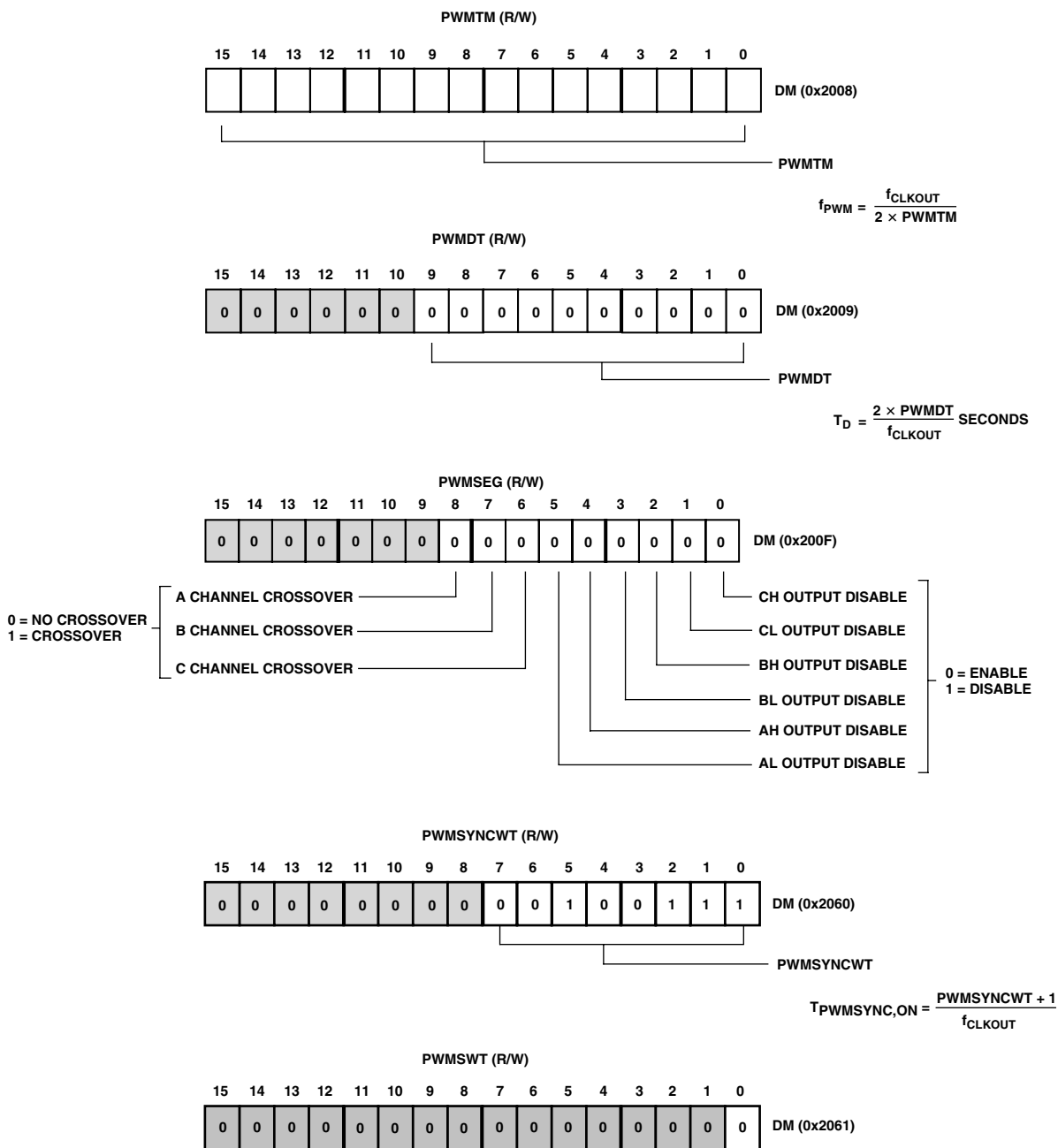

Figure 16. Configuration of ADC331 Registers

Default bit values are shown; if no value is shown, the bit field is undefined at reset. Reserved bits are shown on a gray field—these bits should always be written as shown.

ADMC331

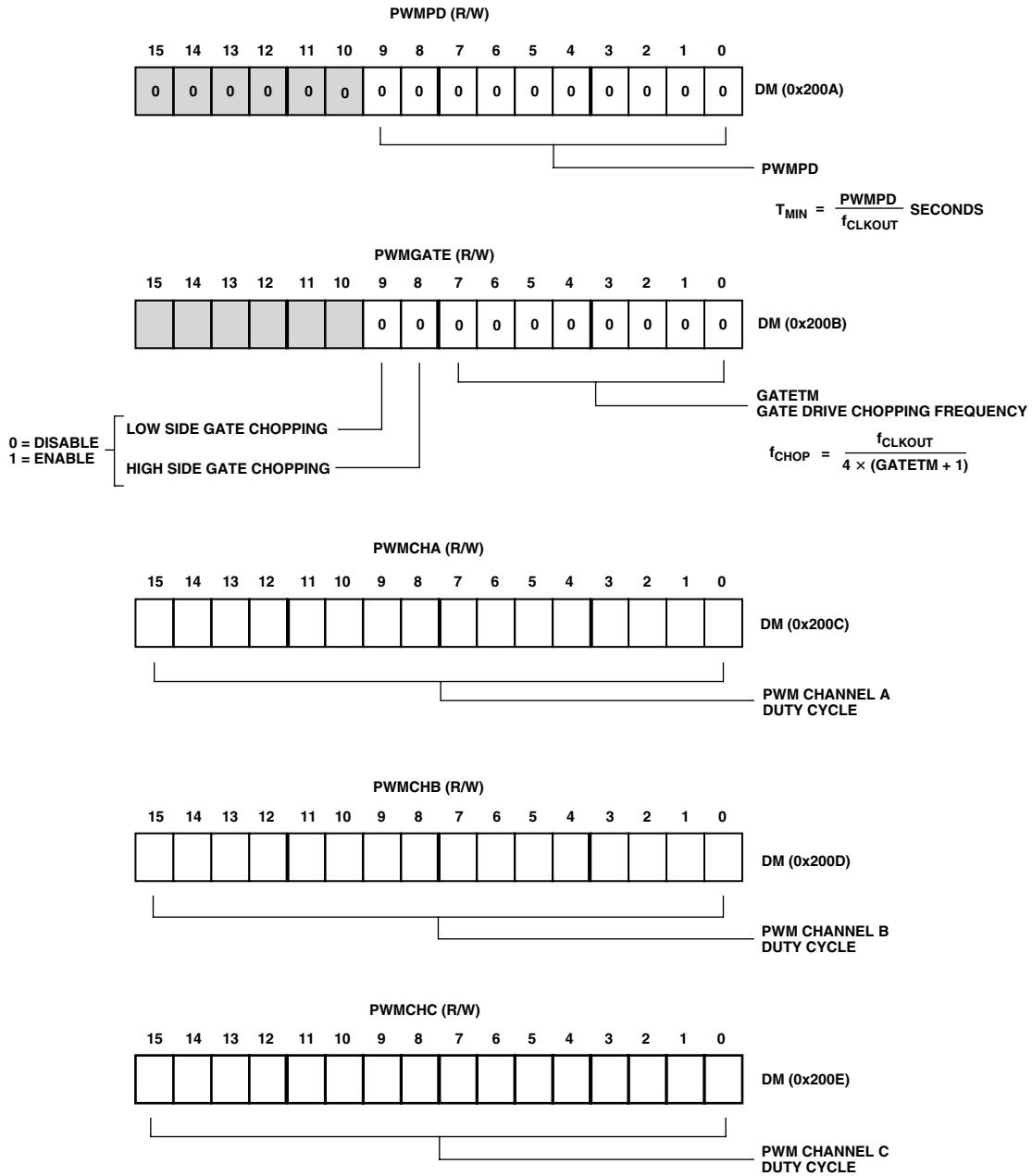

Figure 17. Configuration of ADCM331 Registers

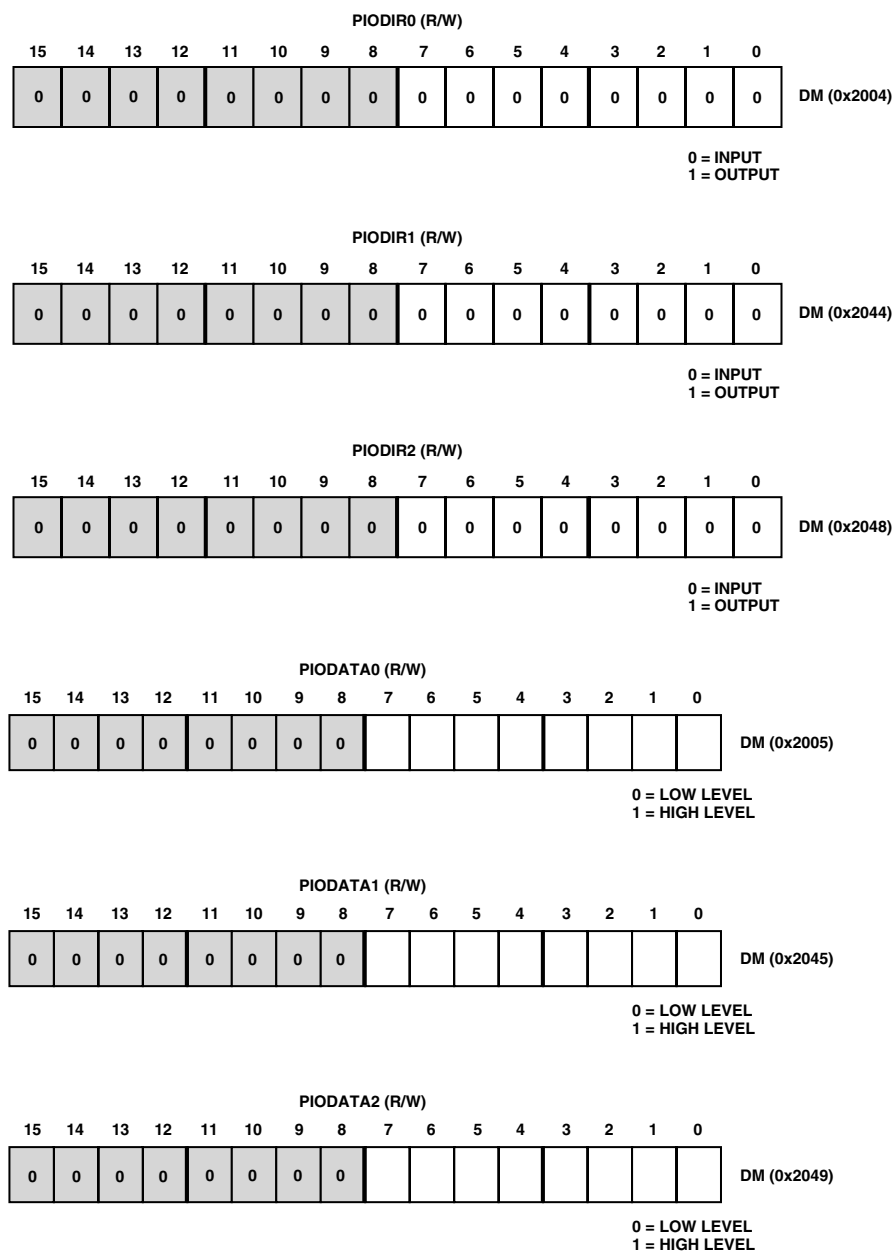
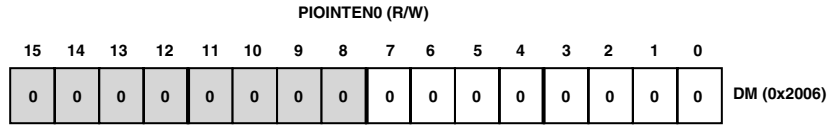

Figure 18. Configuration of ADMC331 Registers

Default bit values are shown; if no value is shown, the bit field is undefined at reset. Reserved bits are shown on a gray field—these bits should always be written as shown.

ADMC331



0 = INTERRUPT DISABLE
1 = INTERRUPT ENABLE

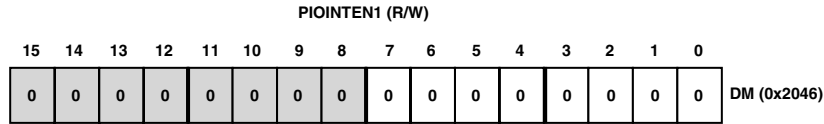

0 = INTERRUPT DISABLE
1 = INTERRUPT ENABLE

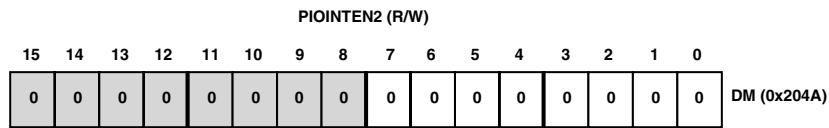

0 = INTERRUPT DISABLE
1 = INTERRUPT ENABLE

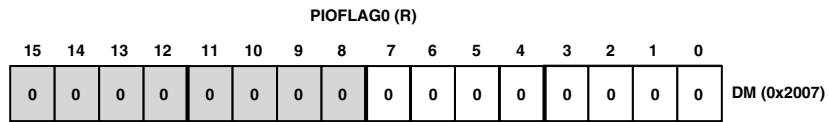

0 = NO INTERRUPT
1 = INTERRUPT FLAGGED

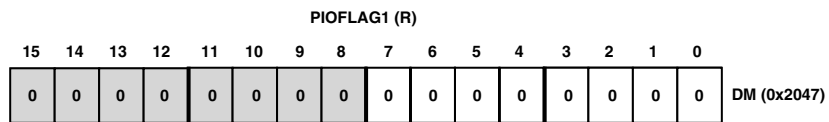

0 = NO INTERRUPT
1 = INTERRUPT FLAGGED

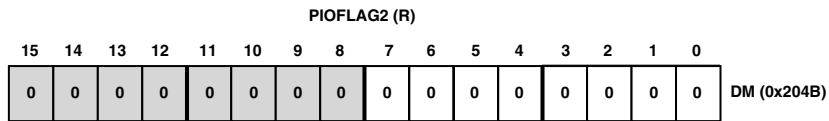

0 = NO INTERRUPT
1 = INTERRUPT FLAGGED

Figure 19. Configuration of ADCM331 Registers

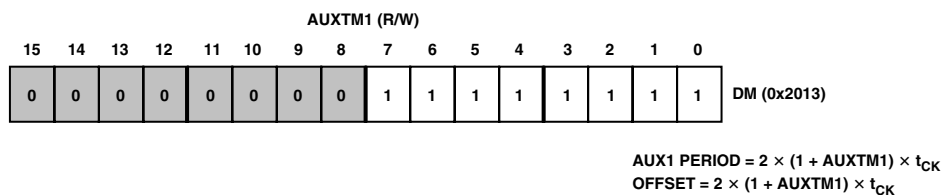
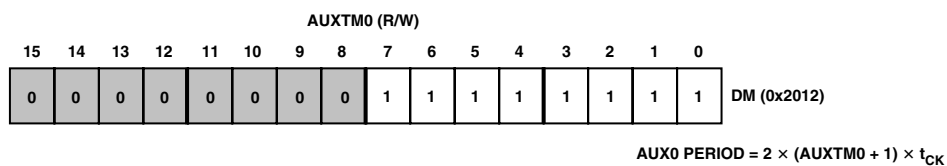
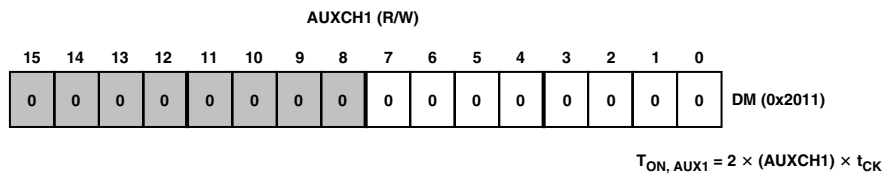
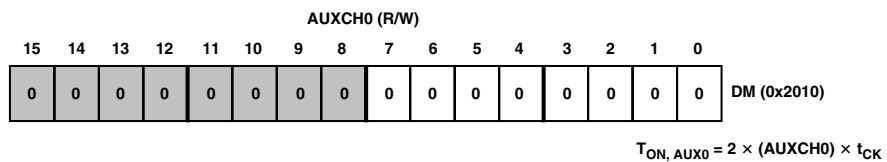

Figure 20. Configuration of ADCM331 Registers

Default bit values are shown; if no value is shown, the bit field is undefined at reset. Reserved bits are shown on a gray field—these bits should always be written as shown.

ADMC331

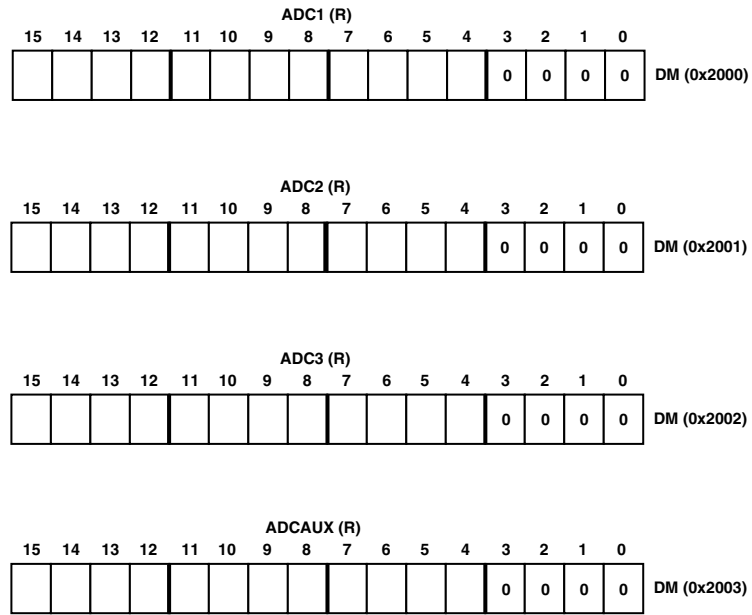

Figure 21. Configuration of ADCM331 Registers

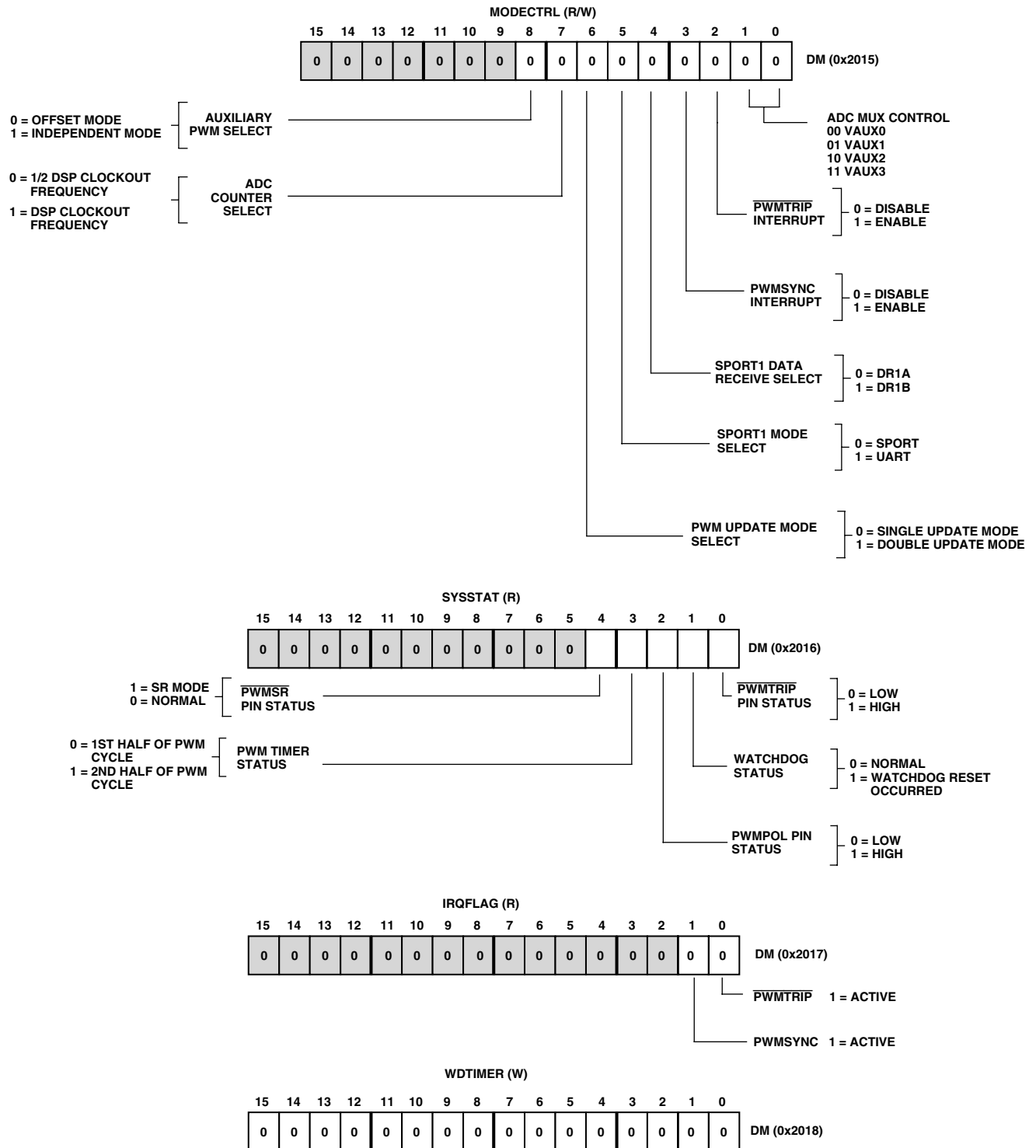

Figure 22. Configuration of ADCM331 Registers

Default bit values are shown; if no value is shown, the bit field is undefined at reset. Reserved bits are shown on a gray field—these bits should always be written as shown.

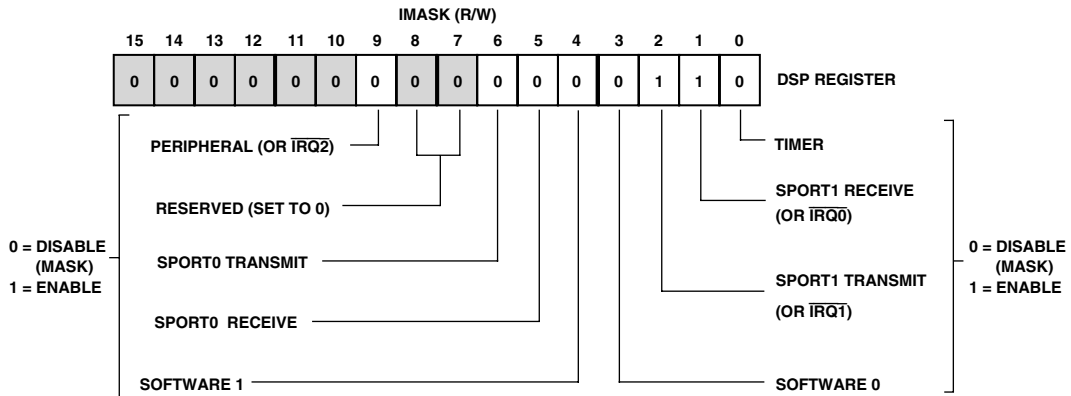
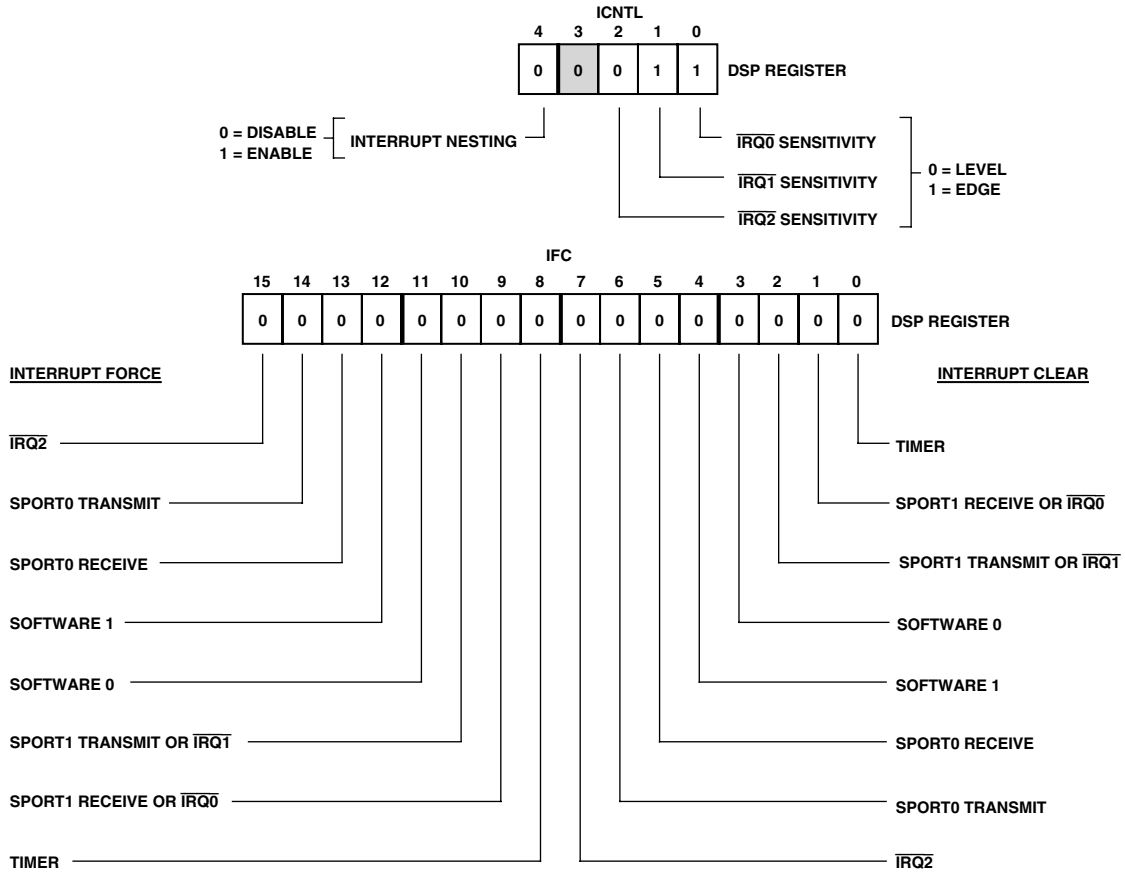

Figure 23. Configuration of ADCM331 Registers

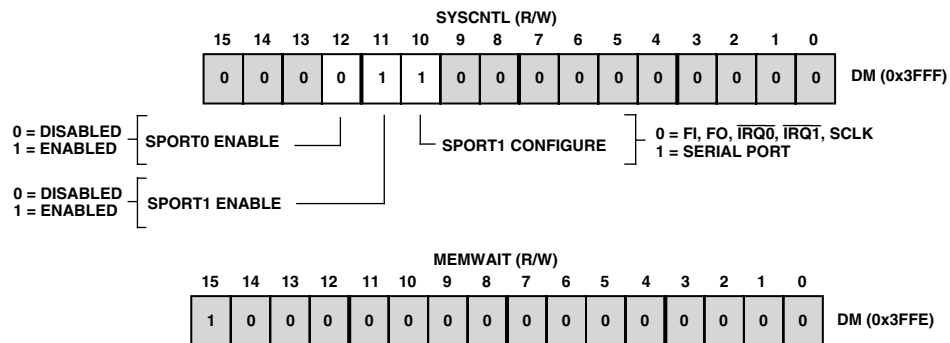
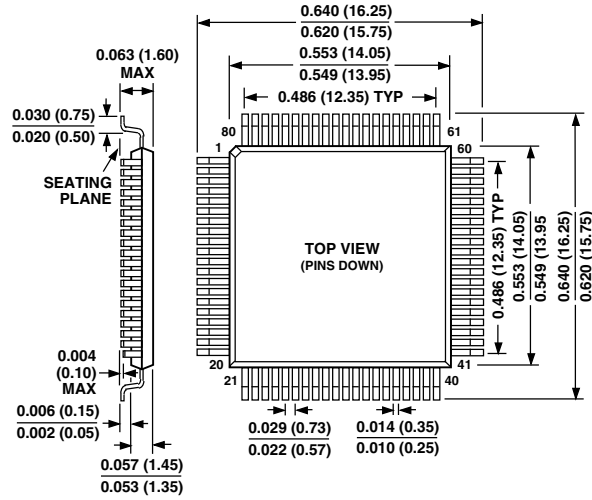

Figure 24. Configuration of ADCM331 Registers

OUTLINE DIMENSIONS

Dimensions shown in inches and (mm).

**80-Lead Plastic Thin Quad Flatpack (TQFP)
(ST-80)**





LittleDiode supplies new, hard to find or obsolete electronic components and semiconductors all over the world.

With over two million different components listed you are sure to find the part you need.

Feel free to visit us today at our online store:

LittleDiode.com

Looking forward to providing you with the best possible service.