

ADN2819—SPECIFICATIONS ($T_A = T_{MIN}$ to T_{MAX} , $V_{CC} = V_{MIN}$ to V_{MAX} , $V_{EE} = 0$ V, $C_F = 4.7$ μ F, $SLICEP = SLICEN = V_{CC}$, unless otherwise noted.)

Parameter	Conditions	Min	Typ	Max	Unit
QUANTIZER—DC CHARACTERISTICS					
Input Voltage Range	@ PIN or NIN, DC-Coupled	0		1.2	V
Peak-to-Peak Differential Input				2.4	V
Input Common-Mode Level	DC-Coupled (See Figure 26)	0.4			V
Differential Input Sensitivity	PIN-NIN, AC-Coupled ¹ , BER = 1×10^{-10}		4	10	mV p-p
Input Overdrive	See Figure 6		2	5	mV p-p
Input Offset			500		μ V
Input rms Noise	BER = 1×10^{-10}		244		μ V rms
QUANTIZER—AC CHARACTERISTICS					
Upper -3 dB Bandwidth			1.9		GHz
Small Signal Gain	Differential		54		dB
S11	@ 2.5 GHz		-15		dB
Input Resistance	Differential		100		Ω
Input Capacitance			0.65		pF
Pulsewidth Distortion ²			10		ps
QUANTIZER SLICE ADJUSTMENT					
Gain	SliceP-SliceN = ± 0.5 V	0.11	0.20	0.30	V/V
Control Voltage Range	SliceP-SliceN	-0.8		+0.8	V
Control Voltage Range	@ SliceP or SliceN	1.3		VCC	V
Slice Threshold Offset			± 1.0		mV
LEVEL SIGNAL DETECT (SDOUT)					
Level Detect Range (See Figure 2)	$R_{THRESH} = 2 \Omega$	9.4	13.3	18.0	mV
	$R_{THRESH} = 20 \text{ k}\Omega$	2.5	5.3	7.6	mV
	$R_{THRESH} = 90 \text{ k}\Omega$	0.7	3.0	5.2	mV
Response Time	DC-Coupled	0.1	0.3	5	μ s
Hysteresis (Electrical)	OC-48, PRBS 2 ²³				
	$R_{THRESH} = 2 \text{ k}\Omega$	5.6	6.6	7.8	dB
	$R_{THRESH} = 20 \text{ k}\Omega$	3.9	6.2	8.5	dB
	$R_{THRESH} = 90 \text{ k}\Omega$	3.2	6.7	9.9	dB
	OC-12, PRBS 2 ²³				
	$R_{THRESH} = 2 \text{ k}\Omega$	4.7	6.4	7.8	dB
	$R_{THRESH} = 20 \text{ k}\Omega$	1.8	6.0	10.0	dB
	$R_{THRESH} = 90 \text{ k}\Omega$		6.3		dB
	$R_{THRESH} = 90 \text{ k}\Omega$ @ 25°C	4.8	6.9	8.9	dB
	OC-3, PRBS 2 ²³				
	$R_{THRESH} = 2 \text{ k}\Omega$	3.6	6.2	8.5	dB
	$R_{THRESH} = 20 \text{ k}\Omega$		5.6		dB
	$R_{THRESH} = 90 \text{ k}\Omega$		5.6		dB
	$R_{THRESH} = 90 \text{ k}\Omega$ @ 25°C	3.4	6.6	9.9	dB
	OC-48, PRBS 2 ⁷				
	$R_{THRESH} = 2 \text{ k}\Omega$	5.6	6.6	7.8	dB
	$R_{THRESH} = 20 \text{ k}\Omega$	3.9	6.2	8.5	dB
	$R_{THRESH} = 90 \text{ k}\Omega$	3.2	6.7	9.9	dB
	OC-12, PRBS 2 ⁷				
	$R_{THRESH} = 2 \text{ k}\Omega$	5.7	6.6	7.8	dB
	$R_{THRESH} = 20 \text{ k}\Omega$	3.9	6.2	8.5	dB
	$R_{THRESH} = 90 \text{ k}\Omega$	3.2	6.7	9.9	dB
	OC-3, PRBS 2 ⁷				
	$R_{THRESH} = 2 \text{ k}\Omega$	5.4	6.6	7.7	dB
	$R_{THRESH} = 20 \text{ k}\Omega$	4.6	6.4	8.2	dB
	$R_{THRESH} = 90 \text{ k}\Omega$	3.9	6.8	9.7	dB
LOSS OF LOCK DETECTOR (LOL)					
Loss of Lock Response Time	From f_{VCO} Error > 1000 ppm		60		mV
POWER SUPPLY VOLTAGE					
		3.0	3.3	3.6	V
POWER SUPPLY CURRENT					
		150	164	215	mA

Parameter	Conditions	Min	Typ	Max	Unit	
PHASE-LOCKED LOOP CHARACTERISTICS						
Jitter Transfer BW	PIN–NIN = 10 mV p-p					
	OC-48		590	880	kHz	
Jitter Peaking	GbE		310	480	kHz	
	OC-12		140	200	kHz	
	OC-3		48	85	kHz	
	OC-48		0.025		dB	
Jitter Generation	OC-12		0.004		dB	
	OC-3		0.002		dB	
	OC-48, 12 kHz–20 MHz			0.003	UI rms	
			0.05	0.09	UI p-p	
Jitter Tolerance	OC-12, 12 kHz–5 MHz			0.002	UI rms	
			0.02	0.04	UI p-p	
	OC-3, 12 kHz–1.3 MHz			0.002	UI rms	
			0.02	0.04	UI p-p	
	OC-48 (See Figure 12)					
	600 Hz ³	92			UI p-p	
	6 kHz ³	20			UI p-p	
	100 kHz	5.5			UI p-p	
	1 MHz ³	1.0			UI p-p	
	GbE (OC-24) (See Figure 12)					
	300 Hz ³	16			UI p-p	
	3 kHz ³	16			UI p-p	
50 kHz	7.7			UI p-p		
500 kHz ³	2.2			UI p-p		
OC-12 (See Figure 12)						
30 Hz ³	100			UI p-p		
300 Hz	44			UI p-p		
25 kHz	5.8			UI p-p		
250 kHz ³	1.0			UI p-p		
OC-3 (See Figure 12)						
30 Hz ³	50			UI p-p		
300 Hz ³	23.5			UI p-p		
6500 kHz	6.0			UI p-p		
65 kHz ³	1.0			UI p-p		
CML OUTPUTS (CLKOUTP/N, DATAOUTP/N)						
Single-Ended Output Swing	V _{SE} (See Figure 5)	300	455	600	mV	
Differential Output Swing	V _{DIFF} (See Figure 5)	600	910	1200	mV	
Output High Voltage	V _{OH}		VCC		V	
Output Low Voltage	V _{OL} , referred to VCC	–0.60		–0.30	V	
Rise Time	20%–80%			150	ps	
Fall Time	80%–20%			150	ps	
Setup Time	T _S (See Figure 1)					
	OC-48	140			ps	
	GbE	350			ps	
	OC-12	750			ps	
	OC-3	3145			ps	
	Hold Time	T _H (See Figure 1)				
		OC-48	150			ps
		GbE	350			ps
OC-12		750			ps	
	OC-3	3150			ps	
REFCLK DC INPUT CHARACTERISTICS						
Input Voltage Range	@ REFCLKP or REFCLKN	0		VCC	V	
Peak-to-Peak Differential Input		100			mV	
Common-Mode Level	DC-Coupled, Single-Ended		VCC/2		V	

ADN2819

SPECIFICATIONS (continued)

Parameter	Conditions	Min	Typ	Max	Unit
TEST DATA DC INPUT CHARACTERISTICS ⁴ (TDINP/N) Peak-to-Peak Differential Input Voltage	CML Inputs		0.8		V
LVTTL DC INPUT CHARACTERISTICS					
Input High Voltage	V_{IH}	2.0			V
Input Low Voltage	V_{IL}			0.8	V
Input Current	$V_{IN} = 0.4\text{ V}$ or $V_{IN} = 2.4\text{ V}$	-5		+5	μA
Input Current (SEL0 and SEL1 only) ⁵	$V_{IN} = 0.4\text{ V}$ or $V_{IN} = 2.4\text{ V}$	-5		+50	μA
LVTTL DC OUTPUT CHARACTERISTICS					
Output High Voltage	$V_{OH}, I_{OH} = -2.0\text{ mA}$	2.4			V
Output Low Voltage	$V_{OL}, I_{OL} = +2.0\text{ mA}$			0.4	V

NOTES

¹PIN and NIN should be differentially driven, ac-coupled for optimum sensitivity.

²PWD measurement made on quantizer outputs in BYPASS mode.

³Jitter tolerance measurements are equipment limited.

⁴TDINP/N are CML inputs. If the drivers to the TDINP/N inputs are anything other than CML, they must be ac-coupled.

⁵SEL0 and SEL1 have internal pull-down resistors causing higher I_{IH} .

Specifications subject to change without notice.

ABSOLUTE MAXIMUM RATINGS*

Supply Voltage (VCC)	5.5 V
Minimum Input Voltage (All Inputs)	$VEE - 0.4\text{ V}$
Maximum Input Voltage (All Inputs)	$VCC + 0.4\text{ V}$
Maximum Junction Temperature	165°C
Storage Temperature	-65°C to +150°C
Lead Temperature (Soldering 10 sec)	300°C

*Stresses above those listed under Absolute Maximum Ratings may cause permanent damage to the device. This is a stress rating only; functional operation of the device at these or any other conditions above those indicated in the operational section of this specification is not implied. Exposure to absolute maximum rating conditions for extended periods may affect device reliability.

THERMAL CHARACTERISTICS

Thermal Resistance

48-Lead LFCSP, four-layer board with exposed paddle soldered to VCC

$\theta_{JA} = 25^\circ\text{C/W}$

ORDERING GUIDE

Model	Temperature Range	Package	Option
ADN2819ACP-CML	-40°C to +85°C	48-Lead LFCSP	CP-48
ADN2819ACP-CML-RL	-40°C to +85°C	48-Lead LFCSP	CP-48

CAUTION

ESD (electrostatic discharge) sensitive device. Electrostatic charges as high as 4000 V readily accumulate on the human body and test equipment and can discharge without detection. Although the ADN2819 features proprietary ESD protection circuitry, permanent damage may occur on devices subjected to high energy electrostatic discharges. Therefore, proper ESD precautions are recommended to avoid performance degradation or loss of functionality.



PIN CONFIGURATION

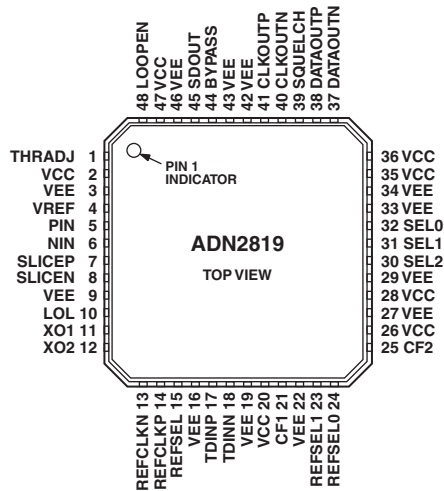

PIN FUNCTION DESCRIPTION

Pin Number	Mnemonic	Type	Description
1	THRADJ	AI	LOS Threshold Setting Resistor
2, 26, 28, Pad	VCC	P	Analog Supply
3, 9, 16, 19, 22, 27, 29, 33, 34, 42, 43, 46	VEE	P	Ground
4	VREF	AO	Internal VREF Voltage. Decouple to GND with 0.1 μ F capacitor.
5	PIN	AI	Differential Data Input
6	NIN	AI	Differential Data Input
7	SLICEP	AI	Differential Slice Level Adjust Input
8	SLICEN	AI	Differential Slice Level Adjust Input
10	LOL	DO	Loss of Lock Indicator. LVTTL active high.
11	XO1	AO	Crystal Oscillator
12	XO2	AO	Crystal Oscillator
13	REFCLKN	DI	Differential REFCLK Input. LVTTL, LVCMOS, LVPECL, LVDS (LVPECL, LVDS only at 155.52 MHz).
14	REFCLKP	DI	Differential REFCLK Input. LVTTL, LVCMOS, LVPECL, LVDS (LVPECL, LVDS only at 155.52 MHz).
15	REFSEL	DI	Reference Source Select. "0" = on-chip oscillator with external crystal; "1" = external clock source, LVTTL.
17	TDINP	AI	Differential Test Data Input. CML.
18	TDINN	AI	Differential Test Data Input. CML.
20, 47	VCC	P	Digital Supply
21	CF1	AO	Frequency Loop Capacitor
23	REFSEL1	DI	Reference Frequency Select (See Table III) LVTTL.
24	REFSEL0	DI	Reference Frequency Select (See Table III) LVTTL.
25	CF2	AO	Frequency Loop Capacitor
30	SEL2	DI	Data Rate Select (See Table II) LVTTL.
31	SEL1	DI	Data Rate Select (See Table II) LVTTL.
32	SEL0	DI	Data Rate Select (See Table II) LVTTL.
35, 36	VCC	P	Output Driver Supply
37	DATAOUTN	DO	Differential Retimed Data Output. CML.
38	DATAOUTP	DO	Differential Retimed Data Output. CML.
39	SQUELCH	DI	Disable Clock and Data Outputs. Active high. LVTTL.
40	CLKOUTN	DO	Differential Recovered Clock Output. CML.
41	CLKOUTP	DO	Differential Recovered Clock Output. CML.
44	BYPASS	DI	Bypass CDR Mode. Active high. LVTTL.
45	SDOUT	DO	Loss of Signal Detect Output. Active high. LVTTL.
48	LOOPEN	DI	Enable Test Data Inputs. Active high. LVTTL.

Type: P = Power, AI = Analog Input, AO = Analog Output, DI = Digital Input, DO = Digital Output

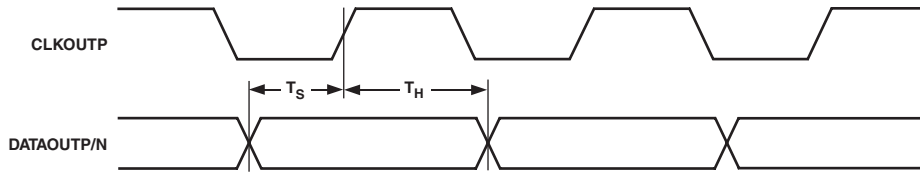

Figure 1. Output Timing

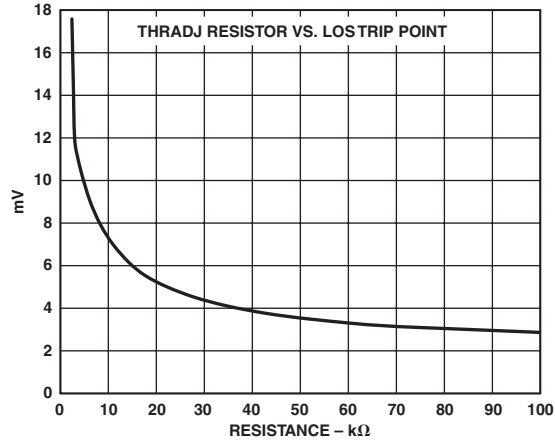

Figure 2. LOS Comparator Trip Point Programming

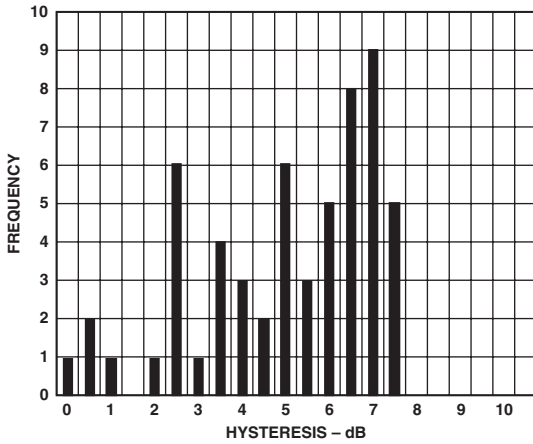

Figure 3. LOS Hysteresis OC-3, -40°C , 3.6 V, $2^{23}-1$ PRBS Input Pattern, $R_{TH} = 90\text{ k}\Omega$

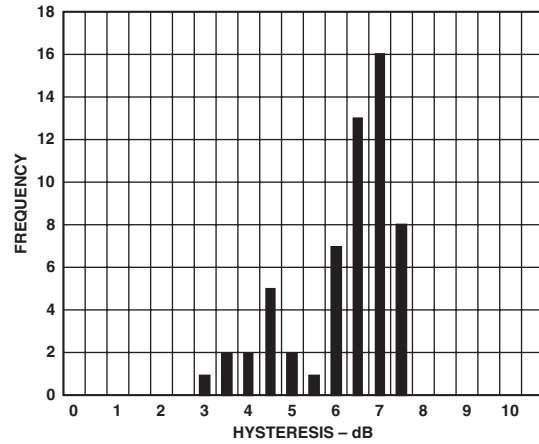

Figure 4. LOS Hysteresis OC-12, -40°C , 3.6 V, $2^{23}-1$ PRBS Input Pattern, $R_{TH} = 90\text{ k}\Omega$

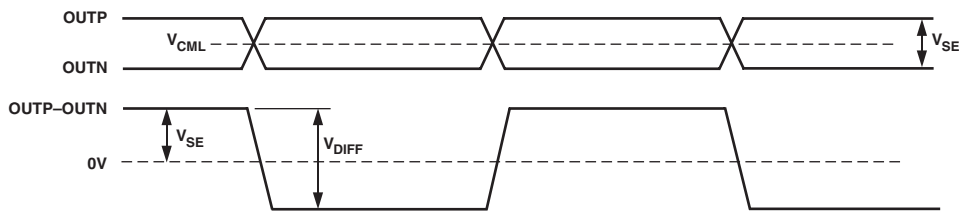

Figure 5. Single-Ended vs. Differential Output Specifications

DEFINITION OF TERMS

Maximum, Minimum, and Typical Specifications

Specifications for every parameter are derived from statistical analyses of data taken on multiple devices from multiple wafer lots. Typical specifications are the mean of the distribution of the data for that parameter. If a parameter has a maximum (or a minimum), that value is calculated by adding to (or subtracting from) the mean six times the standard deviation of the distribution. This procedure is intended to tolerate production variations. If the mean shifts by 1.5 standard deviations, the remaining 4.5 standard deviations still provide a failure rate of only 3.4 parts per million. For all tested parameters, the test limits are guardbanded to account for tester variation to thus guarantee that no device is shipped outside of data sheet specifications.

INPUT SENSITIVITY AND INPUT OVERDRIVE

Sensitivity and overdrive specifications for the quantizer involve offset voltage, gain, and noise. The relationship between the logic output of the quantizer and the analog voltage input is shown in Figure 6. For sufficiently large positive input voltage, the output is always Logic 1; similarly for negative inputs, the output is always Logic 0. However, the transitions between output Logic Levels 1 and 0 are not at precisely defined input voltage levels but occur over a range of input voltages. Within this zone of confusion, the output may be either 1 or 0, or it may even fail to attain a valid logic state. The width of this zone is determined by the input voltage noise of the quantizer. The center of the zone of confusion is the quantizer input offset voltage. Input overdrive is the magnitude of signal required to guarantee the correct logic level with 1×10^{-10} confidence level.

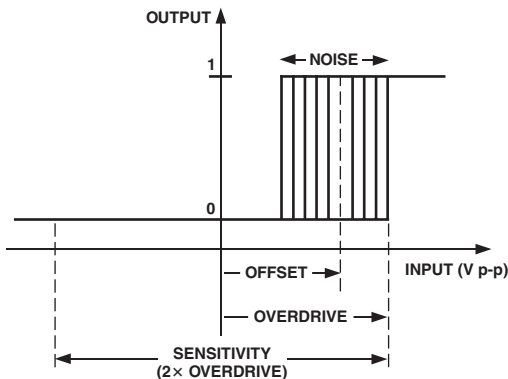

Figure 6. Input Sensitivity and Input Overdrive

SINGLE-ENDED VS. DIFFERENTIAL

AC-coupling is typically used to drive the inputs to the quantizer. The inputs are internally dc biased to a common-mode potential of ~ 0.6 V. Driving the ADN2819 single-ended and observing the quantizer input with an oscilloscope probe at the point indicated in Figure 7 shows a binary signal with average value equal to the common-mode potential and instantaneous values both above and below the average value. It is convenient to measure the peak-to-peak amplitude of this signal and call the minimum required value the quantizer sensitivity. Referring to Figure 6, since both positive and negative offsets need to be accommodated, the sensitivity is twice the overdrive.

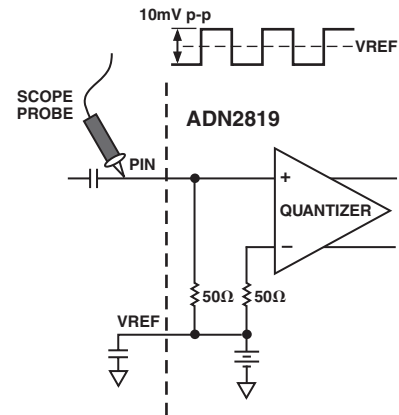

Figure 7. Single-Ended Sensitivity Measurement

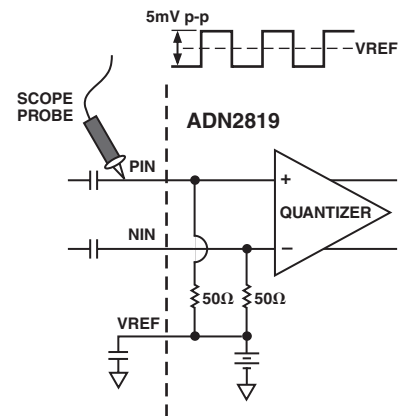

Figure 8. Differential Sensitivity Measurement

Driving the ADN2819 differentially (see Figure 8), sensitivity seems to improve by observing the quantizer input with an oscilloscope probe. This is an illusion caused by the use of a single-ended probe. A 5 mV p-p signal appears to drive the ADN2819 quantizer. However, the single-ended probe measures only half the signal. The true quantizer input signal is twice this value since the other quantizer input is a complementary signal to the signal being observed.

ADN2819

LOS RESPONSE TIME

The LOS response time is the delay between the removal of the input signal and the indication of loss of signal (LOS) at SDOOUT. The response time of the ADN2819 is 300 ns typ when the inputs are dc-coupled. In practice, the time constant of the ac-coupling at the quantizer input determines the LOS response time.

JITTER SPECIFICATIONS

The ADN2819 CDR is designed to achieve the best bit-error-rate (BER) performance and has exceeded the jitter transfer, generation, and tolerance specifications proposed for SONET/SDH equipment defined in the Telcordia Technologies specification.

Jitter is the dynamic displacement of digital signal edges from their long-term average positions measured in UI (unit intervals), where 1 UI = 1 bit period. Jitter on the input data can cause dynamic phase errors on the recovered clock sampling edge. Jitter on the recovered clock causes jitter on the retimed data.

The following section briefly summarizes the specifications of the jitter generation, transfer, and tolerance in accordance with the Telcordia document (GR-253-CORE, Issue 3, September 2000) for the optical interface at the equipment level, and the ADN2819 performance with respect to those specifications.

Jitter Generation

The jitter generation specification limits the amount of jitter that can be generated by the device with no jitter and wander applied at the input. For OC-48 devices, the band-pass filter has a 12 kHz high-pass cutoff frequency with a roll-off of 20 dB/decade and a low-pass cutoff frequency of at least 20 MHz. The jitter generated should be less than 0.01 UI rms and be less than 0.1 UI p-p.

Jitter Transfer

The jitter transfer function is the ratio of the jitter on the output signal to the jitter applied on the input signal versus the frequency. This parameter measures the limited amount of jitter on an input signal that can be transferred to the output signal (see Figure 9).

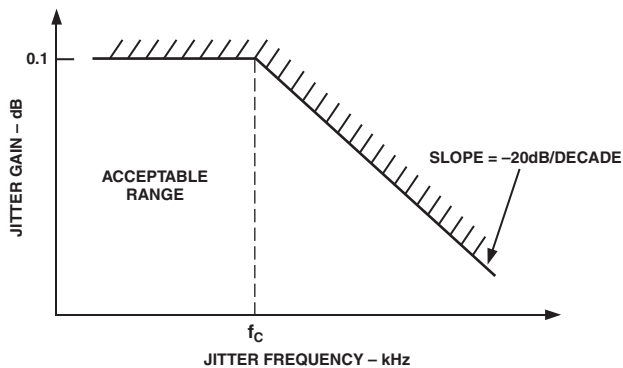

Figure 9. Jitter Transfer Curve

Jitter Tolerance

The jitter tolerance is defined as the peak-to-peak amplitude of the sinusoidal jitter applied on the input signal that causes a 1 dB power penalty. This is a stress test that is intended to ensure no additional penalty is incurred under the operating conditions (see Figure 10). Figure 11 shows the typical OC-48 jitter tolerance performance of the ADN2819.

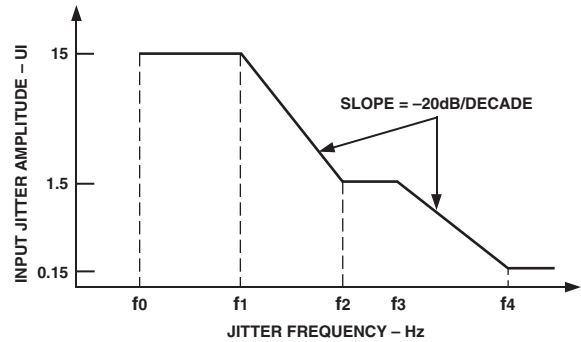

Figure 10. SONET Jitter Tolerance Mask

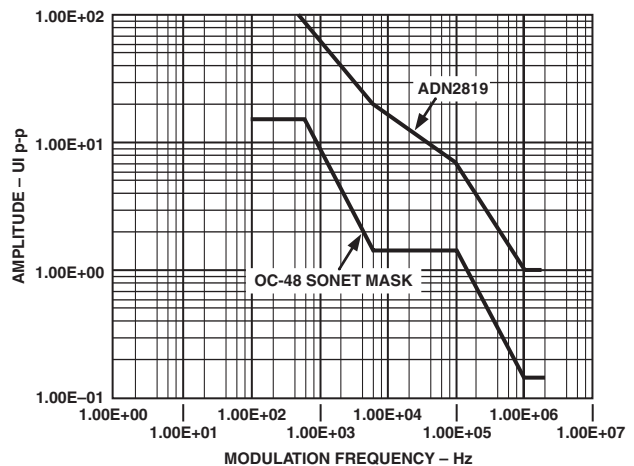

Figure 11. ADN2819 OC-48 Jitter Tolerance Curve

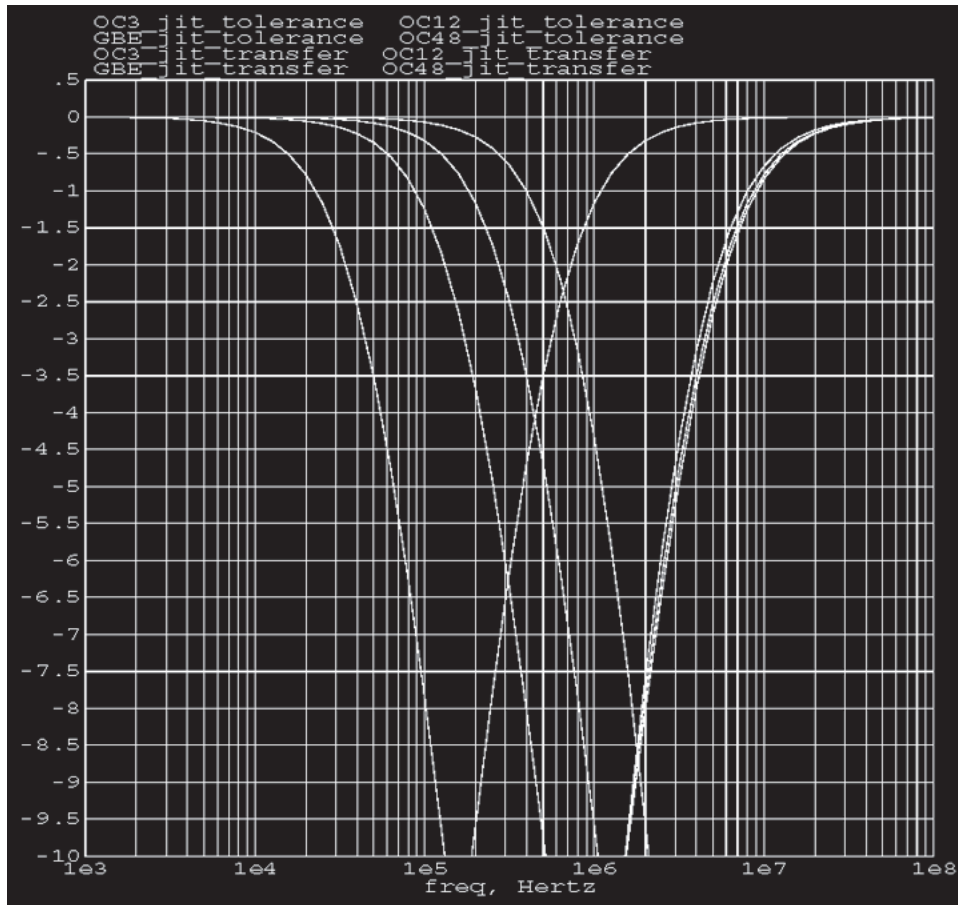

Figure 12. ADN2819 Jitter Transfer and Jitter Tracking BW

Table I. Jitter Transfer and Tolerance: SONET Spec vs. ADN2819

Rate	Jitter Transfer			Jitter Tolerance				
	SONET Spec (f_c)	ADN2819 (kHz)	Implementation Margin	Mask Corner Frequency	ADN2819	SONET Spec (UI p-p)	ADN2819 (UI p-p)	Implementation Margin*
OC-48	2 MHz	590	3.4	1 MHz	4.8 MHz	0.15	1.0	6.67
OC-12	500 kHz	140	3.6	250 kHz	4.8 MHz	0.15	1.0	6.67
OC-3	130 kHz	48	2.7	65 kHz	600 kHz	0.15	1.0	6.67

*Jitter tolerance measurements limited by test equipment capabilities.

ADN2819

THEORY OF OPERATION

The ADN2819 is a delay-locked and phase-locked loop circuit for clock recovery and data retiming from an NRZ encoded data stream. The phase of the input data signal is tracked by two separate feedback loops that share a common control voltage. A high speed delay-locked loop path uses a voltage controlled phase shifter to track the high frequency components of the input jitter. A separate phase control loop, comprised of the VCO, tracks the low frequency components of the input jitter. The initial frequency of the VCO is set by yet a third loop, which compares the VCO frequency with the reference frequency and sets the coarse tuning voltage. The jitter tracking phase-locked loop controls the VCO by the fine tuning control.

The delay and phase-locked loops together track the phase of the input data signal. For example, when the clock lags input data, the phase detector drives the VCO to a higher frequency and also increases the delay through the phase shifter. Both of these actions serve to reduce the phase error between the clock and data. The faster clock picks up phase while the delayed data loses phase. Since the loop filter is an integrator, the static phase error will be driven to zero.

Another view of the circuit is that the phase shifter implements the zero required for the frequency compensation of a second-order phase-locked loop, and this zero is placed in the feedback path and thus does not appear in the closed-loop transfer function. Jitter peaking in a conventional second-order phase-locked loop is caused by the presence of this zero in the closed-loop transfer function. Since this circuit has no zero in the closed-loop transfer, jitter peaking is minimized.

The delay-locked and phase-locked loops together simultaneously provide wideband jitter accommodation and narrow-band jitter filtering. The linearized block diagram in Figure 13 shows the jitter transfer function, $Z(s)/X(s)$, is a second-order low-pass providing excellent filtering. Note the jitter transfer has no zero, unlike an ordinary second order phase-locked loop. This means that the main PLL loop has low jitter peaking (see Figure 14), which makes this circuit ideal for signal regenerator applications where jitter peaking in a cascade of regenerators can contribute to hazardous jitter accumulation.

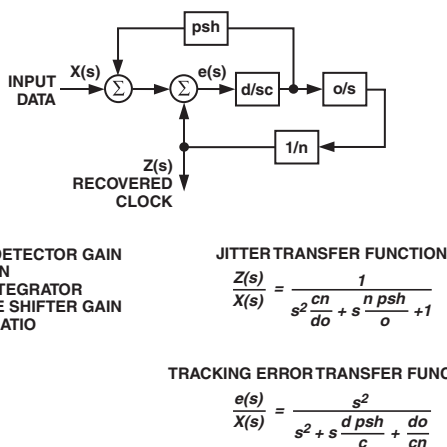

Figure 13. PLL/DLL Architecture

The error transfer, $e(s)/X(s)$, has the same high-pass form as an ordinary phase-locked loop. This transfer function is free to be optimized to give excellent wideband jitter accommodation since the jitter transfer function, $Z(s)/X(s)$, provides the narrow-band jitter filtering. See Table I for error transfer bandwidths and jitter transfer bandwidths at the various data rates.

The delay-locked and phase-locked loops contribute to overall jitter accommodation. At low frequencies of input jitter on the data signal, the integrator in the loop filter provides high gain to track large jitter amplitudes with small phase error. In this case, the VCO is frequency modulated, and jitter is tracked as in an ordinary phase-locked loop. The amount of low frequency jitter that can be tracked is a function of the VCO tuning range. A wider tuning range gives larger accommodation of low frequency jitter. The internal loop control voltage remains small for small phase errors, so the phase shifter remains close to the center of its range and thus contributes little to the low frequency jitter accommodation.

At medium jitter frequencies, the gain and tuning range of the VCO are not large enough to track the input jitter. In this case, the VCO control voltage becomes large and saturates, and the VCO frequency dwells at one or the other extreme of its tuning range. The size of the VCO tuning range therefore has only a small effect on the jitter accommodation. The delay-locked loop control voltage is now larger; therefore, the phase shifter takes on the burden of tracking the input jitter. The phase shifter range, in UI, can be seen as a broad plateau on the jitter tolerance curve. The phase shifter has a minimum range of 2 UI at all data rates.

The gain of the loop integrator is small for high jitter frequencies, so larger phase differences are needed to make the loop control voltage big enough to tune the range of the phase shifter. Large phase errors at high jitter frequencies cannot be tolerated. In this region, the gain of the integrator determines the jitter accommodation. Since the gain of the loop integrator declines linearly with frequency, jitter accommodation is lower with higher jitter frequency. At the highest frequencies, the loop gain is very small and little tuning of the phase shifter can be expected. In this case, jitter accommodation is determined by the eye opening of the input data, the static phase error, and the residual loop jitter generation. The jitter accommodation is roughly 0.5 UI in this region. The corner frequency between the declining slope and the flat region is the closed loop bandwidth of the delay-locked loop, which is roughly 5 MHz for OC-12, OC-48, and GbE data rates and 600 kHz for OC-3 data rates.

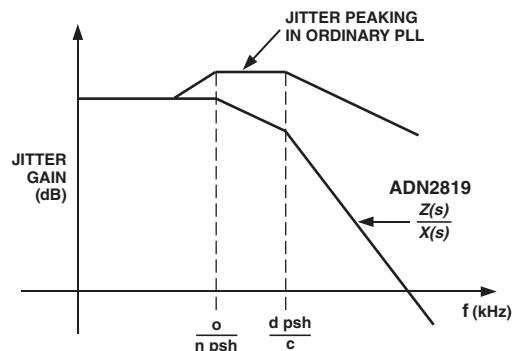

Figure 14. Jitter Response vs. Conventional PLL

FUNCTIONAL DESCRIPTION

Multirate Clock and Data Recovery

The ADN2819 will recover clock and data from serial bit streams at OC-3, OC-12, OC-48, and GbE data rates as well as the 15/14 FEC rates. The output of the 2.5 GHz VCO is divided down in order to support the lower data rates. The data rate is selected by the SEL[2..0] inputs (see Table II).

Table II. Data Rate Selection

SEL[2..0]	Rate	Frequency (MHz)
000	OC-48	2488.32
001	GbE	1250.00
010	OC-12	622.08
011	OC-3	155.52
100	OC-48 FEC	2666.06
101	GbE FEC	1339.29
110	OC-12 FEC	666.51
111	OC-3 FEC	166.63

Limiting Amplifier

The limiting amplifier has differential inputs (PIN/NIN) that are internally terminated with 50 Ω to an on-chip voltage reference (VREF = 0.6 V typically). These inputs are normally ac-coupled, although dc-coupling is possible as long as the input common-mode voltage remains above 0.4 V (see Figures 24–26 in the Applications Information section). Input offset is factory trimmed to achieve better than 4 mV typical sensitivity with minimal drift. The limiting amplifier can be driven differentially or single-ended.

Slice Adjust

The quantizer slicing level can be offset by ±100 mV to mitigate the effect of ASE (amplified spontaneous emission) noise by applying a differential voltage input of ±0.8 V to SLICEP/N inputs. If no adjustment of the slice level is needed, SLICEP/N should be tied to VCC.

Loss of Signal (LOS) Detector

The receiver front end level signal detect circuit indicates when the input signal level has fallen below a user adjustable threshold. The threshold is set with a single external resistor from Pin 1, THRADJ, to GND. The LOS comparator trip point versus the resistor value is illustrated in Figure 2 (this is only valid for SLICEP = SLICEN = VCC). If the input level to the ADN2819 drops below the programmed LOS threshold, SDOOUT (Pin 45) will indicate the loss of signal condition with a Logic 1. The LOS response time is ~300 ns by design but will be dominated by the RC time constant in ac-coupled applications.

If the LOS detector is used, the quantizer slice adjust pins must both be tied to VCC. This is to avoid interaction with the LOS threshold level.

Note that it is not expected to use both LOS and slice adjust at the same time. Systems with optical amplifiers need the slice adjust to evade ASE. However, a loss of signal in an optical link that uses optical amplifiers causes the optical amplifier output to be full-scale noise. Under this condition, the LOS would not detect the failure. In this case, the loss of lock signal will indicate the failure because the CDR circuitry will not be able to lock onto a signal that is full-scale noise.

Reference Clock

There are three options for providing the reference frequency to the ADN2819: differential clock, single-ended clock, or crystal oscillator. See Figures 15–17 for example configurations.

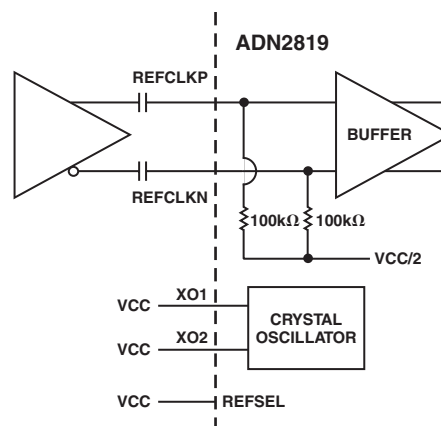

Figure 15. Differential REFCLK Configuration

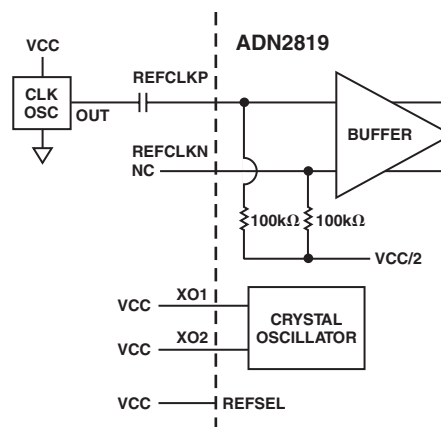

Figure 16. Single-Ended REFCLK Configuration

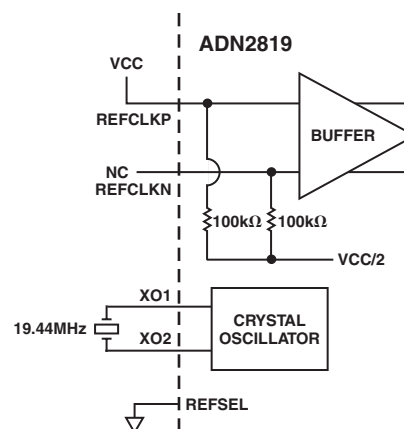

Figure 17. Crystal Oscillator Configuration

ADN2819

The ADN2819 can accept any of the following reference clock frequencies: 19.44 MHz, 38.88 MHz, 77.76 MHz at LVTTTL/LVCMOS/LVPECL/LVDS levels or 155.52 MHz at LVPECL/LVDS levels via the REFCLKN/P inputs, independent of data rate (including Gigabit Ethernet and wrapper rates). The input buffer accepts any differential signal with a peak-to-peak differential amplitude of greater than 100 mV (e.g., LVPECL or LVDS) or a standard single-ended low voltage TTL input, providing maximum system flexibility. The appropriate division ratio can be selected using the REFSEL0/1 pins, according to Table III. Phase noise and duty cycle of the reference clock are not critical and 100 ppm accuracy is sufficient.

An on-chip oscillator to be used with an external crystal is also provided as an alternative to using the REFCLKN/P inputs. Details of the recommended crystal are given in Table IV.

Table III. Reference Frequency Selection

REFSEL	REFSEL[1..0]	Applied Reference Frequency (MHz)
1	00	19.44
1	01	38.88
1	10	77.76
1	11	155.52
0	XX	REFCLKP/N Inactive. Use 19.44 MHz XTAL on Pins XO1, XO2 (pull REFCLKP to VCC)

Table IV. Required Crystal Specifications

Parameter	Value
Mode	Series Resonant
Frequency/Overall Stability	19.44 MHz \pm 100 ppm
Frequency Accuracy	\pm 100 ppm
Temperature Stability	\pm 100 ppm
Aging	\pm 100 ppm
ESR	20 Ω max

Recommended Manufacturer:
Raltron (305) 593-6033
Part Number: H10S-19.440-S-EXT

REFSEL must be tied to VCC when the REFCLKN/P inputs are active or tied to VEE when the oscillator is used. No connection between the XO pin and REFCLK input is necessary (see Figures 15-17). Note that the crystal should operate in series resonant mode, which renders it insensitive to external parasitics. No trimming capacitors are required.

Lock Detector Operation

The lock detector monitors the frequency difference between the VCO and the reference clock and deasserts the loss of lock signal when the VCO is within 500 ppm of center frequency. This enables the phase loop, which then maintains phase lock, unless the frequency error exceeds 0.1%. Should this occur, the loss of lock signal is reasserted and control returns to the frequency loop, which will reacquire and maintain a stable clock signal at the output. The frequency loop requires a single external capacitor between CF1 and CF2. The capacitor specification is given in Table V.

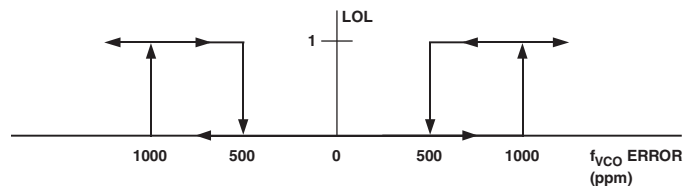

Figure 18. Transfer Function of LOL

Table V. Recommended C_F Capacitor Specification

Parameter	Value
Temperature Range	-40°C to +85°C
Capacitance	>3.0 μ F
Leakage	<80 nA
Rating	>6.3 V

Recommended Manufacturer:
Murata Electronics (770) 436-1300
Part Number: GRM32RR71C475LC01

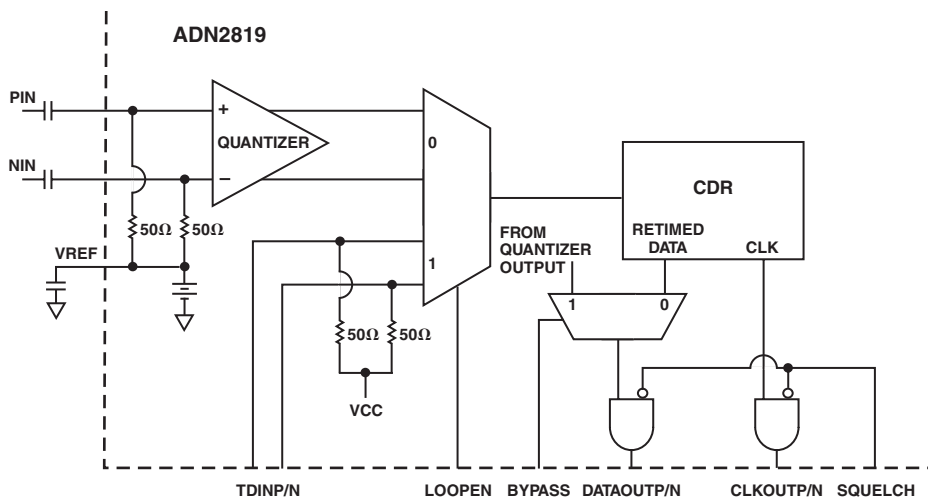

Figure 19. Test Modes

Squelch Mode

When the squelch input is driven to a TTL high state, both the clock and data outputs are set to the zero state to suppress downstream processing. If desired, this pin can be directly driven by the LOS (loss-of-signal) detector output (SDOUT). If the squelch function is not required, the pin should be tied to VEE.

Test Modes: Bypass and Loopback

When the bypass input is driven to a TTL high state, the quantizer output is connected directly to the buffers driving the data out pins, thus bypassing the clock recovery circuit (see Figure 19). This feature can help the system to deal with non-standard bit rates.

The loopback mode can be invoked by driving the LOOPEN pin to a TTL high state, which facilitates system diagnostic testing. This will connect the test inputs (TDINP/N) to the clock and data recovery circuit (per Figure 19). The test inputs have internal 50 Ω terminations and can be left floating when not in use. TDINP/N are CML inputs and can only be dc-coupled when being driven by CML outputs. The TDINP/N inputs must be ac-coupled if driven by anything other than CML outputs. Bypass and loopback modes are mutually exclusive. Only one of these modes can be used at any given time. The ADN2819 will be put into an indeterminate state if both BYPASS and LOOPEN pins are set to Logic 1 at the same time.

APPLICATIONS INFORMATION

PCB Design Guidelines

Proper RF PCB design techniques must be used for optimal performance.

Power Supply Connections and Ground Planes

Use of one low impedance ground plane to both analog and digital grounds is recommended. The VEE pins should be soldered directly to the ground plane to reduce series inductance. If the ground plane is an internal plane and connections to the ground plane are made through vias, multiple vias may be used in parallel to reduce the series inductance, especially on Pins 33 and 34, which are the ground returns for the output buffers.

Use of a 10 μF electrolytic capacitor between VCC and GND is recommended at the location where the 3.3 V supply enters the

PCB. Use of 0.1 μF and 1 nF ceramic chip capacitors should be placed between IC power supply VCC and GND as close as possible to the ADN2819 VCC pins. Again, if connections to the supply and ground are made through vias, the use of multiple vias in parallel will help to reduce series inductance, especially on Pins 35 and 36, which supply power to the high speed CLKOUTP/N and DATAOUTP/N output buffers. Refer to the schematic in Figure 20 for recommended connections.

Transmission Lines

Use of 50 Ω transmission lines are required for all high frequency input and output signals to minimize reflections, including PIN, NIN, CLKOUTP, CLKOUTN, DATAOUTP, and DATAOUTN (also REFCLKP/N for a 155.52 MHz REFCLK). It is also recommended that the PIN/NIN input traces are matched in length and that the CLKOUTP/N and DATAOUTP/N traces are matched in length. All high speed CML outputs, CLKOUTP/N and DATAOUTP/N, also require 100 Ω back termination chip resistors connected between the output pin and VCC. These resistors should be placed as close as possible to the output pins. These 100 Ω resistors are in parallel with on-chip 100 Ω termination resistors to create a 50 Ω back termination (see Figure 21).

The high speed inputs, PIN and NIN, are internally terminated with 50 Ω to an internal reference voltage (see Figure 22). A 0.1 μF capacitor is recommended between VREF, Pin 4, and GND to provide an ac ground for the inputs.

As with any high speed mixed-signal design, take care to keep all high speed digital traces away from sensitive analog nodes.

Soldering Guidelines for Chip Scale Package

The lands on the 48-lead LFCSP are rectangular. The printed circuit board pad for these should be 0.1 mm longer than the package land length and 0.05 mm wider than the package land width. The land should be centered on the pad. This will ensure that the solder joint size is maximized. The bottom of the chip scale package has a central exposed pad. The pad on the printed circuit board should be at least as large as this exposed pad. The user must connect the exposed pad to analog VCC. If vias are used, they should be incorporated into the pad at 1.2 mm pitch grid. The via diameter should be between 0.3 mm and 0.33 mm and the via barrel should be plated with 1 oz. copper to plug the via.

ADN2819

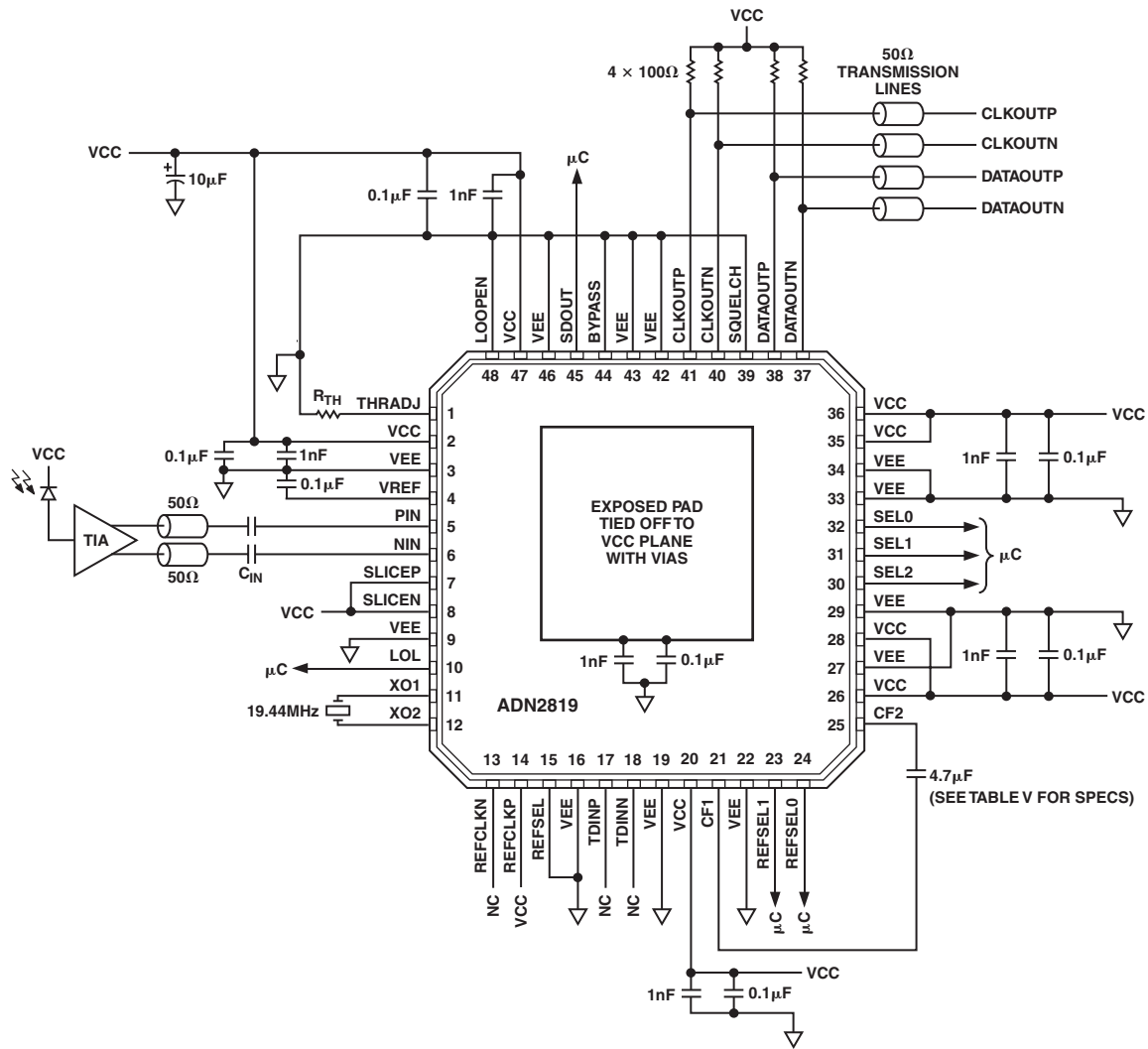

Figure 20. Typical Application Circuit

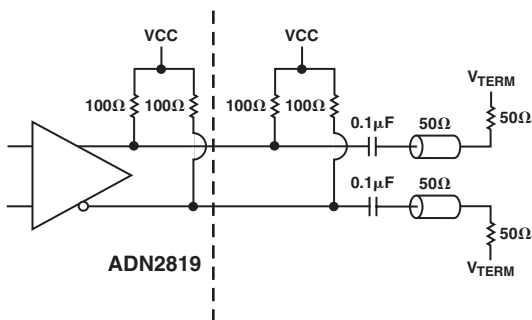

Figure 21. AC-Coupled Output Configuration

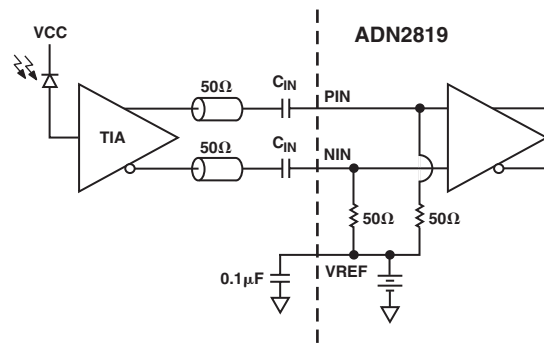
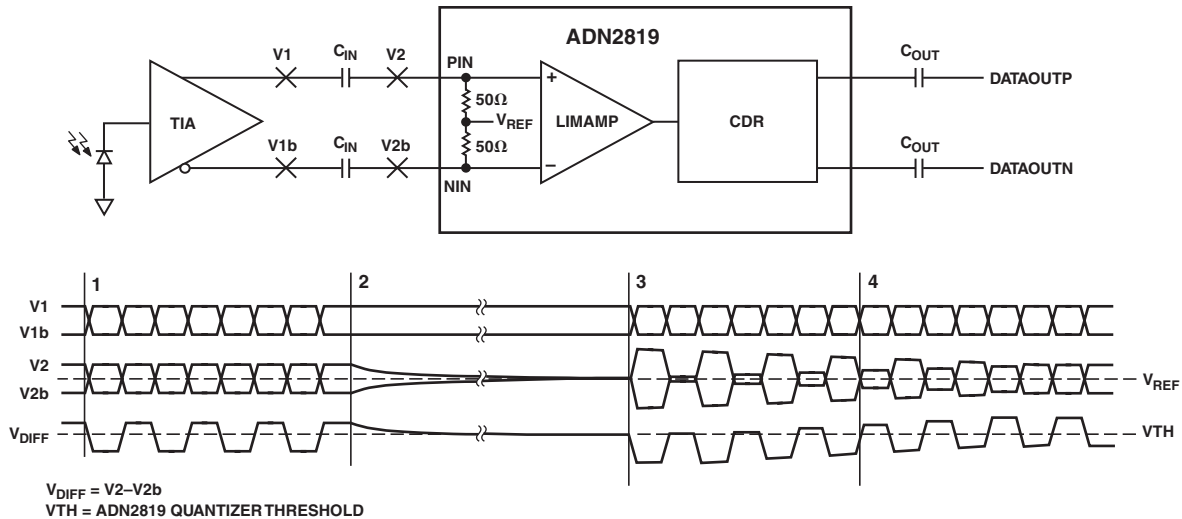

Figure 22. AC-Coupled Input Configuration

Choosing AC-Coupling Capacitors

The choice of ac-coupling capacitors at the input (PIN, NIN) and output (DATAOUTP, DATAOUTN) of the ADN2819 must be chosen such that the device works properly at the lower OC-3 and higher OC-48 data rates. When choosing the capacitors, the time constant formed with the two 50 Ω resistors in the signal path must be considered. When a large number of consecutive identical digits (CIDs) are applied, the capacitor voltage can drop due to baseline wander (see Figure 23), causing pattern dependent jitter (PDJ).

For the ADN2819 to work robustly at both OC-3 and OC-48, a minimum capacitor of 1.6 μF to PIN/NIN and 0.1 μF on DATAOUTP/DATAOUTN should be used. This is based on the assumption that 1000 CIDs must be tolerated and that the PDJ should be limited to 0.01 UI p-p.



NOTES

1. DURING DATA PATTERNS WITH HIGH TRANSITION DENSITY, DIFFERENTIAL DC VOLTAGE AT V1 AND V2 IS ZERO.
2. WHEN THE OUTPUT OF THE TIA GOES TO CID, V1 AND V1b ARE DRIVEN TO DIFFERENTIAL DC LEVELS. V2 AND V2b DISCHARGE TO THE V_{REF} LEVEL, WHICH EFFECTIVELY INTRODUCES A DIFFERENTIAL DC OFFSET ACROSS THE AC-COUPLING CAPACITORS.
3. WHEN THE BURST OF DATA STARTS AGAIN, THE DIFFERENTIAL DC OFFSET ACROSS THE AC-COUPLING CAPACITORS IS APPLIED TO THE INPUT LEVELS, CAUSING A DC SHIFT IN THE DIFFERENTIAL INPUT. THIS SHIFT IS LARGE ENOUGH SUCH THAT ONE OF THE STATES, EITHER HIGH OR LOW DEPENDING ON THE LEVELS OF V1 AND V1b WHEN THE TIA WENT TO CID, IS CANCELLED OUT. THE QUANTIZER WILL NOT RECOGNIZE THIS AS A VALID STATE.
4. THE DC OFFSET SLOWLY DISCHARGES UNTIL THE DIFFERENTIAL INPUT VOLTAGE EXCEEDS THE SENSITIVITY OF THE ADN2819. THE QUANTIZER WILL BE ABLE TO RECOGNIZE BOTH HIGH AND LOW STATES AT THIS POINT.

Figure 23. Example of Baseline Wander

ADN2819

DC-Coupled Application

The inputs to the ADN2819 can also be dc-coupled. This may be necessary in burst mode applications where there are long periods of CIDs and baseline wander cannot be tolerated. If the inputs to the ADN2819 are dc-coupled, care must be taken not to violate the input range and common-mode level requirements of the ADN2819 (see Figures 24–26). If dc-coupling is required, and the output levels of the TIA do not adhere to the levels shown in Figure 25 and 26, then there will need to be level shifting and/or an attenuator between the TIA outputs and the ADN2819 inputs.

LOL Toggling During Loss of Input Data

If the input data stream is lost due to a break in the optical link (or for any reason), the clock output from the ADN2819 will stay within 1000 ppm of the VCO center frequency as long as there is a valid reference clock. The LOL pin will toggle at a rate of several kHz. This is because the LOL pin will toggle between a Logic 1 and a Logic 0 while the frequency loop and phase loop swap control of the VCO. The chain of events is as follows:

- The ADN2819 is locked to the input data stream; LOL = 0.
- The input data stream is lost due to a break in the link. The VCO frequency drifts until the frequency error is greater than 1000 ppm. LOL is asserted to a Logic 1 as control of the VCO is passed back to the frequency loop.
- The frequency loop pulls the VCO to within 500 ppm of its center frequency. Control of the VCO is passed back to the phase loop and LOL is deasserted to a Logic 0.
- The phase loop tries to acquire, but there is no input data present so the VCO frequency drifts.
- The VCO frequency drifts until the frequency error is greater than 1000 ppm. LOL is asserted to a Logic 1 as control of the VCO is passed back to the frequency loop. This process is repeated until a valid input data stream is re-established.

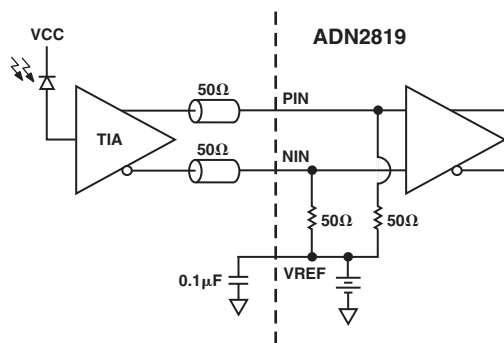

Figure 24. ADN2819 with DC-Coupled Inputs

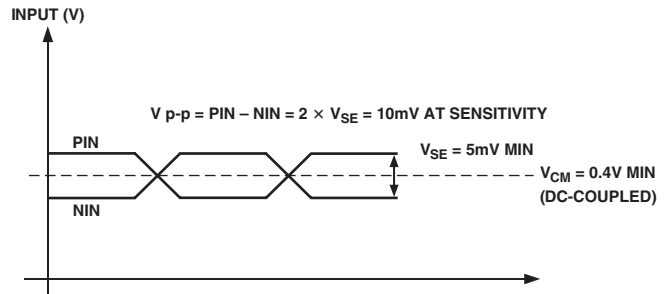

Figure 25. Minimum Allowed DC-Coupled Input Levels

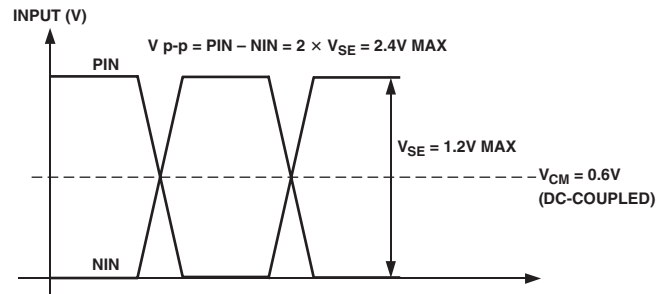
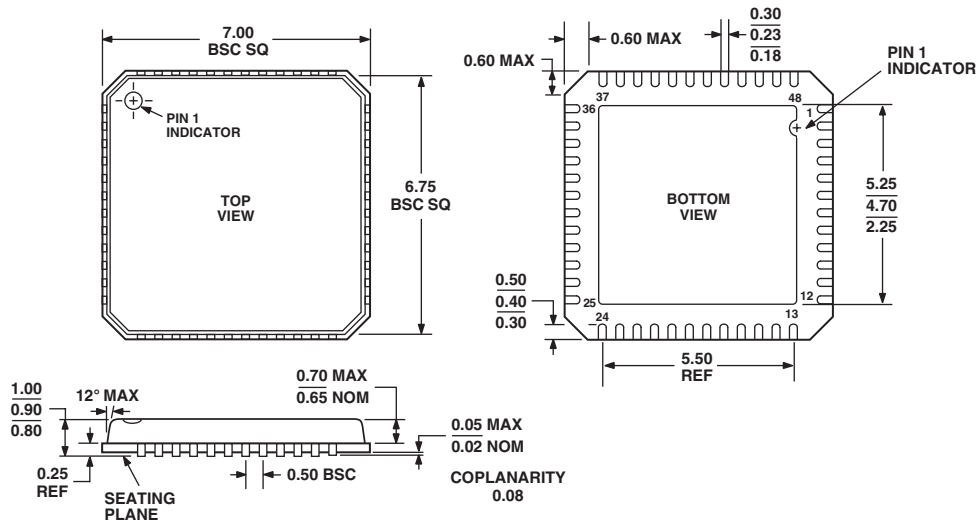

Figure 26. Maximum Allowed DC-Coupled Input Levels

OUTLINE DIMENSIONS

48-Lead Frame Chip Scale Package [LFCSP]
 7 mm × 7 mm Body
 (CP-48)

Dimensions shown in millimeters



COMPLIANT TO JEDEC STANDARDS MO-220-VKGD-2

ADN2819

Revision History

Location	Page
1/03—Data Sheet changed from REV. 0 to REV. A	
Changes to Table IV	12
Updated OUTLINE DIMENSIONS	17



LittleDiode supplies new, hard to find or obsolete electronic components and semiconductors all over the world.

With over two million different components listed you are sure to find the part you need.

Feel free to visit us today at our online store:

LittleDiode.com

Looking forward to providing you with the best possible service.