

FEATURES

- Operates at Supply Voltages from 2 V to 30 V
- Works in Step-Up or Step-Down Mode
- Very Few External Components Required
- High Frequency Operation Up to 400 kHz
- Low Battery Detector on Chip
- User Adjustable Current Limit
- Fixed and Adjustable Output Voltage
- 8-Pin DIP and SO-8 Package
- Small Inductors and Capacitors

APPLICATIONS

- Notebook, Palmtop Computers
- Cellular Telephones
- Hard Disk Drives
- Portable Instruments
- Pagers

GENERAL DESCRIPTION

The ADP3000 is a versatile step-up/step-down switching regulator that operates from an input supply voltage of 2 V to 12 V in step-up mode and up to 30 V in step-down mode.

The ADP3000 operates in Pulse Frequency Mode (PFM) and consumes only 500 μ A, making it highly suitable for applications that require low quiescent current.

The ADP3000 can deliver an output current of 100 mA at 3 V from a 5 V input in step-down configuration and 180 mA at 3.3 V from a 2 V input in step-up configuration.

The auxiliary gain amplifier can be used as a low battery detector, linear regulator undervoltage lockout or error amplifier.

The ADP3000 operates at 400 kHz switching frequency. This allows the use of small external components (inductors and capacitors), making the device very suitable for space constrained designs.

FUNCTIONAL BLOCK DIAGRAM

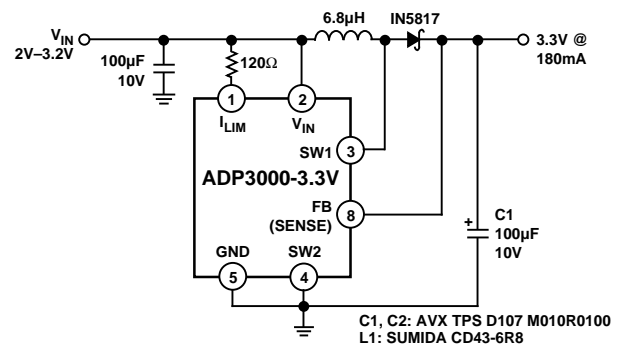
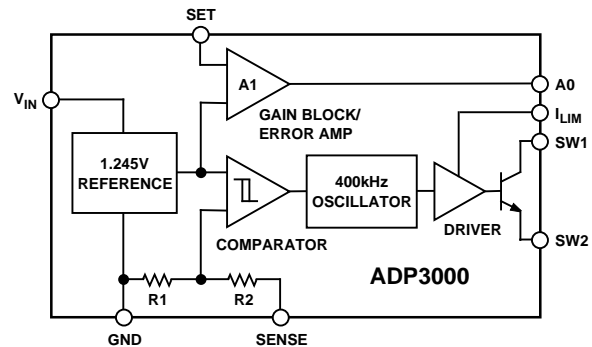

Figure 1. Typical Application

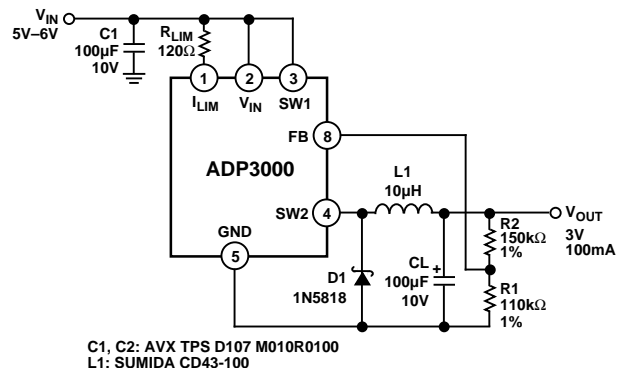

Figure 2. Step-Down Mode Operation

REV. 0

Information furnished by Analog Devices is believed to be accurate and reliable. However, no responsibility is assumed by Analog Devices for its use, nor for any infringements of patents or other rights of third parties which may result from its use. No license is granted by implication or otherwise under any patent or patent rights of Analog Devices.

ADP3000—SPECIFICATIONS ($0^{\circ}\text{C} \leq T_A \leq +70^{\circ}\text{C}$, $V_{IN} = 3\text{ V}$ unless otherwise noted)*

| Parameter | Conditions | Symbol | ADP3000 | | | Units |
|---|---|------------|---------|-------|-------|-----------------------|
| | | | Min | Typ | Max | |
| INPUT VOLTAGE | Step-Up Mode | V_{IN} | 2.0 | | 12.6 | V |
| | Step-Down Mode | | | | 30.0 | |
| SHUTDOWN QUIESCENT CURRENT | $V_{FB} > 1.43\text{ V}$; $V_{SENSE} > 1.1 \times V_{OUT}$ | I_Q | | 500 | | μA |
| COMPARATOR TRIP POINT VOLTAGE | ADP3000 ¹ | | 1.20 | 1.245 | 1.30 | V |
| OUTPUT SENSE VOLTAGE | ADP3000-3.3 ² | V_{OUT} | 3.135 | 3.3 | 3.465 | V |
| | ADP3000-5 ² | | 4.75 | 5.00 | 5.25 | V |
| | ADP3000-12 ² | | 11.40 | 12.00 | 12.60 | V |
| COMPARATOR HYSTERESIS | ADP3000 | | | 8 | 12.5 | mV |
| OUTPUT HYSTERESIS | ADP3000-3.3 | | | 32 | 50 | mV |
| | ADP3000-5 | | | 32 | 50 | mV |
| | ADP3000-12 | | | 75 | 120 | mV |
| OSCILLATOR FREQUENCY | | f_{OSC} | 350 | 400 | 450 | kHz |
| DUTY CYCLE | $V_{FB} > V_{REF}$ | D | 65 | 80 | | % |
| SWITCH ON TIME | I_{LIM} Tied to V_{IN} , $V_{FB} = 0$ | t_{ON} | 1.5 | 2 | 2.55 | μs |
| SWITCH SATURATION VOLTAGE STEP-UP MODE | $T_A = +25^{\circ}\text{C}$ | V_{SAT} | | | | V |
| | $V_{IN} = 3.0\text{ V}$, $I_{SW} = 650\text{ mA}$ | | | | | |
| | $V_{IN} = 5.0\text{ V}$, $I_{SW} = 1\text{ A}$ | | | | | |
| STEP-DOWN MODE | $V_{IN} = 12\text{ V}$, $I_{SW} = 650\text{ mA}$ | | | | | V |
| | | | | 1.1 | 1.5 | V |
| FEEDBACK PIN BIAS CURRENT | ADP3000 $V_{FB} = 0\text{ V}$ | I_{FB} | | 160 | 330 | nA |
| SET PIN BIAS CURRENT | $V_{SET} = V_{REF}$ | I_{SET} | | 200 | 400 | nA |
| GAIN BLOCK OUTPUT LOW | $I_{SINK} = 300\text{ }\mu\text{A}$ $V_{SET} = 1.00\text{ V}$ | V_{OL} | | 0.15 | 0.4 | V |
| REFERENCE LINE REGULATION | $5\text{ V} \leq V_{IN} \leq 30\text{ V}$ $2\text{ V} \leq V_{IN} \leq 5\text{ V}$ | | | 0.02 | 0.15 | %/V |
| | | | | 0.2 | 0.6 | %/V |
| GAIN BLOCK GAIN | $R_L = 100\text{ k}\Omega^3$ | A_V | 1000 | 6000 | | V/V |
| GAIN BLOCK CURRENT SINK | $V_{SET} \leq 1\text{ V}$ | I_{SINK} | | 300 | | μA |
| CURRENT LIMIT | 220 Ω from I_{LIM} to V_{IN} | I_{LIM} | | 400 | | mA |
| CURRENT LIMIT TEMPERATURE COEFFICIENT | | | | -0.3 | | %/ $^{\circ}\text{C}$ |
| SWITCH OFF LEAKAGE CURRENT | Measured at SW1 Pin $V_{SW1} = 12\text{ V}$, $T_A = +25^{\circ}\text{C}$ | | | 1 | 10 | μA |
| MAXIMUM EXCURSION BELOW GND | $T_A = +25^{\circ}\text{C}$ $I_{SW1} \leq 10\text{ }\mu\text{A}$, Switch Off | | | -400 | -350 | mV |

NOTES

¹This specification guarantees that both the high and low trip point of the comparator fall within the 1.20 V to 1.30 V range.

²The output voltage waveform will exhibit a sawtooth shape due to the comparator hysteresis. The output voltage on the fixed output versions will always be within the specified range.

³100 k Ω resistor connected between a 5 V source and the AO pin.

*All limits at temperature extremes are guaranteed via correlation using standard statistical methods. Specifications subject to change without notice.

PIN DESCRIPTIONS

| Mnemonic | Function |
|-----------|--|
| I_{LIM} | For normal conditions this pin is connected to V_{IN} . When lower current is required, a resistor should be connected between I_{LIM} and V_{IN} . Limiting the switch current to 400 mA is achieved by connecting a 220 Ω resistor. |
| V_{IN} | Input Voltage. |
| SW1 | Collector of power transistor. For step-down configuration, connect to V_{IN} . For step-up configuration, connect to an inductor/diode. |
| SW2 | Emitter of power transistor. For step-down configuration, connect to inductor/diode. For step-up configuration, connect to ground. Do not allow this pin to go more than a diode drop below ground. |
| GND | Ground. |
| AO | Auxiliary Gain (GB) output. The open collector can sink 300 μ A. It can be left open if not used. |
| SET | SET Gain amplifier input. The amplifier's positive input is connected to SET pin and its negative input is connected to 1.245 V. It can be left open if not used. |
| FB/SENSE | On the ADP3000 (adjustable) version, this pin is connected to the comparator input. On the ADP3000-3.3, ADP3000-5 and ADP3000-12, the pin goes directly to the internal resistor divider that sets the output voltage. |

ABSOLUTE MAXIMUM RATINGS

| | |
|--------------------------------------|--------------------|
| Input Supply Voltage, Step-Up Mode | 15 V |
| Input Supply Voltage, Step-Down Mode | 36 V |
| SW1 Pin Voltage | 50 V |
| SW2 Pin Voltage | -0.5 V to V_{IN} |
| Feedback Pin Voltage (ADP3000) | 5.5 V |
| Switch Current | 1.5 A |
| Maximum Power Dissipation | 500 mW |
| Operating Temperature Range | 0°C to +70°C |
| Storage Temperature Range | -65°C to +150°C |
| Lead Temperature (Soldering, 10 sec) | +300°C |
| Thermal Impedance | |
| SO-8 | 170°C/W |
| N-8 | 120°C/W |

PIN CONFIGURATIONS

8-Lead Plastic DIP (N-8)

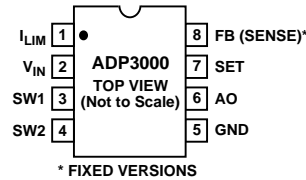

8-Lead SOIC (SO-8)

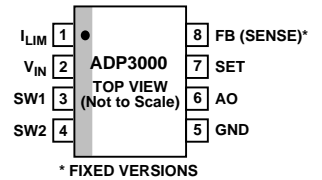

ORDERING GUIDE

| Model | Output Voltage | Package Option |
|---------------|----------------|----------------|
| ADP3000AN-3.3 | 3.3 V | N-8 |
| ADP3000AR-3.3 | 3.3 V | SO-8 |
| ADP3000AN-5 | 5 V | N-8 |
| ADP3000AR-5 | 5 V | SO-8 |
| ADP3000AN-12 | 12 V | N-8 |
| ADP3000AR-12 | 12 V | SO-8 |
| ADP3000AN | Adjustable | N-8 |
| ADP3000AR | Adjustable | SO-8 |

N = plastic DIP, SO = small outline package.

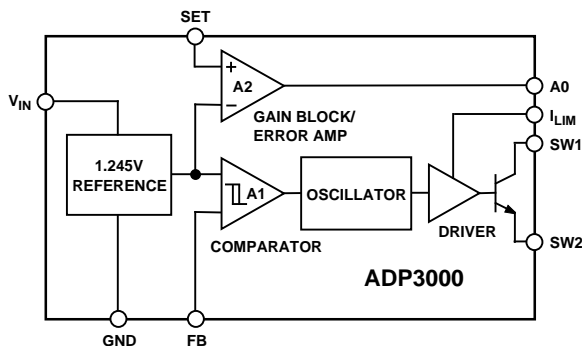

Figure 3a. Functional Block Diagram for Adjustable Version

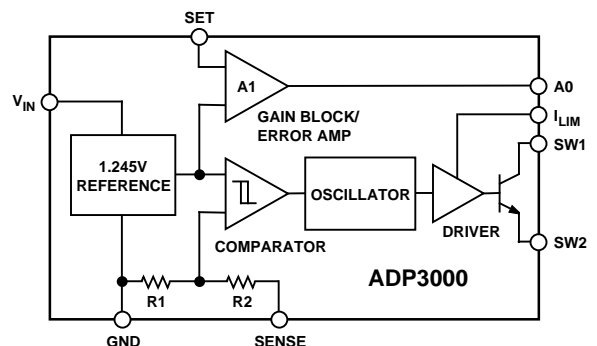

Figure 3b. Functional Block Diagram for Fixed Version

CAUTION

ESD (electrostatic discharge) sensitive device. Electrostatic charges as high as 4000 V readily accumulate on the human body and test equipment and can discharge without detection. Although the ADP3000 features proprietary ESD protection circuitry, permanent damage may occur on devices subjected to high energy electrostatic discharges. Therefore, proper ESD precautions are recommended to avoid performance degradation or loss of functionality.



ADP3000—Typical Characteristics

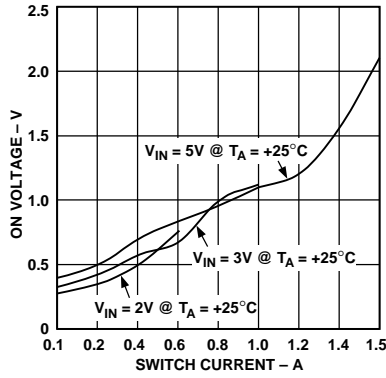

Figure 4. Switch ON Voltage vs. Switch Current in Step-Up Mode

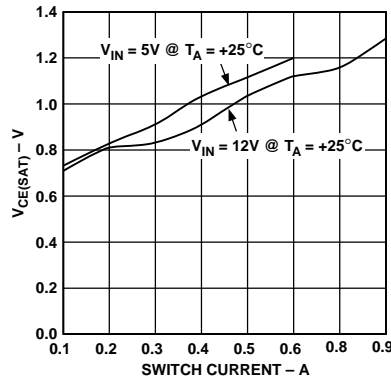

Figure 5. Saturation Voltage vs. Switch Current in Step-Down Mode

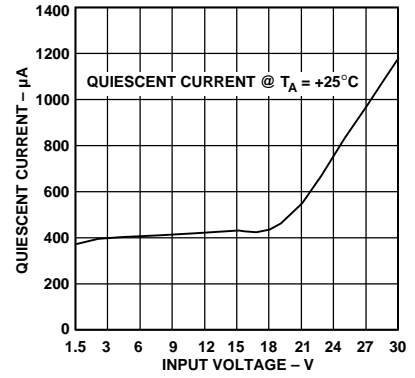

Figure 6. Quiescent Current vs. Input Voltage

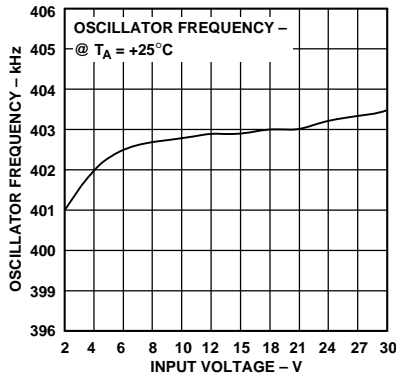

Figure 7. Oscillator Frequency vs. Input Voltage

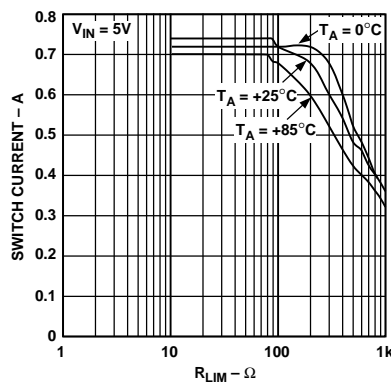

Figure 8a. Maximum Switch Current vs. R_{LIM} in Step-Down Mode (5 V)

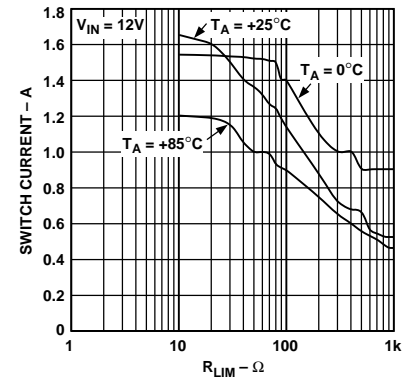

Figure 8b. Maximum Switch Current vs. R_{LIM} in Step-Down Mode (12 V)

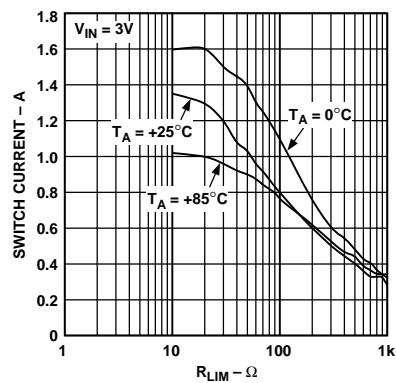

Figure 8c. Maximum Switch Current vs. R_{LIM} in Step-Up Mode (3 V)

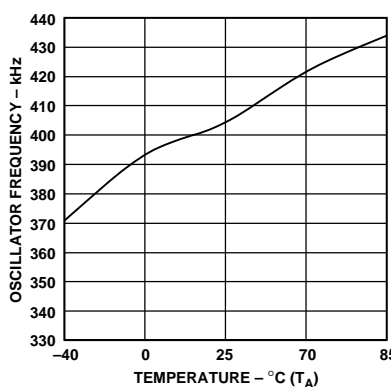

Figure 9. Oscillator Frequency vs. Temperature

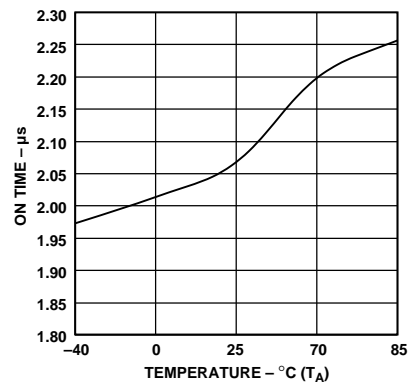

Figure 10. Switch ON Time vs. Temperature

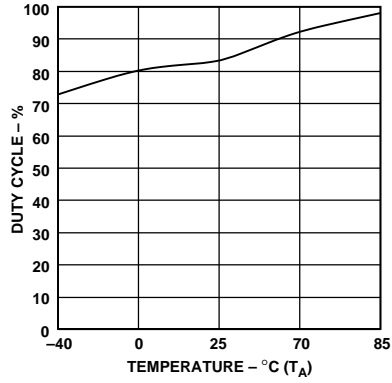

Figure 11. Duty Cycle vs. Temperature

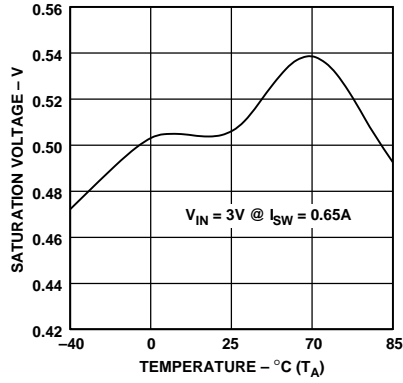

Figure 12. Saturation Voltage vs. Temperature in Step-Up Mode

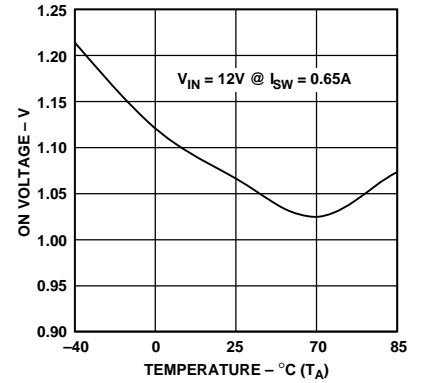

Figure 13. Switch ON Voltage vs. Temperature in Step-Down Mode

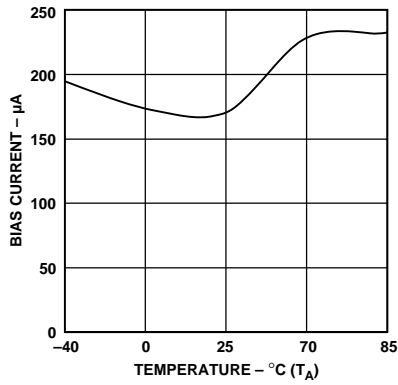

Figure 14. Feedback Bias Current vs. Temperature

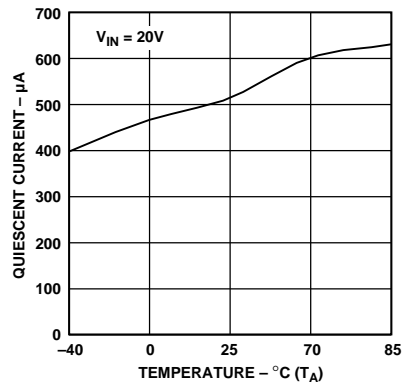

Figure 15. Quiescent Current vs. Temperature

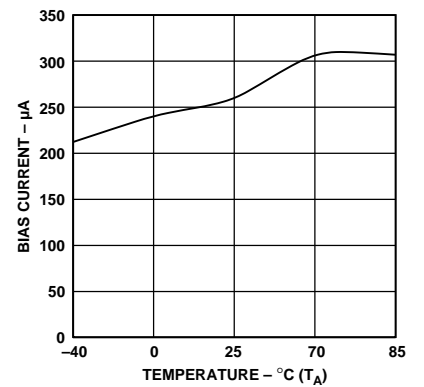

Figure 16. Set Pin Bias Current vs. Temperature

ADP3000

THEORY OF OPERATION

The ADP3000 is a versatile, high frequency, switch mode power supply (SMPS) controller. The regulated output voltage can be greater than the input voltage (boost or step-up mode) or less than the input (buck or step-down mode). This device uses a gated oscillator technique to provide high performance with low quiescent current.

A functional block diagram of the ADP3000 is shown in Figure 3a. The internal 1.245 V reference is connected to one input of the comparator, while the other input is externally connected (via the FB pin) to a resistor divider connected to the regulated output. When the voltage at the FB pin falls below 1.245 V, the 400 kHz oscillator turns on. A driver amplifier provides base drive to the internal power switch and the switching action raises the output voltage. When the voltage at the FB pin exceeds 1.245 V, the oscillator is shut off. While the oscillator is off, the ADP3000 quiescent current is only 500 μ A. The comparator's hysteresis ensures loop stability without requiring external components for frequency compensation.

The maximum current in the internal power switch can be set by connecting a resistor between V_{IN} and the I_{LIM} pin. When the maximum current is exceeded, the switch is turned OFF. The current limit circuitry has a time delay of about 0.3 μ s. If an external resistor is not used, connect I_{LIM} to V_{IN} . This yields the maximum feasible current limit. Further information on I_{LIM} is included in the "Applications" section of this data sheet. The ADP3000 internal oscillator provides typically 1.7 μ s ON and 0.8 μ s OFF times.

An uncommitted gain block on the ADP3000 can be connected as a low battery detector. The inverting input of the gain block is internally connected to the 1.245 V reference. The noninverting input is available at the SET pin. A resistor divider, connected between V_{IN} and GND with the junction connected to the SET pin, causes the AO output to go LOW when the low battery set point is exceeded. The AO output is an open collector NPN transistor that can sink in excess of 300 μ A.

The ADP3000 provides external connections for both the collector and emitter of its internal power switch, which permits both step-up and step-down modes of operation. For the step-up mode, the emitter (Pin SW2) is connected to GND and the collector (Pin SW1) drives the inductor. For step-down mode, the emitter drives the inductor while the collector is connected to V_{IN} .

The output voltage of the ADP3000 is set with two external resistors. Three fixed voltage models are also available: ADP3000-3.3 (+3.3 V), ADP3000-5 (+5 V) and ADP3000-12 (+12 V). The fixed voltage models include laser-trimmed voltage-setting resistors on the chip. On the fixed voltage models of the ADP3000, simply connect the feedback pin (Pin 8) directly to the output voltage.

APPLICATIONS INFORMATION

COMPONENT SELECTION

Inductor Selection

For most applications the inductor used with the ADP3000 will fall in the range between 4.7 μ H to 33 μ H. Table I shows recommended inductors and their vendors.

When selecting an inductor, it is very important to make sure that the inductor used with the ADP3000 is able to handle a current that is higher than the ADP3000's current limit without saturation.

As a rule of thumb, powdered iron cores saturate softly, whereas Ferrite cores saturate abruptly. Rod or "open" drum core geometry inductors saturate gradually. Inductors that saturate gradually are easier to use. Even though rod or drum core inductors are attractive in both price and physical size, these types of inductors must be handled with care because they have high magnetic radiation. Toroid or "closed" core geometry should be used when minimizing EMI is critical.

In addition, inductor dc resistance causes power loss. It is best to use low dc resistance inductors so that power loss in the inductor is kept to the minimum. Typically, it is best to use an inductor with a dc resistance lower than 0.2 Ω .

Table I. Recommended Inductors

| Vendor | Series | Core Type | Phone Numbers |
|-------------|------------------------|----------------------|----------------|
| Coiltronics | OCTAPAC | Toroid | (407) 241-7876 |
| Coiltronics | UNIPAC | Open | (407) 241-7876 |
| Sumida | CD43, CD54 | Open | (847) 956-0666 |
| Sumida | CDRH62, CDRH73, CDRH64 | Semi-Closed Geometry | (847) 956-0666 |

Capacitor Selection

For most applications, the capacitor used with the ADP3000 will fall in the range between 33 μ F to 220 μ F. Table II shows recommended capacitors and their vendors.

For input and output capacitors, use low ESR type capacitors for best efficiency and lowest ripple. Recommended capacitors include AVX TPS series, Sprague 595D series, Panasonic HFQ series and Sanyo OS-CON series.

When selecting a capacitor, it is important to make sure the maximum capacitor ripple current rms rating is higher than the ADP3000's rms switching current.

It is best to protect the input capacitor from high turn-on current charging surges by derating the capacitor voltage by 2:1. For very low input or output voltage ripple requirements, Sanyo OS-CON series capacitors can be used since this type of capacitor has very low ESR. Alternatively, two or more tantalum capacitors can be used in parallel.

Table II. Recommended Capacitors

| Vendor | Series | Type | Phone Numbers |
|-----------|--------|---------------|----------------|
| AVX | TPS | Surface Mount | (803) 448-9411 |
| Sanyo | OS-CON | Through-Hole | (619) 661-6835 |
| Sprague | 595D | Surface Mount | (603) 224-1961 |
| Panasonic | HFQ | Through-Hole | (201) 348-5200 |

DIODE SELECTION

The ADP3000's high switching speed demands the use of Schottky diodes. Suitable choices include the 1N5817, 1N5818, 1N5819, MBR5120LT3 and MBR0520LT1. Do not use fast recovery diodes because their high forward drop lowers efficiency. Neither general-purpose diodes nor small signal diodes should be used.

PROGRAMMING THE SWITCHING CURRENT LIMIT OF THE POWER SWITCH

The ADP3000's R_{LIM} pin permits the cycle by cycle switch current limit to be programmed with a single external resistor. This feature offers major advantages which ultimately decrease the component cost and P.C.B. real estate. First, it allows the ADP3000 to use low value, low saturation current and physically small inductors. Additionally, it allows the ADP3000 to use a physically small surface mount tantalum capacitor with a typical ESR of 0.1Ω to achieve an output ripple as low as 40 mV to 80 mV, as well as low input ripple.

As a rule of thumb, the current limit is usually set to approximately 3 to 5 times the full load current for boost applications and about 1.5–3 times of the full load current in buck applications.

The internal structure of the I_{LIM} circuit is shown in Figure 17. Q1 is the ADP3000's internal power switch, which is paralleled by sense transistor Q2. The relative sizes of Q1 and Q2 are scaled so that I_{Q2} is 0.5% of I_{Q1} . Current flows to Q2 through both an internal 80Ω resistor and the R_{LIM} resistor. The voltage on these two resistors biases the base-emitter junction of the oscillator-disable transistor, Q3. When the voltage across R1 and R_{LIM} exceeds 0.6 V, Q3 turns on and terminates the output pulse. If only the 80Ω internal resistor is used (i.e. the I_{LIM} pin is connected directly to V_{IN}), the maximum switch current will be 1.5 A. Figure 8a gives values for lower current-limit values.

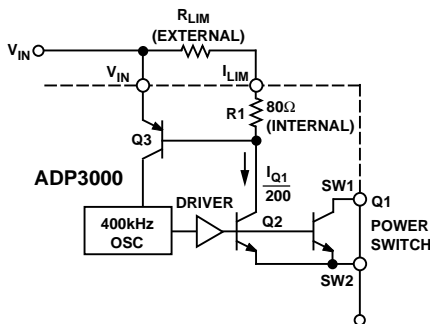

Figure 17. ADP3000 Current Limit Operation

The delay through the current limiting circuit is approximately $0.3 \mu s$. If the switch ON time is reduced to less than $1.7 \mu s$, accuracy of the current trip-point is reduced. Attempting to program a switch ON time of $0.3 \mu s$ or less will produce spurious responses in the switch ON time. However, the ADP3000 will still provide a properly regulated output voltage.

PROGRAMMING THE GAIN BLOCK

The gain block of the ADP3000 can be used as a low battery detector, error amplifier or linear post regulator. The gain block consists of an op amp with PNP inputs and an open-collector NPN output. The inverting input is internally connected to the ADP3000's 1.245 V reference, while the noninverting input is available at the SET pin. The NPN output transistor will sink in excess of 300 μA .

Figure 18 shows the gain block configured as a low battery monitor. Resistors R1 and R2 should be set to high values to reduce quiescent current, but not so high that bias current in the SET input causes large errors. A value of $33 \text{ k}\Omega$ for R2 is a good compromise. The value for R1 is then calculated from the formula:

$$R1 = \frac{V_{LOBATT} - 1.245 \text{ V}}{\frac{1.245 \text{ V}}{R2}}$$

where V_{LOBATT} is the desired low battery trip point. Since the gain block output is an open-collector NPN, a pull-up resistor should be connected to the positive logic power supply.

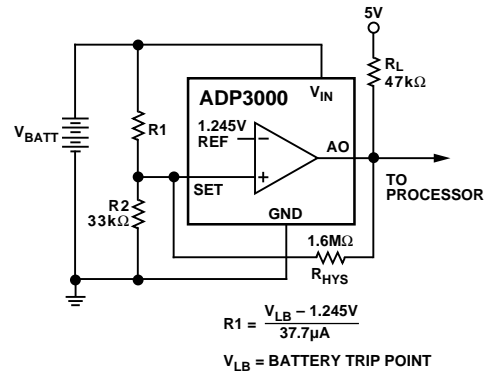

Figure 18. Setting the Low Battery Detector Trip Point

ADP3000

The circuit of Figure 18 may produce multiple pulses when approaching the trip point due to noise coupled into the SET input. To prevent multiple interrupts to the digital logic, hysteresis can be added to the circuit (Figure 18). Resistor R_{HYS} , with a value of 1 M Ω to 10 M Ω , provides the hysteresis. The addition of R_{HYS} will change the trip point slightly, so the new value for R1 will be:

$$R1 = \frac{V_{LOBATT} - 1.245 V}{\left(\frac{1.245 V}{R2}\right) - \left(\frac{V_L - 1.245 V}{R_L + R_{HYS}}\right)}$$

where V_L is the logic power supply voltage, R_L is the pull-up resistor, and R_{HYS} creates the hysteresis.

POWER TRANSISTOR PROTECTION DIODE IN STEP-DOWN CONFIGURATION

When operating the ADP3000 in the step-down mode, the output voltage is impressed across the internal power switch's emitter-base junction when the switch is off. In order to protect the switch, a Schottky diode must be placed in a series with SW2 when the output voltage is set to higher than 6 V. Figure 19 shows the proper way to place the protection diode, D2. The selection of this diode is identical to the step-down commutating diode (see Diode Selection section for information).

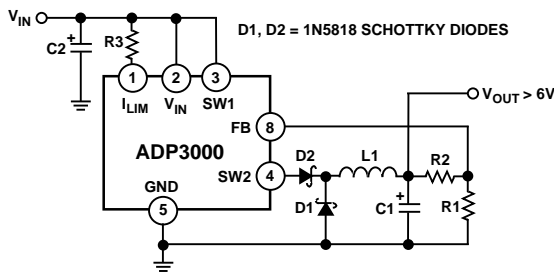

Figure 19. Step-Down Model $V_{OUT} > 6.0 V$

THERMAL CONSIDERATIONS

Power dissipation internal to the ADP3000 can be approximated with the following equations.

Step-Up

$$P_D = \left[I_{SW}^2 R + \frac{V_{IN} I_{SW}}{\beta} \right] D \left[1 - \frac{V_{IN}}{V_O} \right] \left[\frac{4 I_O}{I_{SW}} \right] + [I_Q][V_{IN}]$$

where: I_{SW} is I_{LIMIT} in the case of current limit programmed externally, or maximum inductor current in the case of current limit not programmed externally.

$R = 1 \Omega$ (Typical $R_{CE(SAT)}$).

$D = 0.75$ (Typical Duty Ratio for a Single Switching Cycle).

$V_O =$ Output Voltage.

$I_O =$ Output Current.

$V_{IN} =$ Input Voltage.

$I_Q = 500 \mu A$ (Typical Shutdown Quiescent Current).

$\beta = 30$ (Typical Forced Beta)

Step-Down

$$P_D = \left[I_{SW} V_{CESAT} \left(1 + \frac{1}{\beta} \right) \right] \left[\frac{V_O}{V_{IN} - V_{CE(SAT)}} \right] \left[\frac{2 I_O}{I_{SW}} \right] + [I_Q][V_{IN}]$$

where: I_{SW} is I_{LIMIT} in the case of current limit is programmed externally or maximum inductor current in the case of current limit is not programmed externally.

$V_{CE(SAT)}$ = Check this value by applying I_{SW} to Figure 8b. 1.2 V is typical value.

$D = 0.75$ (Typical Duty Ratio for a Single Switching Cycle).

$V_O =$ Output Voltage.

$I_O =$ Output Current.

$V_{IN} =$ Input Voltage.

$I_Q = 500 \mu A$ (Typical Shutdown Quiescent Current).

$\beta = 30$ (Typical Forced Beta).

The temperature rise can be calculated from:

$$\Delta T = P_D \times \theta_{JA}$$

where:

$\Delta T =$ Temperature Rise.

$P_D =$ Device Power Dissipation.

$\theta_{JA} =$ Thermal Resistance (Junction-to-Ambient).

As example, consider a boost converter with the following specifications:

$V_{IN} = 2 V$, $I_O = 180 mA$, $V_O = 3.3 V$.

$I_{SW} = 0.8 A$ (Externally Programmed).

With Step-Up Power Dissipation Equation:

$$P_D = \left[0.8^2 \times 1 + \frac{(2)(0.8)}{30} \right] [0.75] \left[1 - \frac{2}{3.3} \right] \left[\frac{(4)(0.18)}{0.8} \right] + [500E-6][2]$$

$$= 185 mW$$

Using the SO-8 Package: $\Delta T = 185 mW (170^\circ C/W) = 31.5^\circ C$.

Using the N-8 Package: $\Delta T = 185 mW (120^\circ C/W) = 22.2^\circ C$.

At a 70°C ambient, die temperature would be 101.45°C for SO-8 package and 92.2°C for N-8 package. These junction temperatures are well below the maximum recommended junction temperature of 125°C.

Finally, the die temperature can be decreased up to 20% by using a large metal ground plate as ground pickup for the ADP3000.

Typical Application Circuits

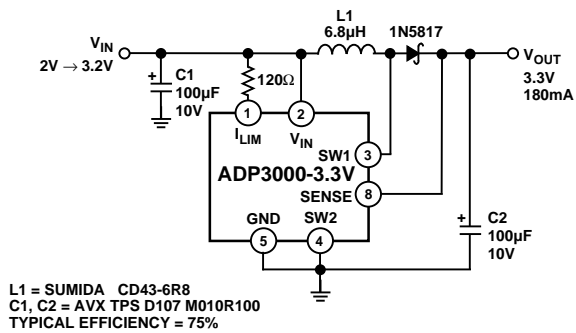

Figure 20. 2 V to 3.3 V/180 mA Step-Up Converter

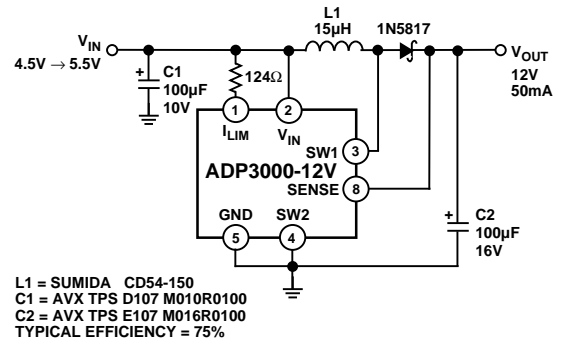

Figure 23. 4.5 V to 12 V/50 mA Step-Up Converter

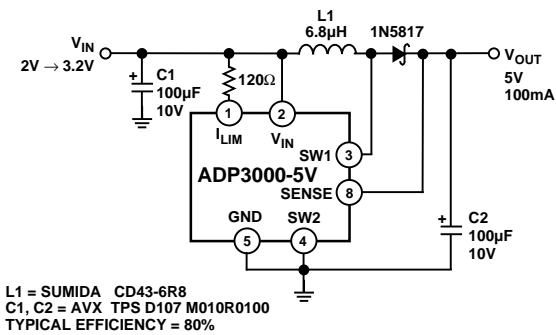

Figure 21. 2 V to 5 V/100 mA Step-Up Converter

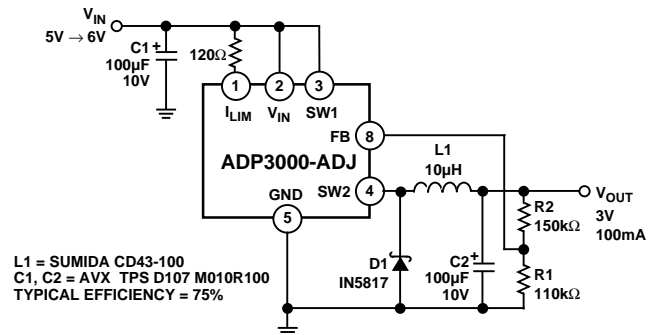

Figure 24. 5 V to 3 V/100 mA Step-Down Converter

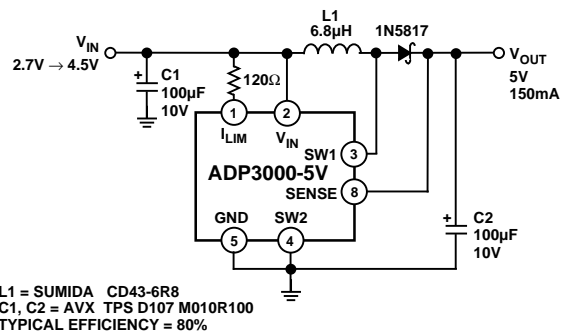

Figure 22. 2.7 V to 5 V/150 mA Step-Up Converter

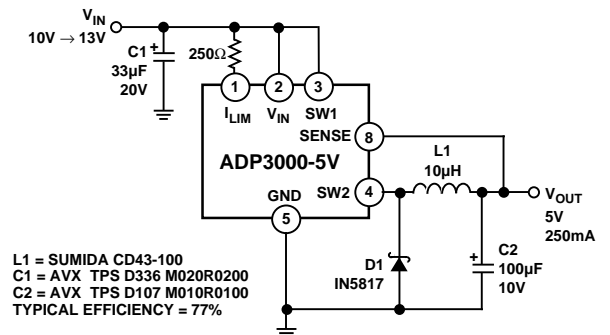

Figure 25. 10 V to 5 V/250 mA Step-Down Converter

ADP3000

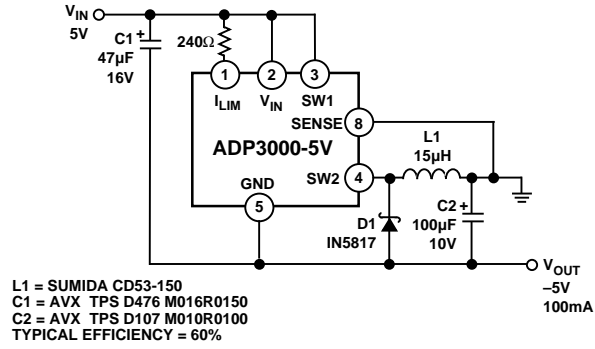

Figure 26. 5 V to -5 V/100 mA Inverter

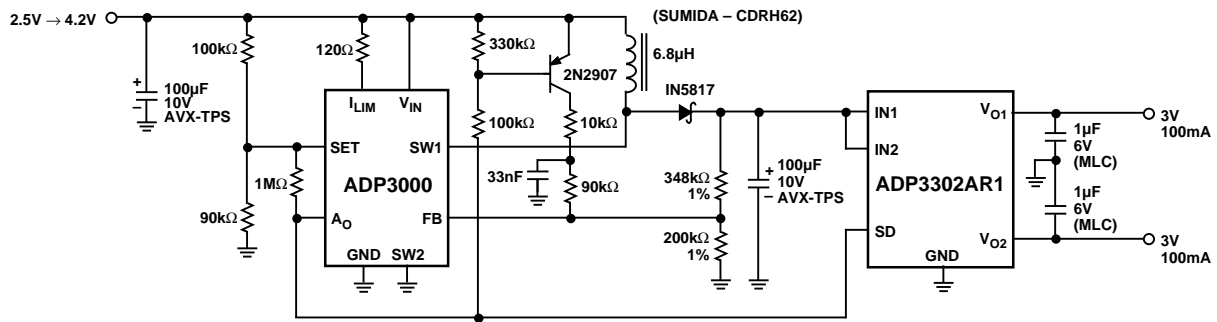

Figure 27. 1 Cell LI-ION to 3 V/200 mA Converter with Shutdown at $V_{IN} \leq 2.5 V$

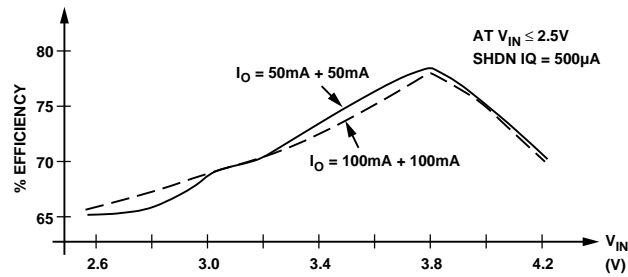
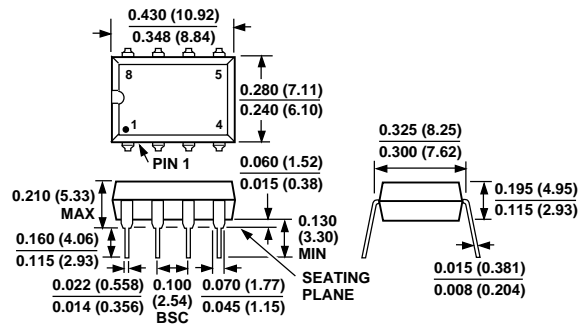

Figure 28. Typical Efficiency of the Circuit of Figure 27

OUTLINE DIMENSIONS

Dimensions shown in inches and (mm).

8-Lead Plastic DIP (N-8)



8-Lead SOIC (SO-8)

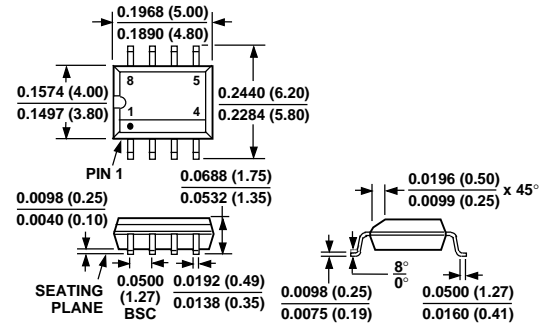



LittleDiode supplies new, hard to find or obsolete electronic components and semiconductors all over the world.

With over two million different components listed you are sure to find the part you need.

Feel free to visit us today at our online store:

LittleDiode.com

Looking forward to providing you with the best possible service.