



ADS803

## *SpeedPLUS*™ 12-Bit, 5MHz Sampling ANALOG-TO-DIGITAL CONVERTER

### FEATURES

- HIGH SFDR: 82dB at NYQUIST
- HIGH SNR: 69dB
- LOW POWER: 115mW
- LOW DLE: 0.25LSB
- SMALL 28-LEAD SSOP AND SOIC PACKAGES

- FLEXIBLE INPUT RANGE
- OVER-RANGE INDICATOR

### APPLICATIONS

- IF AND BASEBAND DIGITIZATION
- CCD IMAGING SCANNERS
- TEST INSTRUMENTATION

### DESCRIPTION

The ADS803 is a high-speed, high dynamic range, 12-bit pipelined analog-to-digital converter. This converter includes a high-bandwidth track/hold that gives excellent spurious performance up to and beyond the Nyquist rate. This high-bandwidth, linear track/hold minimizes harmonics and has low jitter, leading to excellent SNR performance. The ADS803 is also pin-compatible with the 10MHz ADS804 and the 20MHz ADS805.

The ADS803 provides an internal reference and can be programmed for a 2Vp-p input range for the best spurious performance and ease of driving. Alternatively, the 5Vp-p input range can be used for the lowest input referred noise of 0.09 LSBs rms giving superior imaging performance. There is also a capability to set the input

range in between the 2Vp-p and 5Vp-p input ranges or to use external reference. The ADS803 also provides an overrange indicator flag to indicate an input range that exceeds the full-scale input range of the converter. This flag can be used to reduce the gain of the front end gain-ranging circuitry.

The ADS803 employs digital error correction techniques to provide excellent differential linearity for demanding imaging applications. Its low distortion and high SNR give the extra margin needed for communications, medical imaging, video and test instrumentation applications. The ADS803 is available in 28-lead SSOP and SOIC packages.

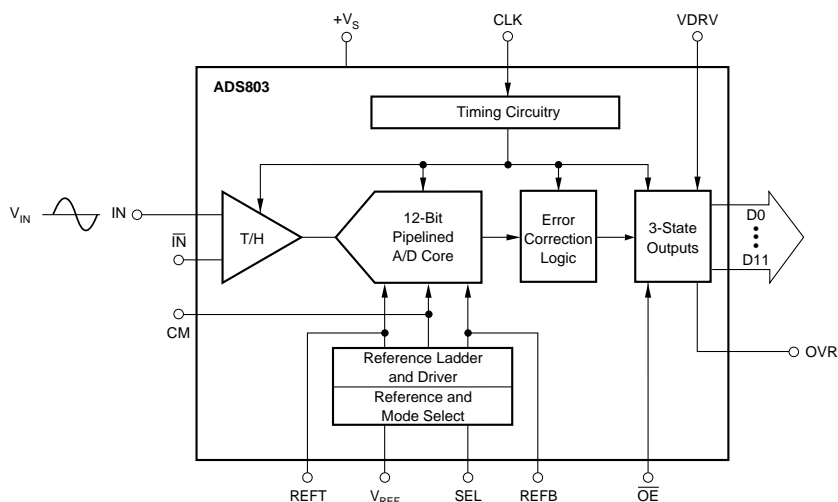

International Airport Industrial Park • Mailing Address: PO Box 11400, Tucson, AZ 85734 • Street Address: 6730 S. Tucson Blvd., Tucson, AZ 85706 • Tel: (520) 746-1111 • Twx: 910-952-1111  
Internet: <http://www.burr-brown.com/> • FAXLine: (800) 548-6133 (US/Canada Only) • Cable: BBRCORP • Telex: 066-6491 • FAX: (520) 889-1510 • Immediate Product Info: (800) 548-6132

# SPECIFICATIONS

At  $T_A$  = full specified temperature range,  $V_S = +5V$ , specified input range = 1.5V to 3.5V, single-ended input and sampling rate = 5MHz, unless otherwise specified.

PARAMETER	CONDITIONS	ADS803U			ADS803E			UNITS
		MIN	TYP	MAX	MIN	TYP	MAX	
<b>RESOLUTION</b>		12 Guaranteed				*(1)		Bits
<b>SPECIFIED TEMPERATURE RANGE</b>		-40 to +85			-40 to +85			°C
<b>CONVERSION CHARACTERISTICS</b>								
Sample Rate		10k		5M	*		*	Samples/s
Data Latency			6			*		Clk Cycles
<b>ANALOG INPUT</b>								
Single-Ended Input Range		1.5		3.5	*		*	V
Standard Optional Single-Ended Input Range		0		5	*		*	V
Common-Mode Voltage			2.5			*		V
Standard Optional Common-Mode Voltage			1			*		V
Input Capacitance			20			*		pF
Track-Mode Input Bandwidth	-3dBFS Input		270			*		MHz
<b>DYNAMIC CHARACTERISTICS</b>								
Differential Linearity Error (Largest Code Error)			±0.25	±0.75		*	*	LSB
f = 500kHz			Guaranteed			Guaranteed		
No Missing Codes								
Spurious Free Dynamic Range <sup>(2)</sup>		74	82		*	*		dBFS
f = 2.48MHz (-1dB input)			74			*		dBc
Two-Tone Intermodulation Distortion <sup>(4)</sup>								
f = 1.8M and 1.9M (-7dBFS each tone)								
Signal-to-Noise Ratio (SNR)		66.5	69		*	*		dB
f = 2.48MHz (-1dB input)								
Signal-to-(Noise + Distortion) (SINAD)		65	68		*	*		dB
f = 2.48MHz (-1dB input)			11			*		Bits
Effective Number of Bits at 2.48MHz <sup>(5)</sup>			0.09			*		LSBs rms
Input Referred Noise	0V to 5V Input		0.23			*		LSBs rms
	1.5V to 3.5V Input					*		
Integral Nonlinearity Error			±1	±2		*	*	LSB
f = 500kHz			1			*		ns
Aperture Delay Time			4			*		ps rms
Aperture Jitter			2			*		ns
Overvoltage Recovery Time	1.5 x FS Input		50			*		ns
Full-Scale Step Acquisition Time						*		ns
<b>DIGITAL INPUTS</b>								
Logic Family		CMOS Compatible			CMOS Compatible			
Convert Command	Start Conversion	Rising Edge of Convert Clock			Rising Edge of Convert Clock			
High Level Input Current ( $V_{IN} = 5V$ ) <sup>(6)</sup>				100			*	µA
Low Level Input Current ( $V_{IN} = 0V$ )				±10			*	µA
High Level Input Voltage		+3.5		+1.0	*		*	V
Low Level Input Voltage							*	V
Input Capacitance			5			*		pF
<b>DIGITAL OUTPUTS</b>								
Logic Family		CMOS/TTL Compatible			CMOS/TTL Compatible			V
Logic Coding		Straight Offset Binary			Straight Offset Binary			
Low Output Voltage	( $I_{OL} = 50\mu A$ )			0.1			*	V
Low Output Voltage	( $I_{OL} = 1.6mA$ )			0.4			*	V
High Output Voltage	( $I_{OH} = 50\mu A$ )	+4.5			*		*	V
High Output Voltage	( $I_{OH} = 0.5mA$ )	+2.4			*		*	V
3-State Enable Time	$\overline{OE} = L$		20	40		*	*	ns
3-State Disable Time	$\overline{OE} = H$		2	10		*	*	ns
Output Capacitance			5			*		pF
<b>ACCURACY (5Vp-p Input Range)</b>								
Zero Error (Referred to -FS)	At 25°C		0.2	±1.5		*	*	%FS
Zero Error Drift (Referred to -FS)			±5			*		ppm/°C
Gain Error <sup>(7)</sup>	At 25°C			±2.0		*	*	%FS
Gain Error Drift <sup>(7)</sup>			±15			*		ppm/°C
Gain Error <sup>(8)</sup>	At 25°C			±1.5		*	*	%FS
Gain Error Drift <sup>(8)</sup>			±15			*		ppm/°C
Power Supply Rejection of Gain	$\Delta V_S = \pm 5\%$	60	82		*	*	*	dB
Reference Input Resistance			1.6			*		kΩ
Internal Voltage Reference Tolerance ( $V_{REF} = 2.5V$ )	At 25°C			±35			*	mV
Internal Voltage Reference Tolerance ( $V_{REF} = 1.0V$ )	At 25°C			±14			*	mV

# SPECIFICATIONS (CONT)

At  $T_A$  = full specified temperature range,  $V_S = +5V$ , specified input range = 1.5V to 3.5V, single-ended input and sampling rate = 5MHz, unless otherwise specified.

PARAMETER	CONDITIONS	ADS803U			ADS803E			UNITS
		MIN	TYP	MAX	MIN	TYP	MAX	
<b>POWER SUPPLY REQUIREMENTS</b> Supply Voltage: $+V_S$ Supply Current: $+I_S$ Power Dissipation Thermal Resistance, $\theta_{JA}$ 28-Lead SOIC 28-Lead SSOP	Operating	+4.7	+5.0	5.3	*	*	*	V
	Operating		23	27		*	*	mA
	Operating		115	135		*	*	mW
				75				$^{\circ}C/W$
						50		$^{\circ}C/W$

NOTES: (1) An asterisk (\*) indicates same specifications as the ADS803U. (2) Spurious Free Dynamic Range refers to the magnitude of the largest harmonic. (3) dBFS means dB relative to full scale. (4) Two-tone intermodulation distortion is referred to the largest fundamental tone. This number will be 6dB higher if it is referred to the magnitude of the two-tone fundamental envelope. (5) Effective number of bits (ENOB) is defined by  $(SINAD - 1.76)/6.02$ . (6) Internal 50k $\Omega$  pull-down resistor. (7) Includes internal reference. (8) Excludes internal reference.

## ABSOLUTE MAXIMUM RATINGS

$+V_S$ .....	+6V
Analog Input .....	(-0.3V) to $(+V_S + 0.3V)$
Logic Input .....	(-0.3V) to $(+V_S + 0.3V)$
Case Temperature .....	+100 $^{\circ}C$
Junction Temperature .....	+150 $^{\circ}C$
Storage Temperature .....	+150 $^{\circ}C$



## ELECTROSTATIC DISCHARGE SENSITIVITY

This integrated circuit can be damaged by ESD. Burr-Brown recommends that all integrated circuits be handled with appropriate precautions. Failure to observe proper handling and installation procedures can cause damage.

ESD damage can range from subtle performance degradation to complete device failure. Precision integrated circuits may be more susceptible to damage because very small parametric changes could cause the device not to meet its published specifications.

## DEMO BOARD ORDERING INFORMATION

PRODUCT	DEMO BOARD
ADS803U	DEM-ADS80xU

## PACKAGE/ORDERING INFORMATION

PRODUCT	PACKAGE	PACKAGE DRAWING NUMBER <sup>(1)</sup>	SPECIFIED TEMPERATURE RANGE	PACKAGE MARKING	ORDERING NUMBER	TRANSPORT MEDIA
ADS803U	SO-28 Surface Mount	217	-40 $^{\circ}C$ to +85 $^{\circ}C$	ADS803U	ADS803U	Rails
ADS803E	SSOP-28 Surface Mount	324	-40 $^{\circ}C$ to +85 $^{\circ}C$	ADS803E	ADS803E	Rails
"	"	"	"	"	ADS803E/1K	Tape and Reel

NOTES: (1) For detailed drawing and dimension table, please see end of data sheet, or Appendix C of Burr-Brown IC Data Book. For detailed Tape and Reel mechanical information refer to Appendix B of Burr-Brown IC Data Book.

The information provided herein is believed to be reliable; however, BURR-BROWN assumes no responsibility for inaccuracies or omissions. BURR-BROWN assumes no responsibility for the use of this information, and all use of such information shall be entirely at the user's own risk. Prices and specifications are subject to change without notice. No patent rights or licenses to any of the circuits described herein are implied or granted to any third party. BURR-BROWN does not authorize or warrant any BURR-BROWN product for use in life support devices and/or systems.

## PIN CONFIGURATION

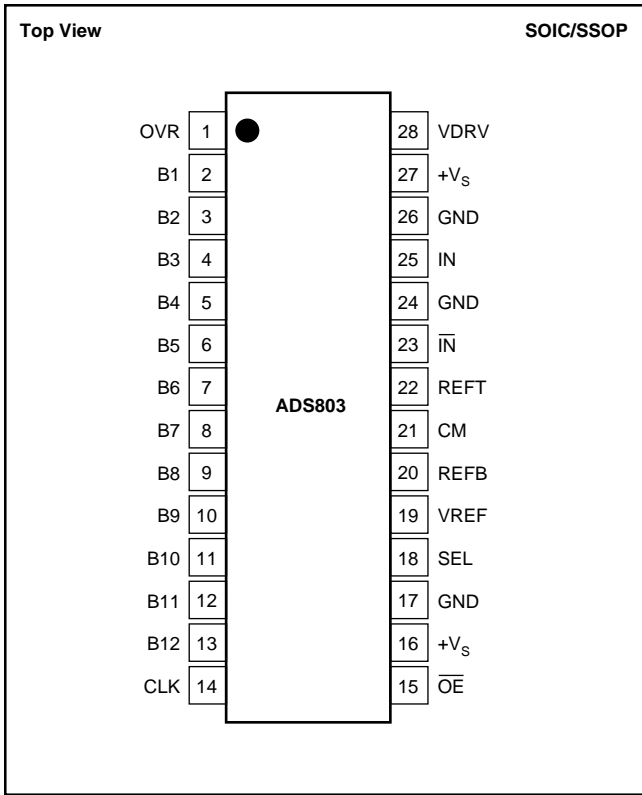

## PIN DESCRIPTIONS

PIN	DESIGNATOR	DESCRIPTION
1	OVR	Over Range Indicator
2	B1	Data Bit 1 (MSB)
3	B2	Data Bit 2
4	B3	Data Bit 3
5	B4	Data Bit 4
6	B5	Data Bit 5
7	B6	Data Bit 6
8	B7	Data Bit 7
9	B8	Data Bit 8
10	B9	Data Bit 9
11	B10	Data Bit 10
12	B11	Data Bit 11
13	B12	Data Bit 12 (LSB)
14	CLK	Convert Clock Input
15	OE	Output Enable
16	+Vs	+5V Supply
17	GND	Ground
18	SEL	Input Range Select
19	VREF	Reference Voltage Select
20	REFB	Bottom Reference
21	CM	Common-Mode Voltage
22	REFT	Top Reference
23	iN	Complementary Analog Input
24	GND	Analog Ground
25	IN	Analog Input (+)
26	GND	Analog Ground
27	+Vs	+5V Supply
28	VDRV	Output Driver Voltage

## TIMING DIAGRAM

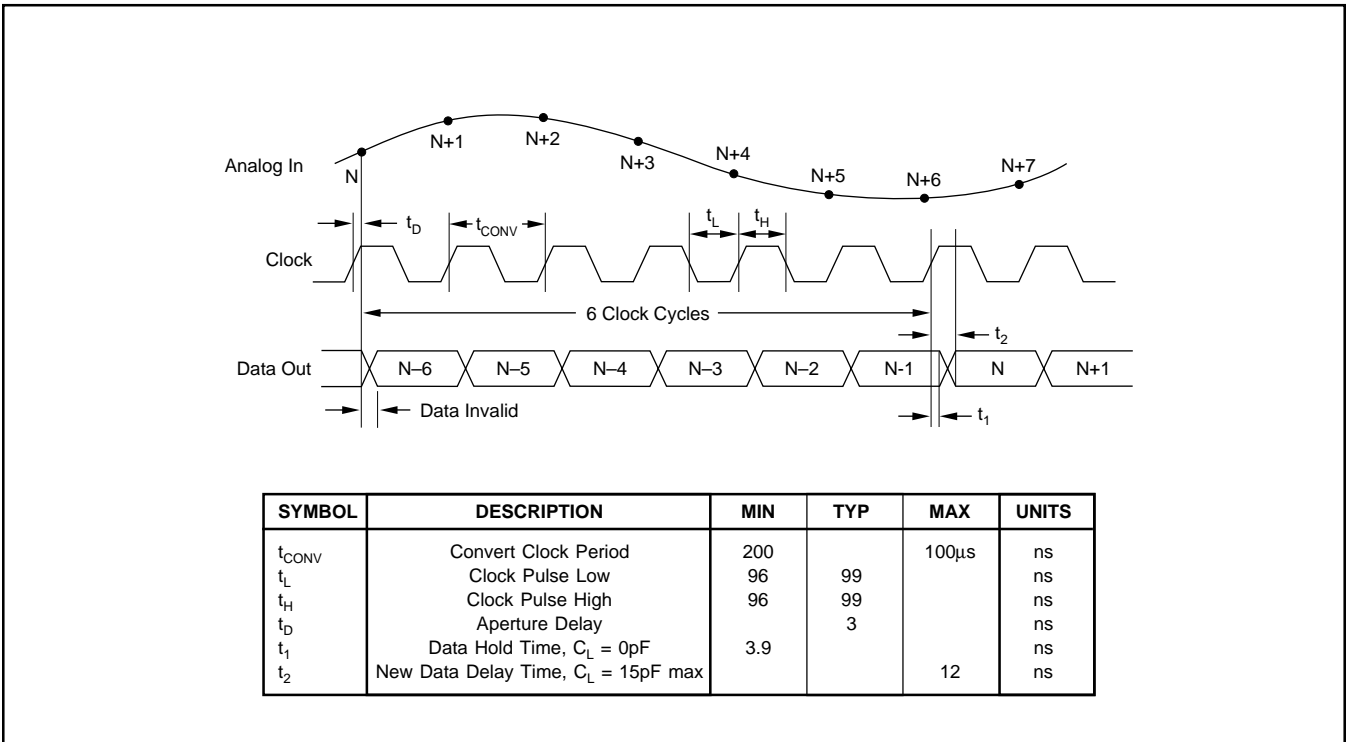

# TYPICAL PERFORMANCE CURVES

At  $T_A$  = full specified temperature range,  $V_S$  = +5V, specified input range = 1.5V to 3.5V, single-ended input and sampling rate = 5MHz, unless otherwise specified.

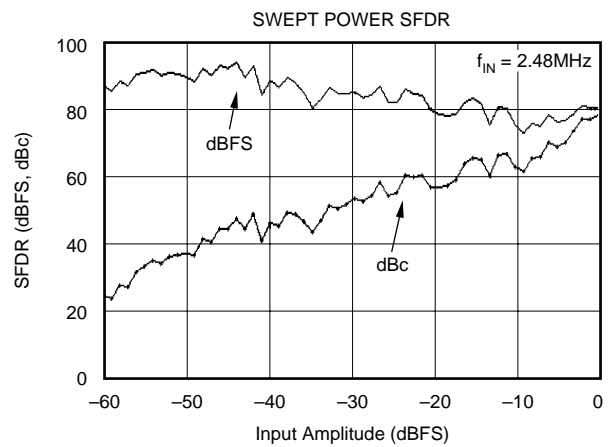
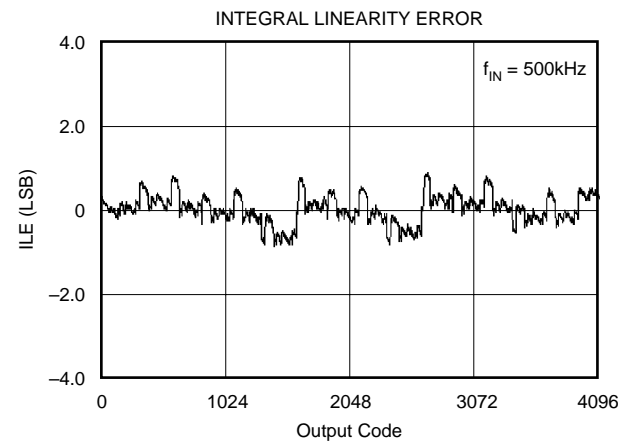
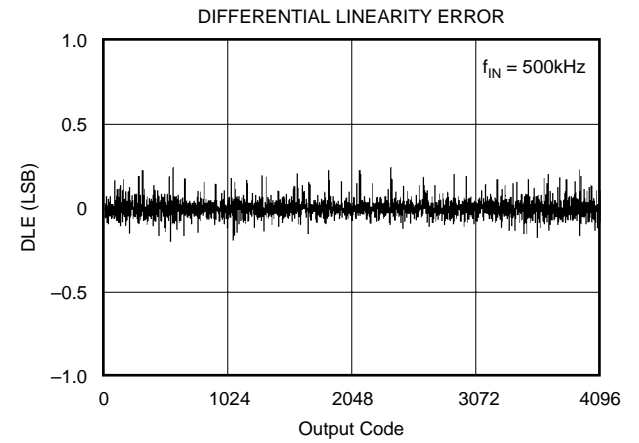
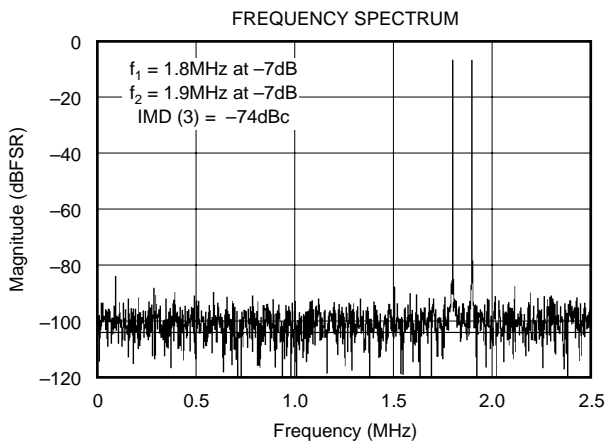
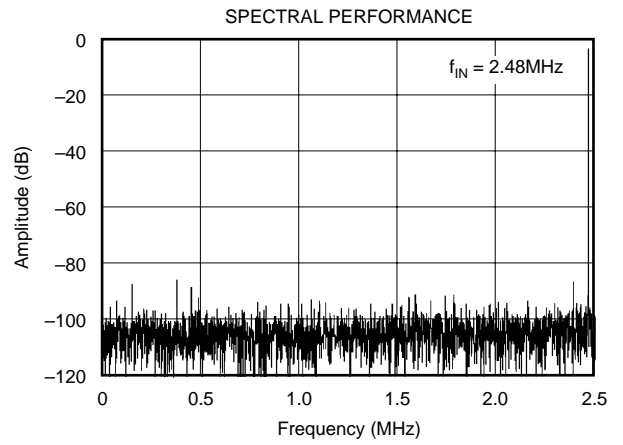
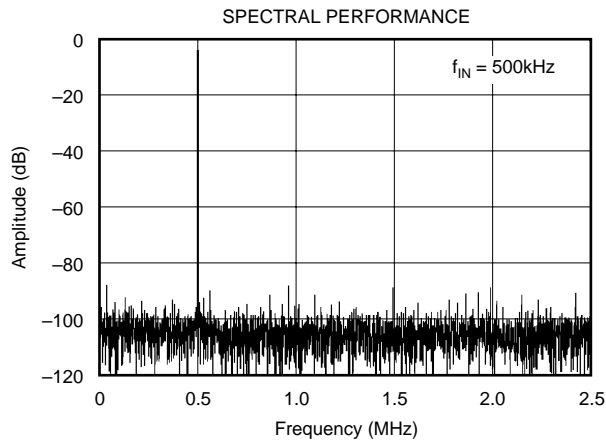

# TYPICAL PERFORMANCE CURVES

At  $T_A$  = full specified temperature range,  $V_S$  = +5V, specified input range = 1.5V to 3.5V, single-ended input and sampling rate = 5MHz, unless otherwise specified.

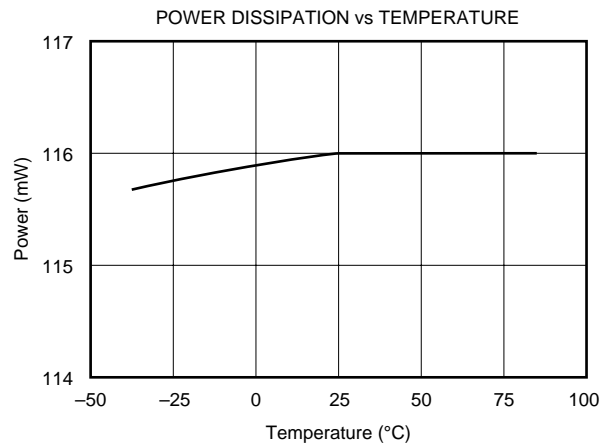
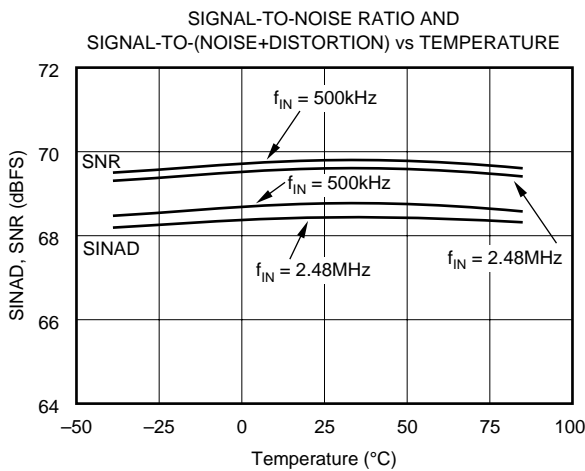
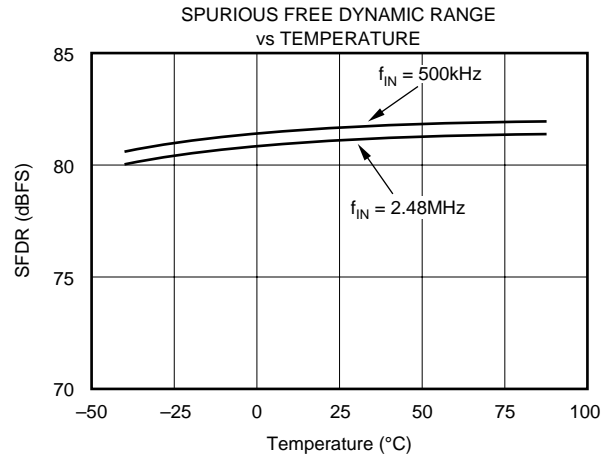
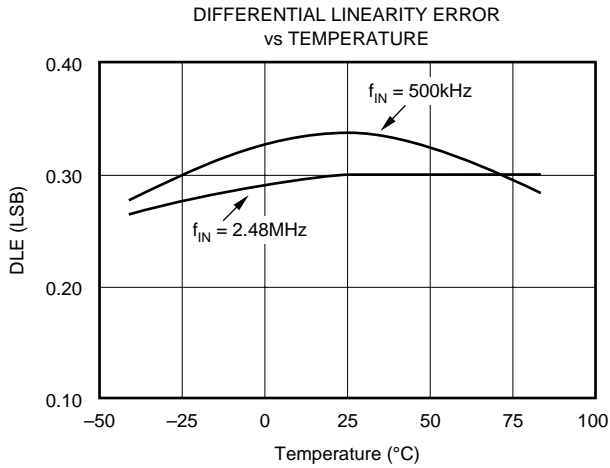
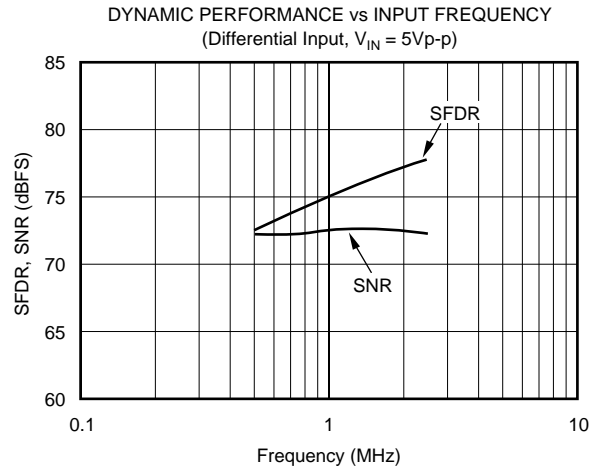
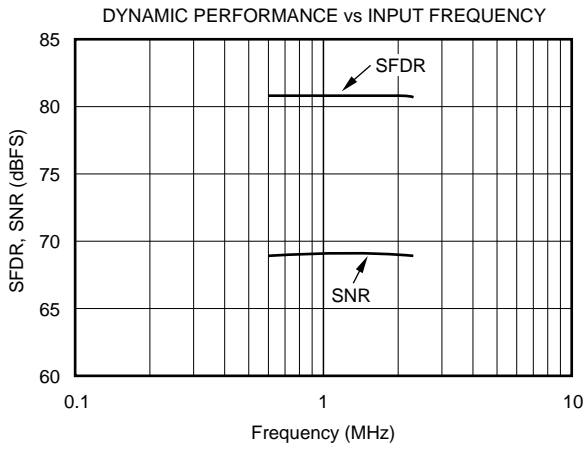

# TYPICAL PERFORMANCE CURVES

At  $T_A$  = full specified temperature range,  $V_S$  = +5V, specified input range = 1.5V to 3.5V, single-ended input and sampling rate = 5MHz, unless otherwise specified.

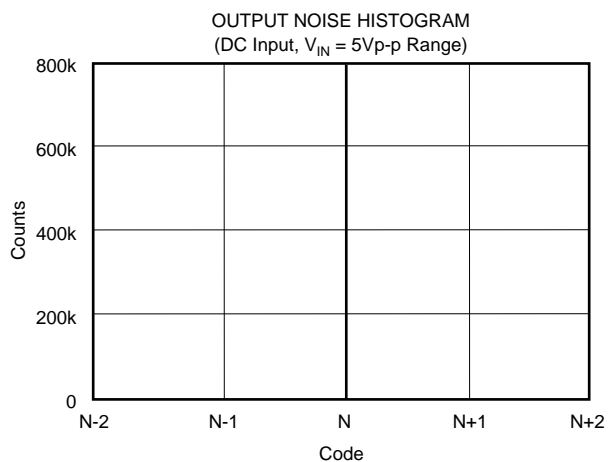
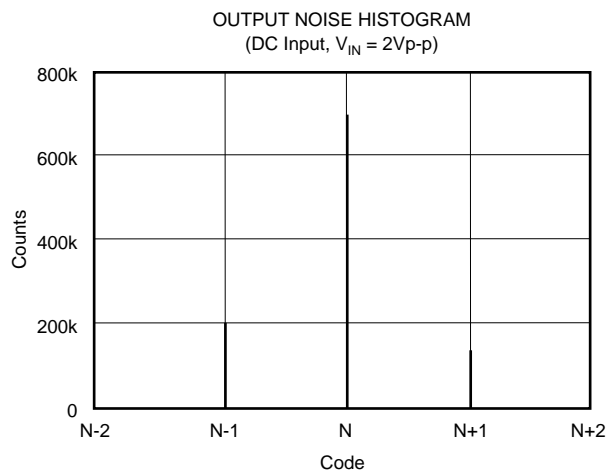

# APPLICATION INFORMATION

## DRIVING THE ANALOG INPUT

The ADS803 allows its analog inputs to be driven either single-ended or differentially. The focus of the following discussion is on the single-ended configuration. Typically, its implementation is easier to achieve and the rated specifications for the ADS803 are characterized using the single-ended mode of operation.

## AC-COUPLED INPUT CONFIGURATION

Given in Figure 1 is the circuit example of the most common interface configuration for the ADS803. With the  $V_{REF}$  pin connected to the SEL pin, the full-scale input range is defined to be 2Vp-p. This signal is ac-coupled in single-ended form to the ADS803 using the low-distortion voltage feedback amplifier OPA642. As is generally necessary for single-supply components, operating the ADS803 with a full-scale input signal swing requires a level-shift of the amplifier's zero centered analog signal to comply with the A/D's input range requirements. Using a DC blocking capacitor between the output of the driving amplifier and the converter's input, a simple level-shifting scheme can be implemented. In this configuration, the top and bottom references (REFT, REFB) provide an output voltage of +3V and +2V, respectively. Here, two resistor pairs (2x 2k $\Omega$ ) are used to create a common-mode voltage of approximately +2.5V to bias the inputs of the ADS803 ( $IN$ ,  $\overline{IN}$ ) to the required DC voltage.

An advantage of ac-coupling is that the driving amplifier still operates with a ground-based signal swing. This will keep the distortion performance at its optimum since the signal swing stays within the linear region of the op amp and sufficient headroom to the supply rails can be maintained. Consider using the inverting gain configuration to eliminate CMR induced errors of the amplifier. The addition of a small series resistor ( $R_S$ ) between the output of the op amp and the

input of the ADS803 will be beneficial in almost all interface configurations. This will de-couple the op amp's output from the capacitive load and avoid gain peaking, which can result in increased noise. For best spurious and distortion performance, the resistor value should be kept below 50 $\Omega$ . Furthermore, the series resistor together with the 100pF capacitor, establish a passive low-pass filter, limiting the bandwidth for the wideband noise thus help improving the SNR performance.

## DC-COUPLED WITHOUT LEVEL SHIFT

In some applications the analog input signal may already be biased at a level which complies with the selected input range and reference level of the ADS803. In this case, it is only necessary to provide an adequately low source impedance to the selected input,  $IN$  or  $\overline{IN}$ . Always consider wideband op amps since their output impedance will stay low over a wide range of frequencies. For those applications requiring the driving amplifier to provide a signal amplification, with a gain  $\geq 3$ , consider using the decompensated voltage feedback op amp OPA643.

## DC-COUPLED WITH LEVEL SHIFT

Several applications may require that the bandwidth of the signal path includes DC, in which case the signal has to be DC-coupled to the A/D converter. In order to accomplish this, the interface circuit has to provide a DC-level shift. The circuit shown in Figure 2 employs an op amp, A1, to sum the ground centered input signal with a required DC offset. The ADS803 typically operates with a +2.5V common-mode voltage, which is established at the center tap of the ladder and connected to the  $\overline{IN}$  input of the converter. Amplifier A1 operates in inverting configuration. Here resistors  $R_1$  and  $R_2$  set the DC-bias level for A1. Because of the op amp's noise gain of +2V/V, assuming  $R_F = R_{IN}$ , the DC offset voltage applied to its non-inverting input has to be divided down to +1.25V, resulting in a DC output voltage of +2.5V.

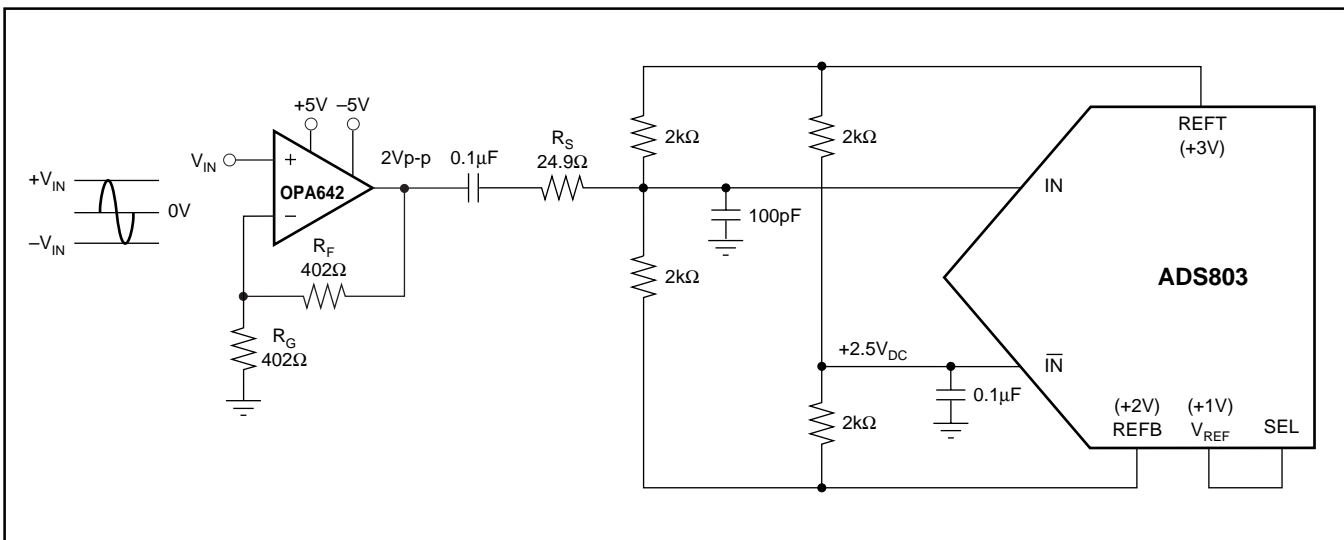

FIGURE 1. AC-Coupled Input Configuration for 2Vp-p Input Swing and Common-Mode Voltage at +2.5V Derived from Internal Top and Bottom Reference.

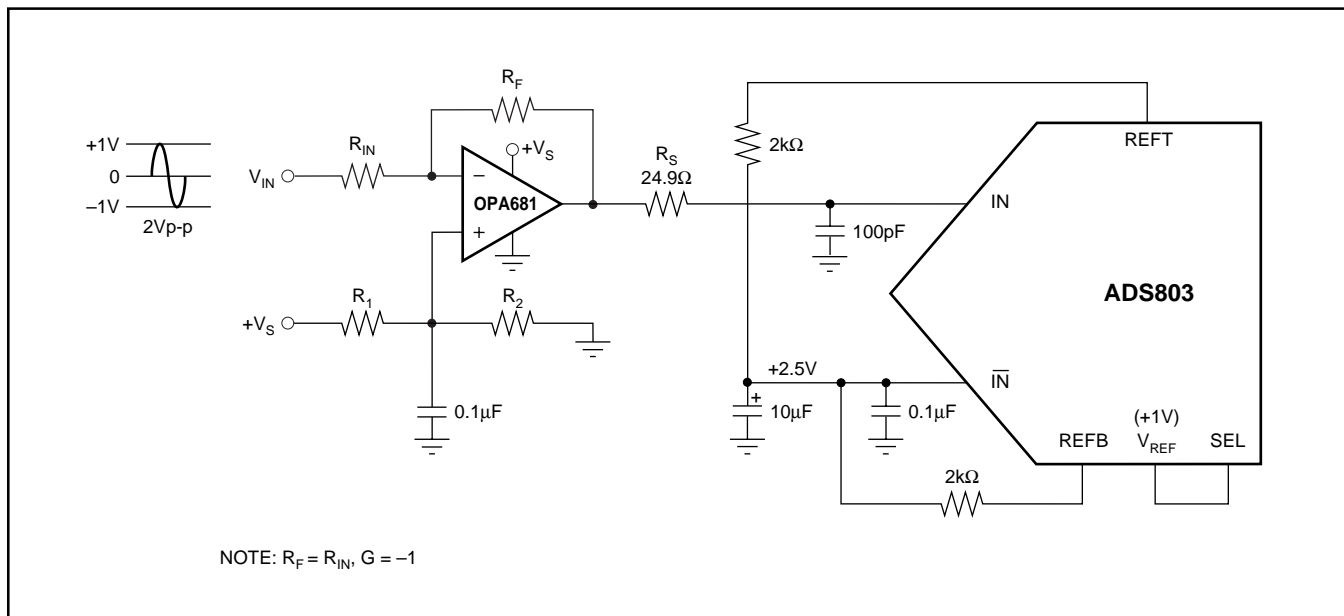

FIGURE 2. DC-Coupled, Single-Ended Input Configuration with DC-Level Shift.

DC voltage differences between the IN and  $\overline{IN}$  inputs of the ADS803 effectively will produce an offset, which can be corrected for by adjusting the values of resistors  $R_1$  and  $R_2$ . The bias current of the op amp may also result in an undesired offset. The selection criteria of the appropriate op amp should include the input bias current, output voltage swing, distortion and noise specification. Note that in this example the overall signal phase is inverted. To re-establish the original signal polarity it is always possible to interchange the IN and  $\overline{IN}$  connections.

### SINGLE-ENDED-TO-DIFFERENTIAL CONFIGURATION (TRANSFORMER COUPLED)

In order to select the best suited interface circuit for the ADS803, the performance requirements must be known. If an ac-coupled input is needed for a particular application, the next step is to determine the method of applying the signal; either single-ended or differentially. The differential input configuration may provide a noticeable advantage of achieving good SFDR performance based on the fact that in the differential mode the signal swing can be reduced to half of the swing required for single-ended drive. Secondly, by driving the ADS803 differentially, the even-order harmonics will be reduced. Figure 3 shows the schematic for the suggested transformer coupled interface circuit. The resistor across the secondary side ( $R_T$ ) should be set to get an input impedance match (e.g.,  $R_T = n^2 \cdot R_G$ ).

### REFERENCE OPERATION

Integrated into the ADS803 is a bandgap reference circuit including logic that provides either a +1V or +2.5V reference output, by simply selecting the corresponding pin-strap configuration. Different reference voltages can be generated by the use of two external resistors, which will set a different

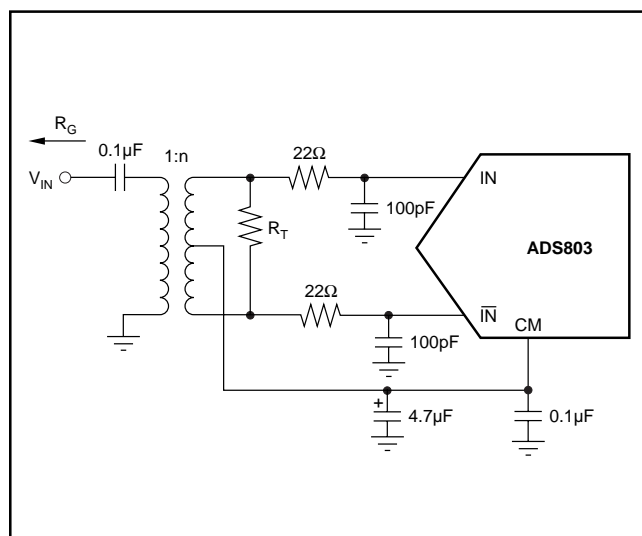

FIGURE 3. Transformer Coupled Input

gain for the internal reference buffer. For more design flexibility, the internal reference can be shut off and an external reference voltage used. Table I provides an overview of the possible reference options and pin configurations.

MODE	INPUT FULL-SCALE RANGE	REQUIRED $V_{REF}$	CONNECT	TO
Internal	2Vp-p	+1V	SEL	$V_{REF}$
Internal	5Vp-p	+2.5V	SEL	GND
Internal	$2V \leq FSR < 5V$ $FSR = 2 \times V_{REF}$	$1V < V_{REF} < 2.5V$ $V_{REF} = 1 + (R_1/R_2)$	$R_1$ $R_2$	$V_{REF}$ and SEL SEL and GND
External	$1V < FSR < 5V$	$0.5V < V_{REF} < 2.5V$	SEL $V_{REF}$	$+V_S$ Ext. $V_{REF}$

TABLE I. Selected Reference Configuration Examples.

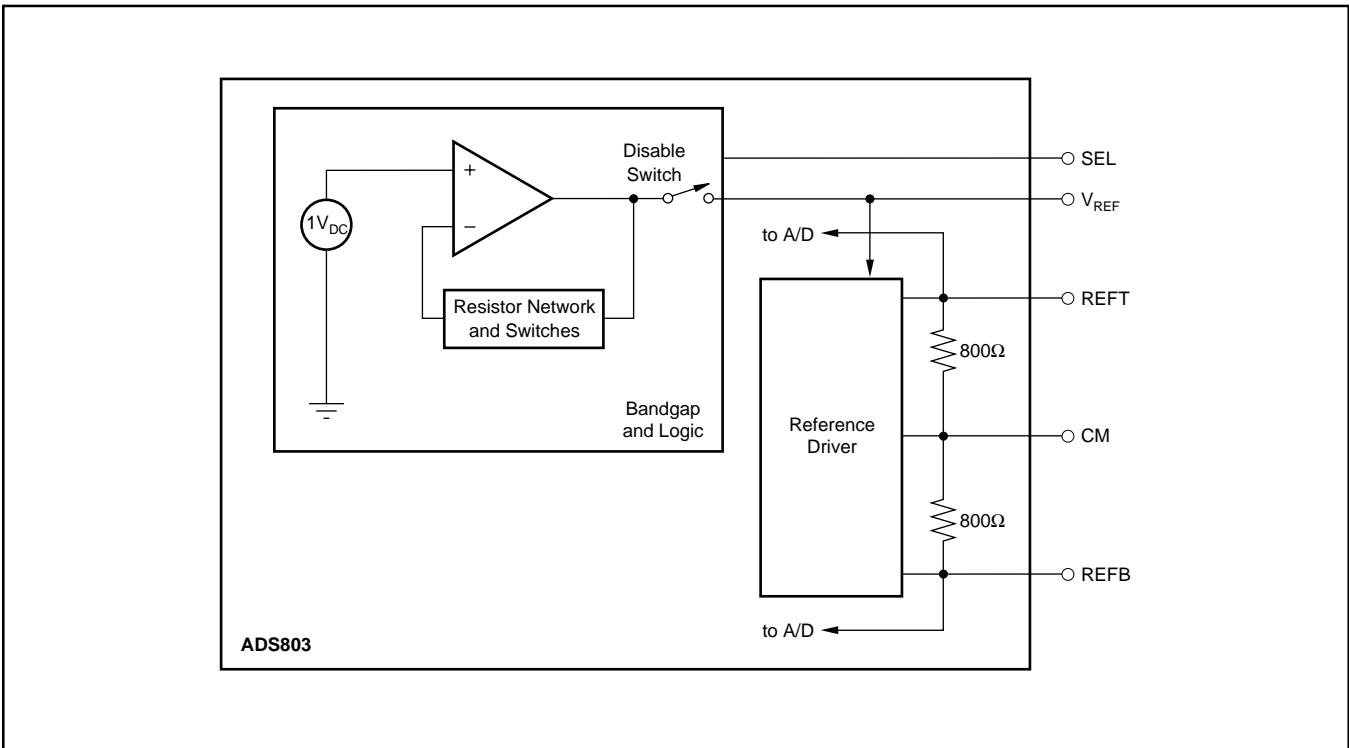

FIGURE 4. Equivalent Reference Circuit.

A simple model of the internal reference circuit is shown in Figure 4. The internal blocks are a 1V-bandgap voltage reference, buffer, the resistive reference ladder and the drivers for the top and bottom reference which supply the necessary current to the internal nodes. As shown, the output of the buffer appears at the  $V_{REF}$  pin. The full-scale input span of the ADS803 is determined by the voltage at  $V_{REF}$ , according to the equation (1):

$$\text{Full-Scale Input Span} = 2 \times V_{REF} \quad (1)$$

Note that the current drive capability of this amplifier is limited to approximately 1mA and should not be used to drive low loads. The programmable reference circuit is controlled by the voltage applied to the select pin (SEL). Refer to Table I for an overview.

The top reference (REFT) and the bottom reference (REFB) are brought out mainly for external bypassing. For proper

operation with all reference configurations, it is necessary to provide solid bypassing to the reference pins in order to keep the clock feedthrough to a minimum. Figure 5 shows the recommended decoupling network.

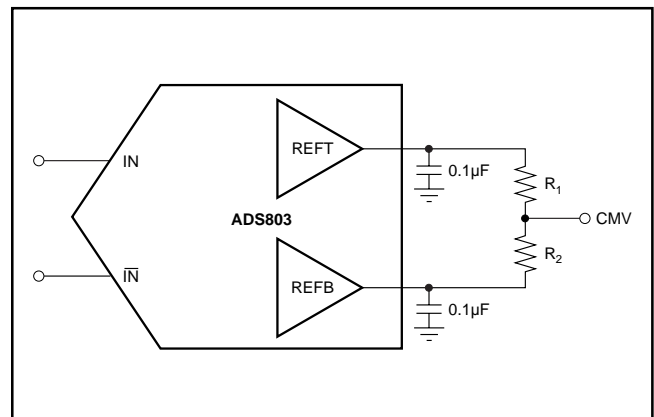

FIGURE 6. Alternative Circuit to Generate CM Voltage.

In addition, the common-mode voltage (CMV) may be used as a reference level to provide the appropriate offset for the driving circuitry. However, care must be taken not to appreciably load this node, which is not buffered and has a high impedance. An alternate method of generating a common-mode voltage is given in Figure 6. Here, two external precision resistors (tolerance 1% or better) are located between the top and bottom reference pins. The common-mode level will appear at the midpoint. The output buffers of the top and bottom reference are designed to supply approximately 2mA of output current.

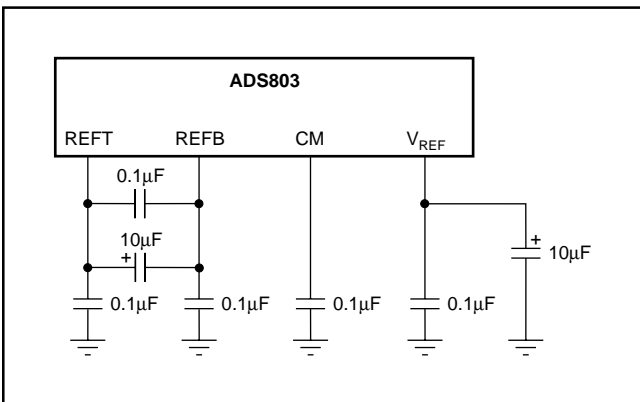

FIGURE 5. Recommended Reference Bypassing Scheme.

## SELECTING THE INPUT RANGE AND REFERENCE

Figures 7 through 9 show a selection of circuits for the most common input ranges when using the internal reference of the ADS803. All examples are for single-ended input and operate with a nominal common-mode voltage of +2.5V.

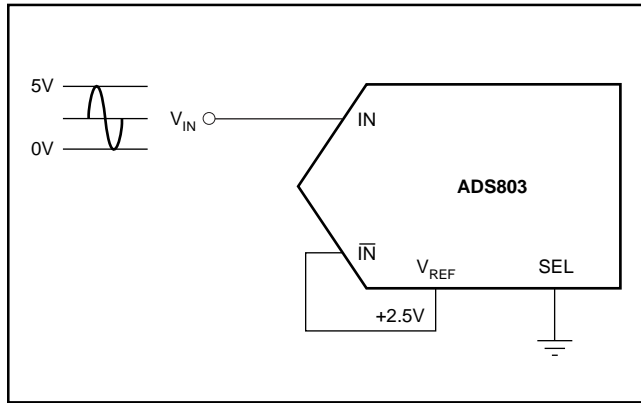

FIGURE 7. Internal Reference with 0V to 5V Input Range.

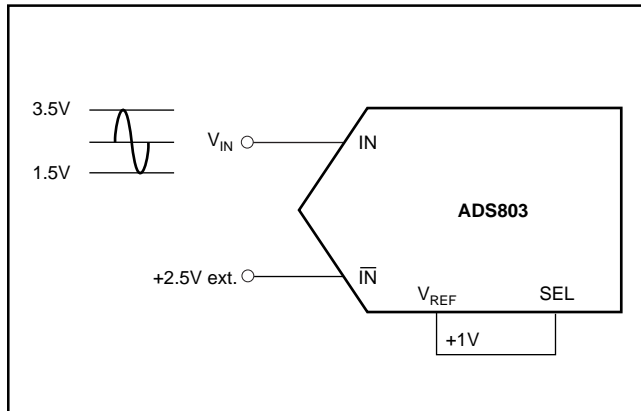

FIGURE 8. Internal Reference with 1.5V to 3.5V Input Range.

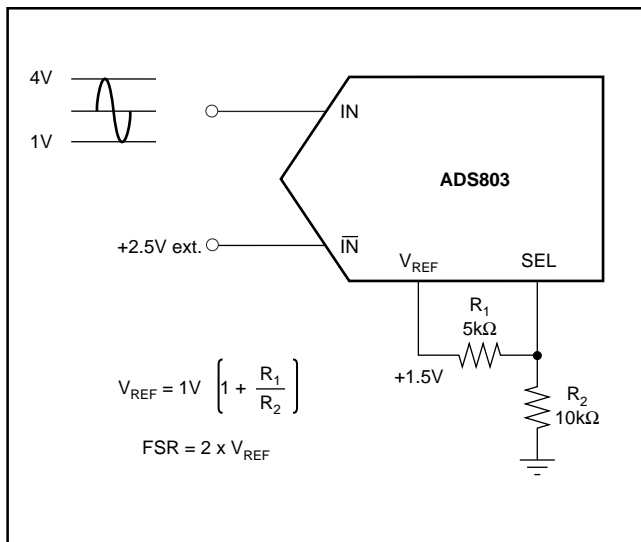

FIGURE 9. Internal Reference with 1V to 4V Input Range.

## EXTERNAL REFERENCE OPERATION

Depending on the application requirements, it might be advantageous to operate the ADS803 with an external reference. This may improve the DC accuracy if the external reference circuitry is superior in its drift and accuracy. To use the ADS803 with an external reference, the user must disable the internal reference (see Figure 10). By connecting the SEL pin to +V<sub>S</sub>, the internal logic will shut down the internal reference. At the same time, the output of the internal reference buffer is disconnected from the V<sub>REF</sub> pin, which now must be driven with the external reference. Note that a similar bypassing scheme should be maintained as described for the internal reference operation.

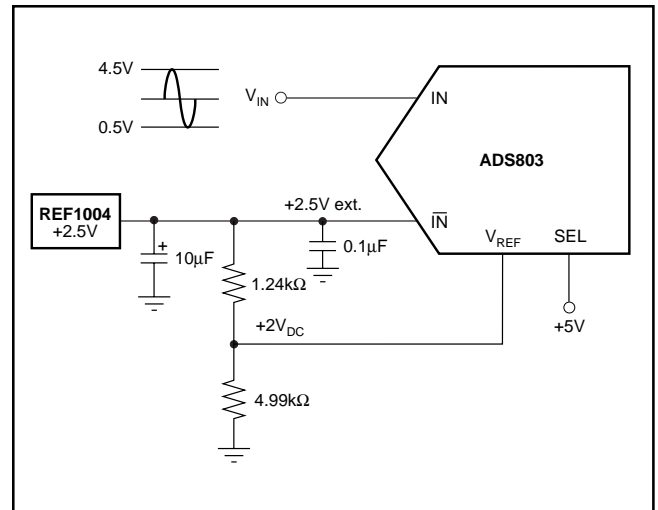

FIGURE 10. External Reference, Input Range 0.5V to 4.5V (4Vp-p), with +2.5V Common-Mode Voltage.

## DIGITAL INPUTS AND OUTPUTS

### Over Range (OVR)

One feature of the ADS803 is its ‘Over Range’ digital output (OVR). This pin can be used to monitor any out-of-range condition, which occurs every time the applied analog input voltage exceeds the input range (set by V<sub>REF</sub>). The OVR output is LOW when the input voltage is within the defined input range. It becomes HIGH when the input voltage is beyond the input range. This is the case when the input voltage is either below the bottom reference voltage or above the top reference voltage. OVR will remain active until the analog input returns to its normal signal range and another conversion is completed. Using the MSB and its complement in conjunction with OVR, a simple clue logic can be built that detects the overrange and underrange conditions (see Figure 11). It should be noted that OVR is a digital output which is updated along with the bit information corresponding to the particular sampling incidence of the analog signal. Therefore, the OVR data is subject to the same pipeline delay (latency) as the digital data.

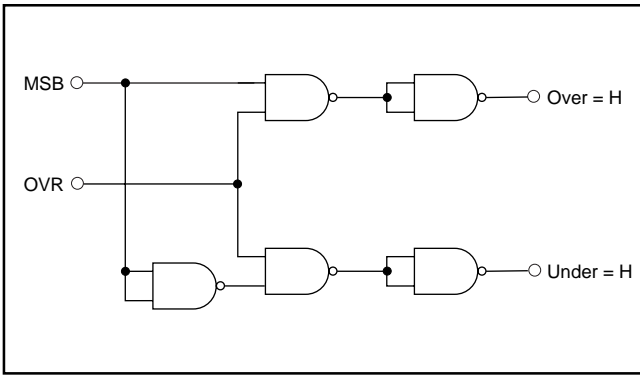

FIGURE 11. External Logic for Decoding Under- and Overrange Conditions.

### CLOCK INPUT REQUIREMENTS

Clock jitter is critical to the SNR performance of high speed, high resolution analog-to-digital converters. It leads to aperture jitter ( $t_A$ ) which adds noise to the signal being converted. The ADS803 samples the input signal on the rising edge of the CLK input. Therefore, this edge should have the lowest possible jitter. The jitter noise contribution to total SNR is given by the following equation. If this value is near your system requirements, input clock jitter must be reduced.

$$JitterSNR = 20 \log \frac{1}{2\pi f_{IN} t_A} \text{ rms signal to rms noise}$$

Where:  $f_{IN}$  is Input Signal Frequency

$t_A$  is rms Clock Jitter

Particularly in undersampling applications, special consideration should be given to clock jitter. The clock input should be treated as an analog input in order to achieve the highest level of performance. Any overshoot or undershoot of the clock signal may cause degradation of the performance. When digitizing at high sampling rates, the clock should have a 50% duty cycle ( $t_H = t_L$ ), along with fast rise and fall times of 2ns or less.

### DIGITAL OUTPUTS

The digital outputs of the ADS803 are designed to be compatible with both high speed TTL and CMOS logic families. The driver stage for the digital outputs is supplied through a separate supply pin, VDRV, which is not connected to the analog supply pins. By adjusting the voltage on VDRV, the digital output levels will vary respectively. Therefore, it is possible to operate the ADS803 on a +5V analog supply while interfacing the digital outputs to 3V logic.

It is recommended to keep the capacitive loading on the data lines as low as possible ( $\leq 15\text{pF}$ ). Larger capacitive loads demand higher charging currents as the outputs are changing. Those high current surges can feed back to the analog portion of the ADS803 and influence the performance. If

necessary, external buffers or latches may be used which provide the added benefit of isolating the ADS803 from any digital noise activities on the bus coupling back high frequency noise. In addition, resistors in series with each data line may help maintain the ac performance of the ADS803. Their use depends on the capacitive loading seen by the converter. Values in the range of  $100\Omega$  to  $200\Omega$  will limit the instantaneous current the output stage has to provide for recharging the parasitic capacitances, as the output levels change from L to H or H to L.

### GROUNDING AND DECOUPLING

Proper grounding and bypassing, short lead length, and the use of ground planes are particularly important for high frequency designs. Multi-layer PC boards are recommended for best performance since they offer distinct advantages like minimizing ground impedance, separation of signal layers by ground layers, etc. It is recommended that the analog and digital ground pins of the ADS803 be joined together at the IC and be connected only to the analog ground of the system.

The ADS803 has analog and digital supply pins, however, the converter should be treated as an analog component and all supply pins should be powered by the analog supply. This will ensure the most consistent results, since digital supply lines often carry high levels of noise that would otherwise be coupled into the converter and degrade the achievable performance.

Because of the pipeline architecture, the converter also generates high frequency current transients and noise that are fed back into the supply and reference lines. This requires that the supply and reference pins be sufficiently bypassed. Figure 12 shows the recommended decoupling scheme for the analog supplies. In most cases,  $0.1\mu\text{F}$  ceramic chip capacitors are adequate to keep the impedance low over a wide frequency range. Their effectiveness largely depends on the proximity to the individual supply pin. Therefore, they should be located as close to the supply pins as possible. In addition, a larger size bipolar capacitor (1 to  $22\mu\text{F}$ ) should be placed on the PC board in close proximity to the converter circuit.

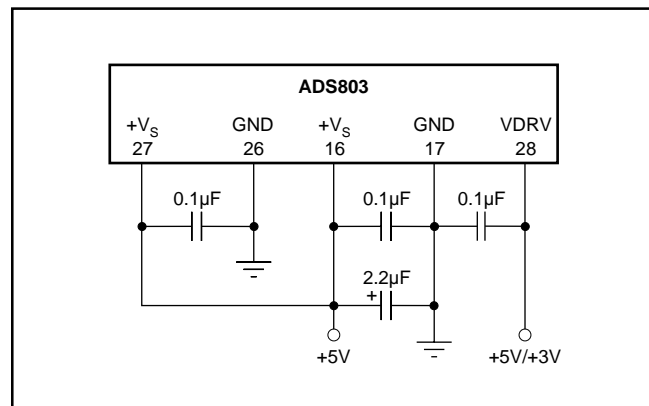

FIGURE 12. Recommended Bypassing for Analog Supply Pins.

This datasheet has been downloaded from:

[www.DatasheetCatalog.com](http://www.DatasheetCatalog.com)

Datasheets for electronic components.



LittleDiode supplies new, hard to find or obsolete electronic components and semiconductors all over the world.

With over two million different components listed you are sure to find the part you need.

Feel free to visit us today at our online store:

[LittleDiode.com](http://LittleDiode.com)

Looking forward to providing you with the best possible service.