

### SUMMARY

**16-Bit Fixed-Point DSP Microprocessors with On-Chip Memory**

**Enhanced Harvard Architecture for Three-Bus Performance: Instruction Bus and Dual Data Buses**  
**Independent Computation Units: ALU, Multiplier/Accumulator and Shifter**

**Single-Cycle Instruction Execution and Multifunction Instructions**

**On-Chip Program Memory ROM and Data Memory RAM**  
**Integrated I/O Peripherals: Serial Ports, Timer**

### FEATURES

**25 MIPS, 40 ns Maximum Instruction Rate (5 V)**  
**Separate On-Chip Buses for Program and Data Memory**  
**Program Memory Stores Both Instructions and Data (Three-Bus Performance)**

**Dual Data Address Generators with Modulo and Bit-Reverse Addressing**

**Efficient Program Sequencing with Zero-Overhead Looping: Single-Cycle Loop Setup**

**Double-Buffered Serial Ports with Companding Hardware, Automatic Data Buffering and Multichannel Operation**

**Three Edge- or Level-Sensitive Interrupts**

**Low Power IDLE Instruction**

**PLCC and MQFP Packages**

### GENERAL DESCRIPTION

The ADSP-216x Family processors are single-chip microcomputers optimized for digital signal processing (DSP) and other high speed numeric processing applications. The ADSP-216x processors are all built upon a common core with ADSP-2100. Each processor combines the core DSP architecture—computation units, data address generators and program sequencer—with features such as on-chip program ROM and data memory RAM, a programmable timer and two serial ports. The ADSP-2165/ADSP-2166 also adds program memory and power-down mode.

This data sheet describes the following ADSP-216x Family processors:

ADSP-2161/ADSP-2162/ ADSP-2163/ADSP-2164 ADSP-2165/ADSP-2166	<i>Custom ROM-programmed DSPs: ROM-programmed ADSP-216x processors with power-down and larger on-chip memories (12K Program Memory ROM, 1K Program Memory RAM, 4K Data Memory RAM)</i>
--	--

### REV. 0

Information furnished by Analog Devices is believed to be accurate and reliable. However, no responsibility is assumed by Analog Devices for its use, nor for any infringements of patents or other rights of third parties which may result from its use. No license is granted by implication or otherwise under any patent or patent rights of Analog Devices.

### FUNCTIONAL BLOCK DIAGRAM

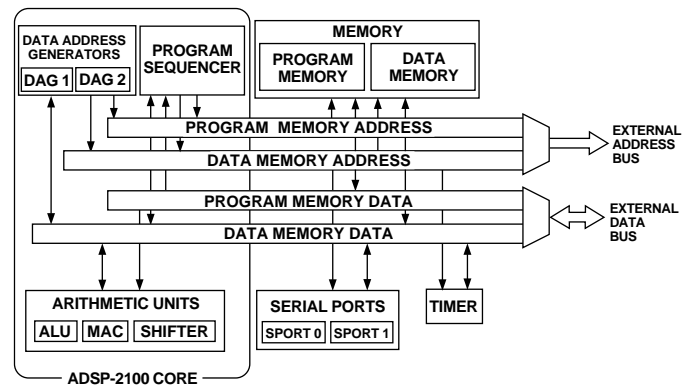

Fabricated in a high speed, submicron, double-layer metal CMOS process, the highest-performance ADSP-216x processors operate at 25 MHz with a 40 ns instruction cycle time. Every instruction can execute in a single cycle. Fabrication in CMOS results in low power dissipation.

The ADSP-2100 Family's flexible architecture and comprehensive instruction set support a high degree of parallelism. In one cycle the ADSP-216x can perform all of the following operations:

- Generate the next program address
- Fetch the next instruction
- Perform one or two data moves
- Update one or two data address pointers
- Perform a computation
- Receive and transmit data via one or two serial ports

Table I shows the features of each ADSP-216x processor.

The ADSP-216x series are memory-variant versions of the ADSP-2101 and ADSP-2103 that contain factory-programmed on-chip ROM program memory. These devices offer different amounts of on-chip memory for program and data storage. Table I shows the features available in the ADSP-216x series of custom ROM-coded processors.

The ADSP-216x products eliminate the need for an external boot EPROM in your system, and can also eliminate the need for any external program memory by fitting the entire application program in on-chip ROM. These devices thus provide an excellent option for volume applications where board space and system cost constraints are of critical concern.

# ADSP-216x

## TABLE OF CONTENTS

SUMMARY .....	1	TEST CONDITIONS .....	20
FEATURES .....	1	Output Disable Time .....	20
GENERAL DESCRIPTION .....	1	Output Enable Time .....	20
Development Tools .....	3	TIMING PARAMETERS	
Additional Information .....	3	(ADSP-2161/ADSP-2163/ADSP-2165) .....	21
ARCHITECTURE OVERVIEW .....	3	GENERAL NOTES .....	21
Serial Ports .....	4	TIMING NOTES .....	21
Interrupts .....	5	MEMORY REQUIREMENTS .....	21
SYSTEM INTERFACE .....	5	CLOCK SIGNALS AND RESET .....	22
Clock Signals .....	5	INTERRUPTS AND FLAGS .....	23
Reset .....	6	BUS REQUEST/BUS GRANT .....	24
PIN FUNCTION DESCRIPTIONS .....	6	MEMORY READ .....	25
Program Memory Interface .....	7	MEMORY WRITE .....	26
Program Memory Maps .....	7	SERIAL PORTS .....	27
Data Memory Interface .....	8	TIMING PARAMETERS	
Data Memory Map .....	8	(ADSP-2162/ADSP-2164/ADSP-2166) .....	28
Bus Interface .....	9	GENERAL NOTES .....	28
POWER-DOWN .....	9	TIMING NOTES .....	28
Power-Down Control .....	9	MEMORY REQUIREMENTS .....	28
Entering Power-Down .....	9	CLOCK SIGNALS AND RESET .....	29
Exiting Power-Down .....	10	INTERRUPTS AND FLAGS .....	30
Low Power IDLE Instruction .....	10	BUS REQUEST/BUS GRANT .....	31
ADSP-216x Prototyping .....	10	MEMORY READ .....	32
Ordering Procedure for ADSP-216x ROM Processors .....	10	MEMORY WRITE .....	33
Instruction Set .....	11	SERIAL PORTS .....	34
SPECIFICATIONS—RECOMMENDED OPERATING		PIN CONFIGURATIONS	
CONDITIONS		68-Lead PLCC (ADSP-216x) .....	35
(ADSP-2161/ADSP-2163/ADSP-2165) .....	13	80-Lead MQFP (ADSP-216x) .....	36
ELECTRICAL CHARACTERISTICS .....	13	PACKAGE OUTLINE DIMENSIONS	
ABSOLUTE MAXIMUM RATINGS .....	13	68-Lead PLCC .....	37
SPECIFICATIONS—SUPPLY CURRENT AND POWER		80-Lead MQFP .....	38
(ADSP-2161/ADSP-2163/ADSP-2165) .....	14	ORDERING GUIDE .....	39
POWER DISSIPATION EXAMPLE .....	15		
ENVIRONMENTAL CONDITIONS .....	15		
CAPACITIVE LOADING .....	15		
SPECIFICATIONS—			
(ADSP-2161/ADSP-2163/ADSP-2165) .....	16		
TEST CONDITIONS .....	16		
Output Disable Time .....	16		
Output Enable Time .....	16		
SPECIFICATIONS—RECOMMENDED OPERATING			
CONDITIONS			
(ADSP-2162/ADSP-2164/ADSP-2166) .....	17		
ELECTRICAL CHARACTERISTICS .....	17		
ABSOLUTE MAXIMUM RATINGS .....	17		
SPECIFICATIONS—SUPPLY CURRENT AND POWER			
(ADSP-2162/ADSP-2164/ADSP-2166) .....	18		
POWER DISSIPATION EXAMPLE .....	19		
ENVIRONMENTAL CONDITIONS .....	19		
CAPACITIVE LOADING .....	19		

**Table I. ADSP-216x ROM-Programmed Processor Features**

Feature	2161	2162	2163	2164	2165	2166
Data Memory (RAM)	1/2K	1/2K	1/2K	1/2K	4K	4K
Program Memory (ROM)	8K	8K	4K	4K	12K	12K
Program Memory (RAM)					1K	1K
Timer	•	•	•	•	•	•
Serial Port 0 (Multichannel)	•	•	•	•	•	•
Serial Port 1	•	•	•	•	•	•
Supply Voltage	5 V	3.3 V	5 V	3.3 V	5 V	3.3 V
Speed Grades ( <i>Instruction Cycle Time</i> )						
10.24 MHz ( <i>97.6 ns</i> )		•		•		
13.00 MHz ( <i>76.9 ns</i> )						•
16.67 MHz ( <i>60 ns</i> )	•		•			•
20.00 MHz ( <i>50 ns</i> )					•	
25 MHz ( <i>40 ns</i> )			•		•	
Packages						
68-Lead PLCC	•	•	•	•		
80-Lead MQFP	•	•	•	•	•	•
Temperature Grades						
K <i>Commercial</i> , 0°C to +70°C	•	•	•	•	•	•
B <i>Industrial</i> , -40°C to +85°C	•	•	•	•	•	•

### Development Tools

The ADSP-216x processors are supported by a complete set of tools for system development. The ADSP-2100 Family Development Software includes C and assembly language tools that allow programmers to write code for any of the ADSP-216x processors. The ANSI C compiler generates ADSP-216x assembly source code, while the runtime C library provides ANSI-standard and custom DSP library routines. The ADSP-216x assembler produces object code modules that the linker combines into an executable file. The processor simulators provide an interactive instruction-level simulation with a reconfigurable, windowed user interface. A PROM splitter utility generates PROM programmer compatible files.

EZ-ICE® in-circuit emulators allow debugging of ADSP-21xx systems by providing a full range of emulation functions such as modification of memory and register values and execution breakpoints. EZ-LAB® demonstration boards are complete DSP systems that execute EPROM-based programs.

The EZ-Kit Lite is a very low-cost evaluation/development platform that contains both the hardware and software needed to evaluate the ADSP-21xx architecture.

Additional details and ordering information are available in the *ADSP-2100 Family Software & Hardware Development Tools* data sheet (ADDS-21xx-TOOLS). This data sheet can be requested from any Analog Devices sales office or distributor.

### Additional Information

This data sheet provides a general overview of ADSP-216x processor functionality. For detailed design information on the architecture and instruction set, refer to the *ADSP-2100 Family User's Manual*, Third Edition, available from Analog Devices.

### ARCHITECTURE OVERVIEW

Figure 1 shows a block diagram of the ADSP-216x architecture. The processors contain three independent computational units: the ALU, the multiplier/accumulator (MAC), and the shifter. The computational units process 16-bit data directly and have provisions to support multiprecision computations. The ALU performs a standard set of arithmetic and logic operations; division primitives are also supported. The MAC performs single-cycle multiply, multiply/add, and multiply/subtract operations. The shifter performs logical and arithmetic shifts, normalization, denormalization, and derive exponent operations. The shifter can be used to efficiently implement numeric format control including multiword floating-point representations.

The internal result (R) bus directly connects the computational units so that the output of any unit may be used as the input of any unit on the next cycle.

A powerful program sequencer and two dedicated data address generators ensure efficient use of these computational units. The sequencer supports conditional jumps, subroutine calls, and returns in a single cycle. With internal loop counters and loop stacks, the ADSP-216x executes looped code with zero overhead—no explicit jump instructions are required to maintain the loop.

Two data address generators (DAGs) provide addresses for simultaneous dual operand fetches (from data memory and program memory). Each DAG maintains and updates four address pointers. Whenever the pointer is used to access data (indirect addressing), it is post-modified by the value of one of four modify registers. A length value may be associated with each pointer to implement automatic modulo addressing for circular buffers. The circular buffering feature is also used by the serial ports for automatic data transfers to (and from) on-chip memory.



The ADSP-216x serial ports offer the following capabilities:

**Bidirectional**—Each SPORT has a separate, double-buffered transmit and receive function.

**Flexible Clocking**—Each SPORT can use an external serial clock or generate its own clock internally.

**Flexible Framing**—The SPORTs have independent framing for the transmit and receive functions; each function can run in a frameless mode or with frame synchronization signals internally generated or externally generated; frame sync signals may be active high or inverted, with either of two pulsewidths and timings.

**Different Word Lengths**—Each SPORT supports serial data word lengths from 3 to 16 bits.

**Companding in Hardware**—Each SPORT provides optional A-law and  $\mu$ -law companding according to CCITT recommendation G.711.

**Flexible Interrupt Scheme**—Receive and transmit functions can generate a unique interrupt upon completion of a data word transfer.

**Autobuffering with Single-Cycle Overhead**—Each SPORT can automatically receive or transmit the contents of an entire circular data buffer with only one overhead cycle per data word; an interrupt is generated after the transfer of the entire buffer is completed.

**Multichannel Capability (SPORT0 Only)**—SPORT0 provides a multichannel interface to selectively receive or transmit a 24-word or 32-word, time-division multiplexed serial bit stream; this feature is especially useful for T1 or CEPT interfaces, or as a network communication scheme for multiple processors.

**Alternate Configuration**—SPORT1 can be alternatively configured as two external interrupt inputs ( $\overline{IRQ0}$ ,  $\overline{IRQ1}$ ) and the Flag In and Flag Out signals (FI, FO).

### Interrupts

The ADSP-216x's interrupt controller lets the processor respond to interrupts with a minimum of overhead. Up to three external interrupt input pins,  $\overline{IRQ0}$ ,  $\overline{IRQ1}$  and  $\overline{IRQ2}$ , are provided.  $\overline{IRQ2}$  is always available as a dedicated pin;  $\overline{IRQ1}$  and  $\overline{IRQ0}$  may be alternately configured as part of Serial Port 1. The ADSP-216x also supports internal interrupts from the timer and the serial ports. The interrupts are internally prioritized and individually maskable (except for  $\overline{RESET}$  which is nonmaskable). The  $\overline{IRQx}$  input pins can be programmed for either level- or edge-sensitivity. The interrupt priorities for each ADSP-216x processor are shown in Table II.

**Table II. Interrupt Vector Addresses and Priority**

ADSP-216x Interrupt Source	Interrupt Vector Address
$\overline{RESET}$ Startup	0x0000
$\overline{IRQ2}$ or Power-Down	0x0004 ( <i>High Priority</i> )
SPORT0 Transmit	0x0008
SPORT0 Receive	0x000C
SPORT1 Transmit or $\overline{IRQ1}$	0x0010
SPORT1 Receive or $\overline{IRQ0}$	0x0014
Timer	0x0018 ( <i>Low Priority</i> )

The ADSP-216x uses a vectored interrupt scheme: when an interrupt is acknowledged, the processor shifts program control to the interrupt vector address corresponding to the interrupt received. Interrupts can be optionally nested so that a higher priority interrupt can preempt the currently executing interrupt service routine. Each interrupt vector location is four instructions in length so that simple service routines can be coded entirely in this space. Longer service routines require an additional JUMP or CALL instruction.

Individual interrupt requests are logically ANDed with the bits in the IMASK register; the highest-priority unmasked interrupt is then selected.

The interrupt control register,  $\overline{ICNTL}$ , allows the external interrupts to be set as either edge- or level-sensitive. Depending on Bit 4 in  $\overline{ICNTL}$ , interrupt service routines can either be nested (with higher priority interrupts taking precedence) or be processed sequentially (with only one interrupt service active at a time).

The interrupt force and clear register, IFC, is a write-only register that contains a force bit and a clear bit for each interrupt.

When responding to an interrupt, the ASTAT, MSTAT and IMASK status registers are pushed onto the status stack and the PC counter is loaded with the appropriate vector address. The status stack is seven levels deep to allow interrupt nesting. The stack is automatically popped when a return from the interrupt instruction is executed.

### Pin Definitions

Pin Function Descriptions show pin definitions for the ADSP-216x processors. Any inputs not used must be tied to  $V_{DD}$ .

### SYSTEM INTERFACE

Figure 3 shows a typical system for the ADSP-216x with two serial I/O devices, an optional external program and data memory. A total of 12K words of data memory and 15K words of program memory is addressable.

Programmable wait-state generation allows the processors to easily interface to slow external memories.

The ADSP-216x processors also provide either: one external interrupt ( $\overline{IRQ2}$ ) and two serial ports (SPORT0, SPORT1), or three external interrupts ( $\overline{IRQ2}$ ,  $\overline{IRQ1}$ ,  $\overline{IRQ0}$ ) and one serial port (SPORT0).

### Clock Signals

The ADSP-216x processors' CLKIN input may be driven by a crystal or by a TTL-compatible external clock signal. The CLKIN input may not be halted or changed in frequency during operation, nor operated below the specified low frequency limit.

If an external clock is used, it should be a TTL-compatible signal running at the instruction rate. The signal should be connected to the processor's CLKIN input; in this case, the XTAL input must be left unconnected.

Because the ADSP-216x processors include an on-chip oscillator circuit, an external crystal may also be used. The crystal should be connected across the CLKIN and XTAL pins, with two capacitors connected as shown in Figure 2. A parallel-resonant, fundamental frequency, microprocessor-grade crystal should be used.

# ADSP-216x

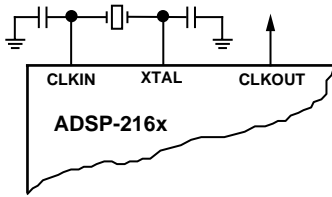

Figure 2. External Crystal Connections

A clock output signal (CLKOUT) is generated by the processor, synchronized to the processor's internal cycles.

## Reset

The  $\overline{\text{RESET}}$  signal initiates a complete reset of the ADSP-216x. The  $\overline{\text{RESET}}$  signal must be asserted when the chip is powered up to assure proper initialization. If the  $\overline{\text{RESET}}$  signal is applied during initial power-up, it must be held long enough to allow the processor's internal clock to stabilize. If  $\overline{\text{RESET}}$  is activated at any time after power-up and the input clock frequency does not change, the processor's internal clock continues and does not require this stabilization time.

The power-up sequence is defined as the total time required for the crystal oscillator circuit to stabilize after a valid  $V_{DD}$  is applied to the processor and for the internal phase-locked loop (PLL) to lock onto the specific crystal frequency. A minimum of 2000  $t_{CK}$  cycles will ensure that the PLL has locked (this does not, however, include the crystal oscillator start-up time). During this power-up sequence the  $\overline{\text{RESET}}$  signal should be held low. On any subsequent resets, the  $\overline{\text{RESET}}$  signal must meet the minimum pulsewidth specification,  $t_{RSP}$ .

To generate the  $\overline{\text{RESET}}$  signal, use either an RC circuit with an external Schmidt trigger or a commercially available reset IC. (Do not use only an RC circuit.)

The  $\overline{\text{RESET}}$  input resets all internal stack pointers to the empty stack condition, masks all interrupts, and clears the MSTAT register. When  $\overline{\text{RESET}}$  is released, the boot loading sequence is performed (provided there is no pending bus request and the chip is configured for booting, with  $\text{MMAP} = 0$ ). The first instruction is then fetched from internal program memory location 0x0000.

## PIN FUNCTION DESCRIPTIONS

Pin Name(s)	# of Pins	Input/Output	Function
Address	14	O	Address outputs for program, data and boot memory.
Data <sup>1</sup>	24	I/O	Data I/O pins for program and data memories. Input only for boot memory, with two MSBs used for boot memory addresses. Unused data lines may be left floating.
$\overline{\text{RESET}}$	1	I	Processor Reset Input
$\overline{\text{IRQ2}}$	1	I	External Interrupt Request #2
$\overline{\text{BR}}^2$	1	I	External Bus Request Input
$\overline{\text{BG}}$	1	O	External Bus Grant Output
$\overline{\text{PMS}}$	1	O	External Program Memory Select
$\overline{\text{DMS}}$	1	O	External Data Memory Select
$\overline{\text{BMS}}$	1	O	Boot Memory Select
$\overline{\text{RD}}$	1	O	External Memory Read Enable
$\overline{\text{WR}}$	1	O	External Memory Write Enable
MMAP	1	I	Memory Map Select Input
CLKIN, XTAL	2	I	External Clock or Quartz Crystal Input
CLKOUT	1	O	Processor Clock Output
$V_{DD}$			Power Supply Pins
GND			Ground Pins
SPORT0	5	I/O	Serial Port 0 Pins ( $TFS0$ , $RFS0$ , $DT0$ , $DR0$ , $SCLK0$ )
SPORT1	5	I/O	Serial Port 1 Pins ( $TFS1$ , $RFS1$ , $DT1$ , $DR1$ , $SCLK1$ )
or Interrupts and Flags:			
$\overline{\text{IRQ0}}$ ( $RFS1$ )	1	I	External Interrupt Request #0
$\overline{\text{IRQ1}}$ ( $TFS1$ )	1	I	External Interrupt Request #1
FI ( $DR1$ )	1	I	Flag Input Pin
FO ( $DT1$ )	1	O	Flag Output Pin
PWDACK <sup>3</sup>	1	O	Indicates when the processor has entered power-down.
PWDFLAG <sup>3</sup>	1	I	Low-to-High Transition of the Power-Down Flag. Input pin can be used to terminate power-down.

## NOTES

<sup>1</sup>Unused data bus lines may be left floating.

<sup>2</sup> $\overline{\text{BR}}$  must be tied high (to  $V_{DD}$ ) if not used.

<sup>3</sup>Only on ADSP-2165/ADSP-2166.

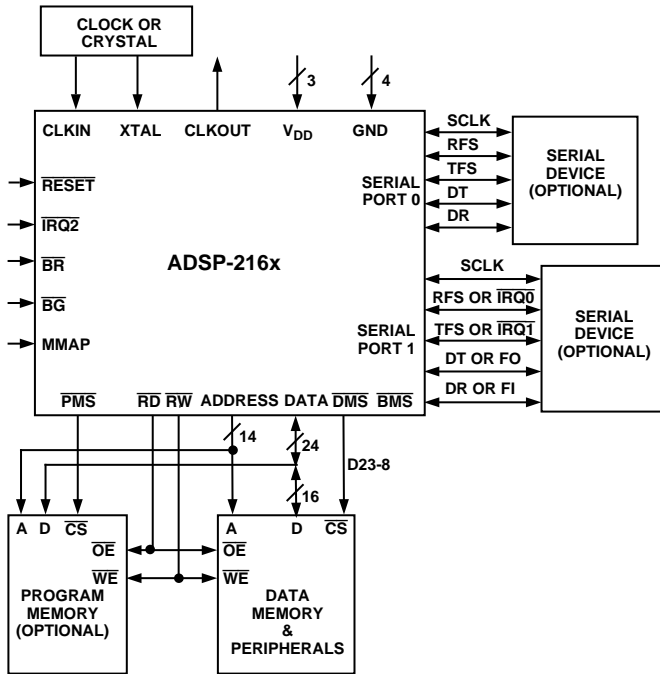

Figure 3. Basic System Configuration

### Program Memory Interface

The on-chip program memory address bus (PMA) and on-chip program memory data bus (PMD) are multiplexed with the on-chip data memory buses (DMA, DMD), creating a single external data bus and a single external address bus. The external data bus is bidirectional and is 24 bits wide to allow instruction fetches from external program memory. Program memory may contain code and data.

The external address bus is 14 bits wide. For the ADSP-216x, these lines can directly address up to 16K words, of which 2K are on-chip.

The data lines are bidirectional. The program memory select ( $\overline{PMS}$ ) signal indicates accesses to program memory and can be used as a chip select signal. The write ( $\overline{WR}$ ) signal indicates a write operation and is used as a write strobe. The read ( $\overline{RD}$ ) signal indicates a read operation and is used as a read strobe or output enable signal.

The ADSP-216x processors write data from their 16-bit registers to 24-bit program memory using the PX register to provide the lower eight bits. When the processor reads 16-bit data from 24-bit program memory to a 16-bit data register, the lower eight bits are placed in the PX register.

The program memory interface can generate 0 to 7 wait states for external memory devices; default is to 7 wait states after  $\overline{RESET}$ .

### Program Memory Maps

Program memory can be mapped in two ways, depending on the state of the MMAP pin. Figure 4 shows the program memory map for the ADSP-2165/ADSP-2166. Figures 5 and 6 show the program memory maps for the ADSP-2161/ADSP-2162 and ADSP-2163/ADSP-2164, respectively.

### ADSP-2165/ADSP-2166

When MMAP = 0, on-chip program memory ROM occupies 12K words beginning at address 0x0000. Internal program memory RAM occupies 1K words beginning at address 0x3000. Off-chip program memory uses the 2K words beginning at address 0x3800. The ADSP-2165/ADSP-2166 does not support boot memory.

When MMAP = 1, 2K words of off-chip program memory begin at address 0x0000. 10K words of on-chip program memory ROM at 0x800 to 0x2FFF, and the remainder 2K words of program memory ROM is at 0x3800 to 0x3FFF. Internal program memory RAM occupies 1K words at address 0x300 to 0x33FF.

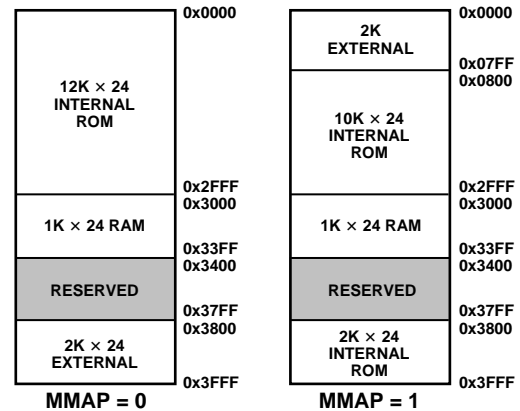

Figure 4. ADSP-2165/ADSP-2166 Program Memory Maps

### ADSP-2161/ADSP-2162

When MMAP = 0, on-chip program memory ROM occupies 8K words beginning at address 0x0000. Off-chip program memory uses the remaining 8K words beginning at address 0x2000.

When MMAP = 1, 2K words of off-chip program memory begin at address 0x0000. 6K words of on-chip program memory ROM are at 0x0800 to 0x1FF0, and the remainder 2K words of program memory ROM is at 0x3800 to 0x3FFF. An additional 6K of off-chip program memory is at 0x2000 to 0x37FF.

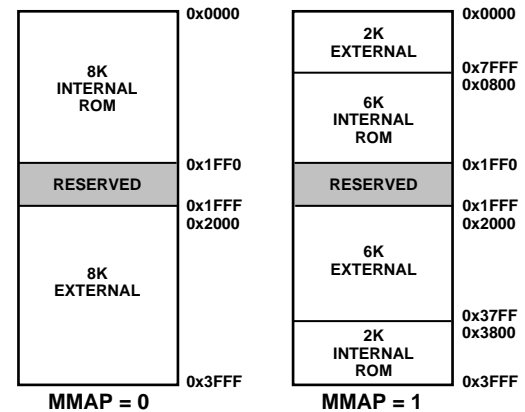

Figure 5. ADSP-2161/ADSP-2162 Program Memory Maps

# ADSP-216x

## ADSP-2163/ADSP-2164

When MMAP = 0, on-chip program memory ROM occupies 4K words beginning at address 0x0000. Off-chip program memory uses the remaining 12K words beginning at address 0x1000.

When MMAP = 1, 2K words of off-chip program memory begin at address 0x0000. 2K words of on-chip program memory ROM is at 0x0800 to 0x0FF0, and the remainder 2K words of program memory ROM is at 0x3800 to 0x3FFF. An additional 10K of off-chip program memory is at 0x1000 to 0x37FF.

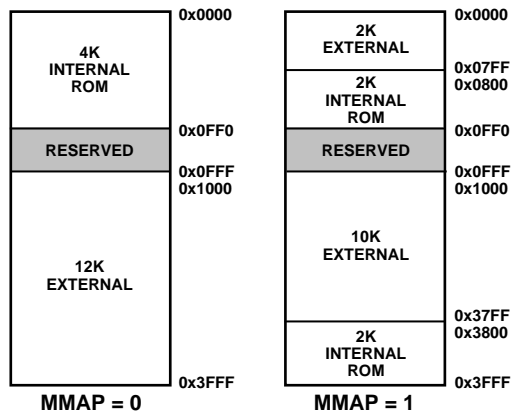

Figure 6. ADSP-2163/ADSP-2164 Program Memory Maps

### Data Memory Interface

The data memory address bus (DMA) is 14 bits wide. The bidirectional external data bus is 24 bits wide, with the upper 16 bits used for data memory data (DMD) transfers.

The data memory select (DMS) signal indicates access to data memory and can be used as a chip select signal. The write (WR) signal indicates a write operation and can be used as a write strobe. The read (RD) signal indicates a read operation and can be used as a read strobe or output enable signal.

The ADSP-216x processors support memory-mapped I/O, with the peripherals memory-mapped into the data memory address space and accessed by the processor in the same manner as data memory.

### Data Memory Map

For the ADSP-2165/ADSP-2166, on-chip data memory RAM resides in the 4K words beginning at address 0x2000, as shown in Figure 7. Data memory locations from 0x3000 to the end of data memory at 0x3FFF are reserved. Control and status registers for the system, timer, wait-state configuration, and serial port operations are located in this region of memory.

The remaining 8K of data memory is located off-chip. This external data memory is divided into three zones, each associated with its own wait-state generator. This allows slower peripherals to be memory-mapped into data memory for which wait states are specified. By mapping peripherals into different zones, you can accommodate peripherals with different wait-state requirements. All zones default to 7 wait states after RESET.

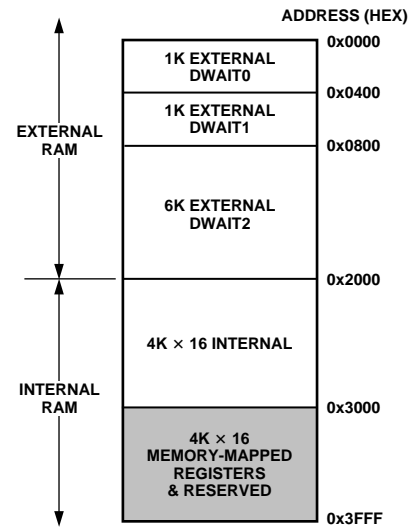

Figure 7. ADSP-2165/ADSP-2166 Data Memory Map

## ADSP-2161/ADSP-2162/ADSP-2163/ADSP-2164

For the ADSP-2161/ADSP-2162/ADSP-2163/ADSP-2164, on-chip data memory RAM resides in the 512 words beginning at address 0x3800, also shown in Figure 8. Data memory locations from 0x3A00 to the end of data memory at 0x3FFF are reserved. Control and status registers for the system, timer, wait-state configuration, and serial port operations are located in this region of memory.

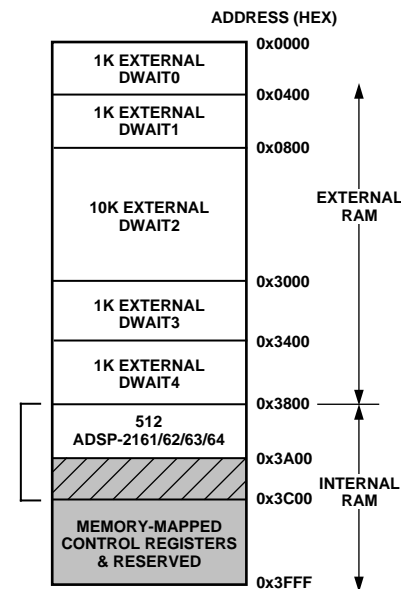

Figure 8. ADSP-2161/ADSP-2162/ADSP-2163/ADSP-2164 Data Memory Map

The remaining 14K of data memory is located off-chip. This external data memory is divided into five zones, each associated with its own wait-state generator. This allows slower peripherals to be memory-mapped into data memory for which wait states are specified. By mapping peripherals into different zones, you can accommodate peripherals with different wait-state requirements. All zones default to seven wait states after RESET.

### Bus Interface

The ADSP-216x processors can relinquish control of their data and address buses to an external device. When the external device requires control of the buses, it asserts the bus request signal ( $\overline{BR}$ ). If the ADSP-216x is not performing an external memory access, it responds to the active  $\overline{BR}$  input in the next cycle by:

- Three-stating the data and address buses and the PMS,  $\overline{DMS}$ ,  $\overline{BMS}$ ,  $\overline{RD}$ ,  $\overline{WR}$  output drivers,
- Asserting the bus grant (BG) signal, and halting program execution.

If the Go mode is set, however, the ADSP-216x will not halt program execution until it encounters an instruction that requires an external memory access.

If the ADSP-216x is performing an external memory access when the external device asserts the  $\overline{BR}$  signal, it will not three-state the memory interfaces or assert the  $\overline{BG}$  signal until the cycle after the access completes (up to eight cycles later depending on the number of wait states). The instruction does not need to be completed when the bus is granted; the ADSP-21xx will grant the bus between two memory accesses if an instruction requires more than one external memory access.

When the  $\overline{BR}$  signal is released, the processor releases the  $\overline{BG}$  signal, re-enables the output drivers and continues program execution from the point at which it stopped.

The bus request feature operates at all times, including when the processor is booting and when  $\overline{RESET}$  is active. If this feature is not used, the  $\overline{BR}$  input should be tied high (to  $V_{DD}$ ).

### POWER-DOWN

The ADSP-2165/ADSP-2166 processors have a low power feature that lets the processor enter a very low power dormant state through hardware or software control. A list of power-down features follows:

- Processor registers and on-chip memory contents are maintained during power-down.
- Power-down mode holds the processor in CMOS standby with a maximum current of less than 100  $\mu A$  in some modes.
- Support for an externally generated TTL or CMOS processor clock. The external clock can continue running during power-down without affecting the lowest power rating.
- Support for crystal operation includes disabling the oscillator to save power. (The processor automatically waits 4096 CLKIN cycles for the crystal oscillator to start and stabilize).
- When power-down mode is enabled, powering down of the processor can be initiated either by externally generated  $\overline{IRQ2}$  interrupt or by using the  $\overline{IRQ2}$  force bit in the IFC register.
- Power-Down Acknowledge Pin (PWDACK) indicates when the processor has entered power-down.
- Interrupt support allows an unlimited number of instructions to be executed before optionally powering down.
- Context clear/save control allows the processor to continue where it left off or start with a clean context when leaving the power-down state.

- Low-to-high transition of the power-down flag input pin (PWDFLAG) can be used to terminate power-down.
- The  $\overline{RESET}$  pin also can also be used to terminate power-down.

### Power-Down Control

Several parameters of power-down operation can be controlled through control bits of the “power-down/sport1 autobuffer control register.” This control register is memory-mapped at location 0x3FEF and the power-down control bits are as follows:

bit[15] xtal: xtal pin disable during power-down  
1 = disabled, 0 = enable (default)

bit[14] pwdflag: (read only)

when  $pwdena = 1$ , the value of bit [14] pwdflag is equal to the status of the pwdflag input pin.

when  $pwdena = 0$ , the value of bit [14] pwdflag is equal to 0.

bit[13]  $pwdena$ : power-down enable

1 = enable, 0 = disable (default)

if  $pwdena$  is set to 0, then the output pin PWDACK is driven low and the input pin PWDFLAG is disabled

Note: It is not recommended that power-down enable be set or cleared during an  $\overline{IRQ2}$  interrupt.

bit[12] pucr: power-up context reset

1 = soft reset, 0 = resume execution (default)

### Entering Power-Down

The power-down sequence is defined as follows:

- Enable power-down logic by setting the  $pwdena$  bit in the power-down/sport1 autobuffer control register.

Note: In order to power-down, the  $PWDENA$  bit must be set before the  $\overline{IRQ2}$  interrupt is initiated.

- Initiate the power-down sequence by generating an  $\overline{IRQ2}$  interrupt either externally or by software use of the IFC register.
- The processor vectors to the  $\overline{IRQ2}$  interrupt vector located at 0x0004.
- Any number of housekeeping instructions, starting at location 0x0004 can be executed prior to the processor entering the power-down mode.
- The processor enters the power-down mode when the processor executes an IDLE instruction while executing the  $\overline{IRQ2}$  interrupt routine.

Notes:

- If an RTI instruction is executed before the processor encounter an IDLE instruction, then the processor returns from the  $\overline{IRQ2}$  interrupt and the power-down sequence is aborted.
- The user can differentiate between a “normal”  $\overline{IRQ2}$  interrupt and a “power-down”  $\overline{IRQ2}$  interrupt by resetting the PWDFLAG pin and checking the status of this pin by testing the PWDFLAG bit in the power-down/SPORT1 autobuffer control register located at DM[0x3FEF].

# ADSP-216x

## Exiting Power-Down

The power-down mode can be exited with the use of the PWDFLAG or RESET pin. Applying a low-to-high transition to the PWDFLAG pin takes the processor out of power-down mode. In this case, a delay of 4096 cycles is automatically induced by the processor. Also, depending on the status of the power-up context reset bit (pu<sub>cr</sub>), the processor either

1) continues to execute instructions following the IDLE instruction that caused the power-down. A RTI instruction is required to pass control back to the main routine (pu<sub>cr</sub> = 0)

or

2) resumes operation from power-down by clearing the PC, STATUS, LOOP and CNTR stack. The IMASK and ASTAT registers are set to 0 and the SSTAT goes to 0x55. The processor then starts executing instructions from the address zero (pu<sub>cr</sub> = 1).

In the case where the power-down mode is exited by asserting the RESET pin, the processor state is reset and instruction are executed from address 0x0000. The RESET pin in this case must be held low long enough for the external crystal (if any) and the on-chip PLL to stabilize and lock.

## Low Power IDLE Instruction

The IDLE instruction places the ADSP-216x processor in low power state in which it waits for an interrupt. When an interrupt occurs, it is serviced and execution continues with instruction following IDLE. Typically this next instruction will be a JUMP back to the IDLE instruction. This implements a low power standby loop.

The IDLE *n* instruction is a special version of IDLE that slows the processor's internal clock signal to further reduce power consumption. The reduced clock frequency, a programmable fraction of the normal clock rate, is specified by a selectable divisor, *n*, given in the IDLE instruction. The syntax of the instruction is:

*IDLE n;*

where *n* = 16, 32, 64 or 128.

The instruction leaves the chip in an idle state, operating at the slower rate. While it is in this state, the processor's other internal clock signals, such as SCLK, CLKOUT, and the timer clock, are reduced by the same ratio. Upon receipt of an enabled interrupt, the processor will stay in the IDLE state for up to a maximum of *n* CLKIN cycles, where *n* is the divisor specified in the instruction, before resuming normal operation.

When the IDLE *n* instruction is used, it slows the processor's internal clock and thus its response time to incoming interrupts—the 1-cycle response time of the standard IDLE state is increased by *n*, the clock divisor. When an enabled interrupt is received, the ADSP-216x will remain in the IDLE state for up to a maximum of *n* CLKIN cycles (where *n* = 16, 32, 64 or 128) before resuming normal operation.

When the IDLE *n* instruction is used in systems that have an externally generated serial clock (SCLK), the serial clock rate may be faster than the processor's reduced internal clock rate. Under these conditions, interrupts must not be generated at a faster rate than can be serviced, due to the additional time the processor takes to come out of the IDLE state (a maximum of *n* CLKIN cycles).

## ADSP-216x Prototyping

You can prototype your ADSP-216x system with either ADSP-2101 or ADSP-2103 RAM-based processors. When code is fully developed and debugged, it can be submitted to Analog Devices for conversion into an ADSP-216x ROM product.

The ADSP-2101 EZ-ICE emulator can be used for development of ADSP-216x systems. For the 3.3 V ADSP-2162/ADSP-2164 and ADSP-2166, a voltage converter interface board provides 3.3 V emulation.

Additional overlay memory is used for emulation of ADSP-2161/ADSP-2162 systems. It should be noted that due to the use of off-chip overlay memory to emulate the ADSP-2161/ADSP-2162, a performance loss may be experienced when both executing instructions and fetching program memory data from the off-chip overlay memory in the same cycle. This can be overcome by locating program memory data in on-chip memory.

## Ordering Procedure for ADSP-216x ROM Processors

To place an order for a custom ROM-coded ADSP-2161, ADSP-2162, ADSP-2163, ADSP-2164, ADSP-2165 or ADSP-2166 processor, you must:

1. Complete the following forms contained in the *ADSP ROM Ordering Package*, available from your Analog Devices sales representative:
  - ADSP-216x ROM Specification Form
  - ROM Release Agreement
  - ROM NRE Agreement & Minimum Quantity Order (MQO)
  - Acceptance Agreement for Preproduction ROM Products
2. Return the forms to Analog Devices along with two copies of the Memory Image File (.EXE file) of your ROM code. The files must be supplied on two 3.5" or 5.25" floppy disks for the IBM PC (DOS 2.01 or higher).
3. Place a purchase order with Analog Devices for nonrecurring engineering changes (NRE) associated with ROM product development.

After this information is received, it is entered into Analog Devices' ROM Manager System which assigns a custom ROM model number to the product. This model number will be branded on all prototype and production units manufactured to these specifications.

To minimize the risk of code being altered during this process, Analog Devices verifies that the .EXE files on both floppy disks are identical, and recalculates the checksums for the .EXE file entered into the ROM Manager System. The checksum data, in the form of a ROM Memory Map, a hard copy of the .EXE file, and a ROM Data Verification form are returned to you for inspection.

A signed ROM Verification Form and a purchase order for production units are required prior to any product being manufactured. Prototype units may be applied toward the minimum order quantity.

Upon completion of prototype manufacture, Analog Devices will ship prototype units and a delivery schedule update for production units. An invoice against your purchase order for the NRE charges is issued at this time.

There is a charge for each ROM mask generated and a minimum order quantity. Consult your sales representative for details. A separate order must be placed for parts of a specific package type, temperature range, and speed grade.

**Instruction Set**

The ADSP-216x assembly language uses an algebraic syntax for ease of coding and readability. The sources and destinations of computations and data movements are written explicitly in each assembly statement, eliminating cryptic assembler mnemonics.

Every instruction assembles into a single 24-bit word and executes in a single cycle. The instructions encompass a wide variety of instruction types along with a high degree of operational

parallelism. There are five basic categories of instructions: data move instructions, computational instructions, multifunction instructions, program flow control instructions and miscellaneous instructions. Multifunction instructions perform one or two data moves and a computation.

The instruction set is summarized below. The *ADSP-2100 Family Users Manual* contains a complete reference to the instruction set.

**ALU Instructions**

[IF cond]	AR AF = xop + yop [+ C] ;	<i>Add/Add with Carry</i>
	= xop - yop [+ C- 1] ;	<i>Subtract X - Y/Subtract X - Y with Borrow</i>
	= yop - xop [+ C- 1] ;	<i>Subtract Y - X/Subtract Y - X with Borrow</i>
	= xop AND yop ;	<i>AND</i>
	= xop OR yop ;	<i>OR</i>
	= xop XOR yop ;	<i>XOR</i>
	= PASS xop ;	<i>Pass, Clear</i>
	= -xop ;	<i>Negate</i>
	= NOT xop ;	<i>NOT</i>
	= ABS xop ;	<i>Absolute Value</i>
	= yop + 1 ;	<i>Increment</i>
	= yop - 1 ;	<i>Decrement</i>
	= DIVS yop, xop ;	<i>Divide</i>
	= DIVQ xop ;	

**MAC Instructions**

[IF cond]	MR MF = xop * yop ;	<i>Multiply</i>
	= MR + xop * yop ;	<i>Multiply/Accumulate</i>
	= MR - xop * yop ;	<i>Multiply/Subtract</i>
	= MR ;	<i>Transfer MR</i>
	= 0 ;	<i>Clear</i>

IF MV SAT MR ;

*Conditional MR Saturation*

**Shifter Instructions**

[IF cond]	SR = [SR OR] ASHIFT xop ;	<i>Arithmetic Shift</i>
[IF cond]	SR = [SR OR] LSHIFT xop ;	<i>Logical Shift</i>
	SR = [SR OR] ASHIFT xop BY <exp>;	<i>Arithmetic Shift Immediate</i>
	SR = [SR OR] LSHIFT xop BY <exp>;	<i>Logical Shift Immediate</i>
[IF cond]	SE = EXP xop ;	<i>Derive Exponent</i>
[IF cond]	SB = EXPADJ xop ;	<i>Block Exponent Adjust</i>
[IF cond]	SR = [SR OR] NORM xop ;	<i>Normalize</i>

**Data Move Instructions**

reg = reg ;	<i>Register-to-Register Move</i>
reg = <data> ;	<i>Load Register Immediate</i>
reg = DM (<addr>) ;	<i>Data Memory Read (Direct Address)</i>
dreg = DM (Ix , My) ;	<i>Data Memory Read (Indirect Address)</i>
dreg = PM (Ix , My) ;	<i>Program Memory Read (Indirect Address)</i>
DM (<addr>) = reg ;	<i>Data Memory Write (Direct Address)</i>
DM (Ix , My) = dreg ;	<i>Data Memory Write (Indirect Address)</i>
PM (Ix , My) = dreg ;	<i>Program Memory Write (Indirect Address)</i>

**Multifunction Instructions**

<ALU> <MAC> <SHIFT> , dreg = dreg ;	<i>Computation with Register-to-Register Move</i>
<ALU> <MAC> <SHIFT> , dreg = DM (Ix , My) ;	<i>Computation with Memory Read</i>
<ALU> <MAC> <SHIFT> , dreg = PM (Ix , My) ;	<i>Computation with Memory Read</i>
DM (Ix , My) = dreg , <ALU> <MAC> <SHIFT> ;	<i>Computation with Memory Write</i>
PM (Ix , My) = dreg , <ALU> <MAC> <SHIFT> ;	<i>Computation with Memory Write</i>
dreg = DM (Ix , My) , dreg = PM (Ix , My) ;	<i>Data &amp; Program Memory Read</i>
<ALU> <MAC> , dreg = DM (Ix , My) , dreg = PM (Ix , My) ;	<i>ALU/MAC with Data &amp; Program Memory Read</i>

# ADSP-216x

## Program Flow Instructions

DO <addr> [UNTIL term] ;	<i>Do Until Loop</i>
[IF cond] JUMP (Ix) ;	<i>Jump</i>
[IF cond] JUMP <addr>;	
[IF cond] CALL (Ix) ;	<i>Call Subroutine</i>
[IF cond] CALL <addr>;	
IF [NOT ] FLAG_IN JUMP <addr>;	<i>Jump/Call on Flag In Pin</i>
IF [NOT ] FLAG_IN CALL <addr>;	
[IF cond] SET RESET TOGGLE FLAG_OUT [, ...] ;	<i>Modify Flag Out Pin</i>
[IF cond] RTS ;	<i>Return from Subroutine</i>
[IF cond] RTI ;	<i>Return from Interrupt Service Routine</i>
IDLE [(n)] ;	<i>Idle</i>

## Miscellaneous Instructions

NOP ;	<i>No Operation</i>
MODIFY (Ix , My);	<i>Modify Address Register</i>
[PUSH STS] [, POP CNTR] [, POP PC] [, POP LOOP] ;	<i>Stack Control</i>
ENA DIS SEC_REG [, ...] ;	<i>Mode Control</i>
BIT_REV	
AV_LATCH	
AR_SAT	
M_MODE	
TIMER	
G_MODE	

## Notation Conventions

Ix	Index registers for indirect addressing
My	Modify registers for indirect addressing
<data>	Immediate data value
<addr>	Immediate address value
<exp>	Exponent (shift value) in shift immediate instructions (8-bit signed number)
<ALU>	Any ALU instruction (except divide)
<MAC>	Any multiply-accumulate instruction
<SHIFT>	Any shift instruction (except shift immediate)
cond	Condition code for conditional instruction
term	Termination code for DO UNTIL loop
dreg	Data register (of ALU, MAC, or Shifter)
reg	Any register (including dregs)
;	A semicolon terminates the instruction
,	Commas separate multiple operations of a single instruction
[ ]	Optional part of instruction
[, ...]	Optional, multiple operations of an instruction
option1   option2	List of options; choose one.

## Assembly Code Example

The following example is a code fragment that performs the filter tap update for an adaptive filter based on a least-mean-squared algorithm. Notice that the computations in the instructions are written like algebraic equations.

```
MF=MX0*MY1(RND), MX0=DM(I2,M1);           {MF=error*beta}
MR=MX0*MF(RND), AY0=PM(I6,M5);
DO adapt UNTIL CE;
  AR=MR1+AY0, MX0=DM(I2,M1), AY0=PM(I6,M7);
adapt:  PM(I6,M6)=AR, MR=MX0*MF(RND);

MODIFY(I2,M3);                             {Point to oldest data}
MODIFY(I6,M7);                             {Point to start of data}
```

# SPECIFICATIONS

## ADSP-2161/ADSP-2163/ADSP-2165—RECOMMENDED OPERATING CONDITIONS

Parameter	K Grade		B Grade		Unit
	Min	Max	Min	Max	
V <sub>DD</sub> Supply Voltage	4.50	5.50	4.50	5.50	V
T <sub>AMB</sub> Ambient Operating Temperature	0	+70	-40	+85	°C

See “Environmental Conditions” for information on thermal specifications.

## ELECTRICAL CHARACTERISTICS

Parameter	Test Conditions	Min	Max	Unit
V <sub>IH</sub> Hi-Level Input Voltage <sup>1, 2</sup>	@ V <sub>DD</sub> = max	2.0		V
V <sub>IH</sub> Hi-Level CLKIN and Reset Voltage	@ V <sub>DD</sub> = max	2.2		V
V <sub>IL</sub> Lo-Level Input Voltage <sup>1, 3</sup>	@ V <sub>DD</sub> = min		0.8	V
V <sub>OH</sub> Hi-Level Output Voltage <sup>1, 4, 5</sup>	@ V <sub>DD</sub> = min, I <sub>OH</sub> = -0.5 mA	2.4		V
	@ V <sub>DD</sub> = min, I <sub>OH</sub> = -100 μA <sup>6</sup>	V <sub>DD</sub> - 0.3		V
V <sub>OL</sub> Lo-Level Output Voltage <sup>1, 4, 5</sup>	@ V <sub>DD</sub> = min, I <sub>OL</sub> = 2 mA		0.4	V
I <sub>IH</sub> Hi-Level Input Current <sup>3</sup>	@ V <sub>DD</sub> = max, V <sub>IN</sub> = V <sub>DD</sub> max		10	μA
I <sub>IL</sub> Lo-Level Input Current <sup>3</sup>	@ V <sub>DD</sub> = max, V <sub>IN</sub> = 0 V		10	μA
I <sub>OZH</sub> Three-State Leakage Current <sup>7</sup>	@ V <sub>DD</sub> = max, V <sub>IN</sub> = V <sub>DD</sub> max <sup>8</sup>		10	μA
I <sub>OZL</sub> Three-State Leakage Current <sup>7</sup>	@ V <sub>DD</sub> = max, V <sub>IN</sub> = 0 V <sup>8</sup>		10	μA
C <sub>I</sub> Input Pin Capacitance <sup>3, 6, 9</sup>	@ V <sub>IN</sub> = 2.5 V, f <sub>IN</sub> = 1.0 MHz, T <sub>AMB</sub> = 25°C		8	pF
C <sub>O</sub> Output Pin Capacitance <sup>6, 7, 9, 10</sup>	@ V <sub>IN</sub> = 2.5 V, f <sub>IN</sub> = 1.0 MHz, T <sub>AMB</sub> = 25°C		8	pF

### NOTES

<sup>1</sup>Bidirectional pins: D0–D23, SCLK1, RFS1, TFS1, SCLK0, RFS0, TFS0.

<sup>2</sup>Input-only pins: RESET, IRQ2, BR, MMAP, DR1, DR0.

<sup>3</sup>Input-only pins: CLKIN, RESET, IRQ2, BR, MMAP, DR1, DR0.

<sup>4</sup>Output pins: BG, PMS, DMS, BMS, RD, WR, A0–A13, CLKOUT, DT1, DT0.

<sup>5</sup>Although specified for TTL outputs, all ADSP-21xx outputs are CMOS-compatible and will drive to V<sub>DD</sub> and GND, assuming no dc loads.

<sup>6</sup>Guaranteed but not tested.

<sup>7</sup>Three-stateable pins: A0–A13, D0–D23, PMS, DMS, BMS, RD, WR, DT1, SCLK1, RFS1, TFS1, DT0, SCLK0, RFS0, TFS0.

<sup>8</sup>0 V on BR, CLKIN Active (to force three-state condition).

<sup>9</sup>Applies to PLCC, MQFP package types.

<sup>10</sup>Output pin capacitance is the capacitive load for any three-stated output pin.

Specifications subject to change without notice.

### ABSOLUTE MAXIMUM RATINGS\*

Supply Voltage . . . . . -0.3 V to +7 V

Input Voltage . . . . . -0.3 V to V<sub>DD</sub> + 0.3 V

Output Voltage Swing . . . . . -0.3 V to V<sub>DD</sub> + 0.3 V

Operating Temperature Range (Ambient) . . . -40°C to +85°C

(No Extended Temperature Range)

Storage Temperature Range . . . . . -65°C to +150°C

Lead Temperature (10 sec) PGA . . . . . +300°C

Lead Temperature (5 sec) PLCC, MQFP, TQFP . . . +280°C

\*Stresses greater than those listed above may cause permanent damage to the device. These are stress ratings only; functional operation of the device at these or any other conditions greater than those indicated in the operational sections of this specification is not implied. Exposure to absolute maximum rating conditions for extended periods may affect device reliability.

### CAUTION

ESD (electrostatic discharge) sensitive device. Electrostatic charges as high as 4000 V readily accumulate on the human body and test equipment and can discharge without detection. Although the ADSP-216x features proprietary ESD protection circuitry, permanent damage may occur on devices subjected to high energy electrostatic discharges. Therefore, proper ESD precautions are recommended to avoid performance degradation or loss of functionality.



# ADSP-216x

## SPECIFICATIONS

### ADSP-2161/ADSP-2163/ADSP-2165—SUPPLY CURRENT AND POWER

Parameter	Test Conditions	Min	Max	Unit
$I_{DD}$ Supply Current (Dynamic) <sup>1</sup>	@ $V_{DD} = \max$ , $t_{CK} = 40 \text{ ns}^2$		38	mA
	@ $V_{DD} = \max$ , $t_{CK} = 50 \text{ ns}^2$		31	mA
	@ $V_{DD} = \max$ , $t_{CK} = 60 \text{ ns}^2$		27	mA
$I_{DD}$ Supply Current (Idle) <sup>1, 3</sup>	@ $V_{DD} = \max$ , $t_{CK} = 40 \text{ ns}$		12	mA
	@ $V_{DD} = \max$ , $t_{CK} = 50 \text{ ns}$		11	mA
	@ $V_{DD} = \max$ , $t_{CK} = 60 \text{ ns}$		10	mA

#### NOTES

<sup>1</sup>Current reflects device operating with no output loads.

<sup>2</sup> $V_{IN} = 0.4 \text{ V}$  and  $2.4 \text{ V}$ .

<sup>3</sup>Idle refers to ADSP-21xx state of operation during execution of IDLE instruction. Deasserted pins are driven to either  $V_{DD}$  or GND.

For typical supply current (internal power dissipation) figures, see Figure 9.

Specifications subject to change without notice.

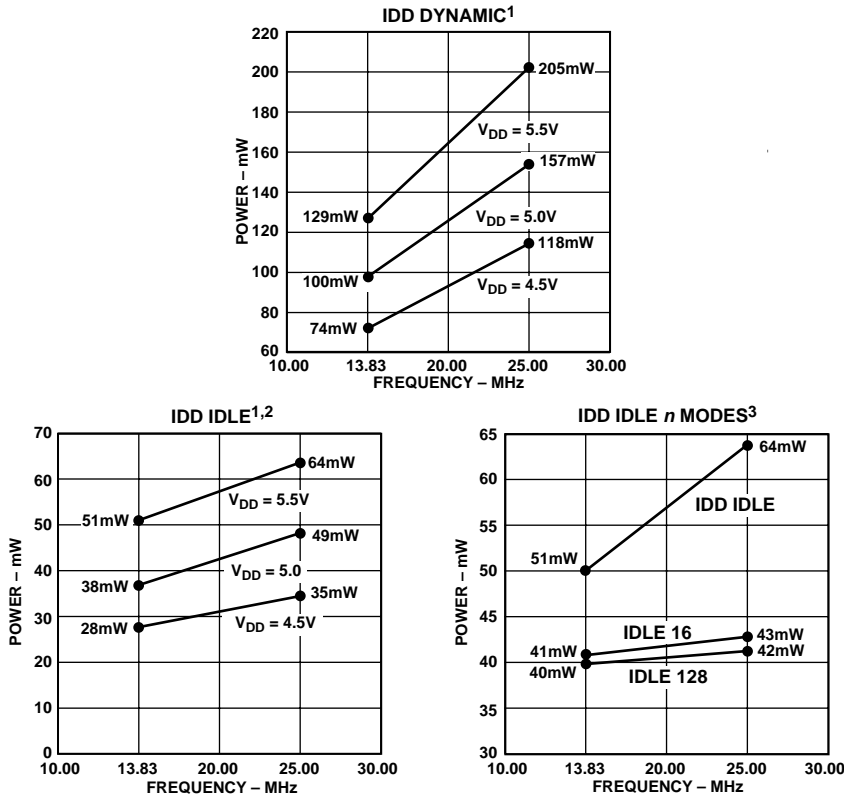

VALID FOR ALL TEMPERATURE GRADES.

<sup>1</sup>POWER REFLECTS DEVICE OPERATING WITH NO OUTPUT LOADS.

<sup>2</sup>IDLE REFERS TO ADSP-216x OPERATION DURING EXECUTION OF IDLE INSTRUCTION. DEASSERTED PINS ARE DRIVEN TO EITHER  $V_{DD}$  OR GND.

<sup>3</sup>MAXIMUM POWER DISSIPATION AT  $V_{DD} = 5.5\text{V}$  DURING EXECUTION OF IDLE n INSTRUCTION.

Figure 9. ADSP-2161/ADSP-2163/ADSP-2165 (Typical) vs. Frequency

## ADSP-2161/ADSP-2163/ADSP-2165

### POWER DISSIPATION EXAMPLE

To determine total power dissipation in a specific application, the following equation should be applied for each output:

$$C \times V_{DD}^2 \times f$$

$C$  = load capacitance,  $f$  = output switching frequency.

#### Example:

In an ADSP-2161 application where external data memory is used and no other outputs are active, power dissipation is calculated as follows:

*Assumptions:*

- External data memory is accessed every cycle with 50% of the address pins switching.
- External data memory writes occur every other cycle with 50% of the data pins switching.
- Each address and data pin has a 10 pF total load at the pin.
- The application operates at  $V_{DD} = 5.0$  V and  $t_{CK} = 50$  ns.

$$\text{Total Power Dissipation} = P_{INT} + (C \times V_{DD}^2 \times f)$$

$P_{INT}$  = internal power dissipation (from Figure 9).

$(C \times V_{DD}^2 \times f)$  is calculated for each output:

Output	# of Pins	$\times C$	$\times V_{DD}^2$	$\times f$
Address, $\overline{DMS}$	8	$\times 10$ pF	$\times 5^2$ V	$\times 20$ MHz = 40.0 mW
Data, $\overline{WR}$	9	$\times 10$ pF	$\times 5^2$ V	$\times 10$ MHz = 22.5 mW
$\overline{RD}$	1	$\times 10$ pF	$\times 5^2$ V	$\times 10$ MHz = 2.5 mW
CLKOUT	1	$\times 10$ pF	$\times 5^2$ V	$\times 20$ MHz = 5.0 mW
				70.0 mW

Total power dissipation for this example =  $P_{INT} + 70.0$  mW.

### ENVIRONMENTAL CONDITIONS

Ambient Temperature Rating:

$$T_{AMB} = T_{CASE} - (PD \times \theta_{CA})$$

$T_{CASE}$  = Case Temperature in °C

$PD$  = Power Dissipation in W

$\theta_{CA}$  = Thermal Resistance (Case-to-Ambient)

$\theta_{JA}$  = Thermal Resistance (Junction-to-Ambient)

$\theta_{JC}$  = Thermal Resistance (Junction-to-Case)

Package	$\theta_{JA}$	$\theta_{JC}$	$\theta_{CA}$
PLCC	27°C/W	16°C/W	11°C/W
MQFP	60°C/W	18°C/W	42°C/W

### CAPACITIVE LOADING

Figures 10 and 11 show capacitive loading characteristics for the ADSP-2161/ADSP-2163/ADSP-2165.

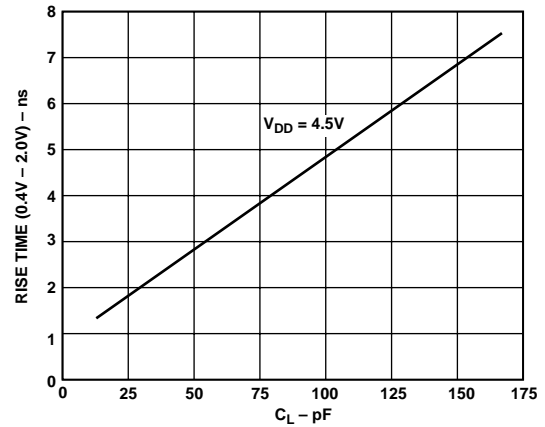

Figure 10. Typical Output Rise Time vs. Load Capacitance,  $C_L$  (at Maximum Ambient Operating Temperature)

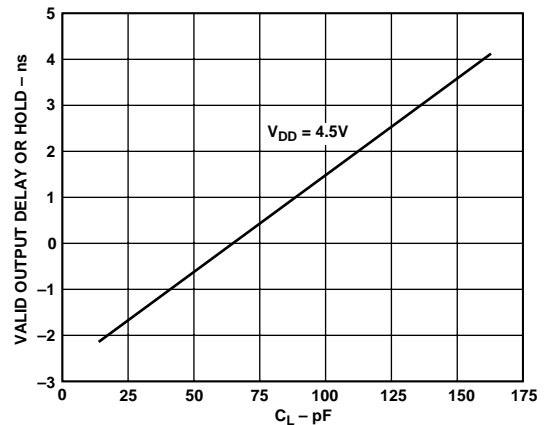

Figure 11. Typical Output Valid Delay or Hold vs. Load Capacitance,  $C_L$  (at Maximum Ambient Operating Temperature)

# SPECIFICATIONS

## ADSP-2161/ADSP-2163/ADSP-2165

### TEST CONDITIONS

Figure 12 shows voltage reference levels for ac measurements.

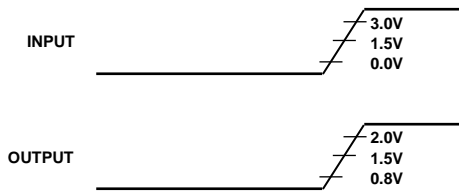

Figure 12. Voltage Reference Levels for AC Measurements (Except Output Enable/Disable)

### Output Disable Time

Output pins are considered to be disabled when they have stopped driving and started a transition from the measured output high or low voltage to a high impedance state. The output disable time ( $t_{DIS}$ ) is the difference of  $t_{MEASURED}$  and  $t_{DECAY}$ , as shown in Figure 13. The time  $t_{MEASURED}$  is the interval from when a reference signal reaches a high or low voltage level to when the output voltages have changed by 0.5 V from the measured output high or low voltage.

The decay time,  $t_{DECAY}$ , is dependent on the capacitive load,  $C_L$ , and the current load,  $i_L$ , on the output pin. It can be approximated by the following equation:

$$t_{DECAY} = \frac{C_L \times 0.5V}{i_L}$$

from which

$$t_{DIS} = t_{MEASURED} - t_{DECAY}$$

is calculated. If multiple pins (such as the data bus) are disabled, the measurement value is that of the last pin to stop driving.

### Output Enable Time

Output pins are considered to be enabled when they have made a transition from a high-impedance state to when they start driving. The output enable time ( $t_{ENA}$ ) is the interval from when a reference signal reaches a high or low voltage level to when the output has reached a specified high or low trip point, as shown in Figure 13. If multiple pins (such as the data bus) are enabled, the measurement value is that of the first pin to start driving.

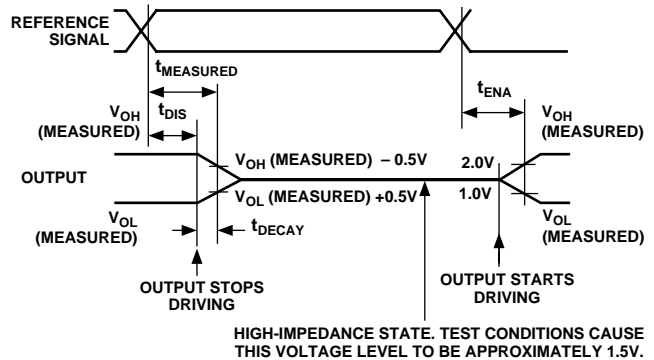

Figure 13. Output Enable/Disable

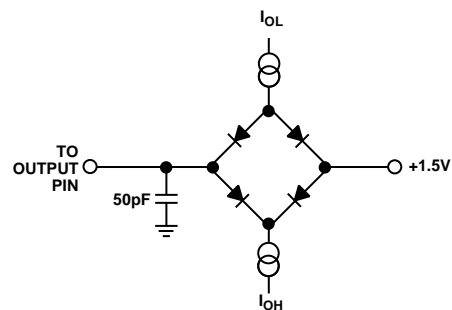

Figure 14. Equivalent Device Loading for AC Measurements (Except Output Enable/Disable)

## ADSP-2162/ADSP-2164/ADSP-2166—RECOMMENDED OPERATING CONDITIONS

Parameter		K Grade		B Grade		Unit
		Min	Max	Min	Max	
V <sub>DD</sub>	Supply Voltage	3.00	3.60	3.00	3.60	V
T <sub>AMB</sub>	Ambient Operating Temperature	0	+70	-40	+85	°C

See “Environmental Conditions” for information on thermal specifications.

## ELECTRICAL CHARACTERISTICS

Parameter	Test Conditions	Min	Max	Unit
V <sub>IH</sub>	Hi-Level Input Voltage <sup>1, 2</sup>	@ V <sub>DD</sub> = max	2.0	V
V <sub>IH</sub>	Hi-Level CLKIN and Reset Voltage	@ V <sub>DD</sub> = max	2.2	V
V <sub>IL</sub>	Lo-Level Input Voltage <sup>1, 3</sup>	@ V <sub>DD</sub> = min		V
V <sub>OH</sub>	Hi-Level Output Voltage <sup>2, 3, 4</sup>	@ V <sub>DD</sub> = min, I <sub>OH</sub> = -0.5 mA <sup>4</sup>	2.4	V
V <sub>OL</sub>	Lo-Level Output Voltage <sup>2, 3, 4</sup>	@ V <sub>DD</sub> = min, I <sub>OL</sub> = 2 mA <sup>4</sup>		V
I <sub>IH</sub>	Hi-Level Input Current <sup>3</sup>	@ V <sub>DD</sub> = max, V <sub>IN</sub> = V <sub>DD</sub> max	10	μA
I <sub>IL</sub>	Lo-Level Input Current <sup>3</sup>	@ V <sub>DD</sub> = max, V <sub>IN</sub> = 0 V	10	μA
I <sub>OZH</sub>	Three-State Leakage Current <sup>5</sup>	@ V <sub>DD</sub> = max, V <sub>IN</sub> = V <sub>DD</sub> max <sup>6</sup>	10	μA
I <sub>OZL</sub>	Three-State Leakage Current <sup>5</sup>	@ V <sub>DD</sub> = max, V <sub>IN</sub> = 0 V <sup>6</sup>	10	μA
C <sub>I</sub>	Input Pin Capacitance <sup>1, 7, 8</sup>	@ V <sub>IN</sub> = 2.5 V, f <sub>IN</sub> = 1.0 MHz, T <sub>AMB</sub> = 25°C	8	pF
C <sub>O</sub>	Output Pin Capacitance <sup>2, 7, 8, 9</sup>	@ V <sub>IN</sub> = 2.5 V, f <sub>IN</sub> = 1.0 MHz, T <sub>AMB</sub> = 25°C	8	pF

## NOTES

<sup>1</sup>Input-only pins: CLKIN, RESET, IRQ2, BR, MMAP, DR1, DR0.

<sup>2</sup>Bidirectional pins: D0–D23, SCLK1, RFS1, TFS1, SCLK0, RFS0, TFS0.

<sup>3</sup>Output pins: BG, PMS, DMS, BMS, RD, WR, A0–A13, CLKOUT, DT1, DT0.

<sup>4</sup>All ADSP-2162, ADSP-2164 and ADSP-2166 outputs are CMOS and will drive to V<sub>DD</sub> and GND with no dc loads.

<sup>5</sup>Three-stateable pins: A0–A13, D0–D23, PMS, DMS, BMS, RD, WR, DT1, SCLK1, RFS1, TFS1, DT0, SCLK0, RFS0, TFS0.

<sup>6</sup>0 V on BR, CLKIN Active (to force three-state condition).

<sup>7</sup>Guaranteed but not tested.

<sup>8</sup>Applies to PLCC and MQFP package types.

<sup>9</sup>Output pin capacitance is the capacitive load for any three-stated output pin.

Specifications subject to change without notice.

## ABSOLUTE MAXIMUM RATINGS\*

Supply Voltage . . . . . -0.3 V to +4.5 V  
 Input Voltage . . . . . -0.3 V to V<sub>DD</sub> + 0.3 V  
 Output Voltage Swing . . . . . -0.3 V to V<sub>DD</sub> + 0.3 V  
 Operating Temperature Range (Ambient) . . . -40°C to +85°C  
 Storage Temperature Range . . . . . -65°C to +150°C  
 Lead Temperature (5 sec) PLCC, MQFP . . . . . +280°C

\*Stresses greater than those listed above may cause permanent damage to the device. These are stress ratings only, and functional operation of the device at these or any other conditions greater than those indicated in the operational sections of this specification is not implied. Exposure to absolute maximum rating conditions for extended periods may affect device reliability.

# ADSP-216x

## SPECIFICATIONS

### ADSP-2162/ADSP-2164/ADSP-2166—SUPPLY CURRENT AND POWER

Parameter	Test Conditions	Min	Max	Unit
$I_{DD}$ Supply Current (Dynamic) <sup>1</sup>	@ $V_{DD} = \text{max}$ , $t_{CK} = 60 \text{ ns}^2$		16	mA
	@ $V_{DD} = \text{max}$ , $t_{CK} = 76.9 \text{ ns}$		15	mA
	@ $V_{DD} = \text{max}$ , $t_{CK} = 97.6 \text{ ns}$		14	mA
$I_{DD}$ Supply Current (Idle) <sup>1, 3</sup>	@ $V_{DD} = \text{max}$ , $t_{CK} = 60 \text{ ns}$		5	mA
	@ $V_{DD} = \text{max}$ , $t_{CK} = 76.9 \text{ ns}$		4	mA
	@ $V_{DD} = \text{max}$ , $t_{CK} = 97.6 \text{ ns}$		4	mA

#### NOTES

<sup>1</sup>Current reflects device operating with no output loads.

<sup>2</sup> $V_{IN} = 0.4 \text{ V}$  and  $2.4 \text{ V}$ .

<sup>3</sup>Idle refers to ADSP-216x state of operation during execution of IDLE instruction. Deasserted pins are driven to either  $V_{DD}$  or GND. For typical supply current (internal power dissipation) figures, see Figure 15.

Specifications subject to change without notice.

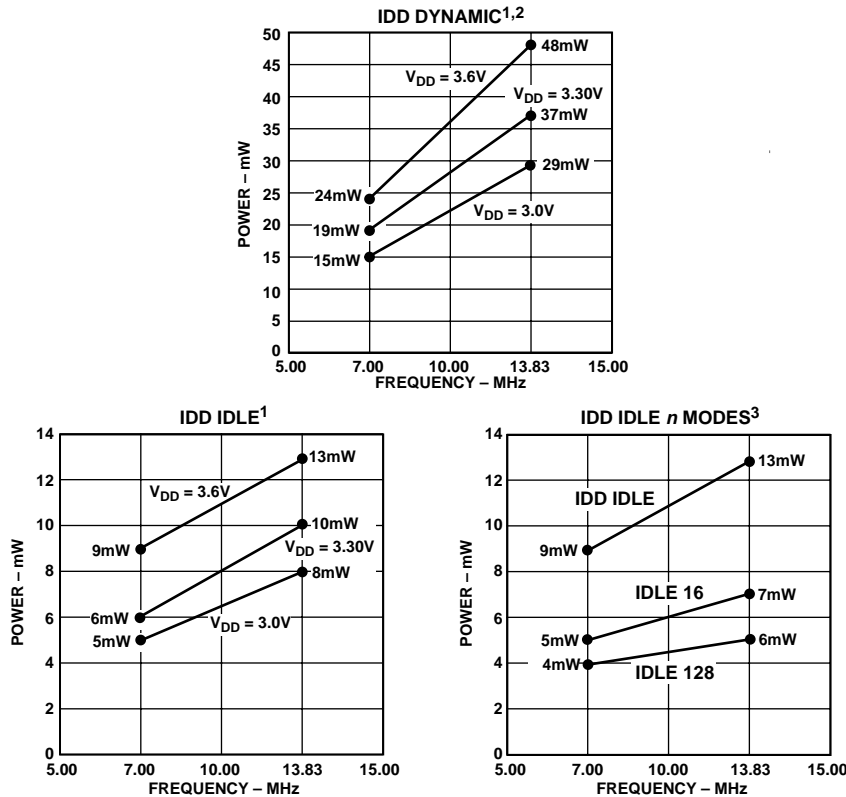

VALID FOR ALL TEMPERATURE GRADES.

<sup>1</sup>POWER REFLECTS DEVICE OPERATING WITH NO OUTPUT LOADS.

<sup>2</sup>IDLE REFERS TO ADSP-216x OPERATION DURING EXECUTION OF IDLE INSTRUCTION. DEASSERTED PINS ARE DRIVEN TO EITHER  $V_{DD}$  OR GND.

<sup>3</sup>MAXIMUM POWER DISSIPATION AT  $V_{DD} = 3.6\text{V}$  DURING EXECUTION OF IDLE *n* INSTRUCTION.

Figure 15. ADSP-2162 Power (Typical) vs. Frequency)

## ADSP-2162/ADSP-2164/ADSP-2166

### POWER DISSIPATION EXAMPLE

To determine total power dissipation in a specific application, the following equation should be applied for each output:

$$C \times V_{DD}^2 \times f$$

$C$  = load capacitance,  $f$  = output switching frequency.

#### Example:

In an ADSP-2162 application where external data memory is used and no other outputs are active, power dissipation is calculated as follows:

#### Assumptions:

- External data memory is accessed every cycle with 50% of the address pins switching.
- External data memory writes occur every other cycle with 50% of the data pins switching.
- Each address and data pin has a 10 pF total load at the pin.
- The application operates at  $V_{DD} = 3.3$  V and  $t_{CK} = 100$  ns.

$$\text{Total Power Dissipation} = P_{INT} + (C \times V_{DD}^2 \times f)$$

$P_{INT}$  = internal power dissipation (from Figure 15).

$(C \times V_{DD}^2 \times f)$  is calculated for each output:

Output	# of Pins	$\times C$	$\times V_{DD}^2$	$\times f$	
Address, $\overline{DMS}$	8	$\times 10$ pF	$\times 3.3^2$ V	$\times 10$ MHz	= 8.71 mW
Data, $\overline{WR}$	9	$\times 10$ pF	$\times 3.3^2$ V	$\times 5$ MHz	= 4.90 mW
$\overline{RD}$	1	$\times 10$ pF	$\times 3.3^2$ V	$\times 5$ MHz	= 0.55 mW
CLKOUT	1	$\times 10$ pF	$\times 3.3^2$ V	$\times 10$ MHz	= 1.09 mW
					15.25 mW

Total power dissipation for this example =  $P_{INT} + 15.25$  mW.

### ENVIRONMENTAL CONDITIONS

Ambient Temperature Rating:

$$T_{AMB} = T_{CASE} - (PD \times \theta_{CA})$$

$T_{CASE}$  = Case Temperature in °C

PD = Power Dissipation in W

$\theta_{CA}$  = Thermal Resistance (Case-to-Ambient)

$\theta_{JA}$  = Thermal Resistance (Junction-to-Ambient)

$\theta_{JC}$  = Thermal Resistance (Junction-to-Case)

Package	$\theta_{JA}$	$\theta_{JC}$	$\theta_{CA}$
MQFP	60°C/W	18°C/W	42°C/W

### CAPACITIVE LOADING

Figures 16 and 17 show capacitive loading characteristics for the ADSP-2162 and ADSP-2164.

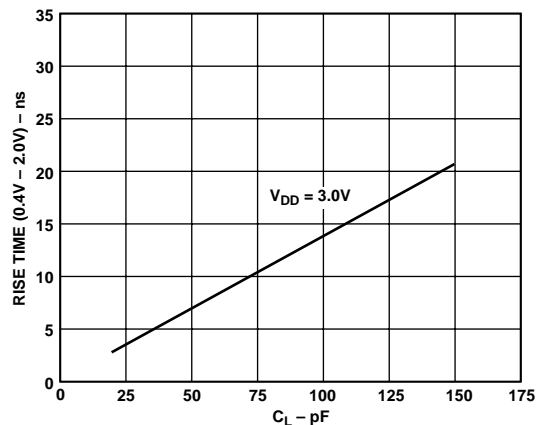

Figure 16. Typical Output Rise Time vs. Load Capacitance,  $C_L$  (at Maximum Ambient Operating Temperature)

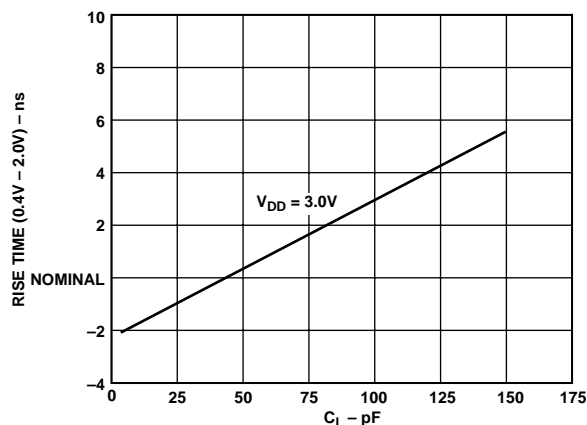

Figure 17. Typical Output Valid Delay or Hold vs. Load Capacitance,  $C_L$  (at Maximum Ambient Operating Temperature)

# ADSP-216x

## SPECIFICATIONS

### ADSP-2162/ADSP-2164/ADSP-2166

#### TEST CONDITIONS

Figure 18 shows voltage reference levels for ac measurements.

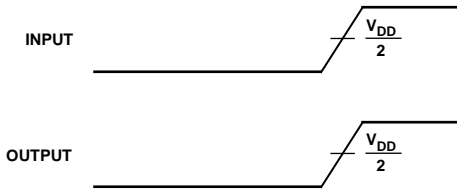

Figure 18. Voltage Reference Levels for AC Measurements (Except Output Enable/Disable)

#### Output Disable Time

Output pins are considered to be disabled when they have stopped driving and started a transition from the measured output high or low voltage to a high impedance state. The output disable time ( $t_{DIS}$ ) is the difference of  $t_{MEASURED}$  and  $t_{DECAY}$ , as shown in Figure 19. The time  $t_{MEASURED}$  is the interval from when a reference signal reaches a high or low voltage level to when the output voltages have changed by 0.5 V from the measured output high or low voltage.

The decay time,  $t_{DECAY}$ , is dependent on the capacitive load,  $C_L$ , and the current load,  $i_L$ , on the output pin. It can be approximated by the following equation:

$$t_{DECAY} = \frac{C_L \times 0.5V}{i_L}$$

from which

$$t_{DIS} = t_{MEASURED} - t_{DECAY}$$

is calculated. If multiple pins (such as the data bus) are disabled, the measurement value is that of the last pin to stop driving.

#### Output Enable Time

Output pins are considered to be enabled when they have made a transition from a high-impedance state to when they start driving. The output enable time ( $t_{ENA}$ ) is the interval from when a reference signal reaches a high or low voltage level to when the output has reached a specified high or low trip point, as shown in Figure 19. If multiple pins (such as the data bus) are enabled, the measurement value is that of the first pin to start driving.

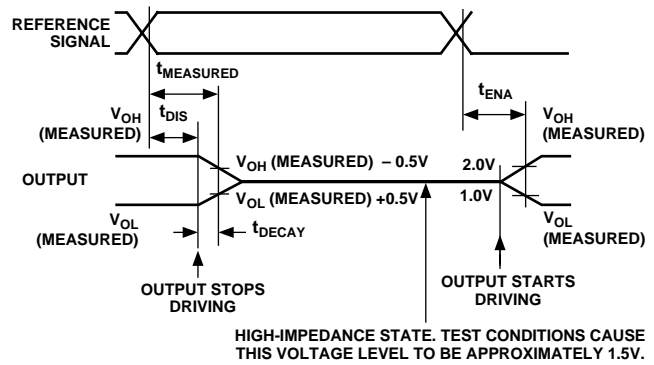

Figure 19. Output Enable/Disable

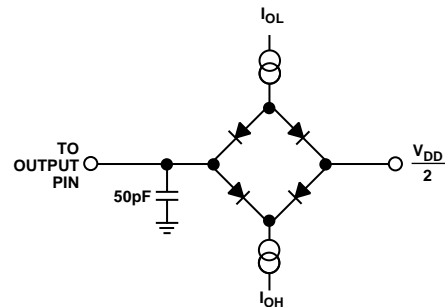

Figure 20. Equivalent Device Loading for AC Measurements (Except Output Enable/Disable)

**TIMING PARAMETERS (ADSP-2161/ADSP-2163/ADSP-2165)**

**GENERAL NOTES**

Use the exact timing information given. Do not attempt to derive parameters from the addition or subtraction of others. While addition or subtraction would yield meaningful results for an individual device, the values given in this data sheet reflect statistical variations and worst cases. Consequently, you cannot meaningfully add parameters to derive longer times.

**TIMING NOTES**

*Switching Characteristics* specify how the processor changes its signals. You have no control over this timing—circuitry external to the processor must be designed for compatibility with these signal characteristics. Switching characteristics tell you what the processor will do in a given circumstance. You can also use

switching characteristics to ensure that any timing requirement of a device connected to the processor (such as memory) is satisfied.

*Timing Requirements* apply to signals that are controlled by circuitry external to the processor, such as the data input for a read operation. Timing requirements guarantee that the processor operates correctly with other devices.

**MEMORY REQUIREMENTS**

The table below shows common memory device specifications and the corresponding ADSP-216x timing parameters, for your convenience.

Memory Device Specification	ADSP-216x Timing Parameter	Timing Parameter Definition
Address Setup to Write Start	$t_{ASW}$	A0–A13, $\overline{DMS}$ , $\overline{PMS}$ Setup Before $\overline{WR}$ Low
Address Setup to Write End	$t_{AW}$	A0–A13, $\overline{DMS}$ , $\overline{PMS}$ Setup Before $\overline{WR}$ Deasserted
Address Hold Time	$t_{WRA}$	A0–A13, $\overline{DMS}$ , $\overline{PMS}$ Hold After $\overline{WR}$ Deasserted
Data Setup Time	$t_{DW}$	Data Setup Before $\overline{WR}$ High
Data Hold Time	$t_{DH}$	Data Hold After $\overline{WR}$ High
$\overline{OE}$ to Data Valid	$t_{RDD}$	$\overline{RD}$ Low to Data Valid
Address Access Time	$t_{AA}$	A0–A13, $\overline{DMS}$ , $\overline{PMS}$ , $\overline{BMS}$ to Data Valid

# ADSP-216x

## TIMING PARAMETERS (ADSP-2161/ADSP-2163/ADSP-2165)

### CLOCK SIGNALS AND RESET

Parameter	16.67 MHz		20 MHz		25 MHz		Frequency Dependency		Unit
	Min	Max	Min	Max	Min	Max	Min	Max	
<i>Timing Requirements:</i>									
$t_{CK}$ CLKIN Period	60	150	50	150	40	150	$t_{CK}$	150	ns
$t_{CKL}$ CLKIN Width Low	20		20		15		20		ns
$t_{CKH}$ CLKIN Width High	20		20		15		20		ns
$t_{RSP}$ RESET Width Low	300		250		200		$5t_{CK}^1$		ns
<i>Switching Characteristics:</i>									
$t_{CPL}$ CLKOUT Width Low	20		15		10		$0.5t_{CK} - 10$		ns
$t_{CPH}$ CLKOUT Width High	20		15		10		$0.5t_{CK} - 10$		ns
$t_{CKOH}$ CLKIN High to CLKOUT High	0	20	0	20	0	$15^2$	0	$20^2$	ns

#### NOTES

<sup>1</sup>Applies after power-up sequence is complete. Internal phase lock loop requires no more than 2000 CLKIN cycles, assuming stable CLKIN (not including crystal oscillator startup time).

<sup>2</sup>For 25 MHz only, the maximum frequency dependency for  $t_{CKOH} = 15$  ns.

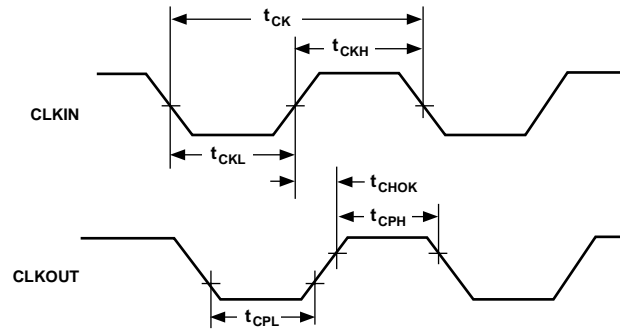

Figure 21. Clock Signals

**TIMING PARAMETERS (ADSP-2161/ADSP-2163/ADSP-2165)**

**INTERRUPTS AND FLAGS**

Parameter	16.67 MHz		20 MHz		25 MHz		Frequency Dependency		Unit	
	Min	Max	Min	Max	Min	Max	Min	Max		
<i>Timing Requirements:</i>										
$t_{IFS}$ $\overline{IRQx}^1$ or FI Setup Before CLKOUT Low <sup>2,3</sup>	30		27.5		25		$0.25t_{CK} + 15$		ns	
$t_{IFS}$ $\overline{IRQx}^1$ or FI Setup Before CLKOUT Low <sup>2,3</sup>	33		30.5		28		$0.25t_{CK} + 18$		ns	
$t_{IFH}$ $\overline{IRQx}^1$ or FI Hold After CLKOUT High <sup>2,3</sup>	15		12.5		10		$0.25t_{CK}$		ns	
<i>Switching Characteristics:</i>										
$t_{FOH}$ FO Hold After CLKOUT High	0		0		0		0		ns	
$t_{FOD}$ FO Delay from CLKOUT High		15		15		12 <sup>4</sup>		15 <sup>4</sup>	ns	

NOTES

<sup>1</sup> $\overline{IRQx} = \overline{IRQ0}, \overline{IRQ1},$  and  $\overline{IRQ2}$ .

<sup>2</sup>If  $\overline{IRQx}$  and FI inputs meet  $t_{IFS}$  and  $t_{IFH}$  setup/hold requirements, they will be recognized during the current clock cycle; otherwise they will be recognized during the following cycle. (Refer to the “Interrupt Controller” section in Chapter 3, Program Control, of the *ADSP-2100 Family User’s Manual*, Third Edition for further information on interrupt servicing.)

<sup>3</sup>Edge-sensitive interrupts require pulsewidths greater than 10 ns. Level-sensitive interrupts must be held low until serviced.

<sup>4</sup>For 25 MHz only, the maximum frequency dependency for  $t_{FOD} = 12$  ns.

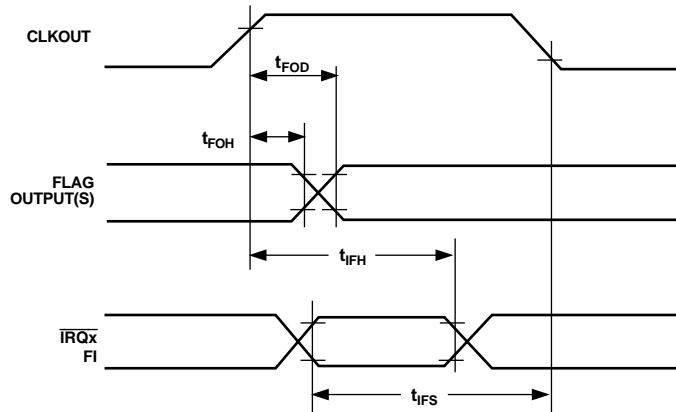

Figure 22. Interrupts and Flags

# ADSP-216x

## TIMING PARAMETERS (ADSP-2161/ADSP-2163/ADSP-2165)

### BUS REQUEST/BUS GRANT

Parameter	16.67 MHz		20 MHz		25 MHz		Frequency Dependency		Unit
	Min	Max	Min	Max	Min	Max	Min	Max	
<i>Timing Requirements:</i>									
$t_{BH}$	$\overline{BR}$ Hold After CLKOUT High <sup>1</sup>		20	17.5	15		$0.25t_{CK} + 5$		ns
$t_{BS}$	$\overline{BR}$ Setup Before CLKOUT Low <sup>1</sup>		35	32.5	30		$0.25t_{CK} + 20$		ns
<i>Switching Characteristics:</i>									
$t_{SD}$	CLKOUT High to $\overline{DMS}$ , $\overline{PMS}$ , $\overline{BMS}$ , $\overline{RD}$ , $\overline{WR}$ Disable		35	32.5	30		$0.25t_{CK} + 20$		ns
$t_{SDB}$	$\overline{DMS}$ , $\overline{PMS}$ , $\overline{BMS}$ , $\overline{RD}$ , $\overline{WR}$ Disable to $\overline{BG}$ Low		0	0	0		0		ns
$t_{SE}$	$\overline{BG}$ High to $\overline{DMS}$ , $\overline{PMS}$ , $\overline{BMS}$ , $\overline{RD}$ , $\overline{WR}$ Enable		0	0	0		0		ns
$t_{SEC}$	$\overline{DMS}$ , $\overline{PMS}$ , $\overline{BMS}$ , $\overline{RD}$ , $\overline{WR}$ Enable to CLKOUT High		5	2.5	$1.5^2$		$0.25t_{CK} - 10^2$		ns

#### NOTES

<sup>1</sup>If  $\overline{BR}$  meets the  $t_{BS}$  and  $t_{BH}$  setup/hold requirements, it will be recognized in the current processor cycle; otherwise it is recognized in the following cycle.  $\overline{BR}$  requires a pulsewidth greater than 10 ns.

<sup>2</sup>For 25 MHz only, the minimum frequency dependency formula for  $t_{SEC} = (0.25t_{CK} - 8.5)$ .

Section 10.2.4, “Bus Request/Grant,” on page 212 of the *ADSP-2100 Family User’s Manual*, Third Edition, states that “When  $\overline{BR}$  is recognized, the processor responds immediately by asserting  $\overline{BG}$  during the same cycle.” This is incorrect for the current versions of all ADSP-21xx processors:  $\overline{BG}$  is asserted in the cycle *after*  $\overline{BR}$  is recognized. No external synchronization circuit is needed when  $\overline{BR}$  is generated as an asynchronous signal.

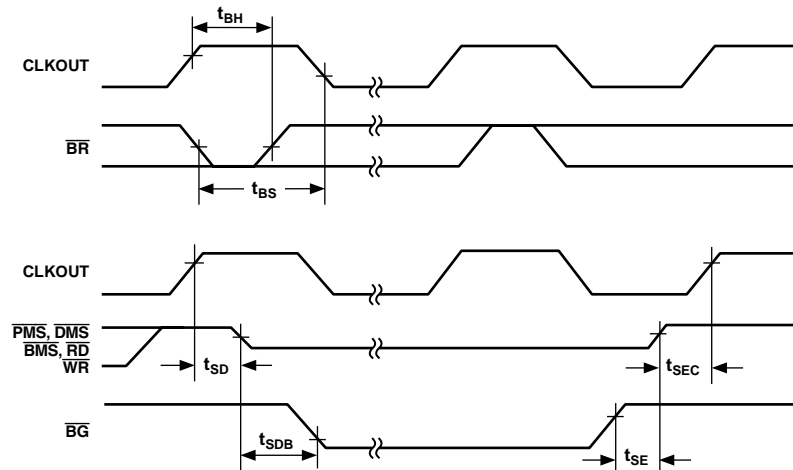

Figure 23. Bus Request/Bus Grant

**TIMING PARAMETERS (ADSP-2161/ADSP-2163/ADSP-2165)**

**MEMORY READ**

Parameter	16.67 MHz		20 MHz		25 MHz		Unit
	Min	Max	Min	Max	Min	Max	
<i>Timing Requirements:</i>							
t <sub>RDD</sub>	RD Low to Data Valid		17		12		ns
t <sub>AA</sub>	A0–A13, PMS, DMS, BMS to Data Valid		27		19.5		ns
t <sub>RDH</sub>	Data Hold from RD High		0		0		ns
<i>Switching Characteristics:</i>							
t <sub>RP</sub>	RD Pulsewidth		22		12		ns
t <sub>CRD</sub>	CLKOUT High to RD Low		10 25		7.5 22.5		ns
t <sub>ASR</sub>	A0–A13, PMS, DMS, BMS Setup Before RD Low		5		2.5		ns
t <sub>RDA</sub>	A0–A13, PMS, DMS, BMS Hold After RD Deasserted		6		3.5		ns
t <sub>RWR</sub>	RD High to RD or WR Low		25		20		ns

Parameter	Frequency Dependency (CLKIN ≤ 25 MHz)		Unit
	Min	Max	
<i>Timing Requirements:</i>			
t <sub>RDD</sub>	RD Low to Data Valid		0.5t <sub>CK</sub> – 13 + w
t <sub>AA</sub>	A0–A13, PMS, DMS, BMS to Data Valid		0.75t <sub>CK</sub> – 18 + w
t <sub>RDH</sub>	Data Hold from RD High		0
<i>Switching Characteristics:</i>			
t <sub>RP</sub>	RD Pulsewidth		0.5t <sub>CK</sub> – 8 + w
t <sub>CRD</sub>	CLKOUT High to RD Low		0.25t <sub>CK</sub> – 5
t <sub>ASR</sub>	A0–A13, PMS, DMS, BMS Setup Before RD Low		0.25t <sub>CK</sub> – 10 <sup>1</sup>
t <sub>RDA</sub>	A0–A13, PMS, DMS, BMS Hold After RD Deasserted		0.25t <sub>CK</sub> – 9
t <sub>RWR</sub>	RD High to RD or WR Low		0.5t <sub>CK</sub> – 5

NOTES

<sup>1</sup>For 25 MHz only, minimum frequency dependency formula for t<sub>ASR</sub> = (0.25t<sub>CK</sub> – 8.5).

w = wait states × t<sub>CK</sub>.

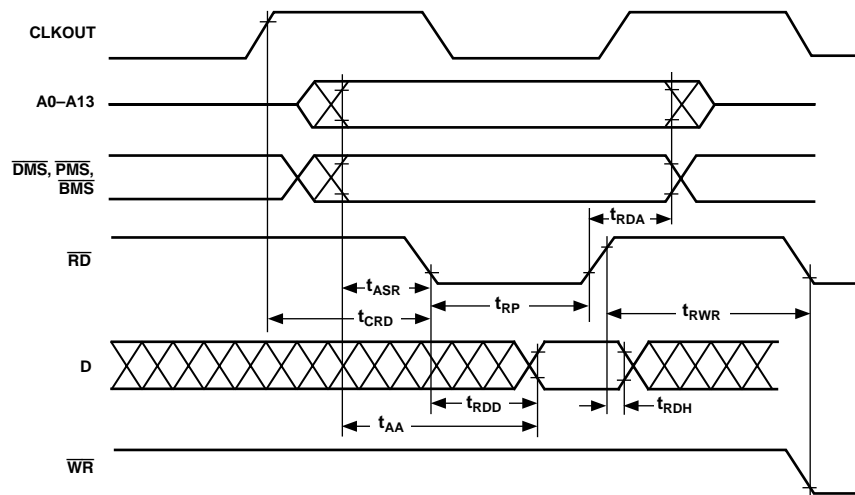

Figure 24. Memory Read

# ADSP-216x

## TIMING PARAMETERS (ADSP-2161/ADSP-2163/ADSP-2165)

### MEMORY WRITE

Parameter	16.67 MHz		20 MHz		25 MHz		Unit
	Min	Max	Min	Max	Min	Max	
<i>Switching Characteristics:</i>							
$t_{DW}$	Data Setup Before $\overline{WR}$ High		17	12	7		ns
$t_{DH}$	Data Hold After $\overline{WR}$ High		5	2.5	0		ns
$t_{WP}$	$\overline{WR}$ Pulsewidth		22	17	12		ns
$t_{WDE}$	$\overline{WR}$ Low to Data Enabled		0	0	0		ns
$t_{ASW}$	A0–A13, $\overline{DMS}$ , $\overline{PMS}$ Setup Before $\overline{WR}$ Low		5	2.5	1.5 <sup>1</sup>		ns
$t_{DDR}$	Data Disable Before $\overline{WR}$ or $\overline{RD}$ Low		5	2.5	1.5 <sup>1</sup>		ns
$t_{CWR}$	CLKOUT High to $\overline{WR}$ Low		10	25	7.5	22.5	ns
$t_{AW}$	A0–A13, $\overline{DMS}$ , $\overline{PMS}$ , Setup Before $\overline{WR}$ Deasserted		23	15.5	8		ns
$t_{WRA}$	A0–A13, $\overline{DMS}$ , $\overline{PMS}$ Hold After $\overline{WR}$ Deasserted		6	3.5	1		ns
$t_{WWR}$	$\overline{WR}$ High to $\overline{RD}$ or $\overline{WR}$ Low		25	20	15		ns

Parameter	Frequency Dependency (CLKIN ≤ 25 MHz)		Unit
	Min	Max	
<i>Switching Characteristics:</i>			
$t_{DW}$	Data Setup Before $\overline{WR}$ High		ns
$t_{DH}$	Data Hold After $\overline{WR}$ High		ns
$t_{WP}$	$\overline{WR}$ Pulsewidth		ns
$t_{WDE}$	$\overline{WR}$ Low to Data Enabled		0
$t_{ASW}$	A0–A13, $\overline{DMS}$ , $\overline{PMS}$ Setup Before $\overline{WR}$ Low		ns
$t_{DDR}$	Data Disable Before $\overline{WR}$ or $\overline{RD}$ Low		ns
$t_{CWR}$	CLKOUT High to $\overline{WR}$ Low		ns
$t_{AW}$	A0–A13, $\overline{DMS}$ , $\overline{PMS}$ , Setup Before $\overline{WR}$ Deasserted		ns
$t_{WRA}$	A0–A13, $\overline{DMS}$ , $\overline{PMS}$ Hold After $\overline{WR}$ Deasserted		ns
$t_{WWR}$	$\overline{WR}$ High to $\overline{RD}$ or $\overline{WR}$ Low		ns

#### NOTES

<sup>1</sup>For 25 MHz only, the minimum frequency dependency formula for  $t_{ASW}$  and  $t_{DDR} = (0.25t_{CK} - 8.5)$ .

w = wait states  $\times t_{CK}$ .

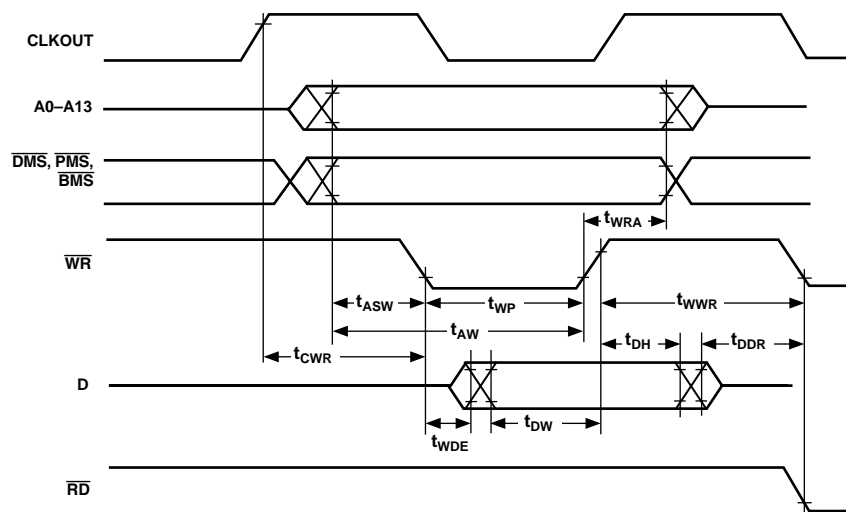

Figure 25. Memory Write

**TIMING PARAMETERS (ADSP-2161/ADSP-2163/ADSP-2165)**

**SERIAL PORTS**

Parameter	13.824 MHz*		Frequency Dependency		Unit		
	Min	Max	Min	Max			
<i>Timing Requirements:</i>							
t <sub>SCK</sub>	SCLK Period		72.3		ns		
t <sub>SCS</sub>	DR/TFS/RFS Setup Before SCLK Low		8		ns		
t <sub>SCH</sub>	DR/TFS/RFS Hold After SCLK Low		10		ns		
t <sub>SCP</sub>	SCLK <sub>IN</sub> Width		28		ns		
<i>Switching Characteristics:</i>							
t <sub>CC</sub>	CLKOUT High to SCLK <sub>OUT</sub>		18.1	33.1	0.25t <sub>CK</sub>	0.25t <sub>CK</sub> + 15	ns
t <sub>SCDE</sub>	SCLK High to DT Enable		0		0		ns
t <sub>SCDV</sub>	SCLK High to DT Valid		0		0	20	ns
t <sub>RH</sub>	TFS/RFS <sub>OUT</sub> Hold After SCLK High		0		0		ns
t <sub>RD</sub>	TFS/RFS <sub>OUT</sub> Delay from SCLK High		0		0	20	ns
t <sub>SCDH</sub>	DT Hold After SCLK High		0		0		ns
t <sub>TDE</sub>	TFS (Alt) to DT Enable		0		0		ns
t <sub>TDV</sub>	TFS (Alt) to DT Valid		0		0	18	ns
t <sub>SCDD</sub>	SCLK High to DT Disable		0		0	25	ns
t <sub>RDV</sub>	RFS (Multichannel, Frame Delay Zero) to DT Valid		0		0	20	ns

\*Maximum serial port operating frequency is 13.824 MHz for all processor speed grades.

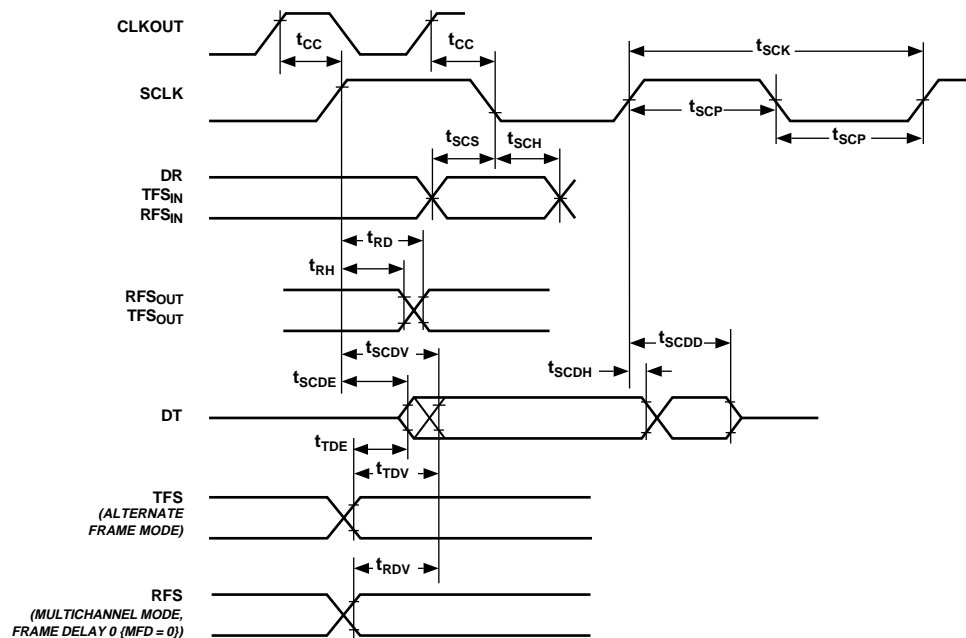

Figure 26. Serial Ports

# ADSP-216x

## TIMING PARAMETERS (ADSP-2162/ADSP-2164/ADSP-2166)

### GENERAL NOTES

Use the exact timing information given. Do not attempt to derive parameters from the addition or subtraction of others. While addition or subtraction would yield meaningful results for an individual device, the values given in this data sheet reflect statistical variations and worst cases. Consequently, you cannot meaningfully add parameters to derive longer times.

### TIMING NOTES

*Switching Characteristics* specify how the processor changes its signals. You have no control over this timing—circuitry external to the processor must be designed for compatibility with these signal characteristics. Switching characteristics tell you what the processor will do in a given circumstance. You can also use

switching characteristics to ensure that any timing requirement of a device connected to the processor (such as memory) is satisfied.

*Timing Requirements* apply to signals that are controlled by circuitry external to the processor, such as the data input for a read operation. Timing requirements guarantee that the processor operates correctly with other devices.

### MEMORY REQUIREMENTS

The table below shows common memory device specifications and the corresponding ADSP-216x timing parameters, for your convenience.

Memory Device Specification	ADSP-216x Timing Parameter	Timing Parameter Definition
Address Setup to Write Start	$t_{ASW}$	A0–A13, $\overline{DMS}$ , $\overline{PMS}$ Setup Before $\overline{WR}$ Low
Address Setup to Write End	$t_{AW}$	A0–A13, $\overline{DMS}$ , $\overline{PMS}$ Setup Before $\overline{WR}$ Deasserted
Address Hold Time	$t_{WRA}$	A0–A13, $\overline{DMS}$ , $\overline{PMS}$ Hold After $\overline{WR}$ Deasserted
Data Setup Time	$t_{DW}$	Data Setup Before $\overline{WR}$ High
Data Hold Time	$t_{DH}$	Data Hold After $\overline{WR}$ High
$\overline{OE}$ to Data Valid	$t_{RDD}$	$\overline{RD}$ Low to Data Valid
Address Access Time	$t_{AA}$	A0–A13, $\overline{DMS}$ , $\overline{PMS}$ , $\overline{BMS}$ to Data Valid

**TIMING PARAMETERS (ADSP-2162/ADSP-2164/ADSP-2166)**

**CLOCK SIGNALS AND RESET**

Parameter	10.24 MHz		13.0 MHz		16.67 MHz		Frequency Dependency		Unit
	Min	Max	Min	Max	Min	Max	Min	Max	
<i>Timing Requirements:</i>									
$t_{CK}$ CLKIN Period	97.6	150	76.9	150	60.0	150	$t_{CK}$	150	ns
$t_{CKL}$ CLKIN Width Low	20		20		20		20		ns
$t_{CKH}$ CLKIN Width High	20		20		20		20		ns
$t_{RSP}$ RESET Width Low	488		384.5		300		$5t_{CK}^1$		ns
<i>Switching Characteristics:</i>									
$t_{CPL}$ CLKOUT Width Low	38.8		28.5		20		$0.5t_{CK} - 10$		ns
$t_{CPH}$ CLKOUT Width High	38.8		28.5		20		$0.5t_{CK} - 10$		ns
$t_{CKOH}$ CLKIN High to CLKOUT High	0	20	0	20	0	20	0	20	ns

NOTE

<sup>1</sup>Applies after power-up sequence is complete. Internal phase lock loop requires no more than 2000 CLKIN cycles assuming stable CLKIN (not including crystal oscillator startup time).

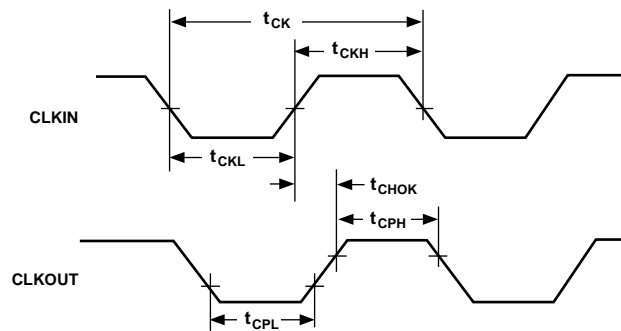

Figure 27. Clock Signals

# ADSP-216x

## TIMING PARAMETERS (ADSP-2162/ADSP-2164/ADSP-2166)

### INTERRUPTS AND FLAGS

Parameter	10.24 MHz		13.0 MHz		16.67 MHz		Frequency Dependency		Unit
	Min	Max	Min	Max	Min	Max	Min	Max	
<i>Timing Requirements:</i>									
$t_{IFS}$ $\overline{IRQx}^1$ or FI Setup Before CLKOUT Low <sup>2,3</sup>	44.4		39.2		35.0		$0.25t_{CK} + 20$		ns
$t_{IFH}$ $\overline{IRQx}^1$ or FI Hold After CLKOUT High <sup>2,3</sup>	24.4		19.2		15.0		$0.25t_{CK}$		ns
<i>Switching Characteristics:</i>									
$t_{FOH}$ FO Hold After CLKOUT High	0		0		0		0		ns
$t_{FOD}$ FO Delay from CLKOUT High		15		15		15		15	ns

#### NOTES

<sup>1</sup> $\overline{IRQx} = \overline{IRQ0}, \overline{IRQ1}, \text{ and } \overline{IRQ2}.$

<sup>2</sup>If  $\overline{IRQx}$  and FI inputs meet  $t_{IFS}$  and  $t_{IFH}$  setup/hold requirements, they will be recognized during the current clock cycle; otherwise they will be recognized during the following cycle. (Refer to the "Interrupt Controller" section in Chapter 3, Program Control, of the *ADSP-2100 Family User's Manual*, Third Edition, for further information on interrupt servicing.)

<sup>3</sup>Edge-sensitive interrupts require pulse widths greater than 10 ns. Level-sensitive interrupts must be held low until serviced.

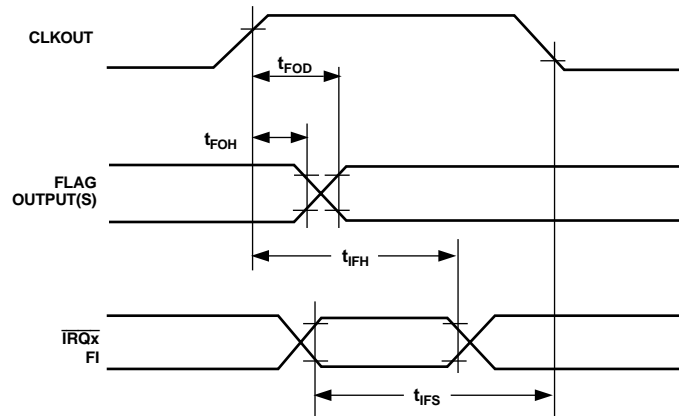

Figure 28. Interrupts and Flags

**TIMING PARAMETERS (ADSP-2162/ADSP-2164/ADSP-2166)**

**BUS REQUEST/BUS GRANT**

Parameter	10.24 MHz		13.0 MHz		16.67 MHz		Frequency Dependency		Unit
	Min	Max	Min	Max	Min	Max	Min	Max	
<i>Timing Requirements:</i>									
$t_{BH}$ $\overline{BR}$ Hold After CLKOUT High <sup>1</sup>	29.4		24.2		20.0		$0.25t_{CK} + 5$		ns
$t_{BS}$ $\overline{BR}$ Setup Before CLKOUT Low <sup>1</sup>	44.4		39.2		35.0		$0.25t_{CK} + 20$		ns
<i>Switching Characteristics:</i>									
$t_{SD}$ CLKOUT High to $\overline{DMS}$ , $\overline{PMS}$ , $\overline{BMS}$ , $\overline{RD}$ , $\overline{WR}$ Disable		44.4		39.2		35.0		$0.25t_{CK} + 20$	ns
$t_{SDB}$ $\overline{DMS}$ , $\overline{PMS}$ , $\overline{BMS}$ , $\overline{RD}$ , $\overline{WR}$ Disable to $\overline{BG}$ Low	0		0		0		0		ns
$t_{SE}$ $\overline{BG}$ High to $\overline{DMS}$ , $\overline{PMS}$ , $\overline{BMS}$ , $\overline{RD}$ , $\overline{WR}$ Enable	0		0		0		0		ns
$t_{SEC}$ $\overline{DMS}$ , $\overline{PMS}$ , $\overline{BMS}$ , $\overline{RD}$ , $\overline{WR}$ Enable to CLKOUT High	14.4		9.2		5.0		$0.25t_{CK} - 10$		ns

NOTES

<sup>1</sup>If  $\overline{BR}$  meets the  $t_{BS}$  and  $t_{BH}$  setup/hold requirements, it will be recognized in the current processor cycle; otherwise it is recognized in the following cycle.  $\overline{BR}$  requires a pulsewidth greater than 10 ns.

Section 10.2.4, “Bus Request/Grant,” of the *ADSP-2100 Family User’s Manual*, Third Edition, states that, “When  $\overline{BR}$  is recognized, the processor responds immediately by asserting  $\overline{BG}$  during the same cycle.” This is incorrect for the current versions of all ADSP-21xx processors:  $\overline{BG}$  is asserted in the cycle *after*  $\overline{BR}$  is recognized. No external synchronization circuit is needed when  $\overline{BR}$  is generated as an asynchronous signal.

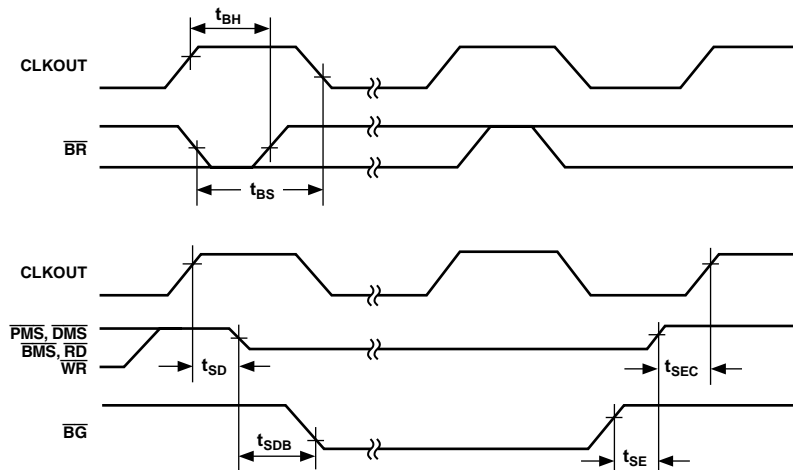

Figure 29. Bus Request/Grant

# ADSP-216x

## TIMING PARAMETERS (ADSP-2162/ADSP-2164/ADSP-2166)

### MEMORY READ

Parameter	10.24 MHz		13.0 MHz		16.67 MHz		Frequency Dependency		Unit
	Min	Max	Min	Max	Min	Max	Min	Max	
<i>Timing Requirements:</i>									
$t_{RDD}$ $\overline{RD}$ Low to Data Valid		33.8		23.5		15		$0.5t_{CK} - 15 + w$	ns
$t_{AA}$ A0-A13, $\overline{PMS}$ , $\overline{DMS}$ , $\overline{BMS}$ to Data Valid		49.2		33.7		21		$0.75t_{CK} - 24 + w$	ns
$t_{RDH}$ Data Hold from $\overline{RD}$ High	0		0		0		0		ns
<i>Switching Characteristics:</i>									
$t_{RP}$ $\overline{RD}$ Pulsewidth	43.8		33.25		25		$0.5t_{CK} - 5 + w$		ns
$t_{CRD}$ CLKOUT High to $\overline{RD}$ Low	19.4	34.4	14.2	29.2	10.0	25.0	$0.25t_{CK} - 5$	$0.25t_{CK} + 10$	ns
$t_{ASR}$ A0-A13, $\overline{PMS}$ , $\overline{DMS}$ , $\overline{BMS}$ Setup Before $\overline{RD}$ Low	12.4		7.2		3.0		$0.25t_{CK} - 12$		ns
$t_{RDA}$ A0-A13, $\overline{PMS}$ , $\overline{DMS}$ , $\overline{BMS}$ Hold After $\overline{RD}$ Deasserted	14.4		9.2		5.0		$0.25t_{CK} - 10$		ns
$t_{RWR}$ $\overline{RD}$ High to $\overline{RD}$ or $\overline{WR}$ Low	38.8		28.5		20.0		$0.5t_{CK} - 10$		ns

w = wait states  $\times t_{CK}$ .

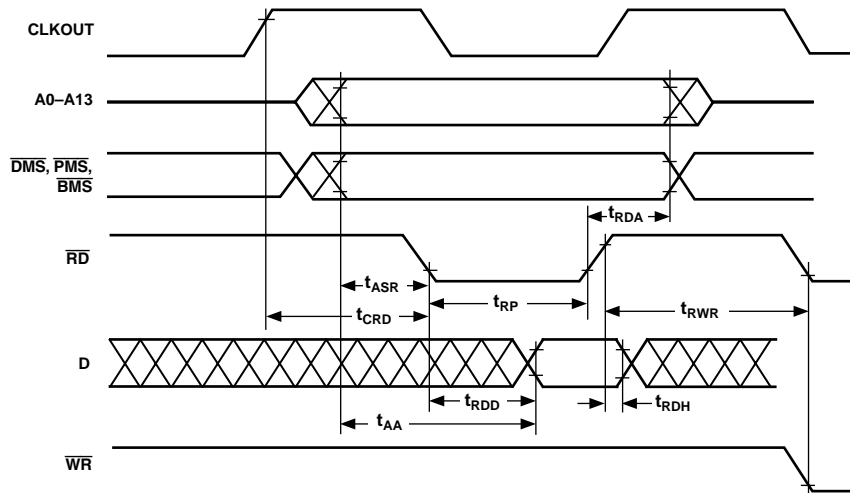

Figure 30. Memory Read

**TIMING PARAMETERS (ADSP-2162/ADSP-2164/ADSP-2166)**

**MEMORY WRITE**

Parameter	10.24 MHz		13.0 MHz		16.67 MHz		Frequency Dependency		Unit	
	Min	Max	Min	Max	Min	Max	Min	Max		
<i>Switching Characteristics:</i>										
t <sub>DW</sub>	Data Setup Before $\overline{WR}$ High		28.25		20		0.5t <sub>CK</sub> - 10 + w		ns	
t <sub>DH</sub>	Data Hold After $\overline{WR}$ High		9.2		5.0		0.25t <sub>CK</sub> - 10		ns	
t <sub>WP</sub>	$\overline{WR}$ Pulsewidth		33.25		25		0.5t <sub>CK</sub> - 5 + w		ns	
t <sub>WDE</sub>	$\overline{WR}$ Low to Data Enabled		0		0		0			
t <sub>ASW</sub>	A0-A13, $\overline{DMS}$ , $\overline{PMS}$ Setup Before $\overline{WR}$ Low		7.2		3.0		0.25t <sub>CK</sub> - 12		ns	
t <sub>DDR</sub>	Data Disable Before $\overline{WR}$ or $\overline{RD}$ Low		14.4		5.0		0.25t <sub>CK</sub> - 10		ns	
t <sub>CWR</sub>	CLKOUT High to $\overline{WR}$ Low		19.4 34.4		10.0 25.0		0.25t <sub>CK</sub> - 5 0.25t <sub>CK</sub> + 10		ns	
t <sub>AW</sub>	A0-A13, $\overline{DMS}$ , $\overline{PMS}$ , Setup Before $\overline{WR}$ Deasserted		42.7		30		0.75t <sub>CK</sub> - 15 + w		ns	
t <sub>WRA</sub>	A0-A13, $\overline{DMS}$ , $\overline{PMS}$ Hold After $\overline{WR}$ Deasserted		14.4		5.0		0.25t <sub>CK</sub> - 10		ns	
t <sub>WWR</sub>	$\overline{WR}$ High to $\overline{RD}$ or $\overline{WR}$ Low		28.25		20		0.5t <sub>CK</sub> - 10		ns	

w = wait states × t<sub>CK</sub>.

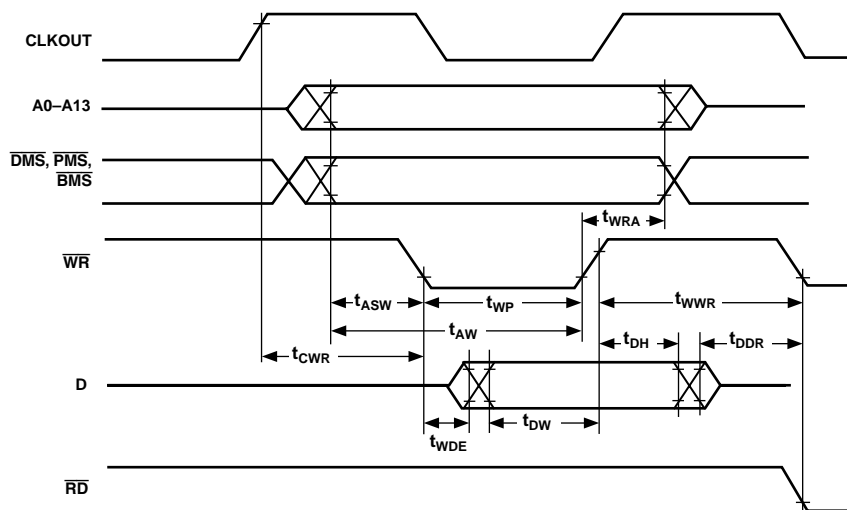

Figure 31. Memory Write

# ADSP-216x

## TIMING PARAMETERS (ADSP-2162/ADSP-2164/ADSP-2166)

### SERIAL PORTS

Parameter	10.24 MHz		13.0 MHz		13.824 MHz <sup>1</sup>		Frequency Dependency		Unit
	Min	Max	Min	Max	Min	Max	Min	Max	
<i>Timing Requirements:</i>									
$t_{SCK}$ SCLK Period	97.6		76.9		72.3 <sup>1</sup>		$t_{CK}$ <sup>1</sup>		ns
$t_{SCS}$ DR/TFS/RFS Setup Before SCLK Low	8		8		8		8		ns
$t_{SCH}$ DR/TFS/RFS Hold After SCLK Low	10		10		10		10		ns
$t_{SCP}$ SCLK <sub>IN</sub> Width	28		28		28		28		ns
<i>Switching Characteristics:</i>									
$t_{CC}$ CLKOUT High to SCLK <sub>OUT</sub>	24.4	39.4	19.2	34.2	18.1	33.1	$0.25t_{CK}$	$0.25t_{CK} + 15$	ns
$t_{SCDE}$ SCLK High to DT Enable	0		0		0		0		ns
$t_{SCDV}$ SCLK High to DT Valid		28 <sup>2</sup>		20		20		20 <sup>2</sup>	ns
$t_{RH}$ TFS/RFS <sub>OUT</sub> Hold After SCLK High	0		0		0		0		ns
$t_{RD}$ TFS/RFS <sub>OUT</sub> Delay from SCLK High		28 <sup>2</sup>		20		20		20 <sup>2</sup>	ns
$t_{SCDH}$ DT Hold After SCLK High	0		0		0		0		ns
$t_{TDE}$ TFS (Alt) to DT Enable	0		0		0		0		ns
$t_{TDV}$ TFS (Alt) to DT Valid		18		18		18		18	ns
$t_{SCDD}$ SCLK High to DT Disable		30 <sup>2</sup>		25		25		25 <sup>2</sup>	ns
$t_{RDV}$ RFS (Multichannel, Frame Delay Zero) to DT Valid		20		20		20		20	ns

#### NOTES

<sup>1</sup>Maximum serial port operating frequency is 13.824 MHz for all processor speed grades faster than 13.824 MHz.

<sup>2</sup>For 10.24 MHz only, the maximum frequency dependency for  $t_{SCDV} = 28$  ns,  $t_{RD} = 28$  ns,  $t_{SCDD} = 30$  ns.

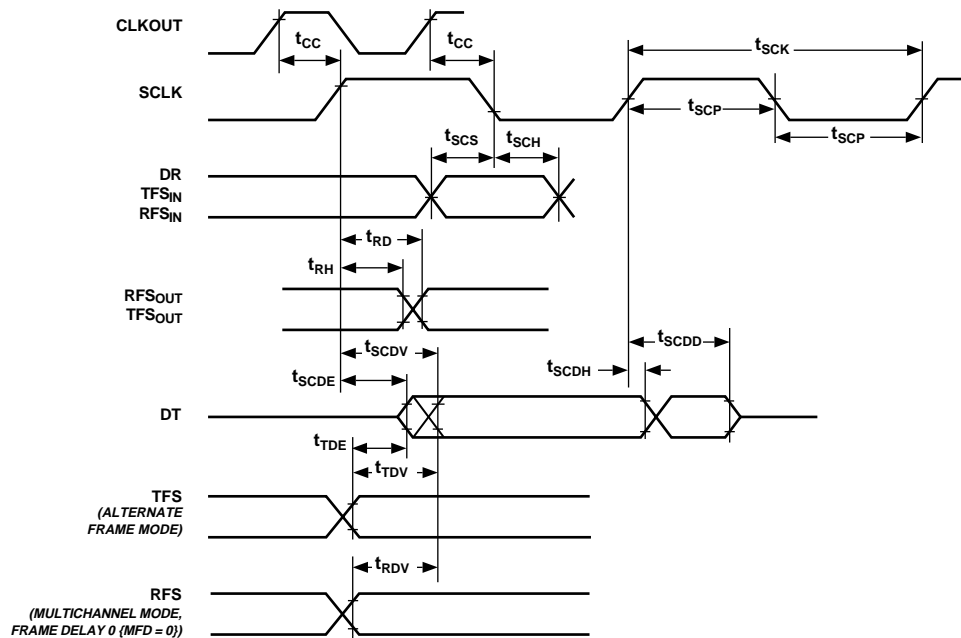
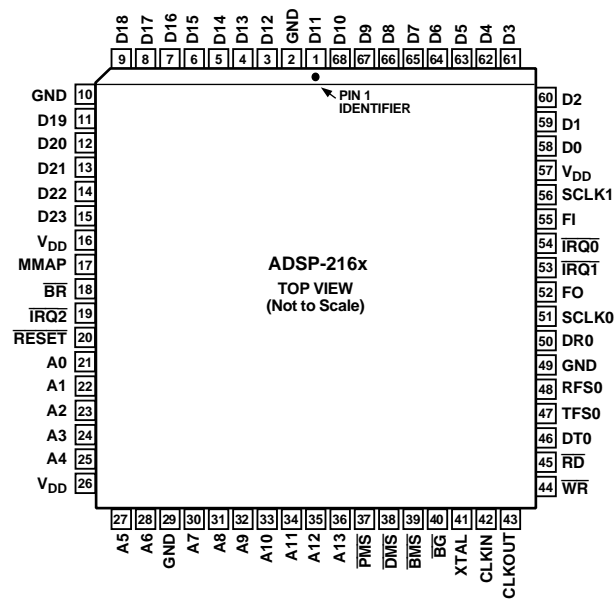

Figure 32. Serial Ports

## PIN CONFIGURATIONS 68-Lead PLCC



PLCC Number	Pin Name
1	D11
2	GND
3	D12
4	D13
5	D14
6	D15
7	D16
8	D17
9	D18
10	GND
11	D19
12	D20
13	D21
14	D22
15	D23
16	V <sub>DD</sub>
17	MMAP

PLCC Number	Pin Name
18	$\overline{\text{BR}}$
19	$\overline{\text{IRQ2}}$
20	$\overline{\text{RESET}}$
21	A0
22	A1
23	A2
24	A3
25	A4
26	V <sub>DD</sub>
27	A5
28	A6
29	GND
30	A7
31	A8
32	A9
33	A10
34	A11

PLCC Number	Pin Name
35	A12
36	A13
37	$\overline{\text{PMS}}$
38	$\overline{\text{DMS}}$
39	$\overline{\text{BMS}}$
40	BG
41	XTAL
42	CLKIN
43	CLKOUT
44	$\overline{\text{WR}}$
45	$\overline{\text{RD}}$
46	DT0
47	TFS0
48	RFS0
49	GND
50	DR0
51	SCLK0

PLCC Number	Pin Name
52	FO <i>(DT1)</i>
53	$\overline{\text{IRQ1}}$ <i>(TFS1)</i>
54	$\overline{\text{IRQ0}}$ <i>(RFS1)</i>
55	FI <i>(DR1)</i>
56	SCLK1
57	V <sub>DD</sub>
58	D0
59	D1
60	D2
61	D3
62	D4
63	D5
64	D6
65	D7
66	D8
67	D9
68	D10

# ADSP-216x

## PIN CONFIGURATIONS 80-Lead MQFP

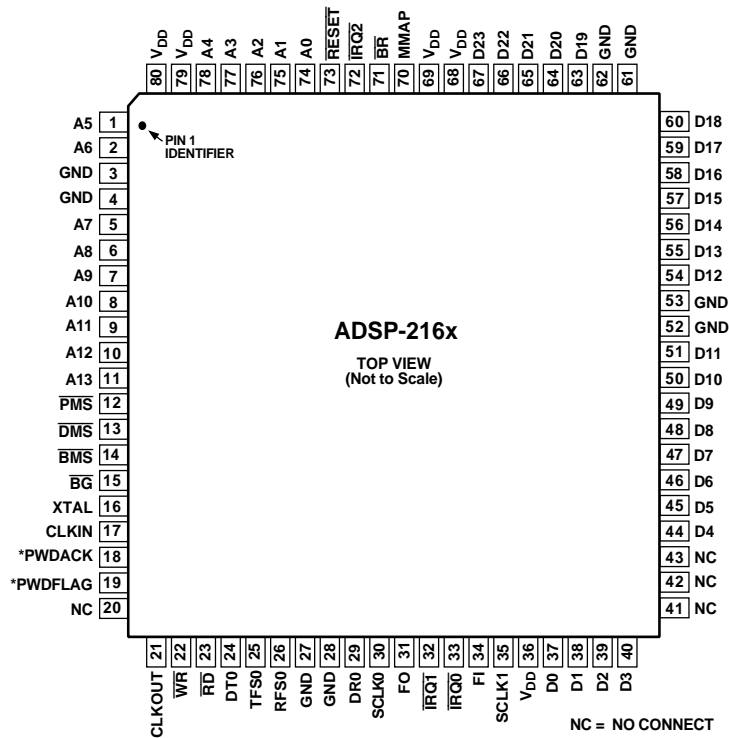

MQFP Number	Pin Name
1	A5
2	A6
3	GND
4	GND
5	A7
6	A8
7	A9
8	A10
9	A11
10	A12
11	A13
12	$\overline{\text{PMS}}$
13	$\overline{\text{DMS}}$
14	$\overline{\text{BMS}}$
15	$\overline{\text{BG}}$
16	XTAL
17	CLKIN
18	PWDACK*
19	PWDFLAG*
20	NC

MQFP Number	Pin Name
21	CLKOUT
22	$\overline{\text{WR}}$
23	$\overline{\text{RD}}$
24	DT0
25	TFS0
26	RFS0
27	GND
28	GND
29	DR0
30	SCLK0
31	FO ( <i>DT1</i> )
32	$\overline{\text{IRQ1}}$ ( <i>TFS1</i> )
33	$\overline{\text{IRQ0}}$ ( <i>RFS1</i> )
34	FI ( <i>DR1</i> )
35	SCLK1
36	V <sub>DD</sub>
37	D0
38	D1
39	D2
40	D3

MQFP Number	Pin Name
41	NC
42	NC
43	NC
44	D4
45	D5
46	D6
47	D7
48	D8
49	D9
50	D10
51	D11
52	GND
53	GND
54	D12
55	D13
56	D14
57	D15
58	D16
59	D17
60	D18

MQFP Number	Pin Name
61	GND
62	GND
63	D19
64	D20
65	D21
66	D22
67	D23
68	V <sub>DD</sub>
69	V <sub>DD</sub>
70	MMAP
71	$\overline{\text{BR}}$
72	$\overline{\text{IRQ2}}$
73	$\overline{\text{RESET}}$
74	A0
75	A1
76	A2
77	A3
78	A4
79	V <sub>DD</sub>
80	V <sub>DD</sub>

\*ADSP-2165/ADSP-2166 only.  
Others "NC".

OUTLINE DIMENSIONS

ADSP-216x  
68-Lead Plastic Leaded Chip Carrier (PLCC)

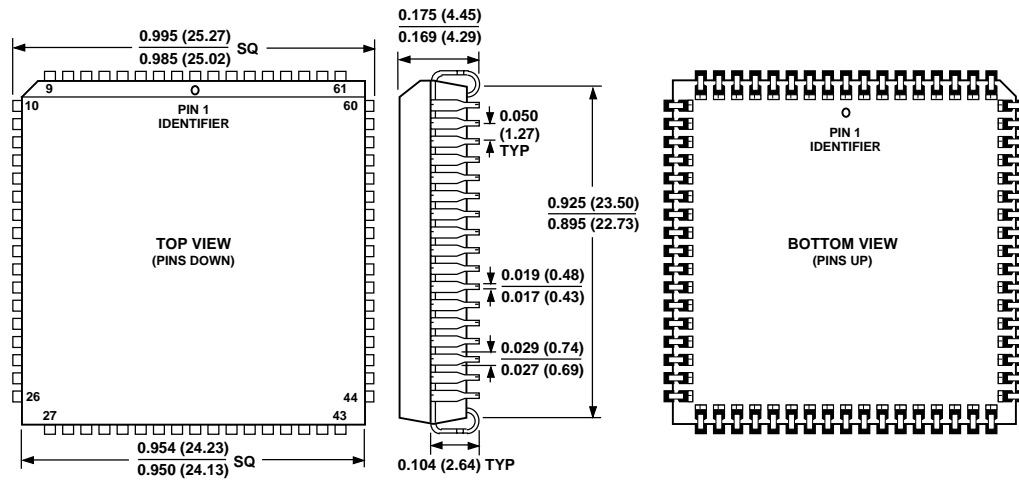

# ADSP-216x

## OUTLINE DIMENSIONS

### ADSP-216x 80-Lead Plastic Quad Flatpack (MQFP)

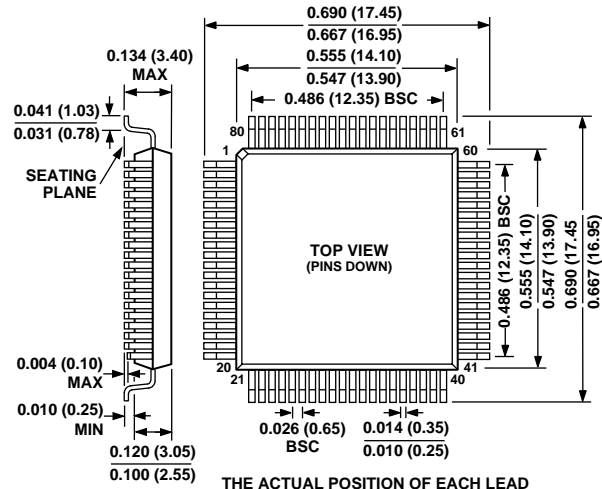

THE ACTUAL POSITION OF EACH LEAD IS WITHIN 0.0047 (0.12) FROM ITS IDEAL POSITION WHEN MEASURED IN THE LATERAL DIRECTION.

## ORDERING GUIDE

Part Number <sup>1</sup>	Ambient Temperature Range	Instruction Rate (MHz)	Package Description	Package Option
ADSP-2161KP-66 <sup>2</sup>	0°C to +70°C	16.67	68-Lead PLCC	P-68A
ADSP-2161BP-66 <sup>2</sup>	-40°C to +85°C	16.67	68-Lead PLCC	P-68A
ADSP-2161KS-66 <sup>2</sup>	0°C to +70°C	16.67	80-Lead MQFP	S-80
ADSP-2161BS-66 <sup>2</sup>	-40°C to +85°C	16.67	80-Lead MQFP	S-80
ADSP-2162KP-40 (3.3 V) <sup>2</sup>	0°C to +70°C	10.24	68-Lead PLCC	P-68A
ADSP-2162BP-40 (3.3 V) <sup>2</sup>	-40°C to +85°C	10.24	68-Lead PLCC	P-68A
ADSP-2162KS-40 (3.3 V) <sup>2</sup>	0°C to +70°C	10.24	80-Lead MQFP	S-80
ADSP-2163KP-66 <sup>2</sup>	0°C to +70°C	16.67	68-Lead PLCC	P-68A
ADSP-2163BP-66 <sup>2</sup>	-40°C to +85°C	16.67	68-Lead PLCC	P-68A
ADSP-2163KS-66 <sup>2</sup>	0°C to +70°C	16.67	80-Lead MQFP	S-80
ADSP-2163BS-66 <sup>2</sup>	-40°C to +85°C	16.67	80-Lead MQFP	S-80
ADSP-2163KP-100 <sup>2</sup>	0°C to +70°C	25	68-Lead PLCC	P-68A
ADSP-2163BP-100 <sup>2</sup>	-40°C to +85°C	25	68-Lead PLCC	P-68A
ADSP-2163KS-100 <sup>2</sup>	0°C to +70°C	25	80-Lead MQFP	S-80
ADSP-2163BS-100 <sup>2</sup>	-40°C to +85°C	25	80-Lead MQFP	S-80
ADSP-2164KP-40 (3.3 V) <sup>2</sup>	0°C to +70°C	10.24	68-Lead PLCC	P-68A
ADSP-2164BP-40 (3.3 V) <sup>2</sup>	-40°C to +85°C	10.24	68-Lead PLCC	P-68A
ADSP-2164KS-40 (3.3 V) <sup>2</sup>	0°C to +70°C	10.24	80-Lead MQFP	S-80
ADSP-2164BS-40 (3.3 V) <sup>2</sup>	-40°C to +85°C	10.24	80-Lead MQFP	S-80
ADSP-2165KS-80	0°C to +70°C	20.00	80-Lead MQFP	S-80
ADSP-2165KS-100	0°C to +70°C	25.00	80-Lead MQFP	S-80
ADSP-2165BS-80	-40°C to +85°C	20.00	80-Lead MQFP	S-80
ADSP-2165BS-100	-40°C to +85°C	25.00	80-Lead MQFP	S-80
ADSP-2166KS-52 (3.3 V)	0°C to +70°C	13.00	80-Lead MQFP	S-80
ADSP-2166KS-66 (3.3 V)	0°C to +70°C	16.67	80-Lead MQFP	S-80
ADSP-2166BS-52 (3.3 V)	-40°C to +85°C	13.00	80-Lead MQFP	S-80
ADSP-2166BS-66 (3.3 V)	-40°C to +85°C	16.67	80-Lead MQFP	S-80

## NOTES

<sup>1</sup>K = Commercial Temperature Range (0°C to +70°C).

B = Industrial Temperature Range (-40°C to +85°C).

P = PLCC (Plastic Leaded Chip Carrier).

S = MQFP (Plastic Quad Flatpack).

<sup>2</sup>Minimum order quantities required. Contact factory for further information.

<sup>3</sup>Refer to the section titled "Ordering Procedure for ROM-Coded ADSP-216x Processors" for information about ROM coded parts.



LittleDiode supplies new, hard to find or obsolete electronic components and semiconductors all over the world.

With over two million different components listed you are sure to find the part you need.

Feel free to visit us today at our online store:

[LittleDiode.com](http://LittleDiode.com)

Looking forward to providing you with the best possible service.