

Preliminary Technical Data ADSP-21mod980N

PERFORMANCE FEATURES

- Complete Single Device Multi-Port Internet Gateway Processor (No External Memory Required)
- Implements Sixteen Modem Channels or Forty Voice Channels in One Package
- Each DSP Can Implement two V.34/V.90 Data/Fax Modem Channels (includes Datapump and Controller)
- Low Power Version: 640 MIPS Sustained Performance, 12.5 ns Instruction Time @ 1.9 Volts nominal (internal)
- Open Architecture Extensible to Voice-over-Network (VoN) and Other Applications
- Low Power Dissipation, 25 mW (typical) per Channel
- Powerdown Mode Featuring Low CMOS Standby Power Dissipation

INTEGRATION FEATURES

- ADSP-2100 Family Code-Compatible, with Instruction Set Extensions
- 16 Mbits of On-Chip SRAM, Configured as 9 Mbits of Program Memory and 7 Mbits of Data Memory
- Dual-Purpose Program Memory, for Both Instruction and Data Storage
- 352-Ball PBGA with a 35mm × 35mm footprint

SYSTEM CONFIGURATION FEATURES

- 16-Bit Internal DMA Port for High-Speed Access to On-Chip Memory (Mode-Selectable)
- Programmable Multichannel Serial Port Supports 24/32 Channels
- Two Double-Buffered Serial Ports with Companding Hardware and Automatic Data Buffering
- Separate Reset Pins for Each Internal Processor

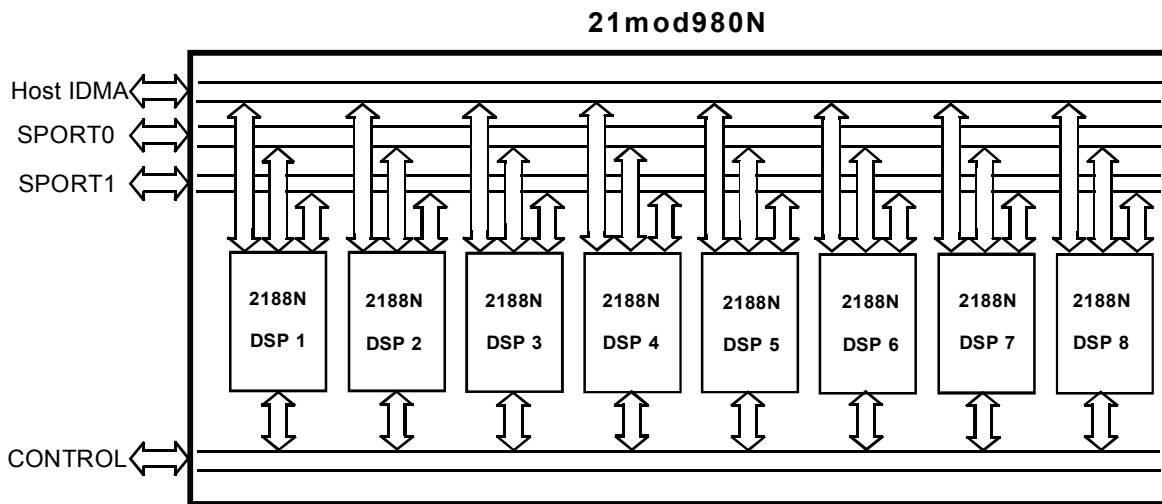

Figure 1. MOD980N MultiPort Internet Gateway Processor Block Diagram

REV. PrB 6/2001

This information applies to a product under development. Its characteristics and specifications are subject to change without notice. Analog Devices assumes no obligation regarding future manufacturing unless otherwise agreed to in writing.

One Technology Way, P.O.Box 9106, Norwood, MA 02062-9106, U.S.A.
 Tel: 781/329-4700 World Wide Web Site: <http://www.analog.com>
 Fax: 781/326-8703 ©Analog Devices, Inc., 2001

ADSP-21mod980N For current information contact Analog Devices at (800) ANALOGD**GENERAL DESCRIPTION**

The ADSP-21mod980N is a multi-port Internet gateway processor optimized for implementation of a complete V.34/V.90 digital modem. All datapump and controller functions can be implemented on a single device, offering the lowest power consumption and highest possible modem port density.

The ADSP-21mod980N combines the ADSP-2100 Family base architecture (three computational units, data address generators, and a program sequencer) with two serial ports, a 16-bit internal DMA port, a byte DMA port, a programmable timer, Flag I/O, extensive interrupt capabilities, and on-chip program and data memory.

The ADSP-21mod980N integrates 16 Mbits of on-chip memory, configured as 384 Kwords (24-bit) of program RAM, and 448 Kwords (16-bit) of data RAM. Power-down circuitry is also provided to reduce the average and standby power consumption of equipment which in turn reduces equipment cooling requirements. The ADSP-21mod980N is available in a 35 mm x 35 mm, 352-lead PBGA package.

Fabricated in a high-speed, low-power, CMOS process, the ADSP-21mod980N operates with a 12.5 ns instruction cycle time. Every instruction can execute in a single processor cycle.

The ADSP-21mod980N's flexible architecture and comprehensive instruction set allow the processor to perform multiple operations in parallel. In one processor cycle, the ADSP-21mod980N can:

- Generate the next program address
- Fetch the next instruction
- Perform one or two data moves
- Update one or two data address pointers
- Perform a computational operation

This takes place while the processor continues to:

- Receive and transmit data through the two serial ports
- Receive and/or transmit data through the internal DMA port
- Receive and/or transmit data through the byte DMA port
- Decrement timer

MODEM SOFTWARE

The following software is available as object code from Analog Devices Inc.

- ADSP-21mod Family Dynamic Internet Voice Access™ (DIVA) Voice Over Network Solution.
- ADSP-21mod980-210N Multiport Internet Gateway Processor Modem Solution.

A complete system implementation requires the ADSP-21mod980N device plus modem or voice software.

The modem software executes general modem control, command sets, error correction, and data compression, data modulations (for example, V.34 and V.90), and host interface functions. The host interface allows system access to modem statistics, such as call progress, connect speed, retrain count, symbol rate, and other modulation parameters.

The modem datapump and controller software reside in on-chip SRAM and do not require additional memory. You can configure the ADSP-21mod980N dynamically by downloading software from the host through the 16-bit IDMA interface. This SRAM-based architecture provides a software upgrade path to other applications, such as voice-over-IP, and to future standards.

DEVELOPMENT SYSTEM

Analog Devices' wide range of software and hardware development tools supports the ADSP-21x N Series. The DSP tools include an integrated development environment (IDE), an evaluation kit, and a serial port emulator.

VisualDSP® is an integrated development environment, allowing for fast and easy development, debug and deployment. The VisualDSP project management environment lets programmers develop and debug an application. This environment includes an easy-to-use assembler that is based on an algebraic syntax; an archiver (librarian/library builder); a linker; a loader; a cycle-accurate, instruction-level simulator; a C compiler; and a C run-time library that includes DSP and mathematical functions.

Debugging both C and assembly programs with the VisualDSP debugger, programmers can:

- View mixed C and assembly code (interleaved source and object information)
- Insert break points
- Set conditional breakpoints on registers, memory, and stacks
- Trace instruction execution
- Fill and dump memory
- Source level debugging

The VisualDSP IDE lets programmers define and manage DSP software development. The dialog boxes and property pages let programmers configure and manage all of the ADSP-218x development tools, including the syntax highlighting in the VisualDSP editor. This capability controls how the development tools process inputs and generate outputs.

The ADSP-218x EZ-ICE[®] Emulator provides an easier and more cost-effective method for engineers to develop and optimize DSP systems, shortening product development cycles for faster time-to-market. The ADSP-21mod980N integrates on-chip emulation support with a 14-pin ICE-Port interface. This interface provides a simpler target board connection that requires fewer mechanical clearance considerations than other ADSP-2100 Family EZ-ICEs. The ADSP-21mod980N device need not be removed from the target system when using the EZ-ICE, nor are any adapters needed. Due to the small footprint of the EZ-ICE connector, emulation can be supported in final board designs. The EZ-ICE performs a full range of functions, including:

- In-target operation
- Up to 20 breakpoints
- Single-step or full-speed operation
- Registers and memory values can be examined and altered
- PC upload and download functions
- Instruction-level emulation of program booting and execution
- Complete assembly and disassembly of instructions
- C source-level debugging

ADDITIONAL INFORMATION

This data sheet provides a general overview of ADSP-21mod980N functionality. For specific information about the modem processors, refer to the ADSP-2188N data sheet. For additional information on the architecture and instruction set of the modem processors, refer to the ADSP-2100 Family User's Manual (3rd edition). For more information about the development tools, refer to the ADSP-2100 Family Development Tools Data Sheet.

ADSP-21mod980N For current information contact Analog Devices at (800) ANALOGD

ARCHITECTURE OVERVIEW

Figure 2 on page 4 is a functional block diagram of the ADSP-21mod980N. It contains eight independent digital signal processors.

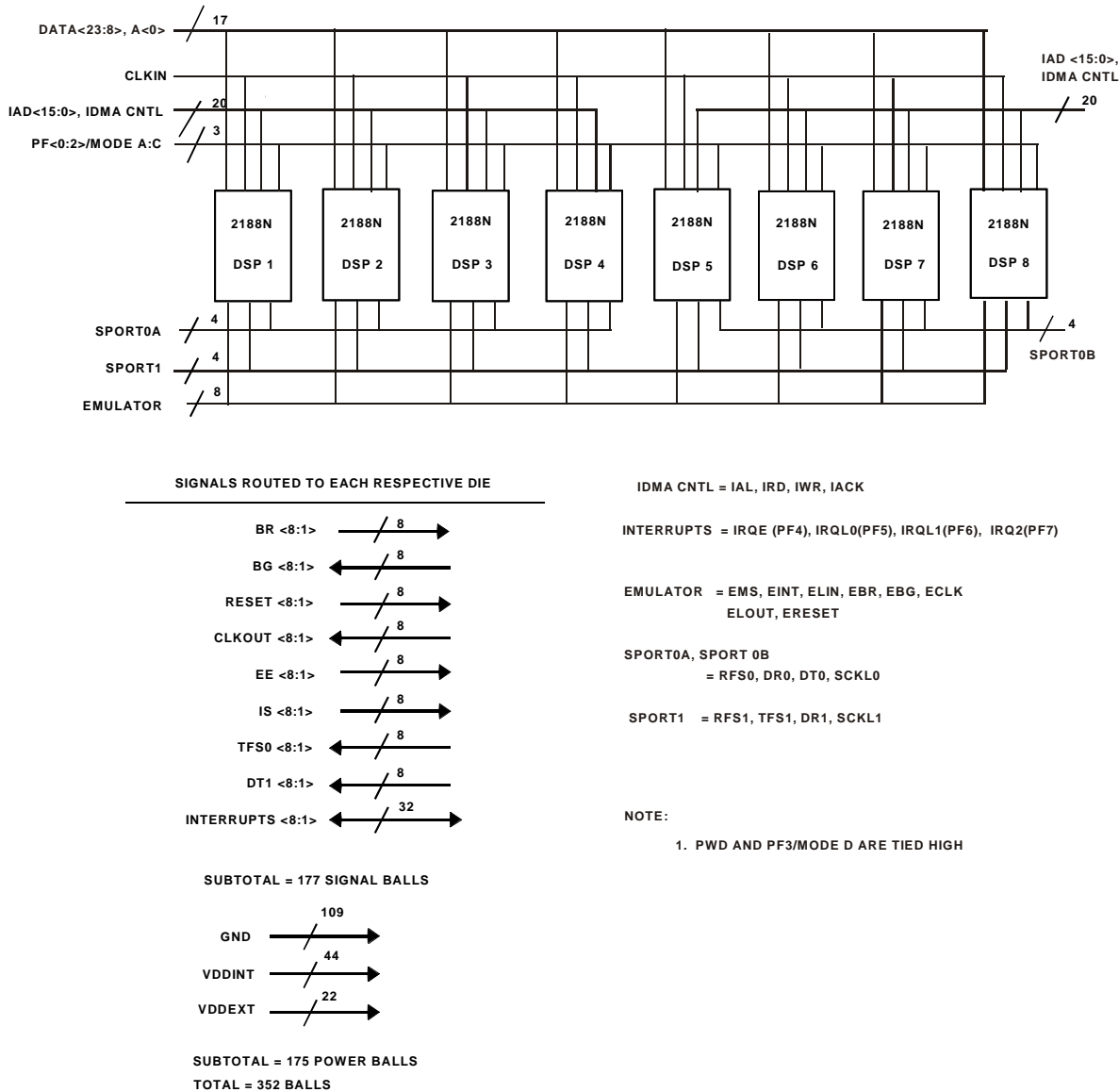

Figure 2. ADSP-21mod980N Functional Block Diagram

Every modem processor has:

- A DSP core
- 256K bytes of RAM
- Two serial ports
- An IDMA host.

The signals of each modem processor are accessed through the external pins of the ADSP-21mod980N. Some signals are bussed with the signals of the other processors and are

accessed through a single external pin. Other signals remain separate and they are accessed through separate external pins for each processor.

The arrangement of the eight modem processors in the ADSP-21mod980N makes one basic configuration possible: a *slave* configuration. In this configuration, the data pins of all eight processors connect to a single bus structure.

All eight modem processors have identical functions and have equal status. Each of the modem processors is connected to a common IDMA bus and each modem processor is configured to operate in the same mode (see the slave mode and the memory mode descriptions in “[Memory Architecture](#)” on page 10). The slave mode is considered to be the only mode of operation in the ADSP-21mod980N modem pool.

SERIAL PORTS

The ADSP-21mod980N has a multichannel serial port (SPORT) connected to each internal digital modem processor for serial communications.

The following is a brief list of ADSP-21mod980N SPORT features. For additional information on the internal Serial Ports, refer to the ADSP-2100 Family User’s Manual. Each SPORT:

- is bidirectional and has a separate, double-buffered transmit and receive section.
- can use an external serial clock or generate its own serial clock internally.
- has independent framing for the receive and transmit sections. Sections run in a frameless mode or with frame synchronization signals internally or externally generated. Frame sync signals are active high or inverted, with either of two pulse widths and timings.
- supports serial data word lengths from 3 to 16 bits and provides optional A-law and μ -law companding according to CCITT recommendation G.711.
- receive and transmit sections can generate unique interrupts on completing a data word transfer.
- can receive and transmit an entire circular buffer of data with one overhead cycle per data word. An interrupt is generated after a data buffer transfer.

A multichannel interface selectively receives and transmits a 24 or 32 word, time-division multiplexed, serial bitstream.

PIN DESCRIPTIONS

The ADSP-21mod980N is available in a 352-lead PBGA package. In order to maintain maximum functionality and reduce package size and pin count, some serial port, programmable flag, interrupt and external bus pins have dual, multiplexed functionality. The external bus pins are configured during $\overline{\text{RESET}}$ only, while serial port pins are software configurable during program execution. Flag and interrupt functionality is retained concurrently on multiplexed pins. [Table on page 6](#) lists the pin names and their functions. In cases where pin functionality is reconfigurable, the default state is shown in plain text; alternate functionality is shown in italics.

PRELIMINARY TECHNICAL DATA

ADSP-21mod980N For current information contact Analog Devices at (800) ANALOGD

Table 1. Common Mode Pins

Pin Name(s)	# of Pins	Input/Output	Function
$\overline{\text{RESET}}$	8	I	Processor Reset Input
$\overline{\text{BR}}$	8	I	Bus Request Input
$\overline{\text{BG}}$	8	O	Bus Grant Output
$\overline{\text{IRQ2}}$ / <i>PF7</i>	8 8	I I/O	Edge- or Level-Sensitive Interrupt Request ¹ <i>Programmable I/O Pin</i>
$\overline{\text{IRQ1}}$ / <i>PF6</i>	8 8	I I/O	Level-Sensitive Interrupt Requests ¹ <i>Programmable I/O Pin</i>
$\overline{\text{IRQL0}}$ / <i>PF5</i>	8 8	I I/O	Level-Sensitive Interrupt Requests ¹ <i>Programmable I/O Pin</i>
$\overline{\text{IRQE}}$ / <i>PF4</i>	8 8	I I/O	Edge-Sensitive Interrupt Requests ¹ <i>Programmable I/O Pin</i>
Mode C / <i>PF2</i>	1 1	I I/O	Mode Select Input - Checked Only During $\overline{\text{RESET}}$ <i>Programmable I/O Pin During Normal Operation</i>
Mode B / <i>PF1</i>	1 1	I I/O	Mode Select Input - Checked Only During $\overline{\text{RESET}}$ <i>Programmable I/O Pin During Normal Operation</i>
Mode A / <i>PF0</i>	1 1	I I/O	Mode Select Input - Checked Only During $\overline{\text{RESET}}$ <i>Programmable I/O Pin During Normal Operation</i>
CLKIN	1	I	Clock Input
CLKOUT	8	O	Processor Clock Output
SPORT	28	I/O	Serial Port I/O Pins ²
V _{DD} and GND	175	I	Power and Ground
EZ-Port	16	I/O	For Emulation Use

¹ Interrupt/Flag Pins retain both functions concurrently. If IMASK is set to enable the corresponding interrupts, then the ADSP-21mod980N will vector to the appropriate interrupt vector address when the pin is asserted, either by external devices, or set as a programmable flag.

² SPORT configuration determined by the ADSP-21mod980N System Control Register. Software configurable.

MEMORY INTERFACE PINS

The ADSP-21mod980N modem pool is used in Slave Mode. In Slave Mode, the Modem Processors operate in host configuration. The operating mode is determined by the state of the Mode C pin during $\overline{\text{RESET}}$ and cannot be changed while the modem pool is running. See the “Memory Architecture” section for more information.

PRELIMINARY TECHNICAL DATA

For current information contact Analog Devices at (800) ANALOGD

ADSP-21mod980N

Table 2. Host Pins (Mode C = 1) Modem Processors 1-8

Pin Name	# of Pins	Input/Output	Function
IAD[15:0]	32 ¹	I/O	IDMA Port Address/Data Bus
A0	1	O	Address Pin for External I/O, Program, Data, or Byte access
D[23:8]	16	I/O	Data I/O Pins for Program, Data Byte and I/O spaces
$\overline{\text{IWR}}$	2 ¹	I	IDMA Write Enable
$\overline{\text{IRD}}$	2 ¹	I	IDMA Read Enable
IAL	2 ¹	I	IDMA Address Latch Pin
$\overline{\text{IS}}$	8	I	IDMA Selects
$\overline{\text{IACK}}$	2 ¹	O	IDMA Port Acknowledge Configurable in Mode D; Open Drain

¹ There are two distinct IAD buses. One addresses DSPs 1-4 and the other communicates with DSPs 5-8. See Figure 2 for details.

INTERRUPTS

The interrupt controller allows each modem processor in the modem pool to respond individually to eleven possible interrupts and $\overline{\text{RESET}}$ with minimum overhead. The ADSP-21mod980N provides four dedicated external interrupt input pins, $\overline{\text{IRQ2}}$, $\overline{\text{IRQ1}}$, $\overline{\text{IRQ0}}$, and $\overline{\text{IRQE}}$ (shared with the PF[7:4] pins) for each modem processor. The ADSP-21mod980N also supports internal interrupts from the timer, the byte DMA port, the serial port, software, and the power-down control circuit. The interrupt levels are internally prioritized and individually maskable (except power down and $\overline{\text{RESET}}$). The $\overline{\text{IRQ2}}$, $\overline{\text{IRQ1}}$, and $\overline{\text{IRQ0}}$ input pins can be programmed to be either level- or edge-sensitive. $\overline{\text{IRQ0}}$ and $\overline{\text{IRQ1}}$ are level-sensitive and

$\overline{\text{IRQE}}$ is edge sensitive. The priorities and vector addresses of all interrupts are shown in Table on page 7. When the modem pool is reset, interrupt servicing is disabled.

Table 3. Interrupt Priority and Interrupt Vector Addresses

Source Of Interrupt	Interrupt Vector Address (Hex)
$\overline{\text{RESET}}$ (or Power-Up with PUCR = 1)	0x0000 (Highest Priority)
Power Down (Nonmaskable)	0x002C
$\overline{\text{IRQ2}}$	0x0004
$\overline{\text{IRQ1}}$	0x0008
$\overline{\text{IRQ0}}$	0x000C
SPORT0 Transmit	0x0010
SPORT0 Receive	0x0014
$\overline{\text{IRQE}}$	0x0018
BDMA Interrupt	0x001C
SPORT1 Transmit or $\overline{\text{IRQ1}}$	0x0020
SPORT1 Receive or $\overline{\text{IRQ0}}$	0x0024
Timer	0x0028 (Lowest Priority)

LOW POWER OPERATION

The ADSP-21mod980N has three low power modes that significantly reduce the power dissipation when the device operates under standby conditions. These modes are:

- Power Down
- Idle
- Slow Idle

The CLKOUT pin may also be disabled to reduce external power dissipation.

POWER DOWN

The ADSP-21mod980N modem pool has a low power feature that lets the modem pool enter a very low power dormant state through software control. Here is a brief list

ADSP-21mod980N

For current information contact Analog Devices at (800) ANALOGD

of power-down features. Refer to the ADSP-2100 Family User's Manual, "System Interface" chapter, for detailed information about the power-down feature.

- Quick recovery from power down. The modem pool begins executing instructions in as few as 200 CLKIN cycles.
- Support for an externally generated TTL or CMOS processor clock. The external clock can continue running during power down without affecting the lowest power rating and 200 CLKIN cycle recovery.
- Power down is initiated by the software power-down force bit. Interrupt support allows an unlimited number of instructions to be executed before optionally powering down.
- Context clear/save control allows the modem pool to continue where it left off or start with a clean context when leaving the power down state.
- The $\overline{\text{RESET}}$ pin also can be used to terminate power down.

IDLE

When the ADSP-21mod980N is in the Idle Mode, the modem pool waits indefinitely in a low power state until an interrupt occurs. When an unmasked interrupt occurs, it is serviced; execution then continues with the instruction following the IDLE instruction. In Idle mode IDMA, BDMA and autobuffer cycle steals still occur.

SLOW IDLE

The IDLE instruction is enhanced on the ADSP-21mod980N to let the modem pool's internal clock signal be slowed, further reducing power consumption. The reduced clock frequency, a programmable fraction of the normal clock rate, is specified by a selectable divisor given in the IDLE instruction.

The format of the instruction is:

IDLE (n);

where $n = 16, 32, 64,$ or 128 . This instruction keeps the modem pool fully functional, but operating at the slower clock rate. While it is in this state, the modem pool's other internal clock signals, such as SCLK, CLKOUT, and timer clock, are reduced by the same ratio. The default form of the instruction, when no clock divisor is given, is the standard IDLE instruction.

When the IDLE (n) instruction is used, it effectively slows down the modem pool's internal clock and thus its response time to incoming interrupts. The one-cycle response time of the standard idle state is increased by n , the clock divisor. When an enabled interrupt is received, the ADSP-21mod980N will remain in the idle state for up to a maximum of n modem pool cycles ($n = 16, 32, 64,$ or 128) before resuming normal operation.

When the IDLE (n) instruction is used in systems that have an externally generated serial clock (SCLK), the serial clock rate may be faster than the modem pool's reduced internal clock rate. Under these conditions, interrupts must not be generated at a faster rate than can be serviced, due to the additional time the modem pool takes to come out of the idle state (a maximum of n cycles).

SYSTEM CONFIGURATION

Figure on page 9 shows the hardware interfaces for a typical multichannel modem configuration with the ADSP-21mod980N. Other system design considerations such as host processing requirements, electrical loading, and overall bus timing must all be met. A line interface can be used to connect the multichannel subscriber or client data stream to the multichannel serial port of the ADSP-21mod980N. The IDMA port of the ADSP-21mod980N is used to give a host processor full access to the internal memory of the ADSP-21mod980N. This lets the host dynamically configure the ADSP-21mod980N by loading code and data into its internal memory. This configuration also lets the host access server data directly from the ADSP-21mod980N's internal memory. In this configuration, the Modem Processors should be put into host memory mode where Mode C = 1, Mode B = 0, and Mode A = 1.

ADSP-21mod980N

For current information contact Analog Devices at (800) ANALOGD

A clock output (CLKOUT) signal is generated by the processor at the processor's cycle rate. This can be enabled and disabled by the CLKODIS bit in the SPORT0 Autobuffer Control Register.

RESET

The $\overline{\text{RESET}}$ signals initiate a reset of each modem processor in the ADSP-21mod980N. The $\overline{\text{RESET}}$ signals must be asserted during the power-up sequence to assure proper initialization. $\overline{\text{RESET}}$ during initial power-up must be held long enough to let the internal clocks stabilize. If $\overline{\text{RESET}}$ s are activated any time after power up, the clocks continue to run and do not require stabilization time.

The power-up sequence is defined as the total time required for the oscillator circuits to stabilize after a valid V_{DD} is applied to the processors, and for the internal phase-locked loops (PLL) to lock onto the specific frequency. A minimum of 2000 CLKIN cycles ensures that the PLLs have locked, but this does not include the oscillators' start-up time. During this power-up sequence, the $\overline{\text{RESET}}$ signals should be held low. On any subsequent resets, the $\overline{\text{RESET}}$ signals must meet the minimum pulse width specification, t_{RSP} .

The $\overline{\text{RESET}}$ input contains some hysteresis; however, if you use an RC circuit to generate your $\overline{\text{RESET}}$ signals, the use of an external Schmidt triggers are recommended.

The $\overline{\text{RESET}}$ for each individual modem processor sets the internal stack pointers to the empty stack condition, masks all interrupts and clears the MSTAT register. When a $\overline{\text{RESET}}$ is released, if there is no pending bus request and the modem processor is configured for booting, the boot-loading sequence is performed. The first instruction is fetched from on-chip program memory location 0x0000 once boot loading completes.

MEMORY ARCHITECTURE

The ADSP-21mod980N provides a variety of memory and peripheral interface options for Modem Processor 1. The key functional groups are Program Memory, Data Memory, Byte Memory, and I/O. Refer to the following figures and tables for PM and DM memory allocations in the ADSP-21mod980N.

The ADSP-21mod980N modem pool operates in one memory mode: Slave Mode. The following figures and tables describe the memory of the ADSP-21mod980N:

- [Figure on page 10](#) shows Program Memory
- [Table on page 10](#) shows the generation of address bits based on the PMOVLAY values

- [Figure on page 11](#) shows Data Memory
- [Table on page 11](#) shows the generation of address bits based on the DMOVLAY values. Access to external memory is not available

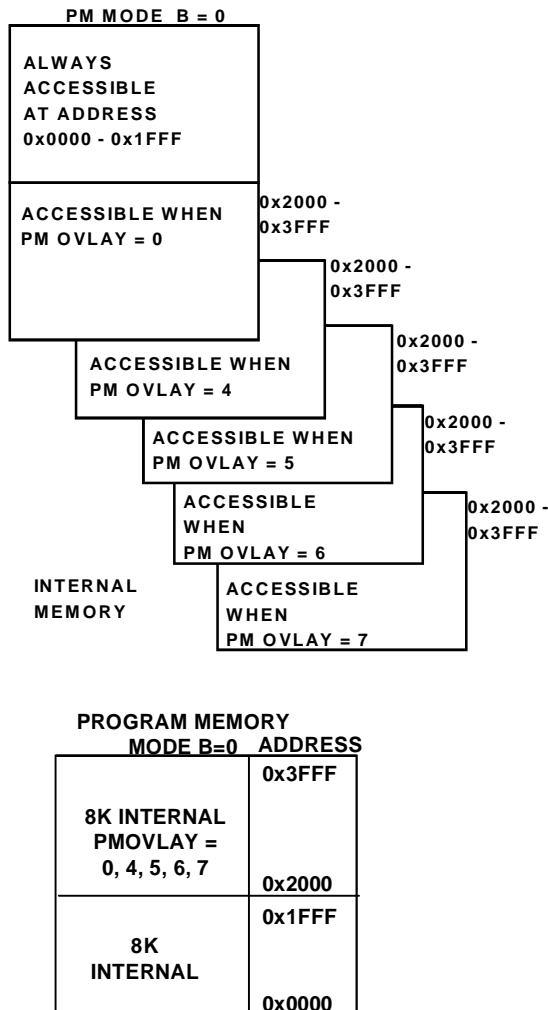

Figure 4. Program Memory Map

Table 4. PMOVLAY bits

PMOVLAY	Memory	A13	A[12:0]
0, 4, 5, 6, 7	Internal	Not Applicable	Not Applicable

PRELIMINARY TECHNICAL DATA

For current information contact Analog Devices at (800) ANALOGD

ADSP-21mod980N

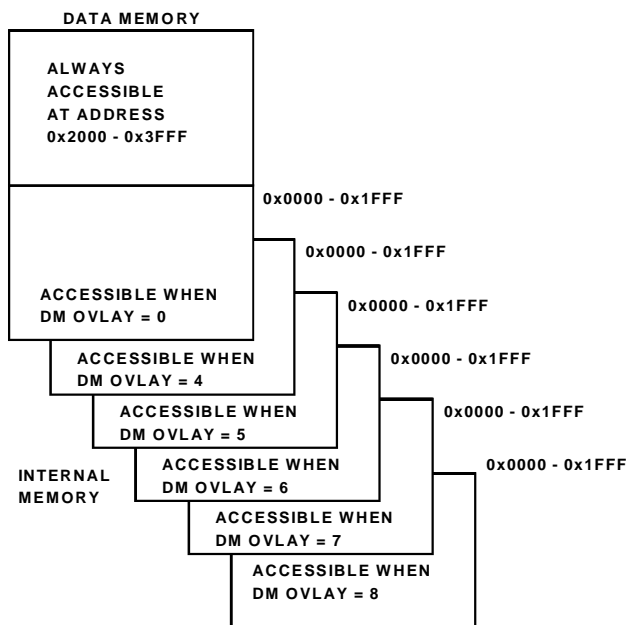

DATA MEMORY	ADDR
32 MEMORY MAPPED REGISTERS	0x3FFF 0x3FE0
INTERNAL 8160 WORDS	0x3FDF 0x2000
8K INTERNAL DMOVLAY = 0, 4, 5, 6, 7, 8	0x1FFF

Figure 5. Data Memory Map

Table 5. DMOVLAY bits

DMOVLAY	Memory	A13	A[12:0]
0, 4, 5, 6, 7, 8	Internal	Not Applicable	Not Applicable

MEMORY MAPPED REGISTERS (NEW TO THE ADSP-21MOD980N)

The ADSP-21mod980N has three memory mapped registers that differ from other ADSP-21xx Family DSPs. See "Waitstate Control Register" on page 11. See "Programmable Flag & Composite Select Control Register" on page 12. See "System Control Register" on page 12. The slight modifications to these registers provide the ADSP-21mod980N's waitstate and $\overline{\text{BMS}}$ control features.

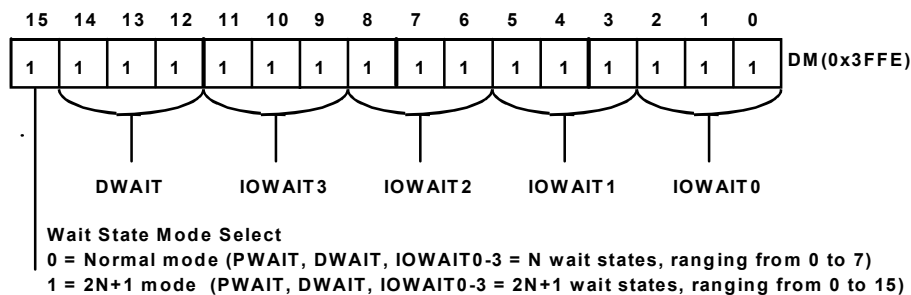

Figure 6. Waitstate Control Register

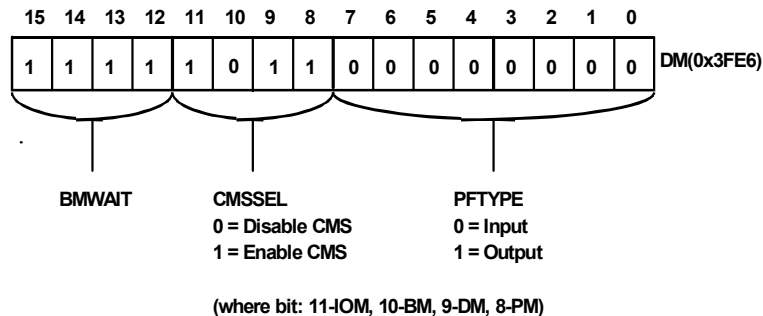

Figure 7. Programmable Flag¹ & Composite Select Control Register

¹ Since they are multiplexed within the ADSP-21mod980N, PF[2:0] should be configured as an output for only one processor at a time. Bit [3] of DM (0x3FE6) must also be 0 to ensure that PF[3] is never an output.

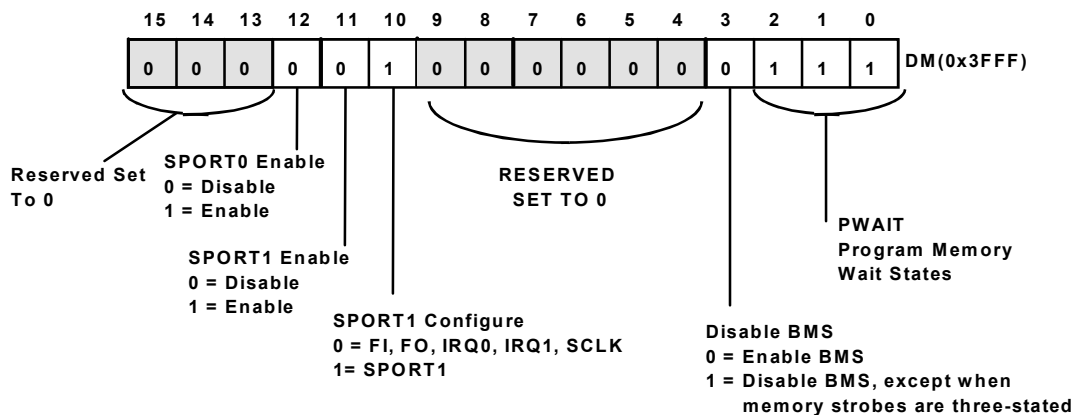

Figure 8. System Control Register

Table 6. ADSP-21mod980N Mode of Operation

MODE C	MODE B	MODE A	Booting Method
1	0	1	IDMA feature is used to load internal memory as desired. Program execution is held off until internal program memory location 0x0000 is written to. Chip is configured in Slave Mode. ¹ \overline{IACK} requires external pulldown. ²

¹ Considered standard operating settings. These configurations simplify your design and improve memory management.

² IDMA timing details and the correct usage of \overline{IACK} are described in the *ADSP-2100 Family User's Manual*.

SLAVE MODE

This section describes the Slave Mode memory configuration of the Modem Processors.

INTERNAL MEMORY DMA PORT (IDMA PORT)

The IDMA Port provides an efficient way for a host system and the ADSP-21mod980N to communicate. The port is used to access the on-chip program memory and data memory of each modem processor with only one processor cycle per word overhead. The IDMA port cannot be used, how-

ever, to write to the processor's memory-mapped control registers. A typical IDMA transfer process is described as follows:

1. Host starts IDMA transfer
2. Host uses \overline{IS} and IAL control lines to latch either the DMA starting address (IDMAA) or the PM/DM OVLAY selection into the processor's IDMA control registers.

If IAD [15] = 1, the value of IAD [7:0] represents the IDMA overlay: IAD[14:8] must be set to 0.

If IAD [15] = 0, the value of IAD [13:0] represents the starting address of internal memory to be accessed and IAD [14] reflects PM or DM for access.

1. Host uses \overline{IS} and \overline{IRD} (or \overline{IWR}) to read (or write) processor internal memory (PM or DM).
2. Host ends IDMA transfer.

The IDMA port has a 16-bit multiplexed address and data bus and supports 24-bit program memory. The IDMA port is completely asynchronous and can be written to, while the ADSP-21mod980N is operating at full speed.

The processor memory address is latched and then automatically incremented after each IDMA transaction. An external device can therefore access a block of sequentially addressed memory by specifying only the starting address of the block. This increases throughput as the address does not have to be sent for each memory access.

IDMA Port access occurs in two phases. The first is the *IDMA Address Latch cycle*. When the acknowledge is asserted, a 14-bit address and 1-bit destination type can be driven onto the bus by an external device. The address

specifies an on-chip memory location, the destination type specifies whether it is a DM or PM access. The falling edge of the address latch signal latches this value into the IDMAA register.

Once the address is stored, data can then be either read from, or written to, the ADSP-21mod980N's on-chip memory. Asserting the select line (\overline{IS}) and the appropriate read or write line (\overline{IRD} and \overline{IWR} respectively) signals the ADSP-21mod980N that a particular transaction is required. In either case, there is a one-processor-cycle delay for synchronization. The memory access consumes one additional processor cycle.

Once an access has occurred, the latched address is automatically incremented, and another access can occur.

Through the IDMAA register, the processor can also specify the starting address and data format for DMA operation. Asserting the IDMA port select (\overline{IS}) and address latch enable (IAL) directs the ADSP-21mod980N to write the address onto the IAD [14:0] bus into the IDMA Control Register. If IAD [15] is set to 0, IDMA latches the address. If IAD [15] is set to 1, IDMA latches OVLAY memory. The IDMAA register is memory mapped at address DM (0x3FE0). Note that the latched address (IDMAA) or overlay register cannot be read back by the host. The IDMA OVERLAY register is memory mapped at address DM(0x3FE7). See [Figure on page 13](#) for more information on IDMA memory mapping. When bit 14 in 0x3FE7 is set to 1, then timing in [Figure on page 35](#) applies for short reads. When bit 14 in 0x3FE7 is set to zero short reads use the timing shown in [Figure on page 34](#).

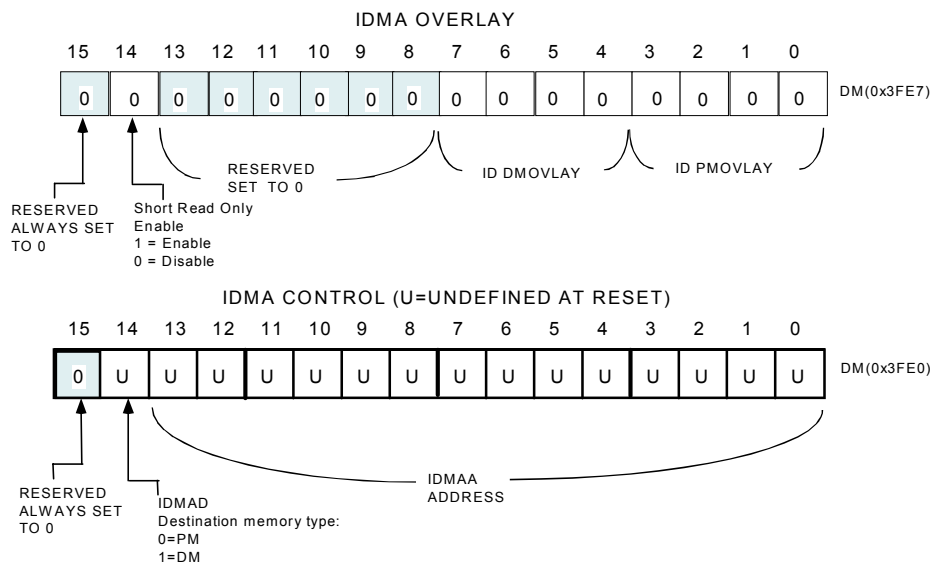

Figure 9. IDMA Control/OVLAY Registers

PRELIMINARY TECHNICAL DATA

ADSP-21mod980N For current information contact Analog Devices at (800) ANALOGD

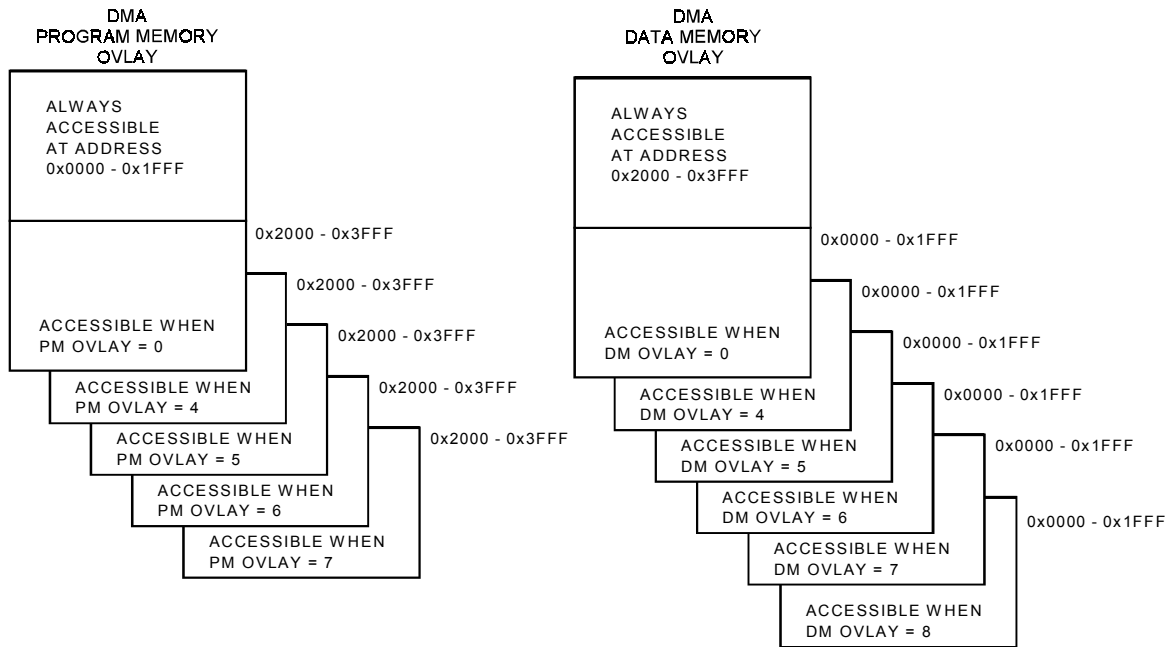

Figure 10. Direct Memory Access - PM and DM Memory Maps

IDMA PORT BOOTING

The ADSP-21mod980N boots programs through its Internal DMA port. When Mode C = 1, Mode B = 0, and Mode A = 1, the ADSP-21mod980N boots from the IDMA port. IDMA feature can load as much on-chip memory as desired. Program execution is held off until on-chip program memory location 0 is written to.

FLAG I/O PINS

Each modem processor has eight general purpose programmable input/output flag pins. They are controlled by two memory mapped registers. The PFTYPE register determines the direction, 1 = output and 0 = input. The PFDATA register is used to read and write the values on the pins. Data being read from a pin configured as an input is synchronized to the ADSP-21mod980N's clock. Bits that are programmed as outputs will read the value being output. The PF pins default to input during $\overline{\text{RESET}}$.

Note: Pins PF0, PF1, and PF2 are also used for device configuration during $\overline{\text{RESET}}$. Since they are multiplexed within the ADSP-21mod980N, PF[2:0] should be configured as an output for only one processor at a time.

ADSP-21mod980N

For current information contact Analog Devices at (800) ANALOGD

DESIGNING AN EZ-ICE-COMPATIBLE SYSTEM

The ADSP-21mod980N has on-chip emulation support and an ICE-Port, a special set of pins that interface to the EZ-ICE. These features allow in-circuit emulation without replacing the target system processor by using only a 14-pin connection from the target system to the EZ-ICE. Target systems must have a 14-pin connector to accept the EZ-ICE's in-circuit probe, a 14-pin plug.

The EZ-ICE can emulate only one modem processor at a time. You must include hardware to select which processor in the ADSP-21mod980N you want to emulate. [Figure on page 16](#) is a functional representation of the modem processor selection hardware. You can use one ICE-Port connector with two ADSP-21mod980N processors without using additional buffers.

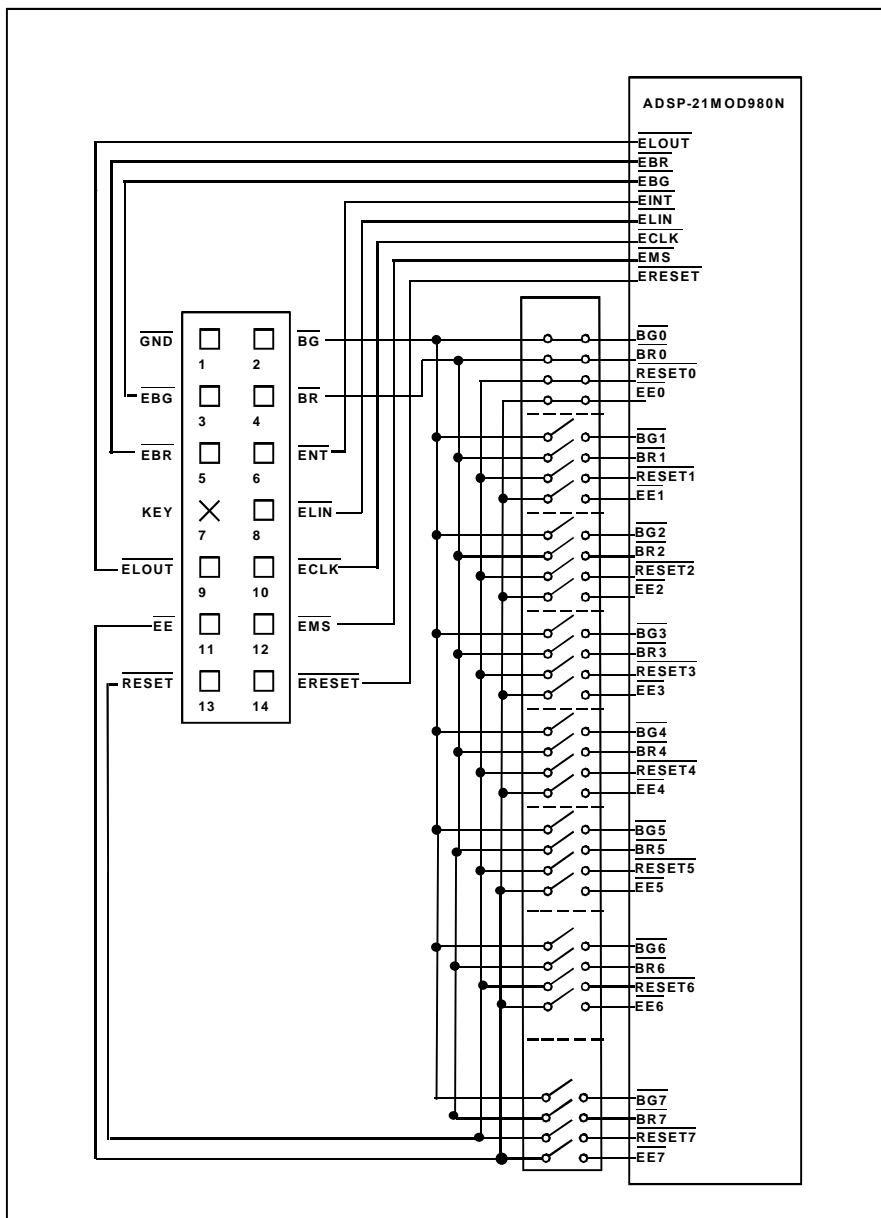

Figure 11. Selecting a Modem Processor in the ADSP-21mod980N

Issuing the “chip reset” command during emulation causes the modem processor to perform a full chip reset, including a reset of its memory mode. Therefore, it is vital that the

mode pins are set correctly PRIOR to issuing a chip reset command from the emulator user interface. As the mode pins share functionality with PF[2:0] on the

ADSP-21mod980N, it may be necessary to reset the target hardware separately to insure the proper mode selection state on emulator chip reset. See the ADSP-2100 Family EZ-Tools data sheet for complete information on ICE products.

The ICE-Port interface consists of the following ADSP-21mod980N pins:

$\overline{\text{EBR}}$
 $\overline{\text{EINT}}$
 EE
 $\overline{\text{EBG}}$
 ECLK
 $\overline{\text{ERESET}}$
 ELIN
 $\overline{\text{EMS}}$
 ELOUT

These ADSP-21mod980N pins must be connected only to the EZ-ICE connector in the target system. These pins have no function except during emulation, and do not require pull-up or pull-down resistors. The traces for these signals between the ADSP-21mod980N and the connector must be kept as short as possible—no longer than 3 inches.

The following pins are also used by the EZ-ICE:

- $\overline{\text{BR}}$
- $\overline{\text{BG}}$
- $\overline{\text{RESET}}$
- GND

The EZ-ICE uses the EE (emulator enable) signal to take control of the ADSP-21mod980N in the target system. This causes the processor to use its $\overline{\text{ERESET}}$, $\overline{\text{EBR}}$, and $\overline{\text{EBG}}$ pins instead of the $\overline{\text{RESET}}$, $\overline{\text{BR}}$, and $\overline{\text{BG}}$ pins. The $\overline{\text{BG}}$ output is three-stated. These signals do not need to be jumper-isolated in your system.

The EZ-ICE connects to your target system via a ribbon cable and a 14-pin female plug. The female plug is plugged onto the 14-pin connector (a pin strip header) on the target board.

TARGET BOARD CONNECTOR FOR EZ-ICE PROBE

The EZ-ICE connector (a standard pin strip header) is shown in Figure on page 17. You must add this connector to your target board design if you intend to use the EZ-ICE. Be sure to allow enough room in your system to fit the EZ-ICE probe onto the 14-pin connector.

The 14-pin, 2-row pin strip header is keyed at the Pin 7 location—you must remove Pin 7 from the header. The pins must be 0.025 inch square and at least 0.20 inch in length.

Pin spacing should be 0.1 × 0.1 inches. The pin strip header must have at least 0.15 inch clearance on all sides to accept the EZ-ICE probe plug.

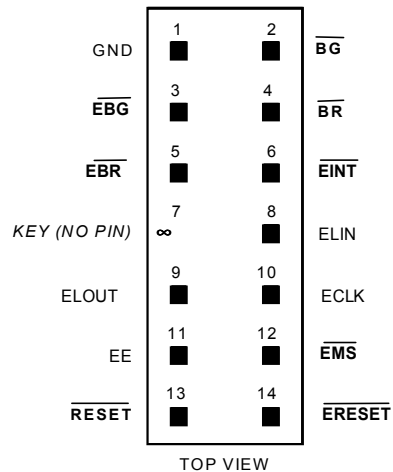

Figure 12. Target Board Connector for EZ-ICE

Pin strip headers are available from vendors such as 3M, McKenzie, and Samtec.

TARGET MEMORY INTERFACE

For your target system to be compatible with the EZ-ICE emulator, it must comply with the memory interface guidelines listed below.

TARGET SYSTEM INTERFACE SIGNALS

When the EZ-ICE board is installed, the performance on some system signals change. Design your system to be compatible with the following system interface signal changes introduced by the EZ-ICE board:

- EZ-ICE emulation introduces an 8 ns propagation delay between your target circuitry and the processor on the $\overline{\text{RESET}}$ signal.
- EZ-ICE emulation introduces an 8 ns propagation delay between your target circuitry and the processor on the $\overline{\text{BR}}$ signal.
- EZ-ICE emulation ignores $\overline{\text{RESET}}$ and $\overline{\text{BR}}$ when single-stepping.
- EZ-ICE emulation ignores $\overline{\text{RESET}}$ and $\overline{\text{BR}}$ when in Emulator Space (processor halted).
- EZ-ICE emulation ignores the state of target $\overline{\text{BR}}$ in certain modes. As a result, the target system may take control of the processor's external memory bus only if bus grant ($\overline{\text{BG}}$) is asserted by the EZ-ICE board's processor.

PRELIMINARY TECHNICAL DATA

ADSP-21mod980N For current information contact Analog Devices at (800) ANALOGD

ELECTRICAL SPECIFICATIONS

RECOMMENDED OPERATING CONDITIONS

Parameter	Description	Min	Max	Unit
V_{DDEXT}	External supply	2.98	3.63	V
V_{DDINT}	Internal supply	1.81	2.0	V
V_{INPUT}	Input Voltage	$V_{IL} = -0.3$	$V_{IH} = +3.6$	V
T_{AMB}	Ambient temperature	0	+70	°C

ELECTRICAL CHARACTERISTICS

Parameter	Test Conditions	Min	Typ	Max	Unit
V_{IH} , Hi-Level Input Voltage ^{1, 2}	@ $V_{DDINT} = \max$	1.5			V
V_{IH} , Hi-Level CLKIN Voltage	@ $V_{DDINT} = \max$	2.0			V
V_{IL} , Lo-Level Input Voltage ^{1, 3}	@ $V_{DDINT} = \min$			0.7	V
V_{OH} , Hi-Level Output Voltage ^{1, 4, 5}	@ $V_{DDEXT} = \min$ $I_{OH} = -0.5 \text{ mA}$	2.4			V
	@ $V_{DDEXT} = \min$ $I_{OH} = -100 \mu\text{A}$ ⁶	V_{DDEXT} -0.3			V
V_{OL} , Lo-Level Output Voltage ^{1, 4, 5}	@ $V_{DDEXT} = \min$ $I_{OL} = 2 \text{ mA}$			0.4	V
I_{IH} , Hi-Level Input Leakage Current ³	@ $V_{DDINT} = \max$ $V_{IN} = 3.6\text{V}$			10	μA
I_{IL} , Lo-Level Input Leakage Current ³	@ $V_{DDINT} = \max$ $V_{IN} = 0 \text{ V}$			10	μA
I_{OZH} , Three-State Leakage Current ⁷	@ $V_{DDEXT} = \max$ $V_{IN} = 3.6\text{V}$ ⁸			10	μA
I_{OZL} , Three-State Leakage Current ⁷	@ $V_{DDEXT} = \max$ $V_{IN} = 0 \text{ V}$ ⁸			10	μA

ELECTRICAL CHARACTERISTICS (CONTINUED)

Parameter	Test Conditions	Min	Typ	Max	Unit
I_{DD} , Supply Current (Idle)	@ $V_{DDINT} = 1.9V$ $t_{CK} = 12.5 ns$		50		mA
I_{DD} , Supply Current (Dynamic)	@ $V_{DDINT} = 1.9V$ $t_{CK} = 12.5 ns^9$ $T_{AMB} = +25^{\circ}C$		200		mA
I_{DD} , Supply Current (Powerdown) ¹⁰	Lowest power mode		800		μA
C_I , Input Pin Capacitance \overline{RESET} , \overline{BR} , \overline{IS} , TFS0, PF[7:4]	@ $V_{IN} = 2.5 V$, $f_{IN} = 1.0 MHz$, $T_{AMB} = +25^{\circ}C$			8	pF
C_I , Input Pin Capacitance \overline{IWR} , \overline{IRD} , IAL, DR0, RFS0, SCLK0, IAD [15:0]	@ $V_{IN} = 2.5 V$, $f_{IN} = 1.0 MHz$, $T_{AMB} = +25^{\circ}C$			32	pF
C_I , Input Pin Capacitance TFS1, PF[2:0], CLKIN, DR1, RFS1, SCLK1	@ $V_{IN} = 2.5 V$, $f_{IN} = 1.0 MHz$, $T_{AMB} = +25^{\circ}C$			64	pF
C_O , Output Pin Capacitance ^{1, 6, 7, 10, 11} \overline{BG} , CLKOUT, TFS0, PF[7:4], DT1	@ $V_{IN} = 2.5 V$, $f_{IN} = 1.0 MHz$, $T_{AMB} = +25^{\circ}C$			8	pF
C_O , Output Pin Capacitance ^{1, 6, 7, 9, 10} IAD [15:0], DT0, \overline{IACK} , RFS0, SCLK0	@ $V_{IN} = 2.5 V$, $f_{IN} = 1.0 MHz$, $T_{AMB} = +25^{\circ}C$			32	pF
C_O , Output Pin Capacitance ^{1, 6, 7, 9, 10} SCLK1, TFS1, PF[2:0], DATA [23:8], A0, RFS1	@ $V_{IN} = 2.5 V$, $f_{IN} = 1.0 MHz$, $T_{AMB} = +25^{\circ}C$			64	pF

¹ Bidirectional pins: RFS0, RFS1, SCLK0, SCLK1, TFS0, TFS1, IAD [15:0], PF[2:0], PF[7:4].

² Input only pins: \overline{RESET} , \overline{BR} , DR0, DR1, \overline{IS} , IAL, \overline{IRD} , \overline{IWR} .

³ Input only pins: CLKIN, \overline{RESET} , \overline{BR} , DR0, DR1.

⁴ Output pins: \overline{BG} , A0, DT0, DT1, CLKOUT, \overline{IACK} .

⁵ Although specified for TTL outputs, all ADSP-21mod980N outputs are CMOS-compatible and will drive to V_{DDEXT} and GND, assuming no DC loads.

⁶ Guaranteed but not tested.

⁷ Three-statable pins: DT0, DT1, SCLK0, SCLK1, TFS0, TFS1, RFS0, RFS1, IAD[15:0].

⁸ 0 Volts on \overline{BR} .

⁹ $V_{in} = 0V$ and $3V$. For typical supply current figures refer to "Power Dissipation" section.

¹⁰ See the *ADSP-2100 Family User's Manual* for details.

¹¹ Output pin capacitance is the capacitive load for any three-stated output pin

PRELIMINARY TECHNICAL DATA

ADSP-21mod980N For current information contact Analog Devices at (800) ANALOGD

ABSOLUTE MAXIMUM RATINGS

Parameter	Description	Min.	Max	Unit
V _{DDINT}	Internal Supply Voltage	-0.3	+2.5	V
V _{DDEXT}	External Supply Voltage	-0.3	+4.6	V
	Input Voltage ¹	-0.5	+4.6	V
	Output Voltage Swing ²	-0.5	V _{DDEXT} + 0.5	V
	Storage Temperature Range	-65 °C	+150 °C	°C

¹ Applies to bidirectional pins (D0:D23, RFS0, RFS1, SCLK0, SCLK1, TFS0, TFS1, A1:A13, PF0:PF7) and input only pins (CLKIN, RESET, BR, DR0, DR1).

² Applies to output pins ($\overline{\text{BG}}$, PWDACK, A0, DT0, DT1, CLKOUT).

ESD SENSITIVITY

CAUTION: ESD (electrostatic discharge) sensitive device. Electrostatic charges as high as 4000V readily accumulate on the human body and test equipment and can discharge without detection. Although the device features proprietary ESD protection circuitry, permanent damage may occur on devices subjected to high-energy electrostatic discharges. Therefore, proper ESD precautions are recommended to avoid performance degradation or loss of functionality.



POWER DISSIPATION

To determine total power dissipation in a specific application, the following equation should be applied for each output:

$$C \times V_{DD}^2 \times f$$

C = load capacitance

f = output switching frequency

Example:

In an application where an external host is accessing internal memory and no other outputs are active, power dissipation is calculated as follows:

Assumptions:

Assumptions:

- External data memory is accessed every fourth cycle with 50% of the address pins switching.
- External data memory writes occur every fourth cycle with 50% of the data pins switching.
- Each address and data pin has a 64 pF total load at the pin.
- Application operates at $V_{DDEXT} = 3.3 \text{ V}$ and $t_{CK} = 30 \text{ ns}$.

$$\text{Total Power Dissipation} = P_{INT} + (C \times V_{DDEXT}^2 \times f)$$

P_{INT} = internal power dissipation from [Figure 15](#)

$(C \times V_{DDEXT}^2 \times f)$ is calculated for each output, as in the example in [Table 7](#).

Table 7. Example Power Dissipation Calculation

Parameters	# of Pins	× C (pF)	× V_{DDEXT}^2 (V)	× f (MHz)	PD (mW)
Address	8	64	3.3^2	18.8	104.8
Data Output, \overline{WR}	9	64	3.3^2	18.8	117.9
					222.7

Total power dissipation for this example is:

$$PD = P_{INT} + 222.7 \text{ mW}$$

ENVIRONMENTAL CONDITIONS

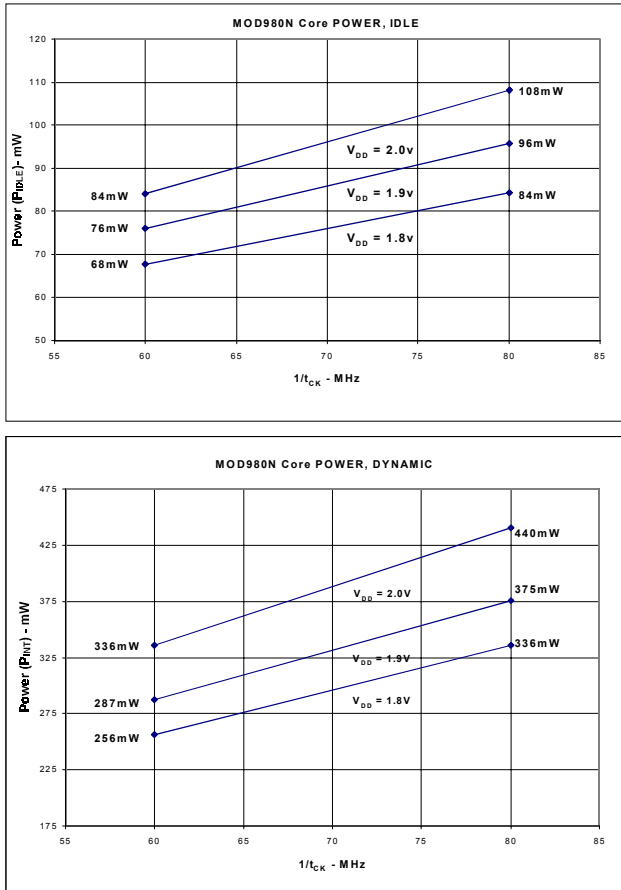

Figure 13. Power vs. Frequency

Table 8. Thermal Resistance

Rating Description ¹	Symbol	PBGA
Thermal Resistance (Case-to-Ambient)	θ_{CA}	23°C /W
Thermal Resistance (Junction-to-Ambient)	θ_{JA}	28.2°C /W
Thermal Resistance (Junction-to-Case)	θ_{JC}	5.2°C /W

¹ Where the Ambient Temperature Rating (T_{AMB}) is:
 $T_{AMB} = T_{CASE} - (PD \times \theta_{CA})$
 T_{CASE} = Case Temperature in °C
 PD = Power Dissipation in W

TEST CONDITIONS

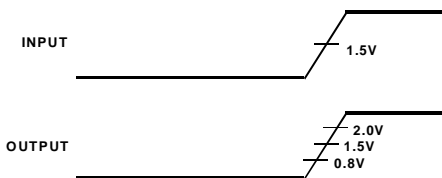

Figure 14. Voltage Reference Levels for AC Measurements (Except Output Enable/Disable)

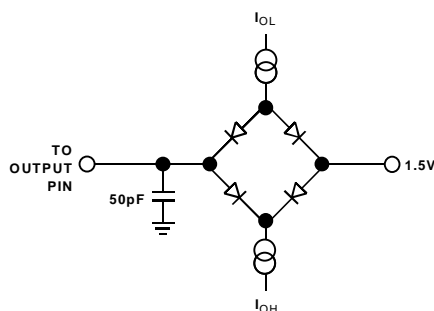

Figure 15. Equivalent Loading for AC Measurements (Including All Fixtures)

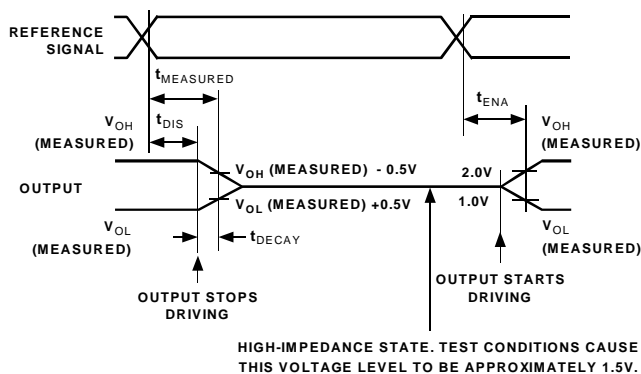

Figure 16. Output Enable/Disable

Output Disable Time

Output pins are considered to be disabled when they have stopped driving and started a transition from the measured output high or low voltage to a high impedance state. The output disable time (t_{DIS}) is the difference of $t_{MEASURED}$ and t_{DECAY} as shown in Figure 16. The time is the interval from when a reference signal reaches a high or low voltage level to when the output voltages have changed by 0.5 V from the measured output high or low voltage.

The decay time, t_{DECAY} is dependent on the capacitive load, C_L , and the current load, i_L , on the output pin. It can be approximated by the following equation:

$$t_{DECAY} = \frac{C_L \times 0.5V}{i_L}$$

from which

$$t_{DIS} = t_{MEASURED} - t_{DECAY}$$

is calculated. If multiple pins (such as the data bus) are disabled, the measurement value is that of the last pin to stop driving.

Output Enable Time

Output pins are considered to be enabled when they have made a transition from a high-impedance state to when they start driving. The output enable time (t_{ENA}) is the interval from when a reference signal reaches a high or low trip point, as shown in Figure 16. If multiple pins (such as the data bus) are enabled, the measurement value is that of the first pin to start driving.

ADSP-21mod980N

For current information contact Analog Devices at (800) ANALOGD

TIMING SPECIFICATIONS

This section contains timing information for the DSP's external signals.

General Notes

Use the exact timing information given. Do not attempt to derive parameters from the addition or subtraction of others. While addition or subtraction would yield meaningful results for an individual device, the values given in this data sheet reflect statistical variations and worst cases. Consequently, you cannot meaningfully add up parameters to derive longer times.

Timing Notes

Switching characteristics specify how the processor changes its signals. You have no control over this timing—circuitry external to the processor must be designed for compatibility with these signal characteristics. Switching characteristics tell you what the processor will do in a given circumstance. You can also use switching characteristics to ensure that any timing requirement of a device connected to the processor (such as memory) is satisfied.

Timing requirements apply to signals that are controlled by circuitry external to the processor, such as the data input for a read operation. Timing requirements guarantee that the processor operates correctly with other devices.

Frequency Dependency For Timing Specifications

t_{CK} is defined as $0.5 t_{CKI}$. The ADSP-21mod980N uses an input clock with a frequency equal to half the instruction rate. For example, a 40 MHz input clock (which is equivalent to 25 ns) yields a 12.5 ns processor cycle (equivalent to 80 MHz). t_{CK} values within the range of $0.5 t_{CKI}$ period should be substituted for all relevant timing parameters to obtain the specification value.

Example: $t_{CKH} = 0.5 t_{CK} - 2 \text{ ns} = 0.5 (12.5 \text{ ns}) - 2 \text{ ns} = 4.25 \text{ ns}$

Output Drive Currents

Figure 14 shows typical I-V characteristics for the output drivers on the ADSP-21mod980N. The curves represent the current drive capability of the output drivers as a function of output voltage

Capacitive Loading

Figure 16 and Figure 17 show the capacitive loading characteristics of the ADSP-21mod980N.

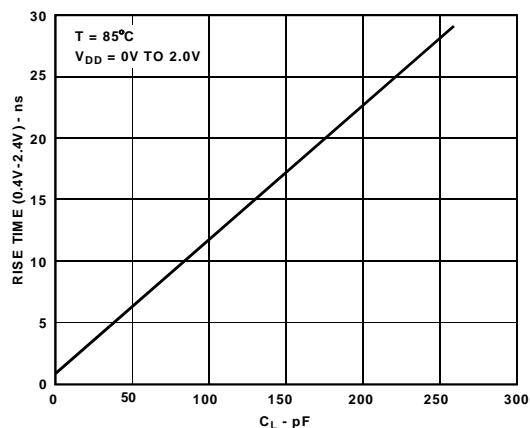

Figure 17. Typical Output Rise Time vs. Load Capacitance (at Maximum Ambient Operating Temperature)

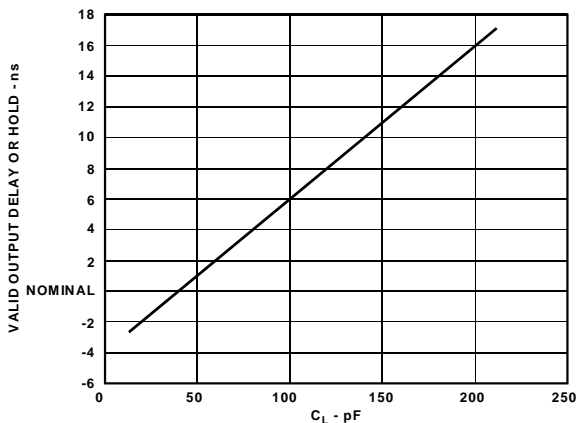

Figure 18. Typical Output Valid Delay or Hold vs. Load Capacitance, CL (at Maximum Ambient Operating Temperature)

PRELIMINARY TECHNICAL DATA

For current information contact Analog Devices at (800) ANALOGD

ADSP-21mod980N

Clock and Reset Signals

Table 9. Clock and Reset Signals

Parameter	Description	Min.	Max	Unit
Clock signals (Timing Requirements):				
t_{CKI}	CLKIN Period	25.0	40.0	ns
t_{CKIL}	CLKIN Width Low	8		ns
t_{CKIH}	CLKIN Width High	8		ns
t_{CKRISE}	CLKIN rise time ¹		4	ns
t_{CKFALL}	CLKIN fall time		4	ns
Clock signals (Switching Characteristics) ² :				
t_{CKL}	CLKOUT Width Low	$0.5t_{CK} - 3$		ns
t_{CKH}	CLKOUT Width High	$0.5t_{CK} - 3$		ns
t_{CKOH}	CLKIN High to CLKOUT High	0	8	ns
Control Signals (Timing Requirements):				
t_{RSP}	$\overline{\text{RESET}}$ Width Low	$5t_{CK}^3$		ns
t_{MS}	Mode Setup Before $\overline{\text{RESET}}$ High	4		ns
t_{MH}	Mode Hold After $\overline{\text{RESET}}$ High	5		ns

¹ t_{CKRISE} and t_{CKFALL} are specified between the 10% and 90% points on the signal edge.

² If it is not needed by the application, CLKOUT should be disabled to reduce noise (DM(0x3FF3) bit 14).

³ Applies after power-up sequence is complete. Internal phase lock loop requires no more than 2000 CLKIN cycles assuming stable CLKIN (not including crystal oscillator start-up time).

PRELIMINARY TECHNICAL DATA

ADSP-21mod980N For current information contact Analog Devices at (800) ANALOGD

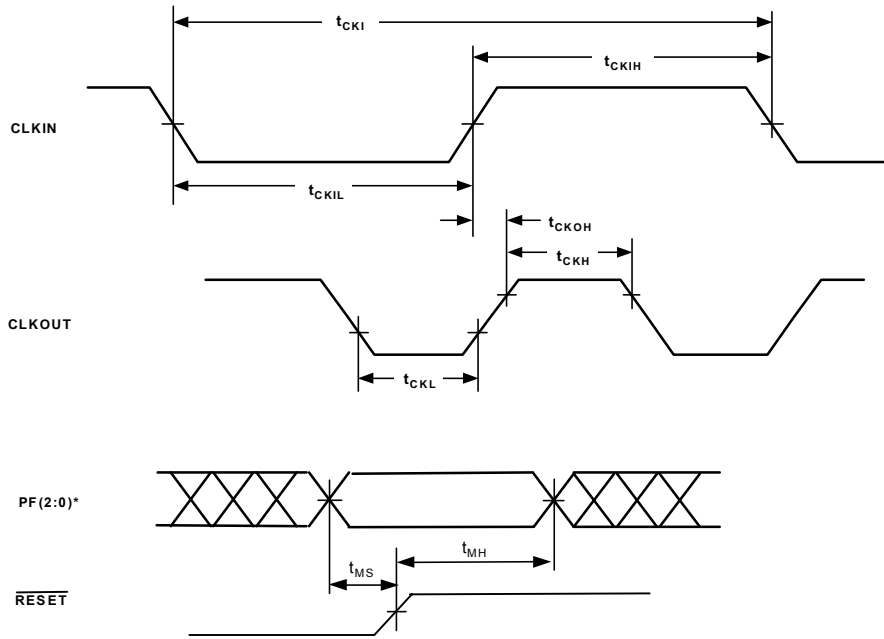

*PF2 is Mode C, PF1 is Mode B, PF0 is Mode A

Figure 19. Clock and Reset Signals

PRELIMINARY TECHNICAL DATA

For current information contact Analog Devices at (800) ANALOGD

ADSP-21mod980N

Interrupts and Flags

Table 10. Interrupts and Flags

Parameter	Description	Min.	Max	Unit
Timing Requirements:				
t_{IFS}	\overline{IRQx} , FI, or PFx Setup before CLKOUT Low ^{1, 2, 3, 4}	$0.25t_{CK} + 10$		ns
t_{IFH}	\overline{IRQx} , FI, or PFx Hold after CLKOUT High ^{1, 2, 3, 4}	$0.25t_{CK}$		ns
Switching Characteristics:				
t_{FOH}	Flag Output Hold after CLKOUT Low ⁵	$0.5t_{CK} - 5$		ns
t_{FOD}	Flag Output Delay from CLKOUT Low ⁵		$0.5t_{CK} + 4$	ns

¹ If \overline{IRQx} and FI inputs meet t_{IFS} and t_{IFH} setup/hold requirements, they will be recognized during the current clock cycle; otherwise the signals will be recognized on the following cycle. (Refer to Interrupt Controller Operation in the Program Control chapter of the *ADSP-2100 Family User's Manual* for further information on interrupt servicing.)

² Edge-sensitive interrupts require pulse widths greater than 10 ns; level-sensitive interrupts must be held low until serviced.

³ $\overline{IRQx} = \overline{IRQ0}, \overline{IRQ1}, \overline{IRQ2}, \overline{IRQL0}, \overline{IRQL1}, \overline{IRQE}$.

⁴ PFx = PF0, PF1, PF2, PF4, PF5, PF6, PF7.

⁵ Flag Outputs = PFx, Flag_out⁴.

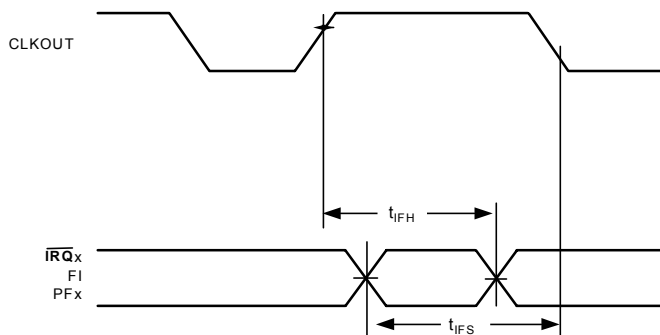

Figure 20. Interrupts and Flags

PRELIMINARY TECHNICAL DATA

ADSP-21mod980N

For current information contact Analog Devices at (800) ANALOGD

Serial Ports

Table 11. Serial Ports

Parameter	Description	Min.	Max	Unit
Timing Requirements:				
t_{SCK}	SCLK Period	30		ns
t_{SCS}	DR/TFS/RFS Setup before SCLK Low	4		ns
t_{SCH}	DR/TFS/RFS Hold after SCLK Low	7		ns
t_{SCP}	SCLKIN Width	12		ns
Switching Characteristics:				
t_{CC}	CLKOUT High to SCLKOUT	$0.25t_{CK}$	$0.25t_{CK} + 6$	ns
t_{SCDE}	SCLK High to DT Enable	0		ns
t_{SCDV}	SCLK High to DT Valid		12	ns
t_{RH}	TFS/RFSOUT Hold after SCLK High	0		ns
t_{RD}	TFS/RFSOUT Delay from SCLK High		12	ns
t_{SCDH}	DT Hold after SCLK High	0		ns
t_{TDE}	TFS (Alt) to DT Enable	0		ns
t_{TDV}	TFS (Alt) to DT Valid		12	ns
t_{SCDD}	SCLK High to DT Disable		12	ns
t_{RDV}	RFS (Multichannel, Frame Delay Zero to DT Valid		12	ns

PRELIMINARY TECHNICAL DATA

For current information contact Analog Devices at (800) ANALOGD

ADSP-21mod980N

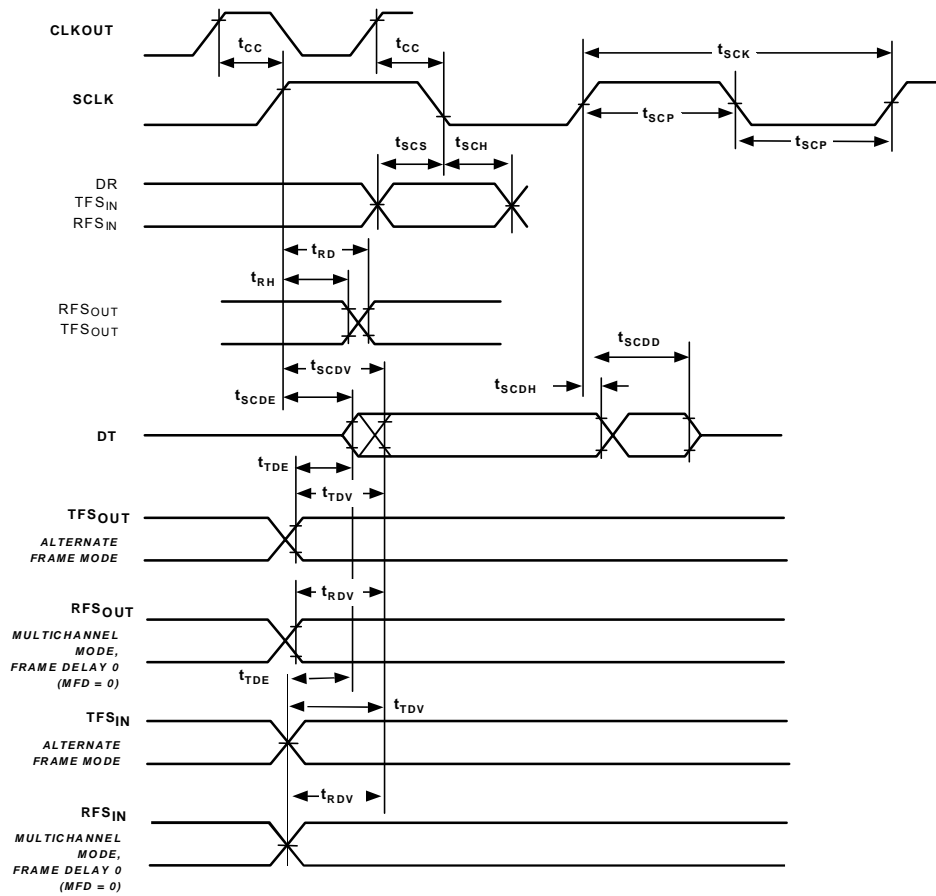

Figure 21. Serial Ports

PRELIMINARY TECHNICAL DATA

ADSP-21mod980N For current information contact Analog Devices at (800) ANALOGD

IDMA Address Latch

Table 12. IDMA Address Latch

Parameter	Description	Min.	Max	Unit
Timing Requirements:				
t_{IALP}	Duration of Address Latch ^{1, 2, 3}	10		ns
t_{IASU}	IAD[15:0] Address Setup before Address Latch End ^{2, 3}	5		ns
t_{IAH}	IAD[15:0] Address Hold after Address Latch End ^{2, 3}	3		ns
t_{IKA}	\overline{IACK} Low before Start of Address Latch ^{2, 3, 4}	0		ns
t_{IALS}	Start of Write or Read after Address Latch End ^{2, 3, 4}	3		ns
t_{IALD}	Address Latch Start after Address Latch End ^{1, 2, 3}	2		ns

- ¹ Start of Address Latch = \overline{IS} Low and IAL High.
- ² End of Address Latch = \overline{IS} High or IAL Low.
- ³ For IDMA, please refer to the *ADSP-2100 Family User's Manual*.
- ⁴ Start of Write or Read = \overline{IS} Low and \overline{IWR} Low or \overline{IRD} Low.

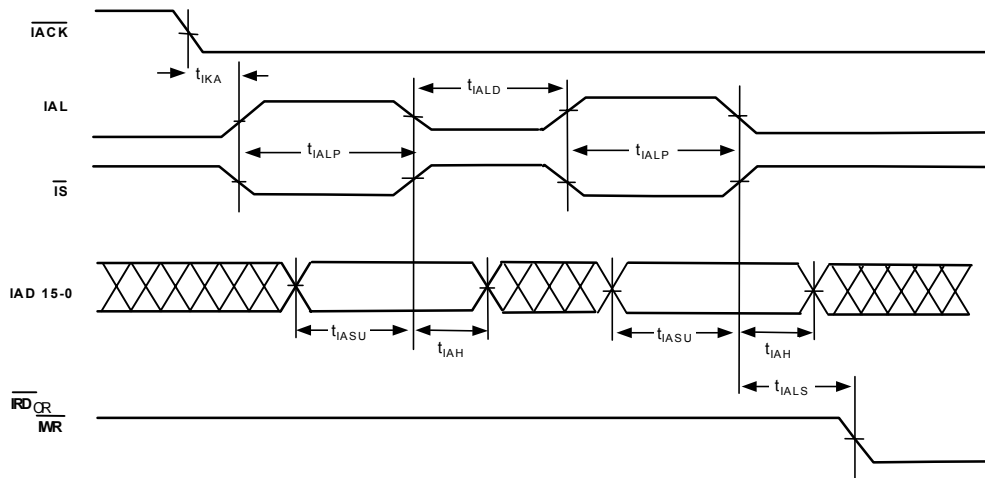

Figure 22. IDMA Address Latch

PRELIMINARY TECHNICAL DATA

For current information contact Analog Devices at (800) ANALOGD

ADSP-21mod980N

IDMA Write, Short Write Cycle

Table 13. IDMA Write, Short Write Cycle

Parameter	Description	Min.	Max	Unit
Timing Requirements:				
t_{IKW}	\overline{IACK} Low before Start of Write ^{1, 2}	0		ns
t_{IWP}	Duration of Write ^{1, 2, 3}	10		ns
t_{IDSU}	IAD[15:0] Data Setup before End of Write ^{2, 3, 4, 5}	3		ns
t_{IDH}	IAD[15:0] Data Hold after End of Write ^{2, 3, 4, 5}	2		ns
Switching Characteristics:				
t_{IKHW}	Start of Write to \overline{IACK} High		10	ns

¹ Start of Write = \overline{IS} Low and \overline{IWR} Low.

² For IDMA, please refer to the *ADSP-2100 Family User's Manual*.

³ End of Write = \overline{IS} High or \overline{IWR} High.

⁴ If Write Pulse ends before \overline{IACK} Low, use specifications t_{IDSU} , t_{IDH} .

⁵ If Write Pulse ends after \overline{IACK} Low, use specifications t_{IKSU} , t_{IKH} .

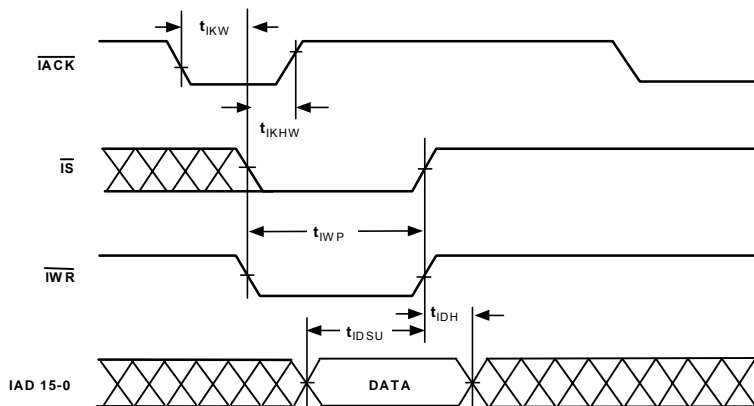

Figure 23. IDMA Write, Short Write Cycle

PRELIMINARY TECHNICAL DATA

ADSP-21mod980N For current information contact Analog Devices at (800) ANALOGD

IDMA Write, Long Write Cycle

Table 14. IDMA Write, Long Write Cycle

Parameter	Description	Min.	Max	Unit
Timing Requirements				
t_{IKW}	\overline{IACK} Low before Start of Write ¹	0		ns
t_{IKSU}	IAD[15:0] Data Setup before End of Write ^{2, 3, 4}	$0.5t_{CK} + 5$		ns
t_{IKH}	IAD[15:0] Data Hold after End of Write ^{2, 3, 4}	0		ns
Switching Characteristics:				
t_{IKLW}	Start of Write to \overline{IACK} Low ⁴	$1.5t_{CK}$		ns
t_{IKHW}	Start of Write to \overline{IACK} High		10	ns

¹ Start of Write = \overline{IS} Low and \overline{IWR} Low.

² If Write Pulse ends before \overline{IACK} Low, use specifications t_{IDSU} , t_{IDH} .

³ If Write Pulse ends after \overline{IACK} Low, use specifications t_{IKSU} , t_{IKH} .

⁴ This is the earliest time for \overline{IACK} Low from Start of Write. For IDMA Write cycle relationships, please refer to the *ADSP-2100 Family User's Manual*.

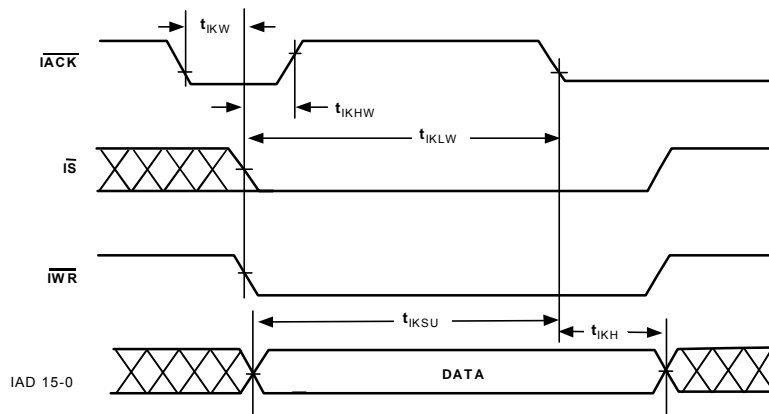

Figure 24. IDMA Write, Long Write Cycle

PRELIMINARY TECHNICAL DATA

For current information contact Analog Devices at (800) ANALOGD

ADSP-21mod980N

IDMA Read, Long Read Cycle

Table 15. IDMA Read, Long Read Cycle

Parameter	Description	Min.	Max	Unit
Timing Requirements:				
t_{IKR}	\overline{IACK} Low before Start of Read ^{1, 2}	0		ns
t_{IRK}	End of Read after \overline{IACK} Low ^{2, 3}	2		ns
Switching Characteristics:				
t_{IKHR}	\overline{IACK} High after Start of Read ^{1, 2}		10	ns
t_{IKDS}	IAD[15:0] Data Setup before \overline{IACK} Low ²	$0.5t_{CK} - 2$		ns
t_{IKDH}	IAD[15:0] Data Hold after End of Read ^{2, 3}	0		ns
t_{IKDD}	IAD[15:0] Data Disabled after End of Read ^{2, 3}		10	ns
t_{IRDE}	IAD[15:0] Previous Data Enabled after Start of Read ²	0		ns
t_{IRDV}	IAD[15:0] Previous Data Valid after Start of Read ²		10	ns
t_{IRDH}^1	IAD[15:0] Previous Data Hold after Start of Read (DM/PM1) ^{2, 4}	$2t_{CK} - 5$		ns
t_{IRDH}^2	IAD[15:0] Previous Data Hold after Start of Read (PM2) ^{2, 5}	$t_{CK} - 5$		ns

¹ Start of Read = \overline{IS} Low and \overline{IRD} Low.

² For IDMA, please refer to the *ADSP-2100 Family User's Manual*.

³ End of Read = \overline{IS} High or \overline{IRD} High.

⁴ DM read or first half of PM read.

⁵ Second half of PM read.

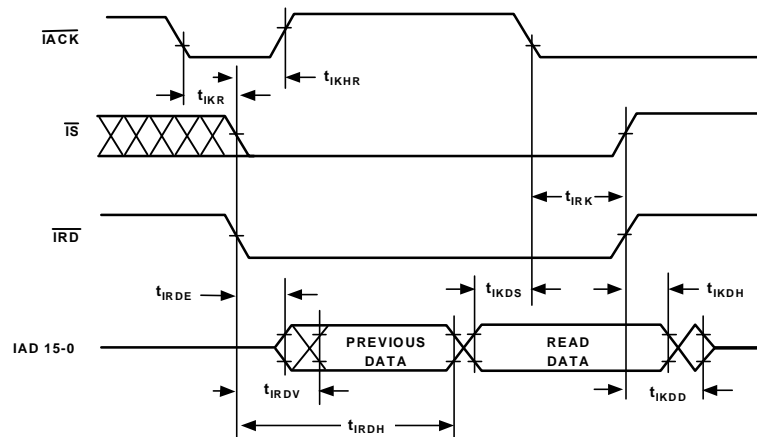

Figure 25. IDMA Read, Long Read Cycle

PRELIMINARY TECHNICAL DATA

ADSP-21mod980N For current information contact Analog Devices at (800) ANALOGB

IDMA Read, Short Read Cycle

Table 16. IDMA Read, Short Read Cycle¹

Parameter	Description	Min.	Max	Unit
Timing Requirements:				
t_{IKR}	\overline{IACK} Low before Start of Read ²	0		ns
t_{IRP}	Duration of Read	10		ns
Switching Characteristics:				
t_{IKHR}	\overline{IACK} High after Start of Read ^{2,3}		10	ns
t_{IKDH}	IAD[15:0] Data Hold after End of Read ^{3,4}	0		ns
t_{IKDD}	IAD[15:0] Data Disabled after End of Read ^{3,4}		10	ns
t_{IRDE}	IAD[15:0] Previous Data Enabled after Start of Read ³	0		ns
t_{IRDV}	IAD[15:0] Previous Data Valid after Start of Read ³		10	ns
t_{IRDH}^1	IAD[15:0] Previous Data Hold after Start of Read (DM/PM1) ^{3,5}	$2t_{CK} - 5$		ns
t_{IRDH}^2	IAD[15:0] Previous Data Hold after Start of Read (PM2) ^{3,6}	$t_{CK} - 5$		ns

¹ Timing applies to ADSP-21mod980N when Short Read Only mode is disabled. See [Table on page 35](#).

² Start of Read = \overline{IS} Low and \overline{IRD} Low.

³ For IDMA, please refer to the *ADSP-2100 Family User's Manual*.

⁴ End of Read = \overline{IS} High or \overline{IRD} High.

⁵ DM read or first half of PM read.

⁶ Second half of PM read.

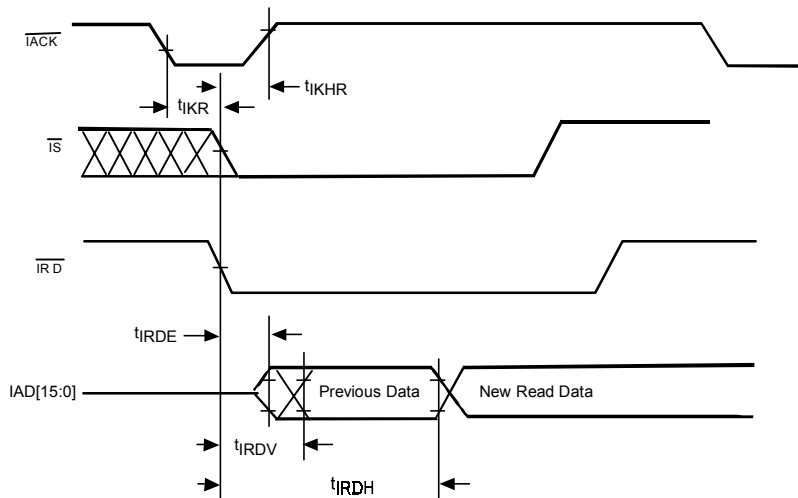

Figure 26. IDMA Read, Short Read Cycle

PRELIMINARY TECHNICAL DATA

For current information contact Analog Devices at (800) ANALOGD

ADSP-21mod980N

IDMA Read - Short Read Cycle in Short Read Only Mode

Table 17. IDMA Read - Short Read Cycle in Short Read Only Mode¹

Parameter	Description	Min.	Max	Unit
Timing Requirements:				
t_{IKR}	\overline{IACK} Low before Start of Read ^{2, 4}	0		ns
t_{IRP}	Duration of Read after \overline{IACK} Low ^{3, 4}	10		ns
Switching Characteristics:				
t_{IKHR}	\overline{IACK} High after Start of Read ^{2, 4}		10	ns
t_{IKDH}	IAD[15:0] Previous Data Hold after End of Read ^{3, 4}	0		ns
t_{IKDD}	IAD[15:0] Previous Data Disabled after End of Read ^{3, 4}		10	ns
t_{IRDE}	IAD[15:0] Previous Data Enabled after Start of Read ⁴	0		ns
t_{IRDV}	IAD[15:0] Previous Data Valid after Start of Read ⁴		10	ns

¹ Short Read Only is enabled by setting Bit 14 of the IDMA Overlay Register to 1 (0x3FE7). Short Read Only can be enabled by the processor core writing to the register or by an external host writing to the register. Disabled by default.

² Start of Read = \overline{IS} Low and \overline{IRD} Low. Previous data remains until end of read.

³ End of Read = \overline{IS} High or \overline{IRD} High.

⁴ For IDMA, please refer to the *ADSP-2100 Family User's Manual*.

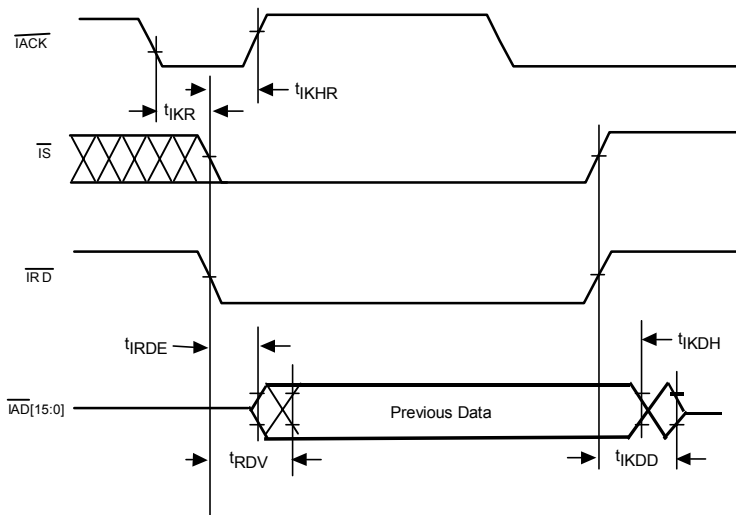

Figure 27. IDMA Read, Short Read Only Mode

ADSP-21mod980N

For current information contact Analog Devices at (800) ANALOGD

**352-BALL PBGA
PACKAGE PINOUT**

A physical layout of all signals is shown in the following tables. Figure on page 40 shows the signals on the left side of the device when viewed from the top. Figure on page 41 shows the signals on the right side of the device when viewed from the top. The pin number for each signal is listed in Table on page 36.

Table 18. Pinout by Signal Name

Signal Name	Pin
A0	A2
$\overline{\text{BG}}_1$	F3
$\overline{\text{BG}}_2$	D14
$\overline{\text{BG}}_3$	F25
$\overline{\text{BG}}_4$	AC5
$\overline{\text{BG}}_5$	R25
$\overline{\text{BG}}_6$	R4
$\overline{\text{BG}}_7$	AD15
$\overline{\text{BG}}_8$	AD25
$\overline{\text{BR}}_1$	G4
$\overline{\text{BR}}_2$	B13
$\overline{\text{BR}}_3$	G25
$\overline{\text{BR}}_4$	AC9
$\overline{\text{BR}}_5$	N24
$\overline{\text{BR}}_6$	U4
$\overline{\text{BR}}_7$	AE15
$\overline{\text{BR}}_8$	AE26
CLKIN	E3
CLKOUT_1	G1
CLKOUT_2	A10

Table 18. Pinout by Signal Name (Continued)

Signal Name	Pin
CLKOUT_3	C20
CLKOUT_4	AC1
CLKOUT_5	L24
CLKOUT_6	P4
CLKOUT_7	AD10
CLKOUT_8	AF15
D08	F23
D09	E25
D10	E24
D11	D26
D12	D25
D13	D24
D14	C26
D15	C25
D16	B26
D17	B24
D18	A25
D19	B23
D20	C23
D21	A24
D22	A23
D23	A22
DR0A	E1
DR0B	AF22
DR1	AE7
DT0A	P2
DT0B	AF20
DT1_1	P3
DT1_2	A12
DT1_3	D21

Table 18. Pinout by Signal Name (Continued)

Signal Name	Pin
DT1_4	AF2
DT1_5	T25
DT1_6	U3
DT1_7	AD13
DT1_8	AE20
$\overline{\text{EBG}}$	F26
$\overline{\text{EBR}}$	G26
ECLK	J23
EE_1	M4
EE_2	C13
EE_3	G23
EE_4	AE9
EE_5	T26
EE_6	Y2
EE_7	AC13
EE_8	AE22
$\overline{\text{EINT}}$	J26
ELIN	J25
ELOUT	J24
$\overline{\text{EMS}}$	E23
$\overline{\text{ERESET}}$	E26
GND	D19
GND	D20
GND	D23
GND	F1
GND	F2
GND	F4
GND	G2
GND	G3
GND	H1

Table 18. Pinout by Signal Name (Continued)

Signal Name	Pin
GND	H2
GND	H3
GND	H4
GND	H23
GND	H24
GND	H25
GND	H26
GND	N1
GND	N2
GND	N3
GND	N4
GND	R23
GND	R24
GND	T3
GND	T24
GND	U1
GND	U2
GND	U23
GND	U24
GND	U25
GND	U26
GND	W1
GND	W2
GND	W3
GND	W4
GND	AF1
GND	AF4
GND	AF8
GND	AF10
GND	AF12

PRELIMINARY TECHNICAL DATA

For current information contact Analog Devices at (800) ANALOGD

ADSP-21mod980N

Table 18. Pinout by Signal Name (Continued)

Signal Name	Pin
GND	AF16
GND	AF17
GND	AF21
GND	AF23
GND	AF26
GND	B2
GND	B5
GND	B11
GND	B12
GND	B16
GND	B19
GND	B21
GND	B25
GND	C3
GND	C5
GND	C11
GND	C16
GND	C19
GND	C21
GND	C24
GND	D4
GND	D5
GND	D11
GND	D16
GND	AC12
GND	AC17
GND	AC21
GND	AC23
GND	AD2
GND	AD3

Table 18. Pinout by Signal Name (Continued)

Signal Name	Pin
GND	AD4
GND	AD5
GND	AD7
GND	AD8
GND	AD11
GND	AD12
GND	AD16
GND	AD17
GND	AD21
GND	AD22
GND	AD23
GND	AD24
GND	AE1
GND	AE2
GND	AE4
GND	AE8
GND	AE10
GND	AE12
GND	AE16
GND	AE17
GND	AE21
GND	AE23
GND	AE25
GND	A1
GND	A5
GND	A11
GND	A16
GND	A19
GND	A20
GND	A21

Table 18. Pinout by Signal Name (Continued)

Signal Name	Pin
GND	A26
GND	AA23
GND	AA24
GND	AA25
GND	AA26
GND	AC4
GND	AC6
GND	AC8
GND	AC10
GND	W23
$\overline{\text{IACK_A}}$	T4
$\overline{\text{IACK_B}}$	AC26
IAD0_A	B4
IAD0_B	V26
IAD1_A	B1
IAD1_B	V23
IAD10_A	AA2
IAD10_B	L26
IAD11_A	V3
IAD11_B	L23
IAD12_A	AA4
IAD12_B	M25
IAD13_A	E2
IAD13_B	AD26
IAD14_A	D1
IAD14_B	AC24
IAD15_A	E4
IAD15_B	AC25
IAD2_A	C2
IAD2_B	V24

Table 18. Pinout by Signal Name (Continued)

Signal Name	Pin
IAD3_A	D3
IAD3_B	W24
IAD4_A	C1
IAD4_B	W25
IAD5_A	D2
IAD5_B	W26
IAD6_A	V4
IAD6_B	M26
IAD7_A	Y4
IAD7_B	N26
IAD8_A	AD6
IAD8_B	M23
IAD9_A	Y3
IAD9_B	M24
IAL_A	C8
IAL_B	Y25
$\overline{\text{IRD_A}}$	C4
$\overline{\text{IRD_B}}$	Y24
$\overline{\text{IS_1}}$	D6
$\overline{\text{IS_2}}$	A14
$\overline{\text{IS_3}}$	F24
$\overline{\text{IS_4}}$	AA3
$\overline{\text{IS_5}}$	V25
$\overline{\text{IS_6}}$	AC7
$\overline{\text{IS_7}}$	AC16
$\overline{\text{IS_8}}$	Y26
$\overline{\text{IWR_A}}$	D8
$\overline{\text{IWR_B}}$	Y23
PF0	A6
PF1	B6

PRELIMINARY TECHNICAL DATA

ADSP-21mod980N

For current information contact Analog Devices at (800) ANALOGD

Table 18. Pinout by Signal Name (Continued)

Signal Name	Pin
PF2	C6
PF4_1	M1
PF4_2	C10
PF4_3	D18
PF4_4	AC2
PF4_5	L25
PF4_6	T1
PF4_7	AF7
PF4_8	AD18
PF5_1	M2
PF5_2	D10
PF5_3	C18
PF5_4	AC3
PF5_5	G24
PF5_6	V1
PF5_7	AE11
PF5_8	AE18
PF6_1	M3
PF6_2	B10
PF6_3	B18
PF6_4	AD1
PF6_5	R26
PF6_6	T2
PF6_7	AD9
PF6_8	AC18
PF7_1	J4
PF7_2	D12
PF7_3	A18
PF7_4	AE3
PF7_5	N25

Table 18. Pinout by Signal Name (Continued)

Signal Name	Pin
PF7_6	V2
PF7_7	AF9
PF7_8	AF18
$\overline{\text{RESET}}_1$	J1
$\overline{\text{RESET}}_2$	D13
$\overline{\text{RESET}}_3$	C22
$\overline{\text{RESET}}_4$	AF6
$\overline{\text{RESET}}_5$	T23
$\overline{\text{RESET}}_6$	AA1
$\overline{\text{RESET}}_7$	AC11
$\overline{\text{RESET}}_8$	AC22
RFS0A	J3
RFS0B	AD20
RFS1	AE6
SCLK0A	P1
SCLK0B	AE24
SCLK1	AF5
TFS0_1	J2
TFS0_2	C12
TFS0_3	B20
TFS0_4	AE5
TFS0_5	N23
TFS0_6	Y1
TFS0_7	AF11
TFS0_8	AC20
TFS1	AF3
VDDEXT	B22
VDDEXT	C7
VDDEXT	C9
VDDEXT	C14

Table 18. Pinout by Signal Name (Continued)

Signal Name	Pin
VDDEXT	C15
VDDEXT	C17
VDDEXT	D7
VDDEXT	D9
VDDEXT	D15
VDDEXT	D17
VDDEXT	D22
VDDEXT	K1
VDDEXT	K2
VDDEXT	K3
VDDEXT	K4
VDDEXT	K23
VDDEXT	K24
VDDEXT	K25
VDDEXT	K26
VDDEXT	L1
VDDEXT	L2
VDDEXT	L3
VDDEXT	L4
VDDEXT	A7
VDDEXT	A8
VDDEXT	A9
VDDEXT	A13
VDDEXT	A15
VDDEXT	A17
VDDEXT	AC14
VDDEXT	AC15
VDDEXT	AC19
VDDEXT	AD14
VDDEXT	AD19

Table 18. Pinout by Signal Name (Continued)

Signal Name	Pin
VDDEXT	AE14
VDDEXT	AE19
VDDEXT	AF14
VDDEXT	AF19
VDDEXT	B7
VDDEXT	B8
VDDEXT	B9
VDDEXT	B14
VDDEXT	B15
VDDEXT	B17
VDDINT	A3
VDDINT	A4
VDDINT	AB1
VDDINT	AB2
VDDINT	AB3
VDDINT	AB4
VDDINT	AB23
VDDINT	AB24
VDDINT	AB25
VDDINT	AB26
VDDINT	AE13
VDDINT	AF13
VDDINT	AF24
VDDINT	AF25
VDDINT	B3
VDDINT	P23
VDDINT	P24
VDDINT	P25
VDDINT	P26

PRELIMINARY TECHNICAL DATA

For current information contact Analog Devices at (800) ANALOGD

ADSP-21mod980N

**Table 18. Pinout by
Signal Name (Continued)**

Signal Name	Pin
VDDINT	R1
VDDINT	R2
VDDINT	R3

PRELIMINARY TECHNICAL DATA

ADSP-21mod980N For current information contact Analog Devices at (800) ANALOGD

Signals by Pin Location—Top View, Left to Right

	1	2	3	4	5	6	7	8	9	10	11	12	13
A	GND	A0	VDDINT	VDDINT	GND	PF0	VDDEXT	VDDEXT	VDDEXT	CLKOUT_2	GND	DT1_2	VDDEXT
B	IAD1_A	GND	VDDINT	IAD0_A	GND	PF1	VDDEXT	VDDEXT	VDDEXT	PF6_2	GND	GND	BR_2
C	IAD4_A	IAD2_A	GND	IRD_A	GND	PF2	VDDEXT	IAL_A	VDDEXT	PF4_2	GND	TFS0_2	EE_2
D	IAD14_A	IAD6_A	IAD3_A	GND	GND	IS_1	VDDEXT	IWR_A	VDDEXT	PF5_2	GND	PF7_2	RESET_2
E	DR0A	IAD13_A	CLKIN	IAD15_A									
F	GND	GND	BG_1	GND									
G	CLKOUT_1	GND	GND	BR_1									
H	GND	GND	GND	GND									
J	RESET_1	TFS0_1	RFS0A	PF7_1									
K	VDDEXT	VDDEXT	VDDEXT	VDDEXT									
L	VDDEXT	VDDEXT	VDDEXT	VDDEXT									
M	PF4_1	PF5_1	PF6_1	EE_1									
N	GND	GND	GND	GND									
P	SCLK0A	DT0A	DT1_1	CLKOUT_6									
R	VDDINT	VDDINT	VDDINT	BG_6									
T	PF4_6	PF6_6	GND	IACK_A									
U	GND	GND	DT1_6	BR_6									
V	PF5_6	PF7_6	IAD11_A	IAD6_A									
W	GND	GND	GND	GND									
Y	TFS0_6	EE_6	IAD9_A	IAD7_A									
AA	RESET_6	IAD10_A	IS_4	IAD12_A									
AB	VDDINT	VDDINT	VDDINT	VDDINT									
AC	CLKOUT_4	PF4_4	PF5_4	GND	BG_4	GND	IS_6	GND	BR_4	GND	RESET_7	GND	EE_7
AD	PF6_4	GND	GND	GND	GND	IAD8_A	GND	GND	PF6_7	CLKOUT_7	GND	GND	DT1_7
AE	GND	GND	PF7_4	GND	TFS0_4	RFS1	DR1	GND	EE_4	GND	PF5_7	GND	VDDINT
AF	GND	DT1_4	TFS1	GND	SCLK1	RESET_4	PF4_7	GND	PF7_7	GND	TFS0_7	GND	VDDINT
	1	2	3	4	5	6	7	8	9	10	11	12	13

PRELIMINARY TECHNICAL DATA

For current information contact Analog Devices at (800) ANALOGD

ADSP-21mod980N

OUTLINE DIMENSIONS – 352 PLASTIC BALL GRID ARRAY

Signals by Pin Location—Top View, Left to Right (Continued)

14	15	16	17	18	19	20	21	22	23	24	25	26	
IS_2	VDDEXT	GND	VDDEXT	PF7_3	GND	GND	GND	D23	D22	D21	D18	GND	A
VDDEXT	VDDEXT	GND	VDDEXT	PF6_3	GND	TRS0_3	GND	VDDEXT	D19	D17	GND	D16	B
VDDEXT	VDDEXT	GND	VDDEXT	PF5_3	GND	CLKOUT_3	GND	RESET_3	D20	GND	D15	D14	C
BG_2	VDDEXT	GND	VDDEXT	PF4_3	GND	GND	DT1_3	VDDEXT	GND	D13	D12	D11	D
									EMS	D10	D09	ERESET	E
									D08	IS_3	BG_3	EBG	F
									EE_3	PF5_5	BR_3	EBR	G
									GND	GND	GND	GND	H
									ECLK	ELOUT	ELIN	EINT	J
									VDDEXT	VDDEXT	VDDEXT	VDDEXT	K
									IAD11_B	CLKOUT_5	PF4_5	IAD10_B	L
									IAD8_B	IAD9_B	IAD12_B	IAD6_B	M
									TFS0_5	BR_5	PF7_5	IAD7_B	N
									VDDINT	VDDINT	VDDINT	VDDINT	P
									GND	GND	BG_5	PF6_5	R
									RESET_5	GND	DT1_5	EE_5	T
									GND	GND	GND	GND	U
									IAD1_B	IAD2_B	IS_5	IAD0_B	V
									GND	IAD3_B	IAD4_B	IAD5_B	W
									IWR_B	IRD_B	IAL_B	IS_8	Y
									GND	GND	GND	GND	AA
									VDDINT	VDDINT	VDDINT	VDDINT	AB
VDDEXT	VDDEXT	IS_7	GND	PF6_8	VDDEXT	TFS0_8	GND	RESET_8	GND	IAD14_B	IAD15_B	IACK_B	AC
VDDEXT	BG_7	GND	GND	PF4_8	VDDEXT	RFS0B	GND	GND	GND	GND	BG_8	IAD13_B	AD
VDDEXT	BR_7	GND	GND	PF5_8	VDDEXT	DT1_8	GND	EE_8	GND	SCLK0B	GND	BR_8	AE
VDDEXT	CLKOUT_8	GND	GND	PF7_8	VDDEXT	DT0B	GND	DR0B	GND	VDDINT	VDDINT	GND	AF
14	15	16	17	18	19	20	21	22	23	24	25	26	

PRELIMINARY TECHNICAL DATA

ADSP-21mod980N For current information contact Analog Devices at (800) ANALOGD

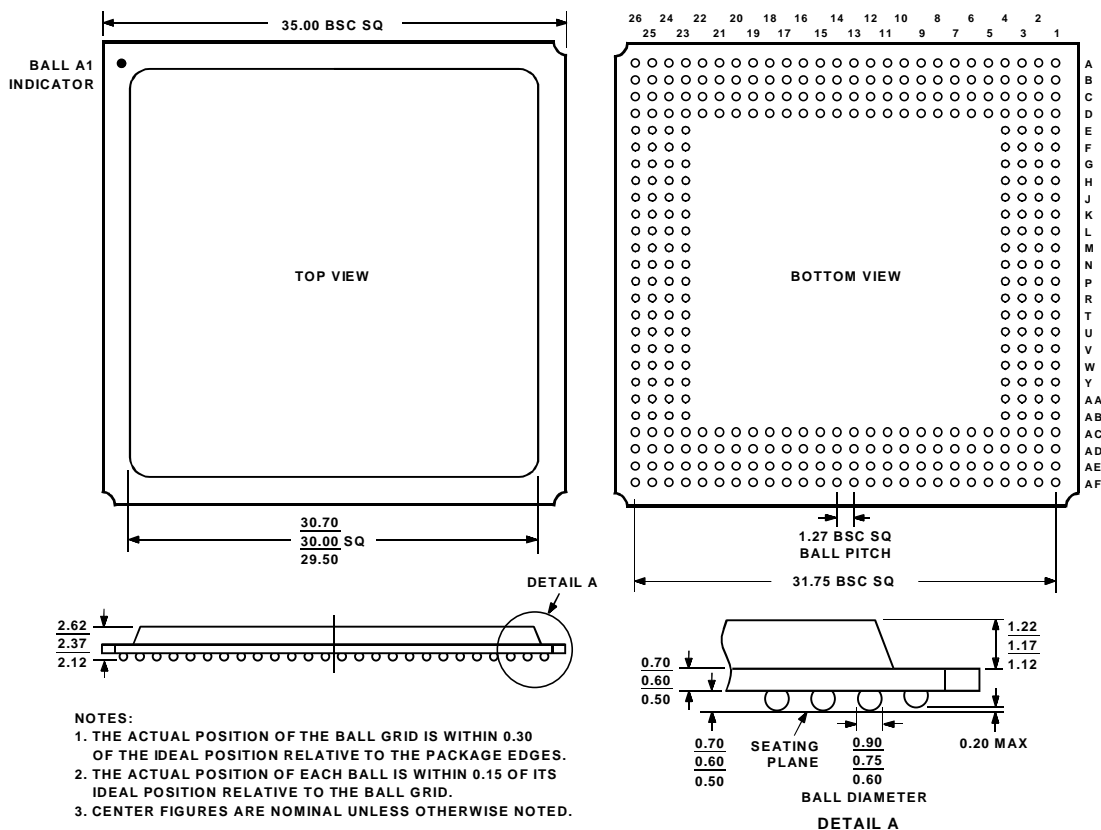

Figure 28. 352-Lead metric Plastic Ball Grid Array (PBGA) (B-352)

ORDERING GUIDE

A complete modem requires the device listed in [Table 19](#) plus a software solution as described in **MODEM SOFTWARE** on page 2.

Table 19. Ordering Guide

Part Number	Ambient Temperature Range	Instruction Rate	Package Description	Package Option
ADSP-21mod980N-000	0°C to +70°C	80 MHz	352-Ball PBGA	B-352

This datasheet has been downloaded from:

www.DatasheetCatalog.com

Datasheets for electronic components.



LittleDiode supplies new, hard to find or obsolete electronic components and semiconductors all over the world.

With over two million different components listed you are sure to find the part you need.

Feel free to visit us today at our online store:

LittleDiode.com

Looking forward to providing you with the best possible service.