

ADSP-21msp58/59

FEATURES

38 ns Instruction Cycle Time (26 MIPS) from 13.00 MHz Crystal

ADSP-2100 Family Code and Function Compatible with New Instruction Set Enhanced for Bit Manipulation Instructions, Multiplication Instructions, Biased Rounding, and Global Interrupt Masking

2K × 24 Words of On-Chip Program Memory RAM

2K × 16 Words of On-Chip Data Memory RAM

4K × 24 Words of On-Chip Program Memory ROM (ADSP-21msp59 Only)

8-Bit Parallel Host Interface Port

Analog Interface Provides:

16-Bit Sigma-Delta ADC and DAC

Programmable Gain Stages

On-Chip Anti-Aliasing & Anti-Imaging Filters

8 kHz Sampling Frequency

65 dB ADC, SNR and THD

72 dB DAC, SNR and THD

425 mW Typical Power Dissipation @ 5.0 V @ 38 ns

<1 mW Powerdown Mode with 100 Cycle Recovery

Dual Purpose Program Memory for Both Instruction and Data Storage

Independent ALU, Multiplier/Accumulator, and Barrel Shifter Computational Units

Two Independent Data Address Generators

Powerful Program Sequencer Provides:

Zero Overhead Looping

Conditional Instruction Execution

Two Double-Buffered Serial Ports with Companding

Hardware, One Serial Port (SPORT0) has Automatic Data Buffering

Programmable 16-Bit Interval Timer with Prescaler

Programmable Wait State Generation

Automatic Booting of Internal Program Memory from

Byte-Wide External Memory, e.g., EPROM, or Through Host Interface Port

Stand-Alone ROM Execution (ADSP-21msp59 Only)

Single-Cycle Instruction Execution

Single-Cycle Context Switch

Multifunction Instructions

Three Edge- or Level-Sensitive External Interrupts

Low Power Dissipation in Standby Mode

100-Lead TQFP

FUNCTIONAL BLOCK DIAGRAM

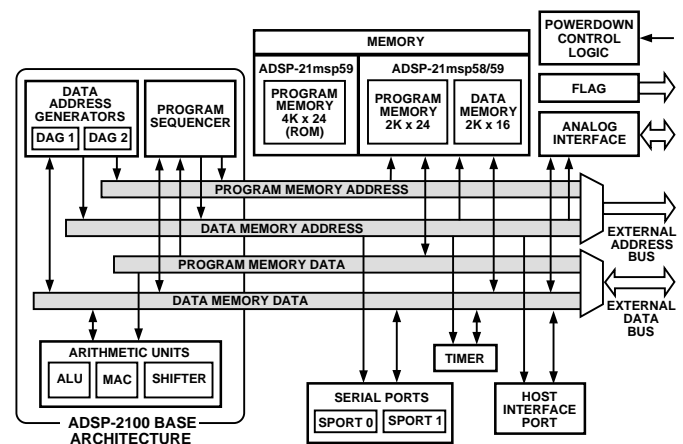

GENERAL DESCRIPTION

The ADSP-21msp58 and ADSP-21msp59 Mixed-Signal Processors (MSProcessor® DSPs) are fully integrated, single-chip DSPs complete with a high performance analog front end. The ADSP-21msp58/59 Family is optimized for voice band applications such as Speech Compression, Speech Processing, Speech Recognition, Text-to-Speech, and Speech-to-Text conversion.

The ADSP-21msp58/59 combines the ADSP-2100 base architecture (three computation units, data address generators, and program sequencer) with two serial ports, a host interface port, an analog front end, a programmable timer, extensive interrupt capability, and on-chip program and data memory.

The ADSP-21msp58 provides 2K words (24-bit) of program RAM and 2K words (16-bit) of data memory. The ADSP-21msp59 provides an additional 4K words (24-bit) of program ROM. The ADSP-21msp58/59 integrates a high performance analog codec based on a single chip, voice band codec, the AD28msp02. Powerdown circuitry is also provided to meet the low power needs of battery operated portable equipment. The ADSP-21msp58/59 is available in a 100-pin TQFP package (thin quad flat package).

In addition, the ADSP-21msp58/59 supports new instructions, which include bit manipulations—bit set, bit clear, bit toggle, bit test—new ALU constants, new multiplication instruction (x squared), biased rounding, and global interrupt masking.

MSProcessor is a registered trademark of Analog Devices, Inc.

REV. 0

Information furnished by Analog Devices is believed to be accurate and reliable. However, no responsibility is assumed by Analog Devices for its use, nor for any infringements of patents or other rights of third parties which may result from its use. No license is granted by implication or otherwise under any patent or patent rights of Analog Devices.

© Analog Devices, Inc., 1995

One Technology Way, P.O. Box 9106, Norwood, MA 02062-9106, U.S.A.
Tel: 617/329-4700 Fax: 617/326-8703

seven wait states are automatically generated. This allows, for example, a 38 ns ADSP-21msp58/59 to use a 250 ns EPROM as external boot memory. Multiple programs can be selected and loaded from the EPROM with no additional hardware. The on-chip program memory can also be initialized through the HIP.

The ADSP-21msp58/59 features a general purpose flag output whose state is controlled through software. You can use this output to signal an event to an external device. In addition, the data input and output pins on SPORT1 can be alternatively configured as an input and an output flag.

A programmable interval timer can generate periodic interrupts. A 16-bit count register (TCOUNT) is decremented every n cycles, where $n-1$ is a scaling value stored in an 8-bit register (TSCALE). When the value of the count register reaches zero, an interrupt is generated and the count register is reloaded from a 16-bit period register (TPERIOD).

The ADSP-21msp58/59 instruction set provides flexible data moves and multifunction (one or two data moves with a computation) instructions. Every instruction can be executed in a single processor cycle. The ADSP-21msp58/59 uses an algebraic syntax for ease of coding and readability. A comprehensive set of development tools supports program development.

Serial Ports

The ADSP-21msp58/59 processors include two synchronous serial ports (SPORT0 and SPORT1) for serial communications and multiprocessor communication.

Here is a brief list of the capabilities of the ADSP-21msp58/59 SPORTs. Refer to the *ADSP-2100 Family User's Manual* for further details.

- SPORTs are bidirectional with a separate, double-buffered transmit and receive section.
- SPORTs can use an external serial clock or generate their own clock internally.
- SPORTs have independent framing for the transmit and receive sections. Sections run in a frameless mode or with frame synchronization signals internally or externally generated. Frame sync signals are programmed to be active high or low, with either of two pulse widths and timings.
- SPORTs support serial data word lengths from 3 to 16 bits and provide optional A-law and μ -law companding according to CCITT recommendation G.711.
- SPORTs receive and transmit sections generate separate interrupts when the SPORTs are ready to read or write new data.
- SPORTs can receive and transmit an entire circular buffer of data with only one overhead cycle per data word (Autobuffering Mode). An interrupt is generated after a complete data buffer transfer.
- SPORT0 has a multichannel interface to selectively receive and transmit a 24- or 32-word, time-division multiplexed serial bit stream.
- SPORT1 can be reconfigured as two external interrupt inputs ($\overline{IRQ0}$ and $\overline{IRQ1}$) and the Flag In and Flag Out signals (FI, FO). The internally generated serial clock may still be used in this configuration.

Pin Descriptions

The ADSP-21msp58 and ADSP-21msp59 are available in a 100-lead TQFP package. Table I contains the pin descriptions.

Table I. ADSP-21msp58/59 Pin List

Pin Group Name	# of Pins	Input/Output	Function
<i>Digital Pins</i>			
Address	14	O	Address output for program, data and boot memory spaces
Data	24	I/O	Data I/O pins for program and data memories. Input only for boot memory space, with two MSBs used as boot space addresses.
\overline{RESET}	1	I	Processor reset input
$\overline{IRQ2}$	1	I	External interrupt request #2
\overline{BR}	1	I	External bus request input
\overline{BG}	1	O	External bus grant output
\overline{PMS}	1	O	External program memory select
\overline{DMS}	1	O	External data memory select
\overline{BMS}	1	O	Boot memory select
\overline{RD}	1	O	External memory read enable
\overline{WR}	1	O	External memory write enable
MMAP	1	I	Memory map select
CLKIN, XTAL	2	I	External clock or quartz crystal input
CLKOUT	1	O	Processor clock output
\overline{HACK}	1	O	HIP acknowledge output
HSEL	1	I	HIP select input
BMODE	1	I	Boot mode select ($0 = Standard EPROM Booting, 1 = HIP Booting$)
HMD0	1	I	Bus strobe select ($0 = \overline{RD}/\overline{WR}, 1 = RW/DS$)
HMD1	1	I	HIP address/data mode select ($0 = Separate, 1 = Multiplexed$)
\overline{HRD}/HRW	1	I	HIP read strobe <i>or</i> read/write select
\overline{HWR}/HDS	1	I	HIP write strobe <i>or</i> host data strobe select
HD7-0/ HAD7-0	8	I/O	HIP data <i>or</i> HIP data and address
HA2/ALE	1	I	Host address 2 <i>or</i> address latch enable
HA1-0/ (unused)	2	I	Host address 1 and 0 inputs
SPORT0	5	I/O	Serial port 0 pins (<i>TFS0, RFS0, DT0, DR0, SCLK0</i>)
SPORT1	5	I/O	Serial port 1 pins (<i>TFS1, RFS1, DT1, DR1, SCLK1</i>)

or

ADSP-21msp58/59

Pin Group Name	# of Pins	Input/Output	Function
$\overline{\text{IRQ0}}$ (<i>RFS1</i>)	1	I	External interrupt request #0
$\overline{\text{IRQ1}}$ (<i>TFS1</i>)	1	I	External interrupt request #1
SCLK1	1	O	Programmable clock output
FI (<i>DR1</i>)	1	I	Flag input pin
FO (<i>DT1</i>)	1	O	Flag output pin
FL0	1	O	General purpose flag output pin
V _{DD}	4		Digital power supply pins
GND	5		Ground pins
$\overline{\text{PWD}}$	1	I	Powerdown pin
<i>Analog Pins</i>			
VIN _{NORM}	1	I	Input terminal of the NORM amplifier for the encoder section (ADC)
VIN _{AUX}	1	I	Input terminal of the AUX amplifier for the encoder section (ADC)
Decouple	1	I	Ground reference of the NORM and AUX amplifiers for the encoder section (ADC)
VOU _{Tp}	1	O	Noninverting output terminal of the differential amplifier from the decoder section (DAC)
VOU _{TN}	1	O	Inverting output terminal of the differential amplifier from the decoder section (DAC)
V _{REF}	1	O	Output voltage reference
REF __ FILTER	1	O	Voltage reference external bypass filter node
V _{CC}	1		Analog power supply
GND _A	2		Analog ground

Host Interface Port

The ADSP-21msp58/59 host interface port (HIP) is a parallel I/O port that allows for an easy connection to a host processor. Through the HIP, the ADSP-21msp58/59 can be used as a memory-mapped peripheral to a host computer. The HIP can be thought of as an area of dual-ported memory, or mailbox registers, that allows communication between the computational core of the ADSP-21msp58/59 and the host computer.

The host interface port is completely asynchronous. The host processor can write data into the HIP while the ADSP-21msp58/59 is operating at full speed.

The HIP can be configured with the following pins:

- BMODE (when MMAP = 0) determines whether the ADSP-21msp58/59 boots from the host processor (through the HIP) or external EPROM (through the data bus).
- HMD0 configures the bus strobes as separate read and write strobes, or a single read/write select and a host data strobe.
- HMD1 selects separate address (3-bit) and data (8-bit) buses, or a multiplexed 8-bit address/data bus with address latch enable.

Tying these pins to appropriate values configures the ADSP-21msp58/59 for straight-wire interface to a variety of industry-standard microprocessors and microcomputers.

When the host processor writes an 8-bit value to the HIP, the upper eight bits of the HIP registers are all zeros. For additional information, refer to the *ADSP-2100 Family User's Manual*, Chapter 7, for information about 8-bit configuration.

HIP Operation

The HIP contains six data registers (HDR5-0) and two status registers (HSR7-6) with an associated HMASK register for masking interrupts from individual HIP data registers. The HIP data registers are memory-mapped in the internal data memory of the ADSP-21msp58/59. HIP transfers can be managed using either interrupts or polling. These registers are shown in the section "ADSP-21msp58/59 Registers." The two status registers provide status information to both the ADSP-21msp58/59 and the host processor. HSR7 contains a software reset bit that can be set by the ADSP-21msp58/59 and the host.

The HIP allows a software reset to be performed by the host processor. The internal software reset signal is asserted for five ADSP-21msp58/59 cycles.

The HIP generates an interrupt whenever an HDR register receives data from a host processor write. It also generates an interrupt when the host processor has performed a successful read of any HDR. The read/write status of the HDRs is also stored in the HSR registers.

The HMASK register bits can be used to mask the generation of read or write interrupts from individual HDR registers. Bits in the IMASK register enable and disable all HIP read interrupts or all HIP write interrupts. So, for example, a write to HDR4 will cause an interrupt only if both the *HDR4 Write* bit in HMASK and the *HIP Write* interrupt enable bit in IMASK are set.

The HIP provides a second method of booting the ADSP-21msp58/59 in which the host processor loads instructions into the HIP. The ADSP-21msp58/59 automatically transfers the data, in this case opcodes, to internal program memory. The BMODE pin determines whether the ADSP-21msp58/59 boots from the host processor through the HIP or from external EPROM over the data bus.

Interrupts

The interrupt controller lets the processor respond to interrupts and reset with a minimum of overhead. The ADSP-21msp58/59 provides up to three external interrupt input pins, $\overline{\text{IRQ0}}$, $\overline{\text{IRQ1}}$, and $\overline{\text{IRQ2}}$. $\overline{\text{IRQ2}}$ is always available as a dedicated pin; SPORT1 may be reconfigured for $\overline{\text{IRQ1}}$ and $\overline{\text{IRQ0}}$ and the flag. The ADSP-21msp58/59 also supports internal interrupts from the timer, the host interface port, the serial ports, the analog interface, and the powerdown control circuit. The interrupts are internally prioritized and individually maskable (except for powerdown and $\overline{\text{RESET}}$). The input pins can be programmed for either level- or edge-sensitivity. The priorities and vector addresses for the interrupts are shown in Table II; the interrupt registers are shown in Figure 2.

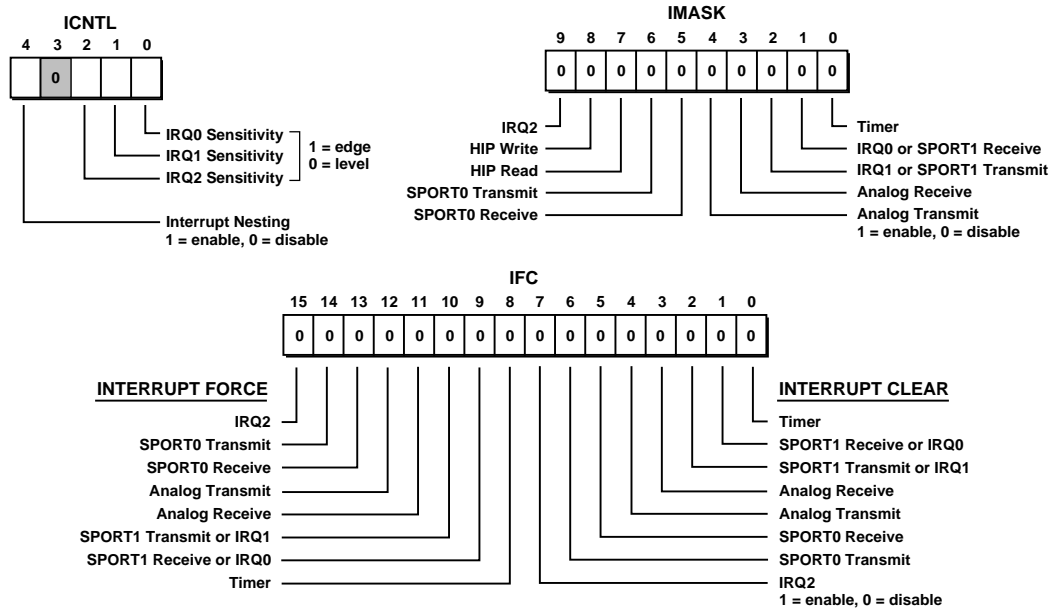

Figure 2. Interrupt Registers

Table II. Interrupt Priority & Interrupt Vector Addresses

Source of Interrupt	Interrupt Vector Address (Hex)
Reset (or Power-Up with PUCR = 1)	0000 (Highest Priority)
Powerdown (Nonmaskable)	002C
IRQ2	0004
HIP Write	0008
HIP Read	000C
SPORT0 Transmit	0010
SPORT0 Receive	0014
Analog Interface Transmit	0018
Analog Interface Receive	001C
SPORT1 Transmit or (IRQ1)	0020
SPORT1 Receive or (IRQ0)	0024
Timer	0028 (Lowest Priority)

Interrupts can be masked or unmasked with the IMASK register. Individual interrupt requests are logically ANDed with the bits in IMASK; the highest priority unmasked interrupt is then selected. The powerdown interrupt is non-maskable.

The interrupt control register, ICNTL, allows the external interrupts to be set as either edge- or level-sensitive. Interrupt service routines can either be nested (with higher priority interrupts taking precedence) or be processed sequentially (with only one interrupt service active at a time).

The interrupt force and clear register, IFC, is a write-only register used to force an interrupt or clear a pending edge-sensitive interrupt.

On-chip stacks preserve the processor status and are automatically maintained during interrupt handling. The stack is twelve levels deep to allow interrupt nesting.

Register bit values shown in Figure 2 are the default bit values after reset. If no values are shown, the bits are indeterminate at reset. Reserved bits are shown in gray; these bits should always be written with zeros.

The following instructions allow global enable or disable servicing of the interrupts (including powerdown), regardless of the state of IMASK. Disabling the interrupts does not affect autobuffering.

ENA INTS;
DIS INTS;

Interrupt servicing is enabled on processor reset.

System Interface

Figure 3 shows a basic system configuration with the ADSP-21msp58/59, two serial devices, a host processor, a boot EPROM, optional external program and data memories, and an analog interface. Up to 15K words of data memory and 16K words of program memory can be supported. Programmable wait state generation allows the processor to interface easily to slow memories. The ADSP-21msp58/59 also provides one external interrupt and two serial ports or three external interrupts and one serial port.

Clock Signals

The ADSP-21msp58/59 CLKIN input may be driven by a crystal or by a TTL-compatible external clock signal.

The CLKIN input may not be halted, changed in frequency during operation, or operated at any frequency other than the one specified. Operating the ADSP-21msp58/59 at any other frequency changes the analog performance, which is not tested or supported.

If an external clock is used, it should be a TTL-compatible signal running at half the instruction rate. The signal should be connected to the processor's CLKIN input; in this case, the XTAL input must be left unconnected.

The ADSP-21msp58/59 uses an input clock with a frequency equal to half the instruction rate; a 13 MHz input clock yields a 38.46 ns processor cycle (which is equivalent to 26 MHz). Normally, instructions are executed in a single processor cycle.

All device timing is relative to the internal instruction clock rate, which is indicated by the CLKOUT signal when enabled. The

ADSP-21msp58/59

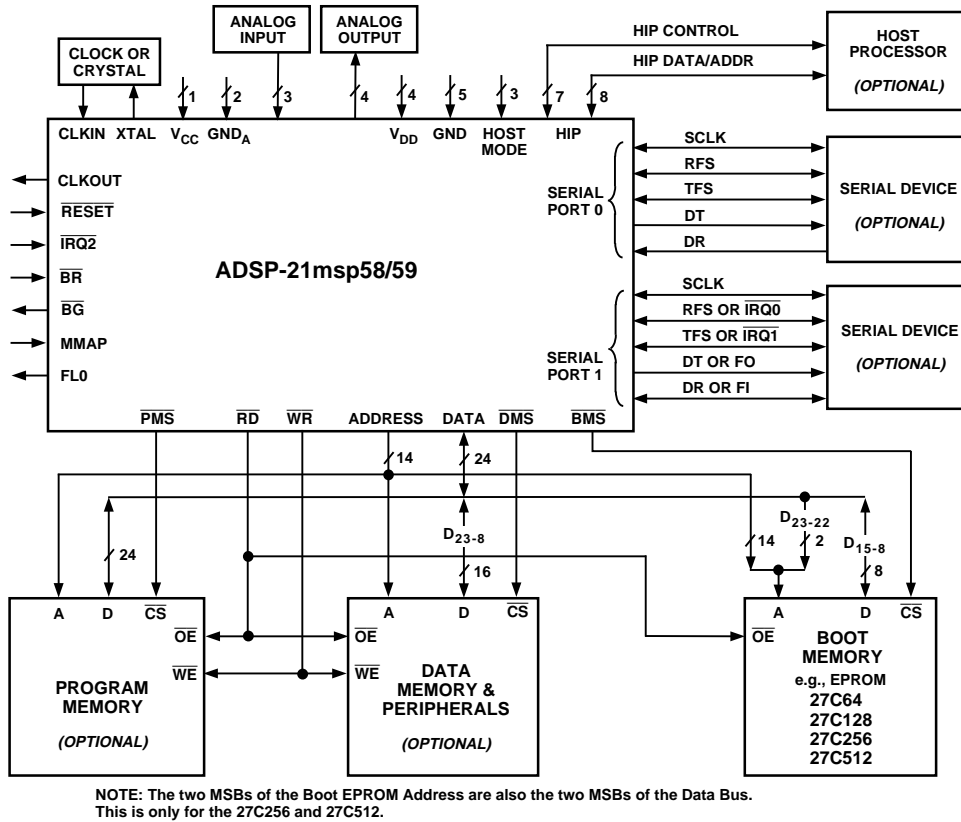

Figure 3. ADSP-21msp58/59 Basic System Configuration

CLKOUT signal is enabled and disabled by the CLKODIS bit in the SPORT0 Autobuffer Control Register, DM[0x3FF3]. Because the ADSP-21msp58/59 includes an on-chip oscillator circuit, an external crystal may also be used. The crystal should be connected across the CLKIN and XTAL pins, with two capacitors connected as shown in Figure 4. A parallel-resonant, fundamental frequency, microprocessor-grade crystal should be used.

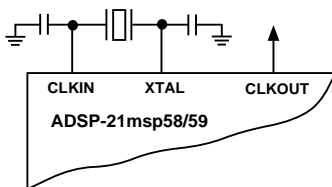

Figure 4. External Crystal Connections

Reset

The $\overline{\text{RESET}}$ signal initiates a master reset of the ADSP-21msp58/59. The $\overline{\text{RESET}}$ signal must be asserted during the power-up sequence to assure proper initialization. $\overline{\text{RESET}}$ during initial power-up must be held long enough to allow the processor's internal clock to stabilize. If $\overline{\text{RESET}}$ is asserted at any time after power-up, the clock continues to run and does not require stabilization time.

The power-up sequence is defined as the total time required for the crystal oscillator circuit to stabilize after a valid V_{DD} is applied to the processor and for the internal phase-locked loop (PLL) to lock onto the specific crystal frequency. A minimum of

2000 CLKIN cycles will ensure that the PLL has locked (this does not, however, include the crystal oscillator start-up time). During this power-up sequence, the $\overline{\text{RESET}}$ signal should be held low. On any subsequent resets, the $\overline{\text{RESET}}$ signal must meet the minimum pulse width specification, t_{RSP} .

The $\overline{\text{RESET}}$ input contains some hysteresis; however, if you use an RC circuit to generate your $\overline{\text{RESET}}$ signal, the use of an external Schmidt trigger is recommended.

The master $\overline{\text{RESET}}$ sets all internal stack pointers to the empty stack condition, masks all interrupts, and clears the MSTAT register. When $\overline{\text{RESET}}$ is released, if there is no pending bus request and the chip is configured for booting ($\text{MMAP} = 0$), the boot loading sequence is performed. Then the first instruction is fetched from internal program memory location 0x0000 and execution begins.

Program Memory Interface

The on-chip program memory address bus (PMA) and on-chip program memory data bus (PMD) are multiplexed with the on-chip data memory buses (DMA, DMD), creating a single external data bus and a single external address bus. The data and address busses are three-stated when the DSP runs from internal memory. Refer to the *ADSP-2100 Family User's Manual*, Chapter 10, "Memory Interface" for a detailed explanation. The 14-bit address bus directly addresses up to 16K words. See "Program Memory Maps" for details on program memory addressing.

The program memory data lines are bidirectional. The program memory select ($\overline{\text{PMS}}$) signal indicates access to program memory and can be used as a chip select signal. The write ($\overline{\text{WR}}$) signal indicates a write operation and is used as a write strobe.

The read (\overline{RD}) signal indicates a read operation and is used as a read strobe or output enable signal. An external program memory access should always be qualified with the \overline{PMS} signal.

The ADSP-21msp58/59 writes data from its 16-bit registers to 24-bit program memory using the PX register to provide the lower eight bits. When the processor reads data (not instructions) from 24-bit program memory to a 16-bit data register, the lower eight bits are placed in the PX register. The program memory interface can generate zero to seven wait states for external memory devices; the default is seven wait states after RESET.

Program Memory Maps

ADSP-21msp58

ADSP-21msp58 Program memory can be mapped in two ways, depending on the state of the MMAP pin. Figure 5 shows the two configurations. When MMAP = 0, internal RAM occupies 2K words beginning at address 0x0000; external program memory uses the remaining 14K words beginning at address 0x0800. In this configuration, the boot loading sequence (described in "Boot Memory Interface") is automatically initiated when RESET is released.

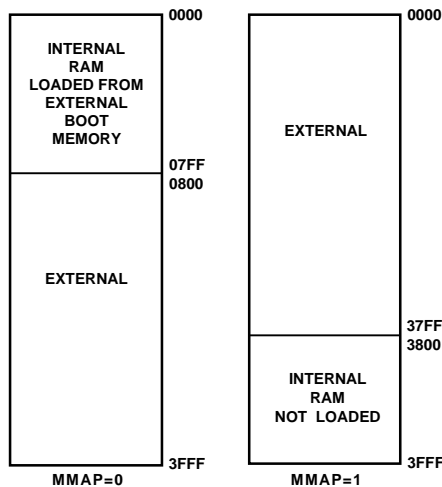

Figure 5. ADSP-21msp58 Program Memory Maps

When MMAP = 1, 14K words of external program memory begin at address 0x0000 and internal RAM is located in the upper 2K words, beginning at address 0x3800. In this configuration, the boot loading sequence does not take place; execution begins immediately after \overline{RESET} .

ADSP-21msp59

The ADSP-21msp59 is functionally identical to the ADSP-21msp58. The ADSP-21msp59 includes an additional 4K by 24-bit mask programmable ROM (see Figure 6). The ROM can be used to hold program instructions or data and can be accessed twice in one instruction cycle if necessary. The ROM always resides at locations PM[0x0800] through PM[0x17FF] regardless of the state of the MMAP pin. Sixteen addresses at the end of ROM (0x17F0–0x17FF) are reserved for Analog Devices' use. The ROM is enabled by setting the ROMENABLE bit in the Data Memory Wait State control register, DM[0x3FFE]. When the ROMENABLE bit is set to 1, addressing program memory in this range will access the on-chip ROM. When set to 0, addressing program memory in this range will access external program memory. The ROMENABLE bit is set to 0 on chip reset.

Data Memory Interface

The data memory address bus (DMA) is 14 bits wide. The bi-directional external data bus is 24 bits wide, with the upper 16 bits used for data memory data (DMD) transfers.

The data memory select (\overline{DMS}) signal indicates access to data memory and can be used as a chip select signal. The write (\overline{WR}) signal indicates a write operation and can be used as a write strobe. The read (\overline{RD}) signal indicates a read operation and can be used as a read strobe or output enable signal.

The ADSP-21msp58/59 supports memory-mapped I/O, with the peripherals memory mapped into the data or program memory address spaces and accessed by the processor in the same manner.

Data Memory Map

The on-chip data memory RAM resides in the 2K words beginning at address 0x3000, as shown in Figure 7. In addition, data memory locations from 0x3800 to the end of data memory at 0x3FFF are reserved. Control registers for the system, timer,

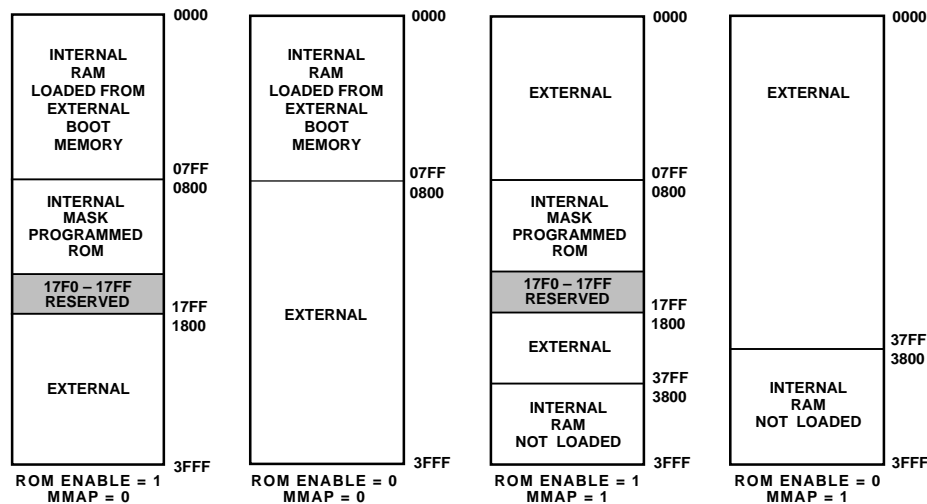

Figure 6. ADSP-21msp59 Program Memory Maps

ADSP-21msp58/59

wait-state configuration, host interface port, codec, and serial port operations are located in this region of memory.

The remaining 12K of data memory is external. External data memory is divided into three zones, each associated with its own wait-state generator. By mapping peripherals into different zones, you can accommodate peripherals with different wait-state requirements. All zones default to seven wait states after RESET.

For compatibility with other ADSP-2100 Family processors, bit definitions for DWAIT3 and DWAIT4 are shown in the Data Memory Wait State Control register, but they are not used by the ADSP-21msp58/59.

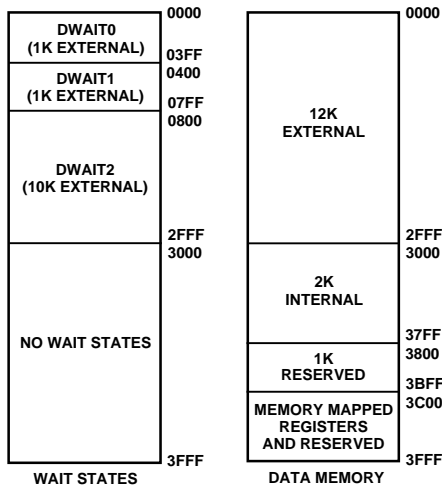

Figure 7. ADSP-21msp58/59 Data Memory Maps

Boot Memory Interface

The ADSP-21msp58/59 can load on-chip memory from external boot memory space. The boot memory space consists of 64K by 8-bit space, divided into eight separate 8K by 8-bit pages. Three bits in the System Control Register select which page is loaded by the boot memory interface. Another bit in the System Control Register allows the user to force a boot loading sequence under software control. Boot loading from Page 0 after RESET is initiated automatically if MMAP = 0.

The boot memory interface can generate zero to seven wait states; it defaults to seven wait states after RESET. This allows the ADSP-21msp58/59 to boot from a single low cost EPROM such as a 27C256. Program memory is booted one byte at a time and converted to 24-bit program memory words.

The $\overline{\text{BMS}}$ and $\overline{\text{RD}}$ signals are used to select and to strobe the boot memory interface. Only 8-bit data is read over the data bus, on pins D8–D15. To accommodate addressing up to eight pages of boot memory, the two MSBs of the data bus are used in the boot memory interface as the two MSBs of the boot memory address.

The ADSP-2100 Family Assembler and Linker support the creation of programs and data structures requiring multiple boot pages during execution.

$\overline{\text{RD}}$ and $\overline{\text{WR}}$ must always be qualified by $\overline{\text{PMS}}$, $\overline{\text{DMS}}$, or $\overline{\text{BMS}}$ to ensure the correct program, data, or boot memory accessing.

HIP Booting

The ADSP-21msp58/59 can also boot programs through the Host Interface Port. If BMODE = 1 and MMAP = 0, the ADSP-21msp58/59 boots from the HIP. If BMODE = 0, the ADSP-21msp58/59 boots through the data bus (in the same way as the ADSP-2101), as described above in “Boot Memory Interface.” For additional information about HIP booting, refer to the *ADSP-2100 Family User’s Manual*, Chapter 7, “Host Interface Port.”

The ADSP-2100 Family Development Software includes a utility program called the HIP Splitter. This utility allows the creation of programs that can be booted through the ADSP-21msp58/59 HIP, in a similar fashion as EPROM-bootable programs generated by the PROM Splitter utility.

Bus Request and Bus Grant

The ADSP-21msp58/59 can relinquish control of the data and address buses to an external device. When the external device requires access to memory, it asserts the bus request signal ($\overline{\text{BR}}$). If the ADSP-21msp58/59 is not performing an external memory access, it responds to the active $\overline{\text{BR}}$ input in the following processor cycle by

- three-stating the data and address buses and the $\overline{\text{PMS}}$, $\overline{\text{DMS}}$, $\overline{\text{BMS}}$, $\overline{\text{RD}}$, and $\overline{\text{WR}}$ output drivers,
- asserting the bus grant ($\overline{\text{BG}}$) signal, and
- halting program execution.

If GoMode is enabled, the ADSP-21msp58/59 will not halt program execution until it encounters an instruction that requires an external memory access.

If the ADSP-21msp58/59 is performing an external memory access when the external device asserts the $\overline{\text{BR}}$ signal, then it will not three-state the memory interfaces or assert the $\overline{\text{BG}}$ signal until the cycle after the access is completed, which can be up to eight cycles later depending on the number of wait states. The instruction does not need to be completed when the bus is granted. If a single instruction requires two external memory accesses, the bus will be granted between the two accesses.

When the $\overline{\text{BR}}$ signal is released, the processor releases the $\overline{\text{BG}}$ signal, which reenables the output drivers, and continues program execution from the point where it stopped.

The bus request feature operates at all times, including when the processor is booting and when RESET is active.

LOW POWER OPERATION

The ADSP-21msp58/59 has three low power modes that significantly reduce the power dissipation when the device operates under standby conditions. These modes are:

- Powerdown
- Idle
- Slow Idle

The CLKOUT pin may also be disabled to reduce external power dissipation. The CLKOUT pin is controlled by Bit 14 of SPORT0 Autobuffer Control Register, DM[0x3FF3].

Powerdown

The ADSP-21msp58/59 has a low power feature that lets the processors enter a very low power dormant state through hardware or software control. Here is a brief list of powerdown features. Refer to the *ADSP-2100 Family User’s Manual*, Chapter 9,

“System Interface” for detailed information about the power-down feature.

- Powerdown mode holds the processor in CMOS standby with a maximum current of less than 100 μ A in some modes.
- Quick recovery from powerdown. In some modes, the processor can begin executing instructions in less than 100 CLKIN cycles.
- Support for an externally generated TTL or CMOS processor clock. The external clock can continue running during powerdown without affecting the lowest power rating and 100 CLKIN cycle recovery.
- Support for crystal operation includes disabling the oscillator to save power (the processor automatically waits 4096 CLKIN cycles for the crystal oscillator to start and stabilize), and letting the oscillator run to allow 100 CLKIN cycle start-up.
- Powerdown is initiated by either the powerdown pin ($\overline{\text{PWD}}$) or the software powerdown force bit.
- Interrupt support allows an unlimited number of instructions to be executed before optionally powering down. The powerdown interrupt also can be used as a non-maskable, edge-sensitive interrupt.
- Context clear/save control lets the processor continue where it left off or start with a clean context when leaving the powerdown state.
- The $\overline{\text{RESET}}$ pin also can be used to terminate powerdown, and the host software reset feature can be used to terminate powerdown under certain conditions.
- Setting the CLKODIS bit (Bit 14 of the SPORT0 Autobuffer Control Register [0x3FF3]) disables the CLKOUT pin during powerdown.

Idle

When the ADSP-21msp58/59 is in the Idle Mode, the processor waits indefinitely in a low power state until an interrupt occurs. When an unmasked interrupt occurs, it is serviced; execution then continues with the instruction following the *IDLE* instruction.

Slow Idle

The *IDLE* instruction is enhanced on the ADSP-21msp58/59 to let the processor’s internal clock signal be slowed, further reducing power consumption. The reduced clock frequency, a programmable fraction of the normal clock rate, is specified by a selectable divisor given in the *IDLE* instruction. The format of the instruction is

IDLE (*n*);

where $n = 16, 32, 64,$ or 128 . This instruction keeps the processor fully functional, but operating at the slower clock rate. While it is in this state, the processor’s other internal clock signals, such as SCLK, and timer clock, are reduced by the same ratio. CLKOUT remains at the normal rate; it is not reduced. The default form of the instruction, when no clock divisor is given, is the standard *IDLE* instruction.

When the *IDLE* (*n*) instruction is used, it effectively slows down the processor’s internal clock and thus its response time to incoming interrupts—the 1-cycle response time of the standard idle state is increased by n , the clock divisor. When an enabled interrupt is received, the ADSP-21msp58/59 remains in the idle state for up to a maximum of n processor cycles ($n = 16, 32, 64,$ or 128) before resuming normal operation.

When the *IDLE* (*n*) instruction is used in systems that have an externally generated serial clock (SCLK), the serial clock rate may be faster than the processor’s reduced internal clock rate. Under these conditions, interrupts must not be generated at a faster rate than can be serviced, due to the additional time the processor takes to come out of the idle state (a maximum of n processor cycles).

Standalone ROM Execution (ADSP-21msp59 Only)

When the MMAP and BMODE pins both are set to 1, the ROM is automatically enabled and execution commences from program memory location 0x0800 at the start of ROM. This feature lets an embedded design operate without external memory components. To operate in this mode, the ROM coded program must copy an interrupt vector table to the appropriate locations in program memory RAM. In this mode, the ROM enable bit defaults to 1 during reset.

Table III. Boot Summary Table

	<i>BMODE</i> = 0	<i>BMODE</i> = 1
MMAP = 0	Boot from EPROM, then execution starts at internal RAM location 0x0000	Boot from HIP, then execution starts at internal RAM location 0x0000
MMAP = 1	No booting, execution starts at external memory location 0x0000	Stand Alone Mode, execution starts at internal ROM location 0x0800

Ordering Procedure For ADSP-21msp59 ROM Processors

To place an order for a custom ROM-coded ADSP-21msp59 processor, you must:

1. Complete the following forms contained in the *ADSP ROM Ordering Package*, available from your Analog Devices sales representative:
 ADSP-21msp59 ROM Specification Form
 ROM Release Agreement
 ROM NRE Agreement & Minimum Quantity Order (MQO)
 Acceptance Agreement for Preproduction ROM Products
2. Return the forms to Analog Devices along with two copies of the Memory Image File (.EXE file) of your ROM code. The files must be supplied on two 3.5" or 5.25" floppy disks for the IBM PC (DOS 2.01 or higher).
3. Place a purchase order with Analog Devices for nonrecurring engineering changes (NRE) associated with ROM product development.

After this information is received, it is entered into Analog Devices’ ROM Manager System that assigns a custom ROM model number to the product. This model number will be branded on all prototype and production units manufactured to these specifications.

To minimize the risk of code being altered during this process, Analog Devices verifies that the .EXE files on both floppy disks are identical, and recalculates the checksums for the .EXE file entered into the ROM Manager System. The checksum data, in the form of a ROM Memory Map, a hard copy of the .EXE file, and a ROM Data Verification form are returned to you for inspection.

ADSP-21msp58/59

A signed ROM Verification Form and a purchase order for production units are required prior to any product being manufactured. Prototype units may be applied toward the minimum order quantity.

Upon completion of prototype manufacture, Analog Devices will ship prototype units and a delivery schedule update for production units. An invoice against your purchase order for the NRE charges is issued at this time.

There is a charge for each ROM mask generated and a minimum order quantity. Consult your sales representative for details. A separate order must be placed for parts of a specific package type, temperature range, and speed grade.

ANALOG INTERFACE

The analog interface contains encoding circuitry (ADC), decoding circuitry (DAC), and processor interface logic. A block diagram of the ADSP-21msp58/59 analog section is shown in Figure 8.

The analog interface is configured through the Analog Control Register and the Analog Autobuffer/Powerdown Register (refer to "ADSP-21msp58/59 Registers"). The Analog Control Register DM[0x3FEE] configures the programmable gain stages, the analog input multiplexer, and the analog interface powerdown state. Note that the unused bits must be cleared to zero.

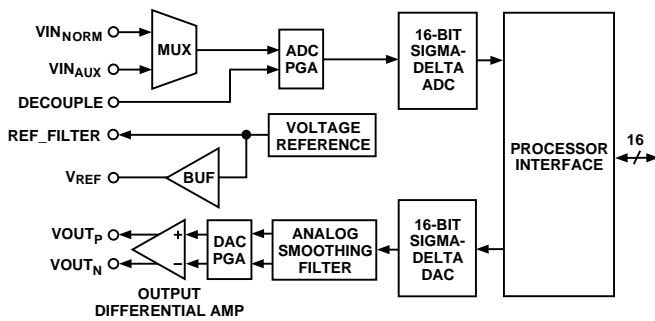

Figure 8. Analog Interface Block Diagram

A/D Conversion

The A/D conversion circuitry of the analog interface consists of an analog multiplexer, a programmable gain amplifier (ADC PGA), and a 16-bit sigma-delta analog-to-digital converter (ADC).

Analog Input Multiplexer and Amplifiers

The analog multiplexer selects either the NORM or AUX input to the ADC's sigma-delta modulator. The inputs should be ac coupled.

The ADC PGA may be used to additionally increase the signal level by +6 dB, +20 dB, or +26 dB. This gain is selected by bit 9 and bit 0 (IG0, IG1) of the analog control register. Input signal level to the sigma-delta ADC should not exceed the V_{INMAX} specification.

Analog-To-Digital Converter

The analog interface's analog-to-digital converter consists of a 4th-order analog sigma-delta modulator, an anti-aliasing decimation filter, and an optional digital high-pass filter. For a detailed description of the ADC components, refer to the *ADSP-2100 Family User's Manual*, Chapter 8, "Analog Interface."

Bit 10 of the Analog Control Register (0x3FEE) may be set to add an offset to the input of the ADC sigma-delta converter. This offset moves ADC sigma-delta idle tones out of the 4.0 kHz speech band range. This added offset must be removed by the ADC high-pass filter. Therefore, the high-pass filter must be inserted when you use the offset feature.

D/A Conversion

The D/A conversion circuitry of the analog interface consists of a sigma-delta digital-to-analog converter (DAC), an analog smoothing filter, a programmable gain amplifier (DAC PGA), and a differential output amplifier.

Digital-to-Analog Converter

The digital-to-analog converter consists of an optional digital high-pass filter, an anti-imaging interpolation filter, and a sigma-delta modulator. The digital filters and the sigma-delta modulator have the same characteristics as the filters and modulator of the ADC. For detailed description of the DAC components, refer to the *ADSP-2100 Family User's Manual*, Chapter 8, "Analog Interface."

Analog Smoothing Filter and Programmable Gain Amplifier

The analog smoothing filter consists of a 3rd-order switched capacitor filter with a 3 dB point at approximately 25 kHz.

The DAC's programmable gain amplifier (DAC PGA) can be used to adjust the output signal level by -15 dB to +6 dB in 3 dB increments. This gain is selected by bits 2-4 (OG0, OG1, OG2) of the analog control register.

Differential Output Amplifier

The analog output signal (V_{OUTP} , V_{OUTN}) is produced by a differential amplifier. The differential amplifier meets specifications for loads greater than 2 k Ω and has a maximum differential output swing of ± 3.156 V peak-to-peak (3.17 dBm0). The DAC will drive loads smaller than 2 k Ω , but with degraded performance.

The output signal is dc-biased to the on-chip voltage reference (V_{REF}) and can be ac-coupled directly to a load or dc-coupled to an external amplifier.

The V_{OUTP} , V_{OUTN} output must be used as a differential signal otherwise performance will be severely compromised. Do not use either pin as a single-ended output.

OPERATING THE ANALOG INTERFACE

The analog interface is operated with several memory-mapped control and data registers. The ADC and DAC I/O data is received and transmitted through two memory-mapped data registers. The data can also be autobuffered directly into (or from) on-chip memory. In both cases, the I/O processing is interrupt driven; two interrupts are dedicated to the analog interface, one for the ADC receive data and one for the DAC transmit data.

The ADSP-21msp58/59 must have an input clock frequency of 13 MHz. At this frequency, analog-to-digital and digital-to-analog converted data is transmitted at an 8 kHz rate with a single 16-bit word transmitted every 125 μ s.

For detailed information about the analog interface, refer to the *ADSP-2100 Family User's Manual*, Chapter 8, "Analog Interface."

Autobuffering

In some applications, it is advantageous to perform block data transfers between the analog converters and processor memory. Analog interface autobuffering enables the automatic transfer of data blocks directly from the ADC to on-chip processor data memory or from on-chip processor data memory directly to the DAC.

ADC and DAC Interrupts

The analog interface generates two interrupts that signal either: (1) a 16-bit, 8 kHz analog-to-digital or digital-to-analog conversion has been completed, or (2) an autobuffer block transfer has been completed (i.e., the data buffer contents have been received or transferred).

When an analog interrupt occurs, the processor vectors to the addresses listed in Table II, *Interrupt Priority & Interrupt Vector Addresses*.

The ADC receive and DAC transmit interrupts occur at an 8 kHz rate, indicating when the data registers should be accessed. On the receive side, the ADC interrupt is generated each time an A/D conversion cycle is completed and the 16-bit data word is available in the ADC receive register. On the transmit side, the DAC interrupt is generated each time an D/A conversion cycle is completed and the DAC transmit register is ready for the next 16-bit data word.

Both interrupts are generated simultaneously at an 8 kHz rate, occurring every 3250 instruction cycles with a 13 MHz internal processor clock. The interrupts are generated continuously, starting when the analog interface is powered up by setting the

APWD bits (Bits 5 and 6) to one in the analog control register. Because both interrupts occur simultaneously, only one should be enabled (in IMASK) to vector to a single service routine that handles transmit and receive data. However, when using autobuffer transfers, both interrupts should be enabled.

ADSP-21msp58/59 REGISTERS

Figure 9 summarizes the ADSP-21msp58/59 registers. Some registers store values. For example, AX0 stores an ALU operand; I4 stores a DAG2 pointer. Other registers consist of control bits and fields, or status flags. For example ASTAT contains status flags from arithmetic operations, and fields in DWAIT control the number of wait states for different zones of data memory.

A secondary set of registers in all computational units allows a single-cycle context switch.

The bit and field definitions for control and status registers are given in the rest of this section, except IMASK, ICNTL, and IFC, which are defined earlier in this data sheet. The system control register, DWAIT register, timer registers, HIP control registers, HIP data registers, and SPORT control registers are all mapped into data memory locations; that is, you access these registers by reading and writing data memory locations rather than register names. The particular data memory address is shown with each memory-mapped register.

Register bit values shown on the following pages are the default bit values after reset. If no values are shown, the bits are indeterminate at reset. Reserved bits are shown in gray; these bits should always be written with zeros.

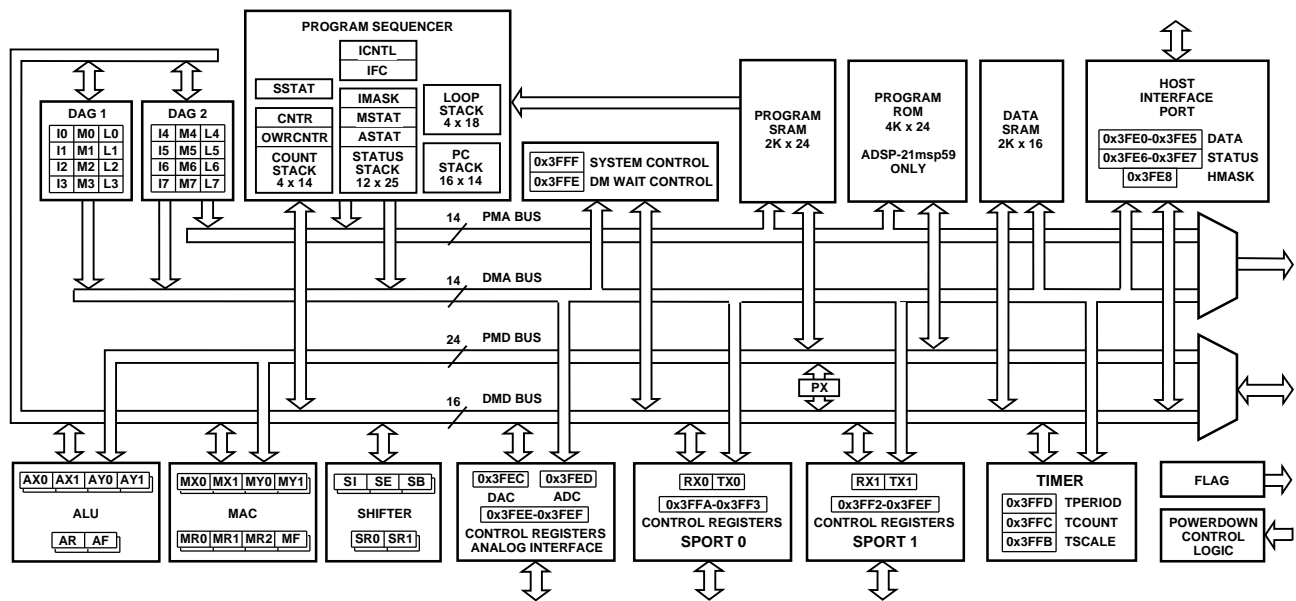
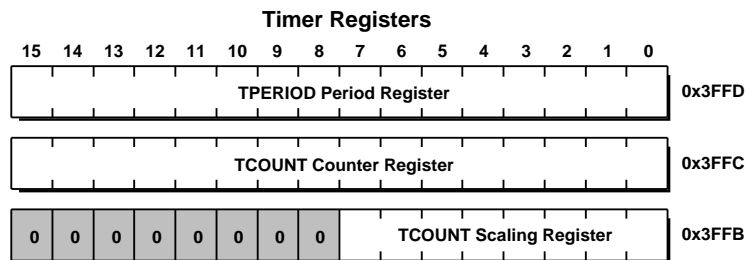
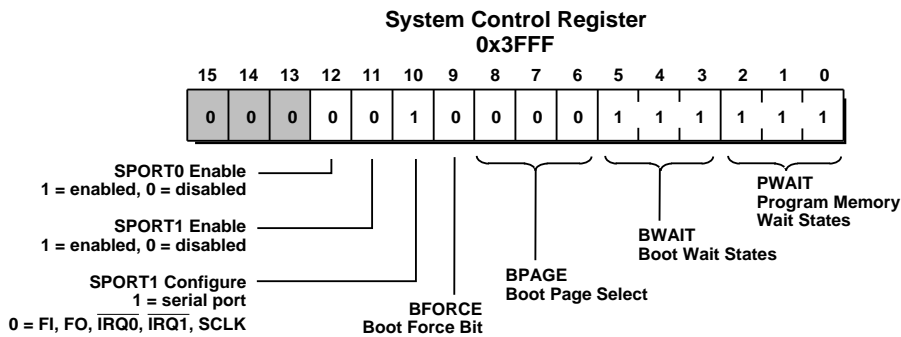
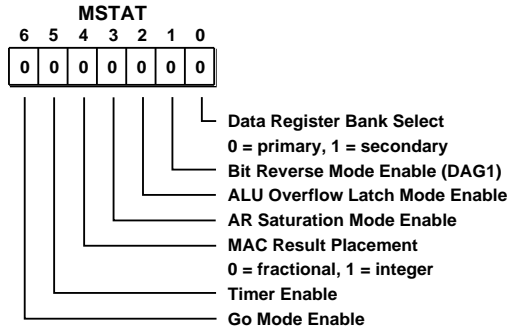
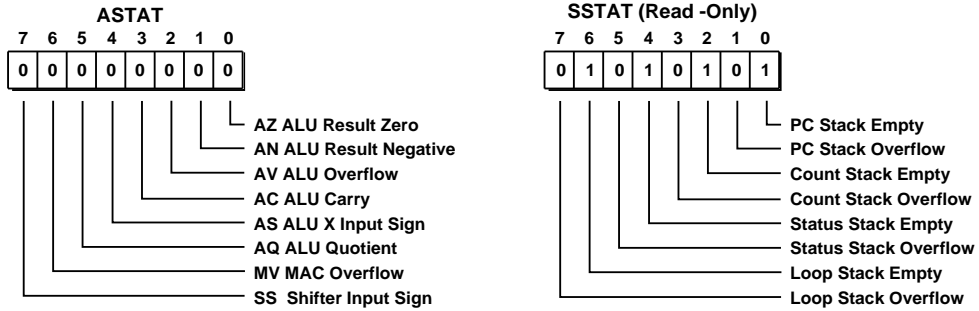

Figure 9. ADSP-21msp58/59 Registers

ADSP-21msp58/59



Control Registers

**ROM Enable/Data Memory Wait State
Control Register
0x3FFE**

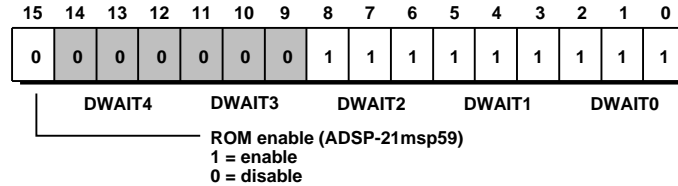

SPORT0 Multichannel Receive Word Enable Registers

1 = Channel Enabled
0 = Channel Ignored

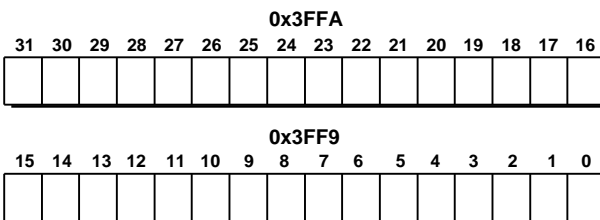

SPORT0 Multichannel Transmit Word Enable Registers

1 = Channel Enabled
0 = Channel Ignored

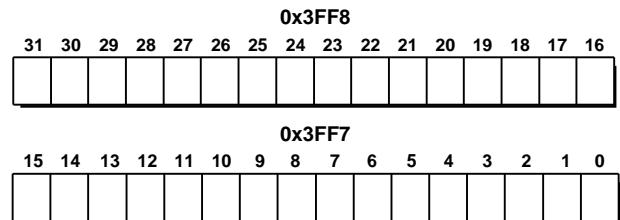

**SPORT0 Control Register
0x3FF6**

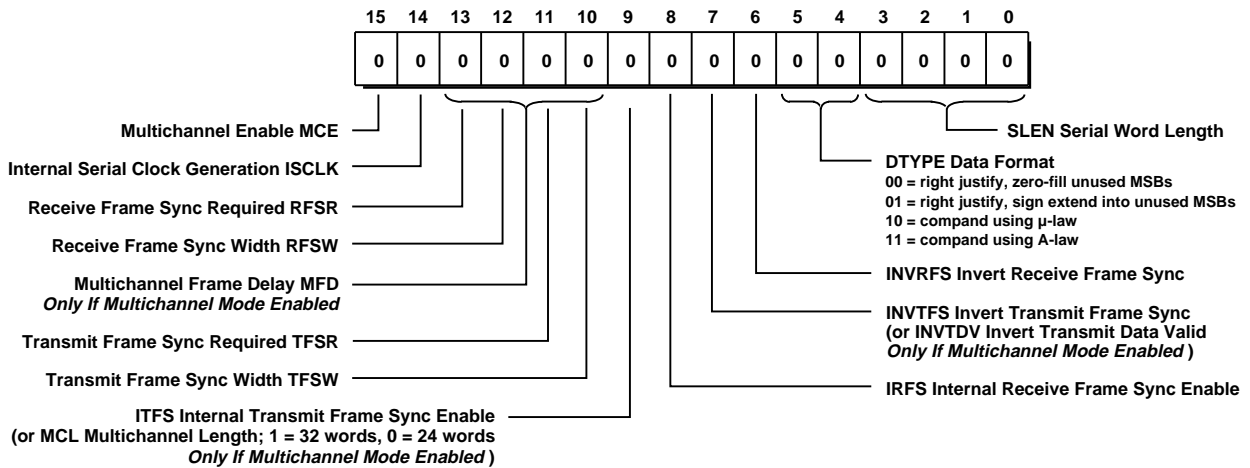

Control Registers

SPORT0 SCLKDIV
Serial Clock Divide Modulus
0x3FF5

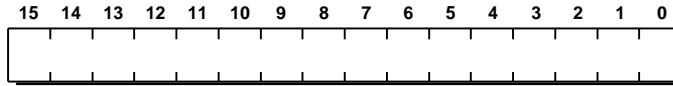

SPORT0 RFSDIV
Receive Frame Sync Divide Modulus
0x3FF4

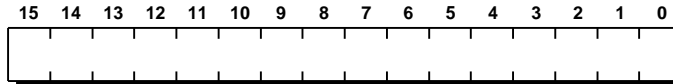

SPORT0 Autobuffer Control Register
0x3FF3

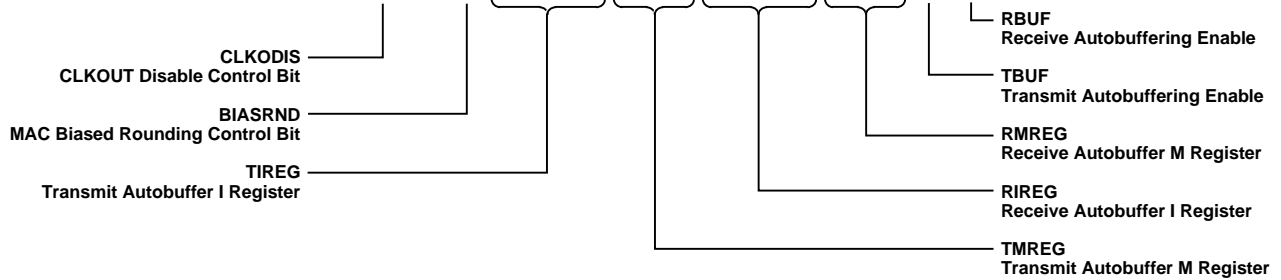
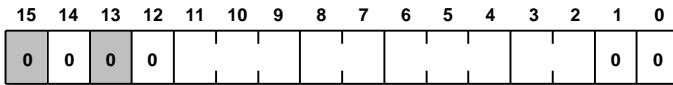

SPORT1 Control Register
0x3FF2

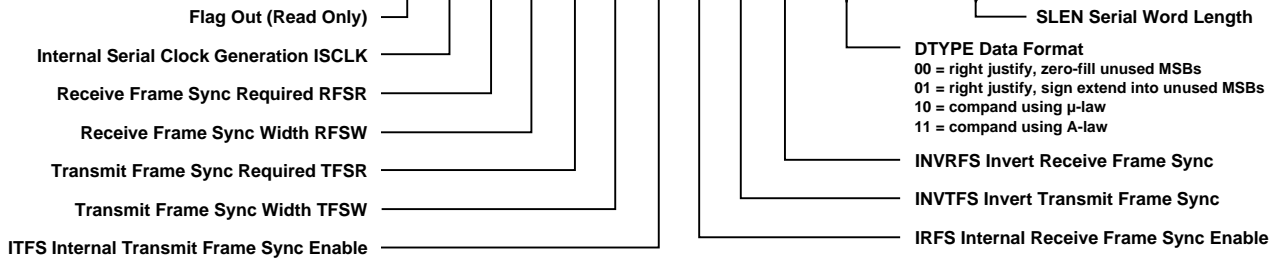
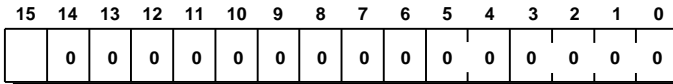

Control Registers

SPORT1 SCLKDIV
Serial Clock Divide Modulus
0x3FF1

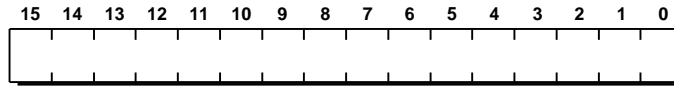

SPORT1 RFSDIV
Receive Frame Sync Divide Modulus
0x3FF0

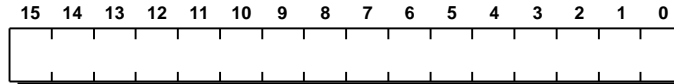

Analog Autobuffer/Powerdown Control Register
0x3FEF

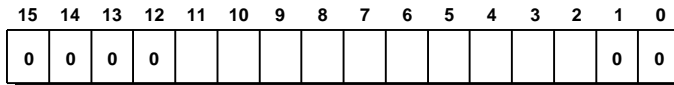

HMASK Register
0x3FE8

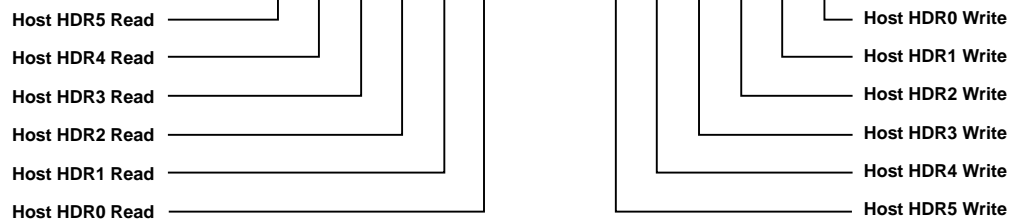
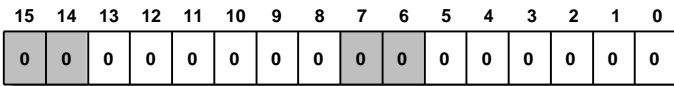

Interrupt Enables
1 = Enable
0 = Disable

Control Registers

ADSP-21msp58/59

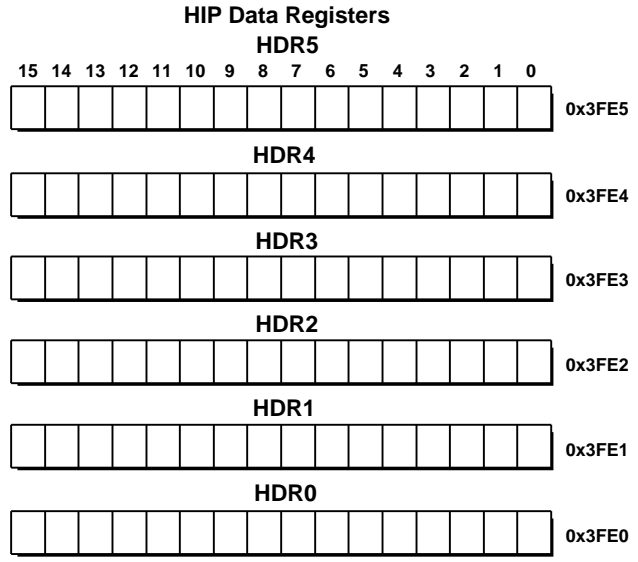
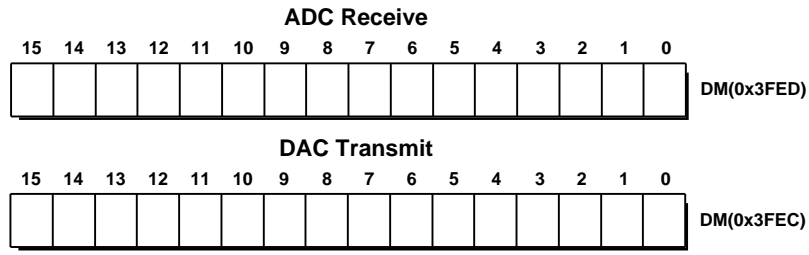
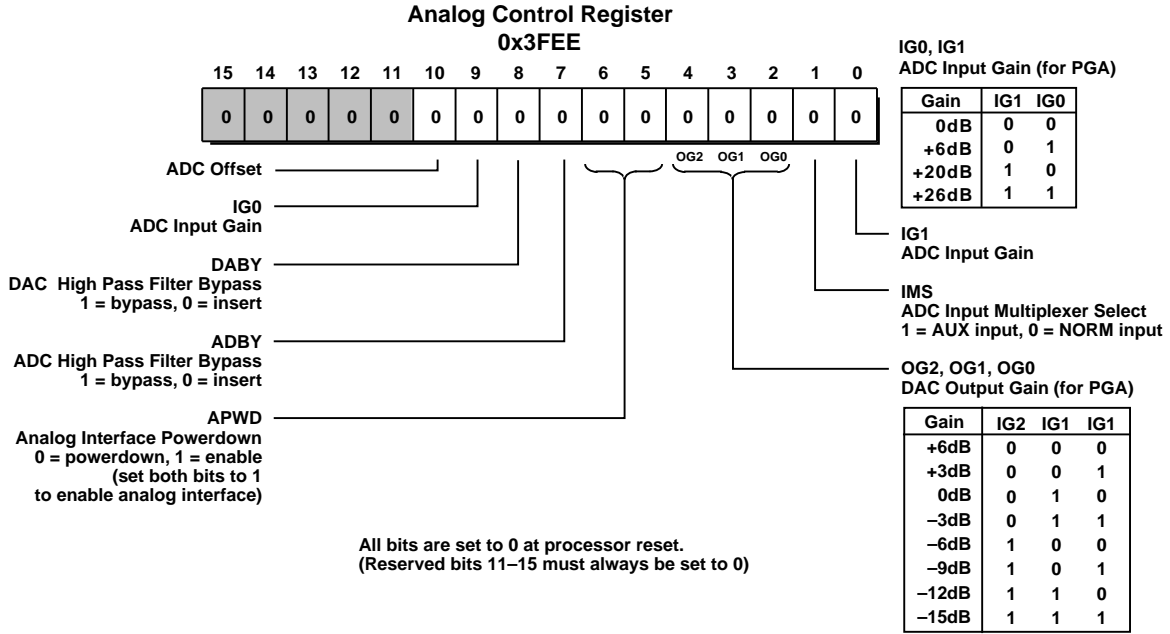

Control Registers

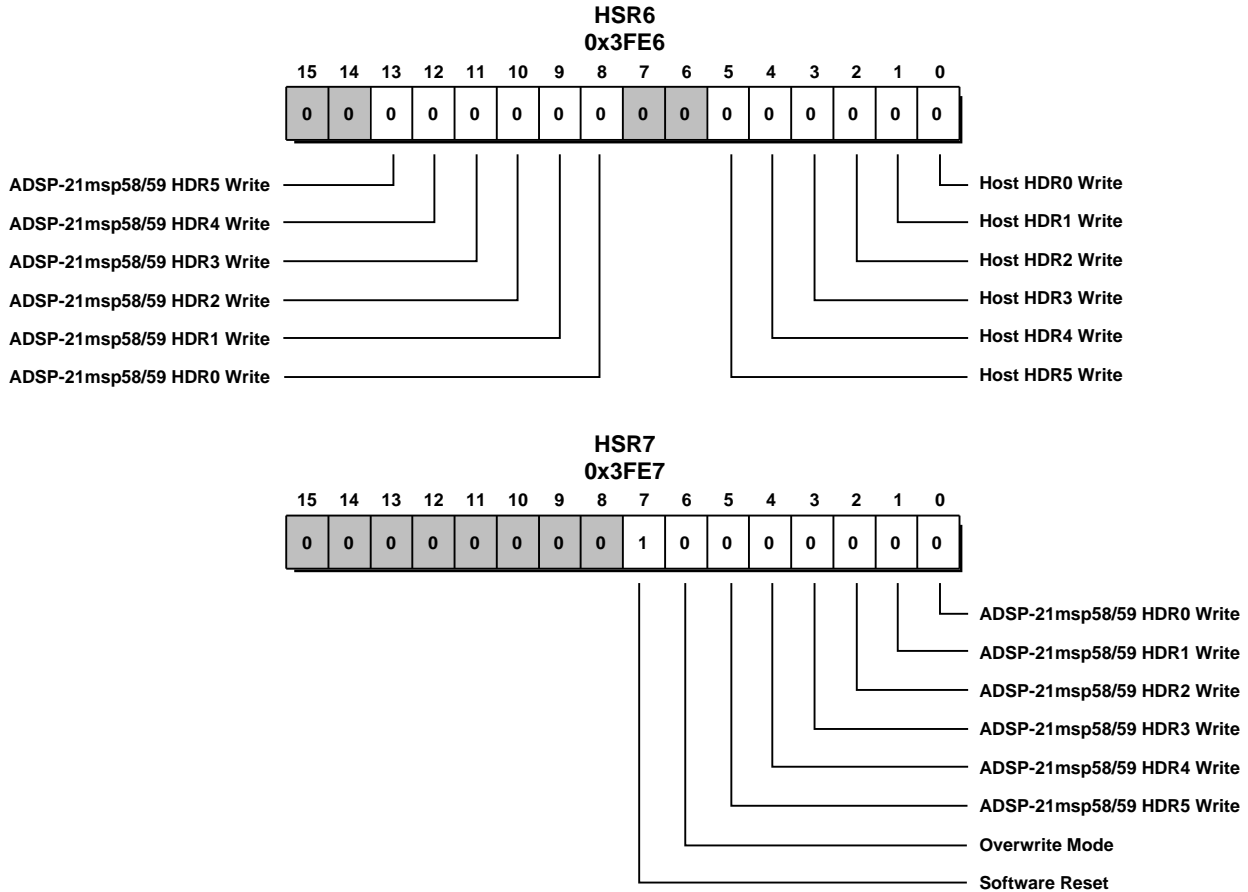

Control Registers

INSTRUCTION SET DESCRIPTION

The ADSP-21msp58/59 assembly language instruction set has an algebraic syntax that was designed for ease of coding and readability. The assembly language, which takes full advantage of the processor's unique architecture, offers the following benefits:

- The algebraic syntax eliminates the need to remember cryptic assembler mnemonics. For example, a typical arithmetic add instruction, such as AR = AX0 + AY0, resembles a simple equation.
- Every instruction assembles into a single 24-bit word and executes in a single cycle.
- The syntax is a superset of the ADSP-2100 Family assembly language and is completely source and object code compatible with other family members. Programs may, however, need to be relocated to utilize internal memory and conform to the ADSP-21msp58/59 interrupt vector and reset vector map.
- Sixteen condition codes are available. For conditional jump, call, return, or arithmetic instructions, the condition can be checked and the operation executed in the same instruction cycle.
- Multifunction instructions allow parallel execution of an arithmetic instruction with up to two fetches and one write to processor memory space during a single instruction cycle.

Consult the *ADSP-2100 Family User's Manual* for a complete description of the syntax and an instruction set reference.

ADSP-21msp58/59 EXTENDED INSTRUCTION SET

The ADSP-21msp58/59 has a number of additional instructions beyond the standard ADSP-2100 Family instruction set. These additional instructions and mathematical operations are described below.

Slow IDLE

Slow IDLE allows slowing the processor's internal clock by a factor of 16, 32, 64, or 128 during IDLE. The instruction source code is specified as follows:

Syntax: IDLE (n);

Permissible Values for n
16, 32, 64, 128

Examples: IDLE;
IDLE (16);

Description: The IDLE instruction causes the processor to wait indefinitely in a low power state until an interrupt occurs. When an unmasked interrupt occurs, it is serviced; execution then continues with the instruction following the IDLE instruction. The optional value provides a "slow idle" feature; slowing the clock down by the factor set with the value.

Interrupt Enable and Disable Instructions

The ADSP-21msp58/59 supports an interrupt enable instruction and interrupt disable instruction. Interrupts are enabled by default at reset. The interrupt enable instruction source code is specified as follows:

ADSP-21msp58/59

Syntax: ENA INTS;

Description: Executing the ENA INTS instruction allows all unmasked interrupts to be serviced again.

The interrupt disable instruction source code is specified as follows:

Syntax: DIS INTS;

Description: Reset enables interrupt servicing. Executing the DIS INTS instruction causes all interrupts to be masked without changing the contents of the IMASK register. Disabling interrupts does not affect the autobuffer circuitry, which will operate normally whether or not interrupts are enabled. The disable interrupt instruction masks all user interrupts including the powerdown interrupt.

Extended ALU and Multiplier Operations

The following extended computation operations are available only on the ADSP-21msp58/59 processor. The term “base instruction set” refers to the computations and instructions available on all ADSP-21xx processors.

Additional Constants for ALU Operations

A new set of numerical constants may be used in all nonmulti-function ALU operations (except DIVS and DIVQ) using both X and Y operands. The instruction source code is specified as follows:

Syntax: [IF condition] | AR | = xop function | yop |
| AF | | constant |

Permissible xops

AX0, AX1, AR, MR0, MR1, MR2, SR0, SR1

Permissible functions

ADD/ADD with CARRY, SUBTRACT X-Y/SUBTRACT X-Y with BORROW, SUBTRACT Y-X/SUBTRACT Y-X with BORROW, AND, OR, XOR

Permissible yops (base instruction set)

AY0, AY1, AF

Permissible yops and constants (extended instruction set)

AY0, AY1, AF, 0, 1, 2, 4, 8, 16, 32, 64, 128, 256, 512, 1024, 2048, 4096, 8192, 16384, 32767, -2, -3, -5, -9, -17, -33, -65, -129, -257, -513, -1025, -2049, -4097, -8193, -16385, -32768

Examples: AR = AR+1;
AR = MR1 - 33;
IF GT AF = AX1 OR 16;

Description: Test the optional condition and, if true, perform the specified function. If false then perform a no-operation. Omitting the condition performs the function unconditionally. The operands are contained in the data registers specified in the instruction or optionally a constant may be used.

Additional Constants for ALU PASS Operation

A new set of numerical constants may be used in the PASS instruction. The instruction source code is specified as follows:

Syntax: [IF condition] | AR | = pass | yop |
| AF | | constant |

Permissible yops (base instruction set)

AY0, AY1, AF

Permissible yops and constants (extended instruction set)

AY0, AY1, AF, 0, 1, 2, 3, 4, 5, 7, 8, 9, 15, 16, 17, 31, 32, 33, 63, 64, 65, 127, 128, 129, 255, 256, 257, 511, 512, 513, 1023,

1024, 1025, 2047, 2048, 2049, 4095, 4096, 4097, 8191, 8192, 8193, 16383, 16384, 16385, 32766, 32767, -1, -2, -3, -4, -5, -6, -8, -9, -10, -16, -17, -18, -32, -33, -34, -64, -65, -66, -128, -129, -130, -256, -257, -258, -512, -513, -514, -1024, -1025, -1026, -2048, -2049, -2050, -4096, -4097, -4098, -8192, -8193, -8194, -16384, -16385, -16386, -32767, -32768

Examples: IF GE AR = PASS AY0;
IF EQ AF = PASS -1025;

Description: Test the optional condition and, if true, pass the source operand unmodified through the ALU block and store in the destination location. If the condition is not true, perform a no-operation. Omitting the condition performs the *pass* unconditionally. The source operand is contained in the data registers specified in the instruction or optional constant.

The PASS instruction performs the transfer to the AR register and affect the status flag; this instruction is different from a register move operation which does not affect any status flags. PASS 0 is one method of clearing AR. PASS 0 can also be combined in a multifunction instruction in conjunction with memory reads and writes to clear AR.

Note: The ALU status flags (in the ASTAT register) are not defined for the execution of this instruction when using the constant values other than 0, 1, and -1.

ALU Bit Operations

The additional constants for ALU operations allow you to code bit test, set, clear, and toggle operations through careful choice of the constant and ALU function. For streamlined programming, the source code for these operations can also be specified as:

Syntax: [IF condition] | AR | = | TSTBIT n of xop; |
| AF | | SETBIT n of xop; |
| CLBIT n of xop; |
| TGBIT n of xop; |

Permissible xops

AX0, AX1, AR, MR0, MR1, MR2, SR0, SR1

Permissible n Values (0 = LSB)

0, 1, 2, 3, 4, 5, 6, 7, 8, 9, 10, 11, 12, 13, 14, 15

Examples: AF=TSTBIT 5 of AR;
IF NE JUMP SET;
/* JUMP TO SET IF BIT IS SET */

Definitions of Operations

TSTBIT is an AND operation with a 1 in the selected bit

SETBIT is an OR operation with a 1 in the selected bit

CLBIT is an AND operation with a 0 in the selected bit

TGBIT is an XOR operation with a 1 in the selected bit

Result-Free ALU Operations

The result-free ALU operations allow the generation of condition flags based on an ALU operation but discard the result.

The source code for the instruction is specified as follows:

Syntax: NONE = <ALU>;

where <ALU> is any unconditional ALU operation of the 21xx base instruction set (except DIVS or DIVQ). (Note that the additional constant ALU operations of the ADSP-2171/2181 extended instruction set are not allowed.)

Examples: NONE = AX0 – AY0;
NONE = PASS SR0;

Description: Perform the designated ALU operation, set the condition flags, then discard the result value. This allows the testing of register values without disturbing the AR or AF register values.

MAC Operations

A modified MAC operation allows additional type 9 instructions. The conditional ALU/MAC instruction has been modified to allow the X operand to be used as the Y operand as well. This allows a single cycle X^2 , and also ΣX^2 operations.

The new MAC instructions allow the use of any *xop* as both the X and Y operands. The instructions source code is specified as follows:

Syntax: [IF condition] | MR | = | [MR +] | *xop* * *yop* (UU);
| MF | | [MR -] | *xop* (SS);
(RND);

Permissible xops

AR, MR0, MR1, MR2, MX0, MX1, SR0, SR1

Example: IF LT MR=MR+ SR0 * SR0 (SS);

Note: Both X operators must be the same register.

Biased Rounding

A new mode has been added to allow biased rounding in addition to the normal unbiased rounding. When the BIASRND bit is set to 0 the normal unbiased rounding operations occur.

When the BIASRND bit is set to 1, biased rounding occurs instead of the normal unbiased rounding. When operating in biased rounding mode all rounding operations with MR0 set to 0x8000 will round up, rather than only rounding odd MR1 values up. For example:

MR value before RND	biased RND result	unbiased RND result
00-0000-8000	00-0001-8000	00-0000-8000
00-0001-8000	00-0002-8000	00-0002-8000
00-0000-8001	00-0001-8001	00-0001-8001
00-0001-8001	00-0002-8001	00-0002-8001
00-0000-7FFF	00-0000-7FFF	00-0000-7FFF
00-0001-7FFF	00-0001-7FFF	00-0001-7FFF

This mode only has an effect when the MR0 register contains 0x8000, all other rounding operation work normally. This mode was added to allow more efficient implementation of bit specified algorithms which specify biased rounding such as the GSM speech compression routines. Unbiased rounding is preferred for most algorithms.

Note: BIASRND bit is bit twelve of the SPORT0 Autobuffer Control register.

Interrupt Enable

The ADSP-21msp58/59 supports an interrupt enable instruction. Interrupts are enabled by default at reset. The instruction source code is specified as follows:

Syntax: ENA INTS;

Description: Executing the ENA INTS instruction allows all unmasked interrupts to be serviced again.

Interrupt Disable

The ADSP-21msp58/59 supports an interrupt disable instruction. The instruction source code is specified as follows:

Syntax: DIS INTS;

Description: Reset enables interrupt servicing. Executing the DIS INTS instruction causes all interrupts to

be masked without changing the contents of the IMASK register. Disabling interrupts does not affect the autobuffer circuitry, which will operate normally whether or not interrupts are enabled. The disable interrupt instruction masks all user interrupts including the powerdown interrupt.

CIRCUIT DESIGN CONSIDERATIONS

The following sections discuss interfacing analog signals to the ADSP-21msp58/59.

Analog Signal Input

Figure 10 shows the recommended input circuit for the analog input pin (either VIN_{NORM} or VIN_{AUX}). The circuit of Figure 10 implements a first-order low-pass filter (R1C1) with a 3 dB point less than 40 kHz. This is the only filter required external to the processor to prevent aliasing of the sampled signal. Since the ADSP-21msp58/59's sigma-delta ADC uses a highly oversampled approach that transfers the bulk of the anti-aliasing filtering into the digital domain, the off-chip anti-aliasing need only be of low order.

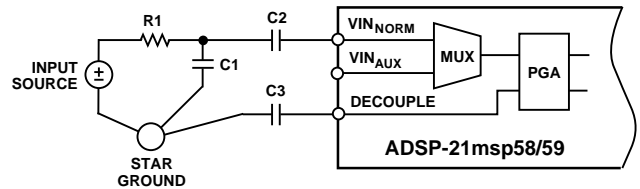

Figure 10. Recommend Analog Input Circuit

The on-chip ADC PGA can be used when there is not enough gain in the input circuit. The PGA gain is set by bits 9 and 0 (IG1, IG0) of the processor's analog control register. The gain must be chosen to ensure that a full-scale input signal (at R1 in Figure 10) produces a signal level at the input to the sigma-delta modulator of the ADC that does not exceed VIN_{MAX} (refer to the "Analog Interface Electrical Characteristics" specifications).

VIN_{NORM} and VIN_{AUX} are biased at the Internal Reference Voltage (nominal of 2.5 V) of the ADSP-21msp58/59, which lets the analog section of the processor operate from a single supply.

The input signal should be ac-coupled with an external capacitor (C2). The value of C2 is determined by the input resistance of the analog input (VIN_{NORM} , VIN_{AUX}) (200 kΩ) and the desired cutoff frequency. The cutoff frequency should be ≤ 30 Hz. The following equation should be used to determine the values of R1, C1, and C2; R1 should be ≤ 2.2 kΩ. C2 should be ≥ 0.027 μF; C3 should be equal to C2.

$$C2 = \frac{1}{2 \pi f_1 R_{IN}}$$

R_{IN} = ADSP-21msp58/59 input resistance (200 kΩ)

f_1 = cutoff frequency <30 Hz

$$R1 = \frac{1}{2 \pi f_2 C1}$$

$$R1 \leq 2.2 \text{ k}\Omega$$

$$f_2 > 20 \text{ kHz} < 40 \text{ kHz}^*$$

$$C1 = \frac{1}{2 \pi f_2 R1}$$

For optimum ADC performance, C1 should be an NPO type capacitor.

*If minimum (<0.1 dB) rolloff at 4 kHz is desired, f_2 should be set to 40 kHz.

ADSP-21msp58/59

Analog Signal Output

The differential analog output (V_{OUT_P} , V_{OUT_N}) is produced by an on-chip differential amplifier which is part of the processor's analog interface. The differential amplifier will meet dynamic specifications for loads greater than 2 k Ω ($R_L \geq 2$ k Ω) and has a maximum differential output voltage swing of ± 3.156 V peak-to-peak (3.17 dBm0). The DAC will drive loads smaller than 2 k Ω , but with degraded dynamic performance. The differential output can be ac-coupled directly to a load or dc-coupled to an external amplifier.

Figure 11 shows a simple circuit providing a differential output with ac coupling. The capacitor of this circuit (C_{OUT}) is optional; if used, its value can be chosen as follows:

$$C_{OUT} = \frac{1}{(60 \pi) R_L}$$

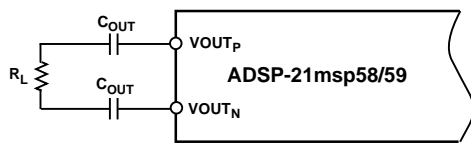

Figure 11. Example Circuit for Differential Output with AC Coupling

The V_{OUT_P} and V_{OUT_N} outputs must be used as differential outputs (do not use either as a single-ended output). Figure 12 shows an example circuit which can be used to convert the differential output to a single-ended output. The circuit uses a differential-to-single-ended amplifier, the Analog Devices SSM2141.

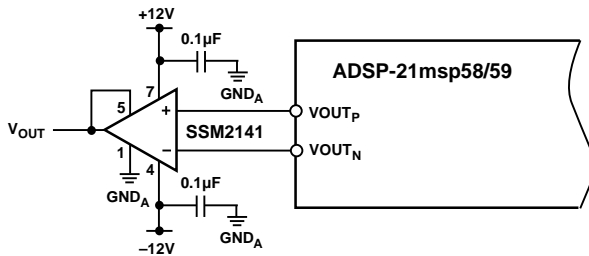

Figure 12. Example Circuit for Single-Ended Output

Voltage Reference Filter Capacitance

Figure 13 shows the recommended reference filter capacitor connections. The capacitor grounds should be connected to the same star ground point shown in Figure 10.

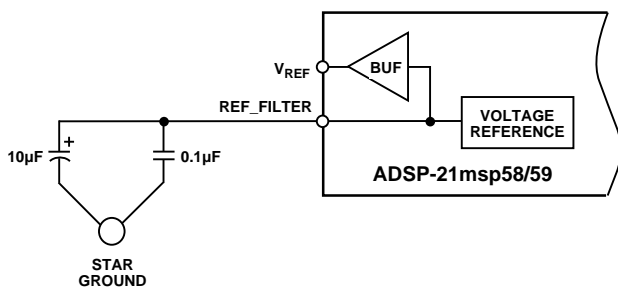

Figure 13. Voltage Reference Filter Capacitor

APPLICATION EXAMPLES

The ADSP-21msp58/59 is ideal for speech processing applications where high performance for analog and digital circuitry is required, but board space is severely limited. The cellular radio handset is one application. Here the ADSP-21msp58/59 can digitize the speech, then perform compression algorithms that sufficiently reduce the bit rate for transmission in a limited radio bandwidth.

DEFINITION OF SPECIFICATIONS

Absolute Gain

Absolute gain is a measure of converter gain for a known signal. Absolute gain is measured with a 1.0 kHz sine wave at 0 dBm0. The absolute gain specification is used as a reference for the gain tracking error specification.

Gain Tracking Error

Gain tracking error measures changes in converter output for different signal levels relative to an absolute signal level. The absolute signal level is 1.0 kHz at 0 dBm0. Gain tracking error at 0 dBm0 is 0 dB by definition.

SNR + THD

Signal-to-noise ratio plus total harmonic distortion is defined to be the ratio of the rms value of the measured input signal to the rms sum of all other spectral components in the frequency range 300 Hz–3400 Hz, including harmonics but excluding dc.

Intermodulation Distortion

With inputs consisting of sine waves at two frequencies, f_a and f_b , any active device with nonlinearities will create distortion products at sum and difference frequencies of $m f_a \pm n f_b$ where $m, n = 0, 1, 2, 3$, etc. Intermodulation terms are those which neither m nor n are equal to zero. The second order terms include $(f_a + f_b)$ and $(f_a - f_b)$, while the third order terms include $(2f_a + f_b)$, $(2f_a - f_b)$, $(f_a + 2f_b)$, and $(f_a - 2f_b)$.

Idle Channel Noise

Idle channel noise is defined as the total signal energy measured at the output of the device when the input is grounded (measured in the frequency range 300 Hz–3400 Hz).

Crosstalk

Crosstalk is defined as the ratio of the rms value of a full-scale signal appearing on one channel to the rms value of the same signal that couples onto the adjacent channel. Crosstalk is expressed in dB.

Power Supply Rejection

Power supply rejection measures the susceptibility of a device to a signal on the power supply. Power supply rejection is measured by modulating a signal on the power supply and measuring the signal at the output (relative to 0 dB). Power supply rejection is defined as the ratio of the rms value of the modulation signal to the rms value of the same signal in the ADC/DAC channel.

Group Delay

Group delay is defined as the derivative of radian phase with respect to radian frequency, $\partial\phi(\omega)/\partial\omega$. Group delay is a measure of the average delay of a system as a function of frequency. A linear system with a constant group delay has a linear phase response. The deviation of group delay away from a constant indicates the degree of nonlinear phase response of the system.

ADSP-21msp58/59–SPECIFICATIONS

RECOMMENDED OPERATING CONDITIONS

ADSP-21msp58/59

Parameter		B Grade		Unit
		Min	Max	
V _{DD}	Supply Voltage	4.50	5.50	V
T _{AMB}	Ambient Operating Temperature	-40	+85	°C

See “Environmental Conditions” for information on thermal specifications.

ELECTRICAL CHARACTERISTICS

Parameter	Test Conditions	Min	Max	Unit
V _{IH}	Hi-Level Input Voltage ^{1, 2}	@ V _{DD} = max	2.0	V
V _{IH}	Hi-Level CLKIN Voltage	@ V _{DD} = max	2.2	V
V _{IL}	Lo-Level Input Voltage ^{1, 3}	@ V _{DD} = min	0.8	V
V _{OH}	Hi-Level Output Voltage ^{1, 4, 5}	@ V _{DD} = min, I _{OH} = -0.5 mA	2.4	V
		@ V _{DD} = min, I _{OH} = -100 μA ⁶	V _{DD} - 0.3	V
V _{OL}	Lo-Level Output Voltage ^{1, 4, 5}	@ V _{DD} = min, I _{OL} = 2 mA	0.4	V
I _{IH}	Hi-Level Input Current ³	@ V _{DD} = max, V _{IN} = V _{DD} max	10	μA
I _{IL}	Lo-Level Input Current ³	@ V _{DD} = max, V _{IN} = 0 V	10	μA
I _{OZH}	Tristate Leakage Current ⁷	@ V _{DD} = max, V _{IN} = V _{DD} max ⁸	10	μA
I _{OZL}	Tristate Leakage Current ⁷	@ V _{DD} = max, V _{IN} = 0 V ⁸	10	μA
I _{DD}	Digital Supply Current (Idle) ^{6, 9}	@ V _{DD} = max, Codec Inactive	18	mA
I _{DD}	Digital Supply Current (Dynamic) ^{9, 10}	@ V _{DD} = max, V _{CC} = max	92	mA
I _{DD}	Digital Supply Current (Powerdown) ⁹	@ V _{DD} = max, See ADSP-2100 Family User's Manual, Chapter 9	100	μA
I _{CC}	Analog Supply Current (Dynamic) ⁹	Codec Active	18	mA
C _I	Input Pin Capacitance ^{3, 11, 12}	@ V _{IN} = 2.5 V, f _{IN} = 1.0 MHz, T _{AMB} = 25°C	8	pF
C _O	Output Pin Capacitance ^{7, 11, 12}	@ V _{IN} = 2.5 V, f _{IN} = 1.0 MHz, T _{AMB} = 25°C	8	pF

NOTES

¹Bidirectional pins: D0-D23, RFS0, RFS1, SCLK0, SCLK1, TFS0, TFS1, HD0-HD7/HAD0-HAD7.

²Input only pins: RESET, IRQ2, BR, MMAP, DR0, DR1, HSEL, HSIZE, BMODE, HMD0, HMD1, HRD/HWR, HWR/HDS, PWD, HA2/ALE, HA1-0.

³Input only pins: CLKIN, RESET, IRQ2, BR, MMAP, DR0, DR1, HSEL, HSIZE, BMODE, HMD0, HMD1, HRD/HWR, HWR/HDS, PWD, HA2/ALE, HA1-0.

⁴Output pins: BG, PMS, DMS, BMS, RD, WR, A0-A13, DT0, DT1, CLKOUT, HACK, FL0.

⁵Although specified for TTL outputs, all ADSP-21msp58/59 outputs are CMOS-compatible and will drive to V_{DD} and GND, assuming no dc loads.

⁶Idle refers to ADSP-21msp58/59 state of operation during IDLE instruction. Deasserted pins are driven to either V_{DD} or GND. Refer to chart in back for lower IDLE currents.

⁷Three-statable pins: A0-A13, D0-D23, PMS, DMS, BMS, RD, WR, DT0, DT1, SCLK0, SCLK1, TFS0, TFS1, RFS0, RSF1, HD0-HD7/HAD0-HAD7.

⁸0 V on BR, CLKIN Active (to force three-state condition).

⁹Current reflects the digital portion of device operating with no output loads and a 2 kΩ load on the analog output (V_{OUTP}, V_{OUTN}).

¹⁰t_{CK} = 76.92 ns, CODEC active, 80% execution type 1 instructions, with random data. For typical figures for digital and analog supply currents, refer to “Power Dissipation” section.

¹¹Guaranteed but not tested.

¹²Output pin capacitance is the capacitive load for any three-stated output pin.

Specifications subject to change without notice.

ADSP-21msp58/59

ABSOLUTE MAXIMUM RATINGS*

Supply Voltage	-0.3 V to +7 V
Input Voltage	-0.3 V to $V_{DD} + 0.3$ V
Output Voltage Swing	-0.3 V to $V_{DD} + 0.3$ V
Operating Temperature Range (Ambient)	-40°C to +85°C
Storage Temperature Range	-65°C to +150°C
Lead Temperature (5 sec)	+280°C

*Stresses above those listed under “Absolute Maximum Ratings” may cause permanent damage to the device. These are stress ratings only, and functional operation of the device at these or any other conditions above those indicated in the operational sections of this specification is not implied. Exposure to absolute maximum rating conditions for extended periods may affect device reliability.

ESD SENSITIVITY

The ADSP-21msp58/59 is an ESD (electrostatic discharge) sensitive device. Electrostatic charges readily accumulate on the human body and equipment and can discharge without detection. Permanent damage may occur to devices subjected to high energy electrostatic discharges.

The ADSP-21msp58/59 features proprietary ESD protection circuitry to dissipate high energy discharges (Human Body Model).

Proper ESD precautions are recommended to avoid performance degradation or loss of functionality. Unused devices must be stored in conductive foam or shunts, and the foam should be discharged to the destination before devices are removed.



TIMING PARAMETERS

GENERAL NOTES

Use the exact timing information given. Do not attempt to derive parameters from the addition or subtraction of others. While addition or subtraction would yield meaningful results for an individual device, the values given in this data sheet reflect statistical variations and worst cases. Consequently, you cannot meaningfully add up parameters to derive longer times.

TIMING NOTES

Switching characteristics specify how the processor changes its signals. You have no control over this timing; it is dependent on the internal design. Timing requirements apply to signals that are controlled outside the processor, such as the data input for a read operation.

Timing requirements guarantee that the processor operates correctly with another device. Switching characteristics tell you what the device will do under a given circumstance. Also, use the switching characteristics to ensure any timing requirement of a device connected to the processor (such as memory) is satisfied.

MEMORY REQUIREMENTS

This chart links common memory device specification names and ADSP-21msp58/59 timing parameters for your convenience.

Parameter Name	Function	Common Memory Device Specification Name
t_{ASW}	A0-A13, \overline{DMS} , \overline{PMS} Setup before \overline{WR} Low	Address Setup to Write Start
t_{AW}	A0-A13, \overline{DMS} , \overline{PMS} Setup before \overline{WR} Deasserted	Address Setup to Write End
t_{WRA}	A0-A13, \overline{DMS} , \overline{PMS} Hold after \overline{WR} Deasserted	Address Hold Time
t_{DW}	Data Setup before \overline{WR} High	Data Setup Time
t_{DH}	Data Hold after \overline{WR} High	Data Hold Time
t_{RDD}	\overline{RD} Low to Data Valid	\overline{OE} to Data Valid
t_{AA}	A0-A13, \overline{DMS} , \overline{PMS} , \overline{BMS} to Data Valid	Address Access Time

FREQUENCY RESPONSE

Frequency (Hz)	ADC Max (dB)	ADC Min (dB)	DAC Max (dB)	DAC Min (dB)
0+	-60.00	N/A	-60.00	N/A
75	-25.00	N/A	-25.00	N/A
150	+0.266	-0.134	+0.015	-0.185
300	+0.272	-0.128	+0.030	-0.170
1000	+0.000	+0.000	+0.000	+0.000
2000	+0.050	-0.350	+0.050	-0.200
3000	-0.200	-0.600	-0.050	-0.300
3400	-0.300	-0.700	-0.090	-0.340
3700	-0.375	-0.775	-0.120	-0.370
3850	-25.00	N/A	-25.00	N/A
4000	-60.00	N/A	-60.00	N/A

NOTES

All specifications relative to absolute gain @ 1.0 kHz.

ADC and DAC high-pass filters *inserted*.

ADC specifications *do not include* RC filter attenuation and assumes an ac coupled input (see "Analog Test Conditions" for RC filter details).

NOISE & DISTORTION

Parameter	Min	Max	Unit	Test Condition
ADC Intermodulation Distortion		-60	dB	m, n = 1 and 2; $f_a = 984$; $f_b = 1047$
DAC Intermodulation Distortion		-70	dB	m, n = 1 and 2; $f_a = 984$; $f_b = 1047$
ADC Idle Channel Noise	65		dBm0	
DAC Idle Channel Noise	72		dBm0	
ADC Crosstalk ¹		-65	dB	ADC input signal level: 1.0 kHz, 0 dBm0 DAC input at idle.
DAC Crosstalk ¹		-65	dB	ADC input signal level: analog ground DAC output signal level: 1.0 kHz, 0 dBm0
ADC Power Supply Rejection ¹		-55	dB	Input signal level at V_{CC} and V_{DD} pins: 1.0 kHz, 100 mV p-p sine wave
DAC Power Supply Rejection ¹		-55	dB	Input signal level at V_{CC} and V_{DD} pins: 1.0 kHz, 100 mV p-p sine wave
ADC Group Delay ¹		1	ms	300 Hz-3000 Hz
DAC Group Delay ¹		1	ms	300 Hz-3000 Hz
ADC SNR and THD	65		dB	1.0 kHz, 0 dBm0
DAC SNR and THD	72		dB	1.0 kHz, 0 dBm0

NOTE

¹Guaranteed but not tested.

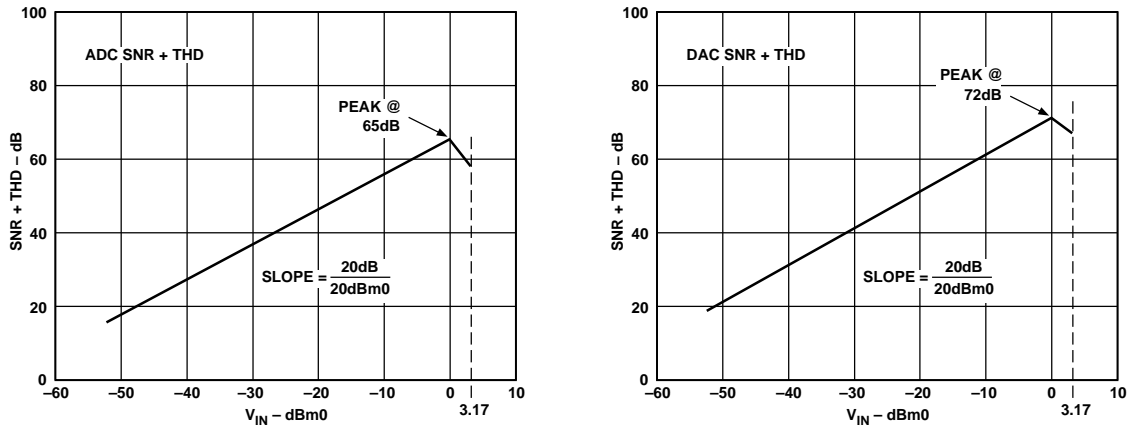

Figure 14. SNR + THD vs. V_{IN}

ADSP-21msp58/59

ANALOG INTERFACE ELECTRICAL CHARACTERISTICS

Symbol	Parameter	Min	Typ	Max	Unit
ADC					
R_i	Input Resistance ^{1, 2} at $V_{IN_{NORM}}$, $V_{IN_{AUX}}$		200		k Ω
$V_{IN_{MAX}}$	Maximum Input Range ^{1, 3}			3.156	V p-p
DAC:					
R_o	Output Resistance ^{1, 4}		2.5		Ω
$V_{O_{OFF}}$	Output DC Offset ⁵	-400		400	mV
V_o	Maximum Voltage Output Swing (p-p) Across R_L				
	Single-Ended ¹			3.156	V
	Differential ¹			6.312	V
R_L	Load Resistance ^{1, 4}	2			k Ω
Reference Buffer:					
Voltage Reference (V_{REF})		2.25		2.75	V
Output Impedance ¹			250		Ω
Capacitive Load ¹				10	nf
PSRR ¹			55		dB

NOTES

Test conditions for all analog interface tests: ADC PGA bypassed, DAC PGA set to 0 dB gain, with 2 k Ω load on analog output (V_{OUT_P} , V_{OUT_N}), $V_{CC} = 5.0$ V.

¹Guaranteed but not tested.

²Varies with PGA setting.

³At input to sigma-delta modulator of ADC.

⁴At V_{OUT_P} , V_{OUT_N} .

⁵Between V_{OUT_P} and V_{OUT_N} .

GAIN

Parameter	Min	Typ	Max	Unit	Test Conditions
ADC Absolute Gain	-0.7	0	0.7	dBm0	1.0 kHz, 0 dBm0
ADC Gain Tracking Error	-0.1	0	0.1	dBm0	1.0 kHz, +3 to -50 dBm0
ADC PGA Relative Gain	-0.6	0	0.6	dBm0	1.0 kHz
DAC Absolute Gain	-0.75	0	0.75	dBm0	1.0 kHz, 0 dBm0
DAC Gain Tracking Error	-0.1	0	0.1	dBm0	1.0 kHz, +3 to -50 dBm0
DAC PGA Relative Gain	-0.6	0	0.6	dBm0	1.0 kHz

Parameter	Min	Max	Unit	
Clock Signals				
t_{CK} is defined as 0.5 t_{CKI}. The ADSP-21msp58/59 uses an input clock with a quency equal to half the instruction rate; a 13 MHz input clock (which is equivalent to 76.92 ns) yields a 38.46 ns processor cycle (equivalent to 26 MHz). t _{CK} values within the range of 0.5 t _{CKI} period should be substituted for all relevant timing parameters to obtain specification value. Example: t _{CKH} = 0.5t _{CK} - 7 ns = 0.5 (38.46 ns) - 7 ns = 12.23 ns.				
Timing Requirement:				
t _{CKI}	CLKIN Period	76.92	125	ns
t _{CKIL}	CLKIN Width Low	20		ns
t _{CKIH}	CLKIN Width High	20		ns
Switching Characteristic:				
t _{CKL}	CLKOUT Width Low	0.5t _{CK} - 7		ns
t _{CKH}	CLKOUT Width High	0.5t _{CK} - 7		ns
t _{CKOH}	CLKIN High to CLKOUT High	0	20	ns
Control Signals				
Timing Requirement:				
t _{RSP}	$\overline{\text{RESET}}$ Width Low	5t _{CK} ¹		ns

NOTES

¹Applies after power-up sequence is complete. Internal phase lock loop requires no more than 2000 CLKIN cycles assuming stable CLKIN (not including crystal oscillator start-up time).

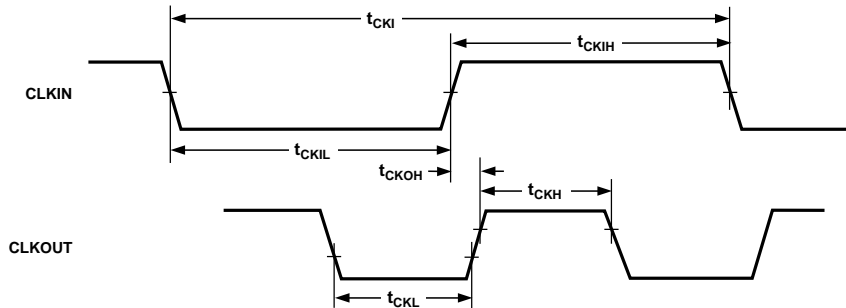

Figure 15. Clock Signals

ADSP-21msp58/59

Parameter	Min	Max	Unit
Interrupts and Flags			
Timing Requirement:			
t_{IFS}	\overline{IRQ}_x or FI Setup before CLKOUT Low ^{1, 2, 3}		ns
t_{IFH}	\overline{IRQ}_x or FI Hold after CLKOUT High ^{1, 2, 3}		ns
Switching Characteristics:			
t_{FOH}	Flag Output Hold after CLKOUT Low ⁴		ns
t_{FOD}	Flag Output Delay from CLKOUT Low ⁴		ns

NOTES

¹If \overline{IRQ}_x and FI inputs meet t_{IFS} and t_{IFH} setup/hold requirements, they will be recognized during the current clock cycle; otherwise the signals will be recognized on the following cycle. (Refer to "Interrupt Controller Operation" in the Program Control chapter of the User's Manual for further information on interrupt servicing.)

²Edge-sensitive interrupts require pulse widths greater than 10 ns; level-sensitive interrupts must be held low until serviced.

³ $\overline{IRQ}_x = \overline{IRQ0}, \overline{IRQ1}, \text{ and } \overline{IRQ2}$.

⁴Flag Output = FL0 and FO.

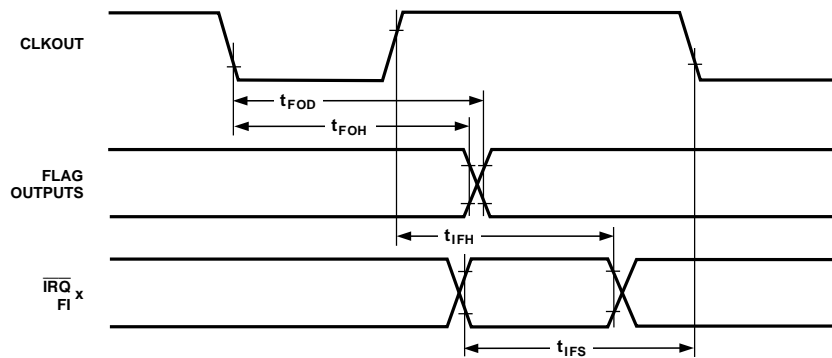

Figure 16. Interrupts and Flags

Parameter	Min	Max	Unit
Bus Request/Grant			
Timing Requirement:			
t_{BH}	$0.25t_{CK} + 2$		ns
t_{BS}	$0.25t_{CK} + 17$		ns
Switching Characteristic:			
t_{SD}		$0.25t_{CK} + 10$	ns
t_{SDB}			ns
t_{SE}	0		ns
t_{SEC}	0		ns
	$0.25t_{CK} - 7$		ns

NOTES

¹ \overline{BR} is an asynchronous signal. If \overline{BR} meets the setup/hold requirements, it will be recognized during the current clock cycle; otherwise the signal will be recognized on the following cycle. Refer to the *ADSP-2100 Family User's Manual* for $\overline{BR}/\overline{BG}$ cycle relationships.

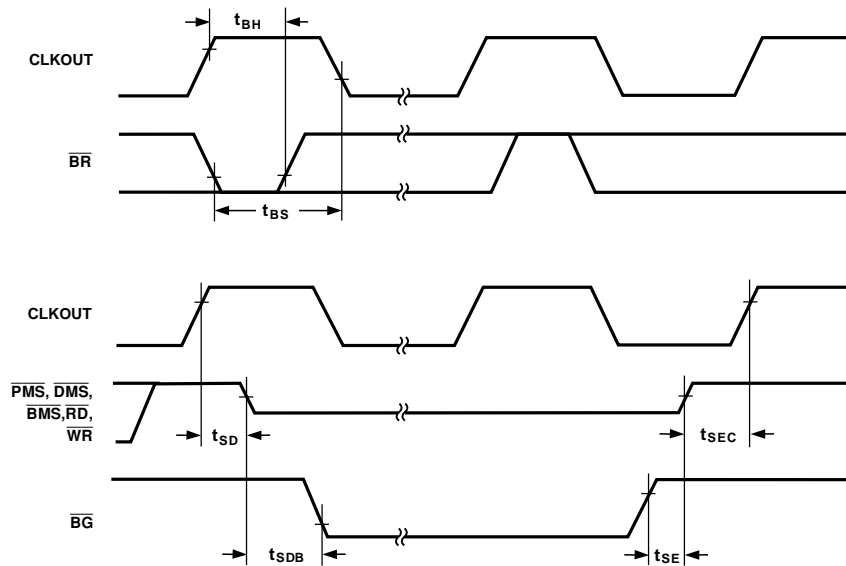

Figure 17. Bus Request-Bus Grant

ADSP-21msp58/59

Parameter	Min	Max	Unit
Memory Read			
Timing Requirement:			
t_{RDD}	\overline{RD} Low to Data Valid	$0.5t_{CK} - 11 + w$	ns
t_{AA}	A0-A13, \overline{PMS} , \overline{DMS} , \overline{BMS} to Data Valid	$0.75t_{CK} - 12 + w$	ns
t_{RDH}	Data Hold from \overline{RD} High	0	ns
Switching Characteristic:			
t_{RP}	\overline{RD} Pulse Width	$0.5t_{CK} - 5 + w$	ns
t_{CRD}	CLKOUT High to \overline{RD} Low	$0.25t_{CK} - 5$	ns
t_{ASR}	A0-A13, \overline{PMS} , \overline{DMS} , \overline{BMS} Setup before \overline{RD} Low	$0.25t_{CK} - 6$	ns
t_{RDA}	A0-A13, \overline{PMS} , \overline{DMS} , \overline{BMS} Hold after \overline{RD} Deasserted	$0.25t_{CK} - 3$	ns
t_{RWR}	\overline{RD} High to \overline{RD} or \overline{WR} Low	$0.5t_{CK} - 5$	ns

NOTE
 $w = \text{wait states} \times t_{CK}$.

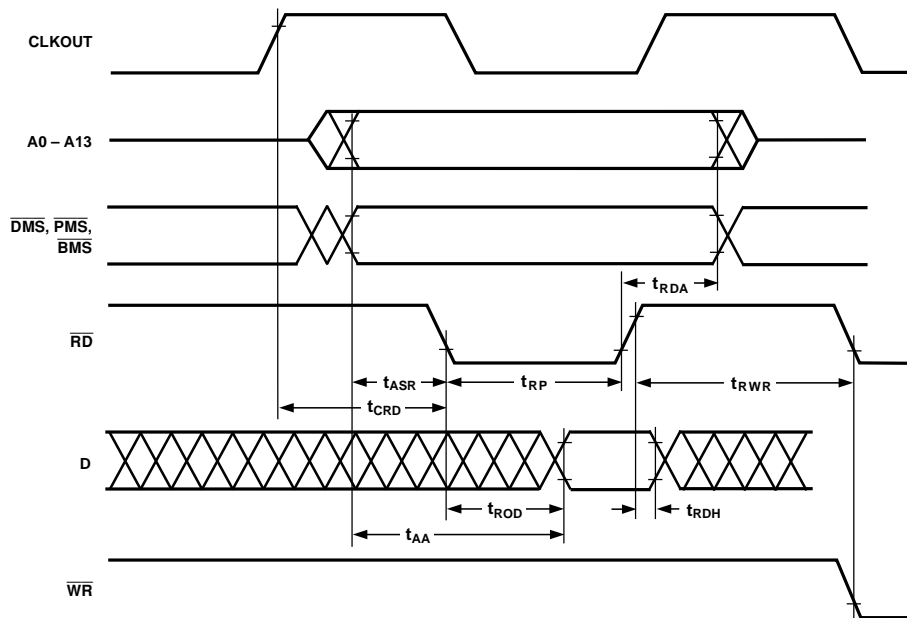

Figure 18. Memory Read

Parameter	Min	Max	Unit
Memory Write			
Switching Characteristic:			
t_{DW}	Data Setup before \overline{WR} High	$0.5t_{CK} - 7 + w$	ns
t_{DH}	Data Hold after \overline{WR} High	$0.25t_{CK} - 2$	ns
t_{WP}	\overline{WR} Pulse Width	$0.5t_{CK} - 5 + w$	ns
t_{WDE}	\overline{WR} Low to Data Enabled	0	ns
t_{ASW}	A0-A13, \overline{DMS} , \overline{PMS} Setup before \overline{WR} Low	$0.25t_{CK} - 6$	ns
t_{DDR}	Data Disable before \overline{WR} or \overline{RD} Low	$0.25t_{CK} - 6$	ns
t_{CWR}	CLKOUT High to \overline{WR} Low	$0.25t_{CK} - 5$	ns
t_{AW}	A0-A13, \overline{DMS} , \overline{PMS} , Setup before \overline{WR} Deasserted	$0.75t_{CK} - 9 + w$	ns
t_{WRA}	A0-A13, \overline{DMS} , \overline{PMS} Hold after \overline{WR} Deasserted	$0.25t_{CK} - 3$	ns
t_{WWR}	\overline{WR} High to \overline{RD} or \overline{WR} Low	$0.5t_{CK} - 5$	ns

NOTE
 $w = \text{wait states} \times t_{CK}$.

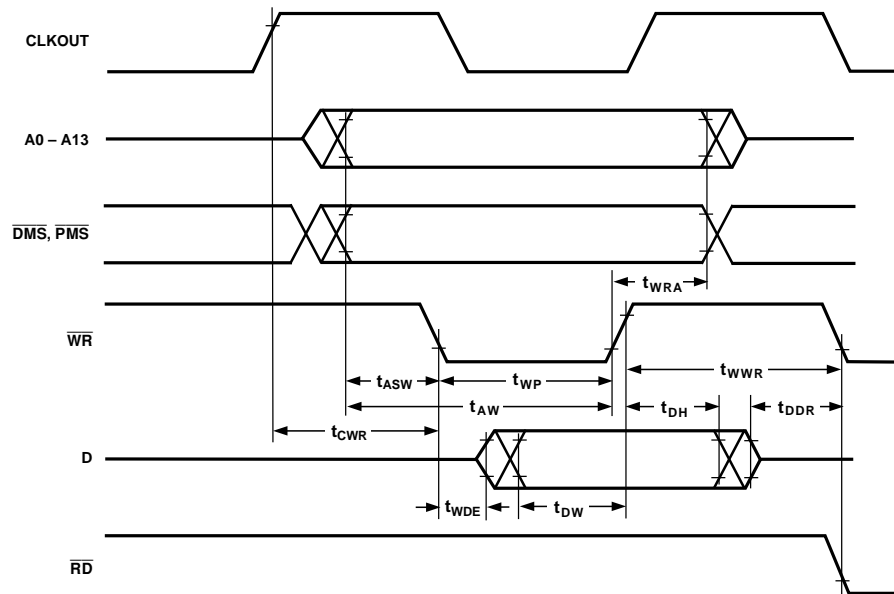

Figure 19. Memory Write

ADSP-21msp58/59

Parameter		Min	Max	Unit
Serial Ports				
Timing Requirement:				
t_{SCK}	SCLK Period	50		ns
t_{SCS}	DR/TFS/RFS Setup before SCLK Low	4		ns
t_{SCH}	DR/TFS/RFS Hold after SCLK Low	7		ns
t_{SCP}	SCLK _{in} Width	20		ns
Switching Characteristic:				
t_{CC}	CLKOUT High to SCLK _{out}	$0.25t_{CK}$	$0.25t_{CK} + 10$	ns
t_{SCDE}	SCLK High to DT Enable	0		ns
t_{SCDV}	SCLK High to DT Valid		15	ns
t_{RH}	TFS/RFS _{out} Hold after SCLK High	0		ns
t_{RD}	TFS/RFS _{out} Delay from SCLK High		15	ns </td
t_{SCDH}	DT Hold after SCLK High	0		ns
t_{TDE}	TFS(Alt) to DT Enable	0		ns
t_{TDV}	TFS(Alt) to DT Valid			ns
t_{SCDD}	SCLK High to DT Disable		14	ns
t_{RDV}	RFS (Multichannel, Frame Delay Zero) to DT Valid		15	ns

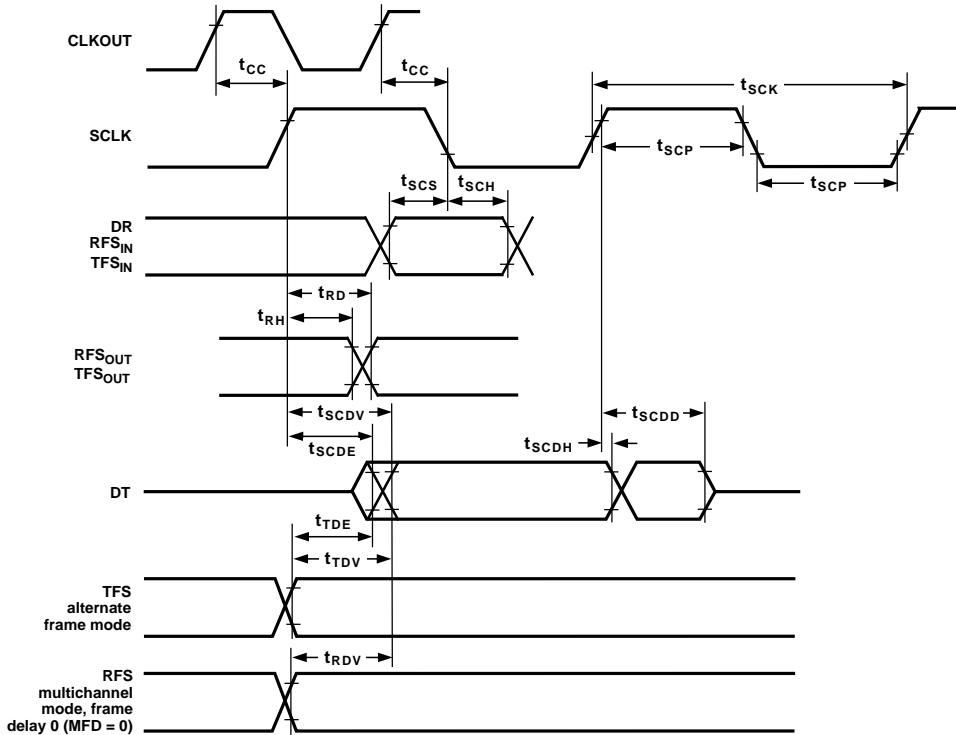

Figure 20. Serial Ports

Parameter	Min	Max	Unit
Host Interface Port			
Separate Data and Address (HMD1 = 0)			
Read Strobe and Write Strobe (HMD0 = 0)			
Timing Requirement:			
t_{HSU}	HA2-0 Setup before Start of Write or Read ^{1, 2}	5	ns
t_{HDSU}	Data Setup before End of Write ³	5	ns
t_{HWDH}	Data Hold after End of Write ³	3	ns
t_{HH}	HA2-0 Hold after End of Write or Read ^{3, 4}	3	ns
t_{HRWP}	Read or Write Pulse Width ⁵	20	ns
Switching Characteristic:			
t_{HSHK}	\overline{HACK} Low after Start of Write or Read ^{1, 2}	0	15
t_{HKH}	\overline{HACK} Hold after End of Write or Read ^{3, 4}	0	15
t_{HDE}	Data Enabled after Start of Read ²	0	ns
t_{HDD}	Data Valid after Start of Read ²	0	18
t_{HRDH}	Data Hold after End of Read ⁴	0	ns
t_{HRDD}	Data Disabled after End of Read ⁴	0	7

NOTES

¹Start of Write = \overline{HWR} Low and \overline{HSEL} Low.

²Start of Read = \overline{HRD} Low and \overline{HSEL} Low.

³End of Write = \overline{HWR} High or \overline{HSEL} High.

⁴End of Read = \overline{HRD} High or \overline{HSEL} High.

⁵Read Pulse Width = \overline{HRD} Low and \overline{HSEL} Low, Write Pulse Width = \overline{HWR} Low and \overline{HSEL} Low.

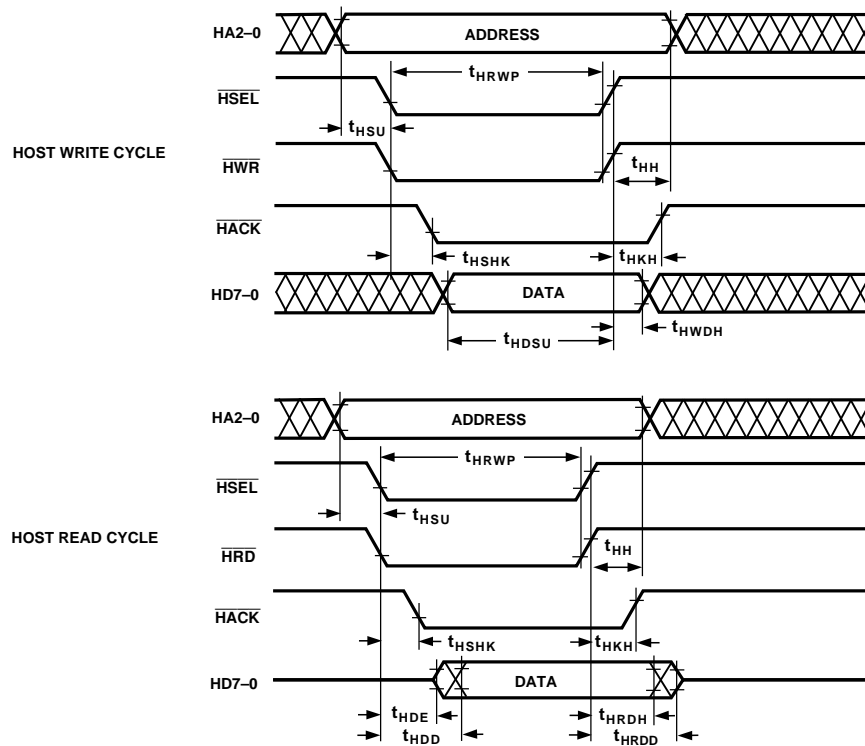

Figure 21. Host Interface Port (HMD1 = 0, HMD0 = 0)

ADSP-21msp58/59

Parameter		Min	Max	Unit
Host Interface Port				
Separate Data and Address (HMD1 = 0)				
Read Strobe and Write Strobe (HMD0 = 1)				
Timing Requirement:				
t_{HSU}	HA2-0, HRW Setup before Start of Write or Read ¹	5		ns
t_{HDSU}	Data Setup before End of Write ²	5		ns
t_{HWDH}	Data Hold after End of Write ²	3		ns
t_{HH}	HA2-0, HRW Hold after End of Write or Read ²	3		ns
t_{HRWP}	Read or Write Pulse Width ³	20		ns
Switching Characteristic:				
t_{HSHK}	\overline{HACK} Low after Start of Write or Read ¹	0	15	ns
t_{HKH}	\overline{HACK} Hold after End of Write or Read ²	0	15	ns
t_{HDE}	Data Enabled after Start of Read ¹	0		ns
t_{HDD}	Data Valid after Start of Read ¹		18	ns
t_{HRDH}	Data Hold after End of Read ²	0		ns
t_{HRDD}	Data Disabled after End of Read ²		7	ns

NOTES

¹Start of Write or Read = \overline{HDS} Low and \overline{HSEL} Low.

²End of Write or Read = \overline{HDS} High and \overline{HSEL} High.

³Read or Write Pulse Width = \overline{HDS} Low and \overline{HSEL} Low.

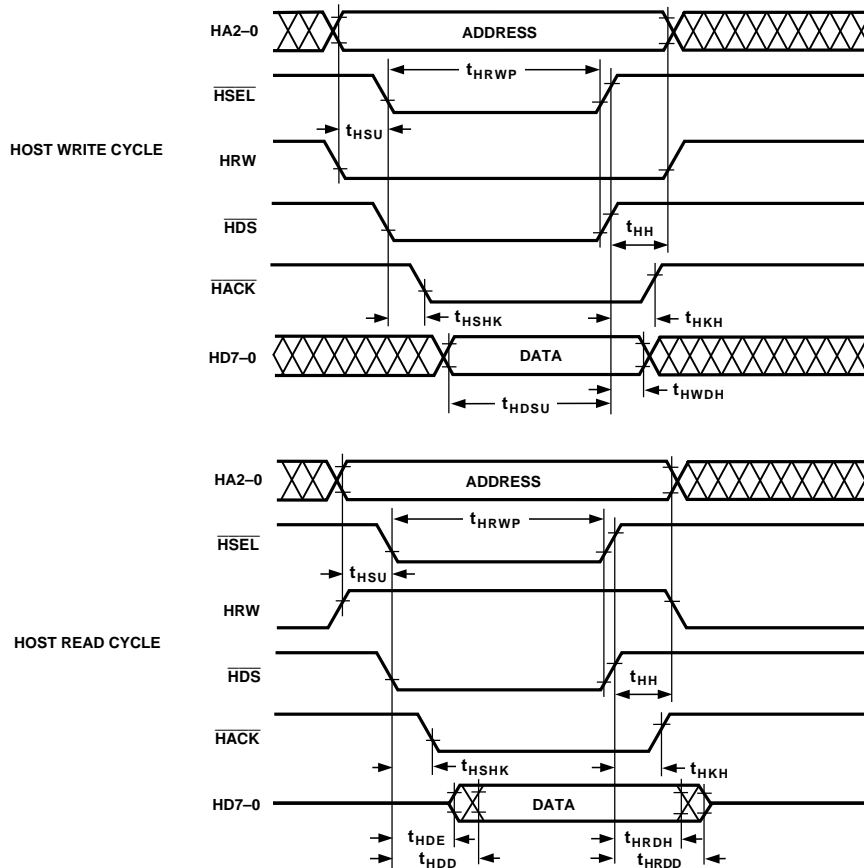

Figure 22. Host Interface Port (HMD1 = 0, HMD0 = 1)

Parameter	Min	Max	Unit
Host Interface Port			
Multiplexed Data and Address (HMD1 = 1)			
Read Strobe and Write Strobe (HMD0 = 0)			
Timing Requirement:			
t_{HALP}	ALE Pulse Width	10	ns
t_{HASU}	HAD15-0 Address Setup, before ALE Low	5	ns
t_{HAH}	HAD15-0 Address Hold after ALE Low	2	ns
t_{HALS}	Start of Write or Read after ALE Low ^{1, 2}	10	ns
t_{HDSU}	HAD15-0 Data Setup before End of Write ³	5	ns
t_{HWDH}	HAD15-0 Data Hold after End of Write ³	3	ns
t_{HRWP}	Read or Write Pulse Width ⁵	20	ns
Switching Characteristic:			
t_{HSHK}	\overline{HACK} Low after Start of Write or Read ^{1, 2}	0	15
t_{HKH}	\overline{HACK} Hold after End of Write or Read ^{3, 4}	0	15
t_{HDE}	HAD15-0 Data Enabled after Start of Read ²	0	18
t_{HDD}	HAD15-0 Data Valid after Start of Read ²	0	18
t_{HRDH}	HAD15-0 Data Hold after End of Read	0	18
t_{HRDD}	HAD15-0 Data Disabled after End of Read ⁴	0	7

NOTES

¹Start of Write = \overline{HWR} Low and \overline{HSEL} Low.

²Start of Read = \overline{HRD} Low and \overline{HSEL} Low.

³End of Write = \overline{HWR} High or \overline{HSEL} High.

⁴End of Read = \overline{HRD} High or \overline{HSEL} High.

⁵Read Pulse Width = \overline{HRD} Low and \overline{HSEL} Low, Write Pulse Width = \overline{HWR} Low and \overline{HSEL} Low.

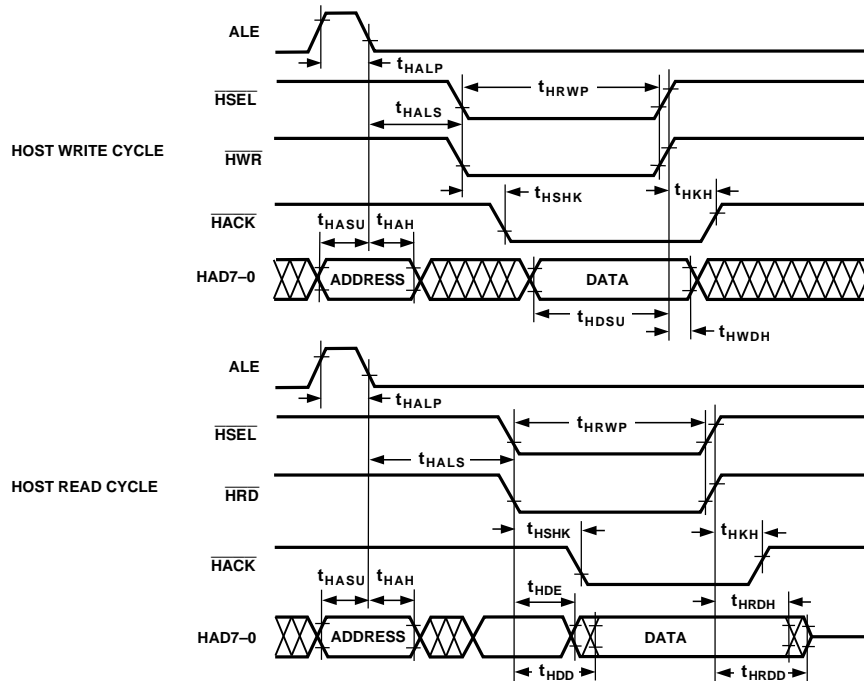

Figure 23. Host Interface Port (HMD1 = 1, HMD0 = 0)

ADSP-21msp58/59

Parameter	Min	Max	Unit
Host Interface Port			
Multiplexed Data and Address (HMD1 = 1)			
Read Strobe and Write Strobe (HMD0 = 1)			
Timing Requirement:			
t_{HALP}	ALE Pulse Width	10	ns
t_{HASU}	HAD15-0 Address Setup before ALE Low	5	ns
t_{HAH}	HAD15-0 Address Hold after ALE Low	2	ns
t_{HALS}	Start of Write or Read after ALE Low ¹	10	ns
t_{HSU}	HRW Setup before Start of Write or Read ¹	5	ns
t_{HDSU}	HAD15-0 Data Setup before End of Write ²	5	ns
t_{HWDH}	HAD15-0 Data Hold after End of Write ²	3	ns
t_{HH}	HRW Hold after End of Write or Read ²	3	ns
t_{HRWP}	Read or Write Pulse Width ³	20	ns
Switching Characteristic:			
t_{HSHK}	\overline{HACK} Low after Start of Write or Read ¹	0	15
t_{HKKH}	\overline{HACK} Hold after End of Write or Read ²	0	15
t_{HDE}	HAD15-0 Data Enabled after Start of Read ¹	0	
t_{HDD}	HAD15-0 Data Valid after Start of Read ¹		18
t_{HRDH}	HAD15-0 Data Hold after End of Read ²	0	ns
t_{HRDD}	HAD15-0 Data Disabled after End of Read ²		7

NOTES

¹Start of Write or Read = \overline{HDS} Low and \overline{HSEL} Low.

²End of Write or Read = \overline{HDS} High and \overline{HSEL} High.

³Read or Write Pulse Width = \overline{HDS} Low and \overline{HSEL} Low.

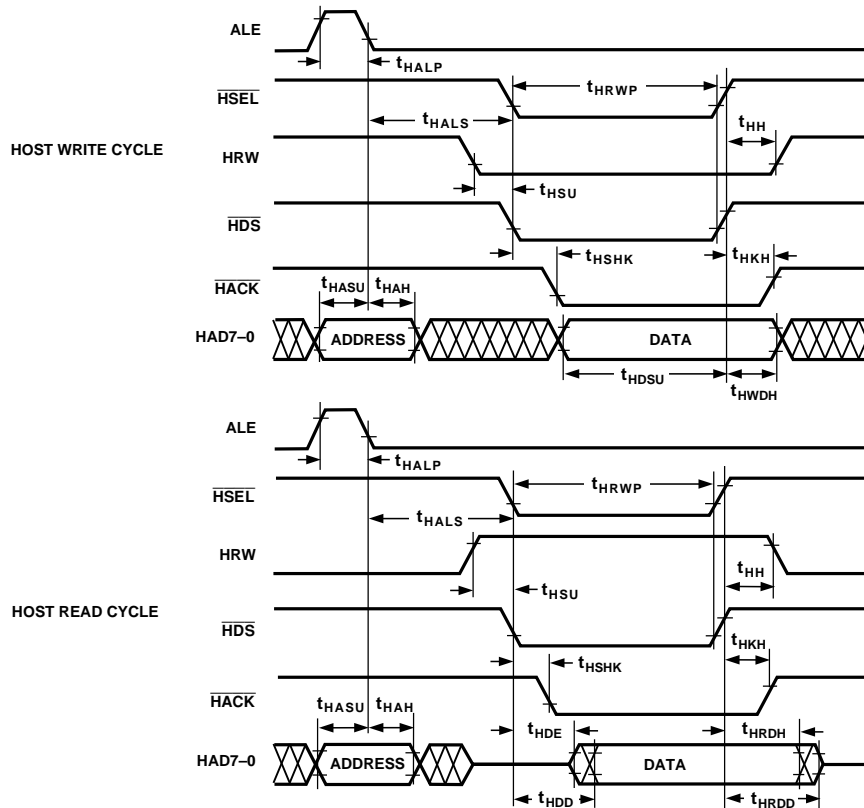

Figure 24. Host Interface Port (HMD1 = 1, HMD0 = 1)

ENVIRONMENTAL CONDITIONS

Ambient Temperature Rating:

$$T_{AMB} = T_{CASE} - (PD \times \theta_{CA})$$

T_{CASE} = Case Temperature in °C

PD = Power Dissipation in W

θ_{CA} = Thermal Resistance (Case-to-Ambient)

θ_{JA} = Thermal Resistance (Junction-to-Ambient)

θ_{JC} = Thermal Resistance (Junction-to-Case)

Package	θ_{JA}	θ_{JC}	θ_{CA}
TQFP	50°C/W	2°C/W	48°C/W

POWER DISSIPATION

To determine total power dissipation in a specific application, the following equation should be applied for each output:

$$C \times V_{DD}^2 \times f$$

C = load capacitance, f = output switching frequency.

Example:

In an application where external data memory is used and no other outputs are active, power dissipation is calculated as follows:

Assumptions:

- External data memory is accessed every cycle with 50% of the address pins switching.
- External data memory writes occur every other cycle with 50% of the data pins switching.
- Each address and data pin has a 10 pF total load at the pin.
- The application operates at $V_{DD} = 5.0$ V and $t_{CK} = 76.92$ ns.

$$\text{Total Power Dissipation} = P_{INT} + (C \times V_{DD}^2 \times f)$$

P_{INT} = internal power dissipation from Power vs. Frequency graph (Figure 25).

$(C \times V_{DD}^2 \times f)$ is calculated for each output:

	# of Pins	$\times C$	$\times V_{DD}^2$	$\times f$	
Address, \overline{DMS}	8	$\times 10$ pF	$\times 5^2$ V	$\times 26$ MHz	= 52 mW
Data Output, \overline{WR}	9	$\times 10$ pF	$\times 5^2$ V	$\times 13$ MHz	= 30 mW
RD	1	$\times 10$ pF	$\times 5^2$ V	$\times 13$ MHz	= 4 mW
CLKOUT	1	$\times 10$ pF	$\times 5^2$ V	$\times 26$ MHz	= 6 mW
					92 mW

Total power dissipation for this example is $P_{INT} + 92$ mW.

Typical Power Consumption

The typical power consumption can be calculated from the following data, taken at 5.0 V and +25°C. Dynamic V_{DD} data was taken while executing 80% type 1 multifunction instructions, on random data.

Parameter	Typ
I_{DD} Digital Supply Current (Idle, Codec Powered Up)	19 mA
I_{DD} Digital Supply Current (Idle)	13 mA
I_{DD} Digital Supply Current (Dynamic, Codec Powered Up)	83 mA
I_{DD} Digital Supply Current (Dynamic)	78 mA
I_{DD} Digital Supply Current (Powerdown)	10 μ A
I_{CC} Analog Supply Current (Dynamic)	15 mA

Analog Devices recommends that the ADSP-21msp58/59 is used with a 13 MHz input clock. Below this input clock

frequency, the codec performance changes and the performance specifications cannot be guaranteed. The codec filter characteristics, however, scale approximately linearly with frequency.

If the codec is disabled, then the processor can be used at any allowed input frequency. The power consumption of the ADSP-21msp58/59 at these frequencies is shown in Figure 25.

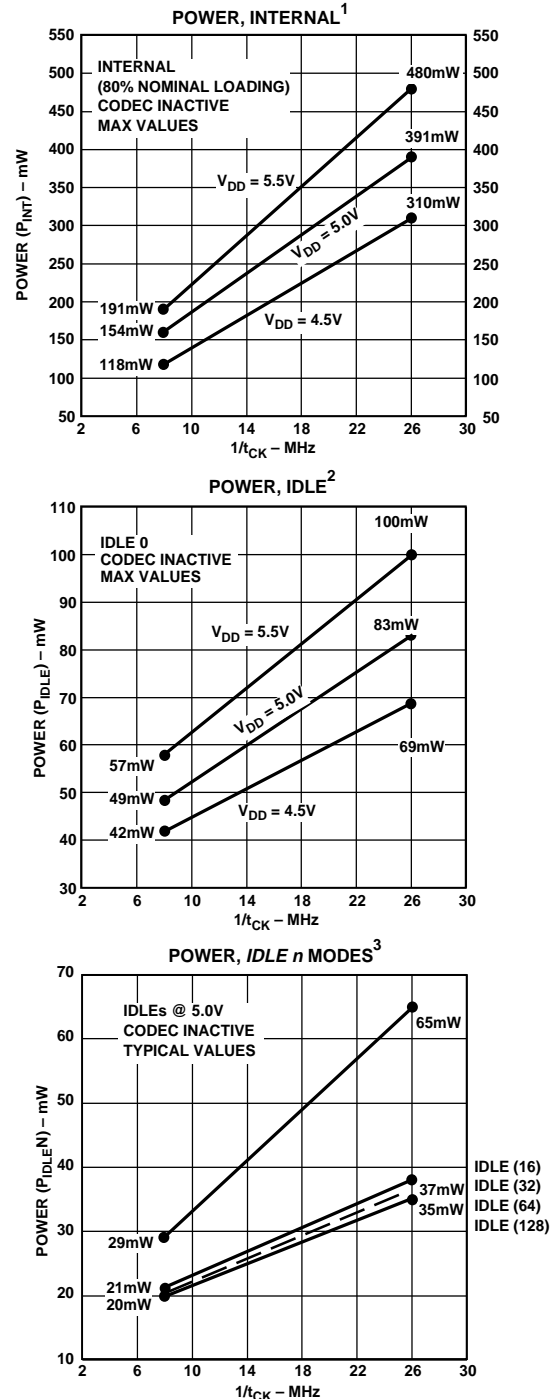

VALID FOR ALL TEMPERATURE GRADES.

¹ POWER REFLECTS DEVICE OPERATING WITH NO OUTPUT LOADS.

² IDLE REFERS TO ADSP-21msp58/59 STATE OF OPERATION DURING EXECUTION OF IDLE INSTRUCTION. DEASSERTED PINS ARE DRIVEN TO EITHER V_{DD} OR GND.

³ POWER REFLECTS DEVICE OPERATING WITH CLKOUT DISABLED.

³ TYPICAL POWER DISSIPATION AT 5.0V V_{DD} DURING EXECUTION OF IDLE n INSTRUCTION (CLOCK FREQUENCY REDUCTION). POWER REFLECTS DEVICE OPERATING WITH CLKOUT DISABLED.

Figure 25. Power vs. Internal Processor Frequency

ADSP-21msp58/59

CAPACITIVE LOADING

Figures 26 and 27 show the capacitive loading characteristics of the ADSP-21msp58/59.

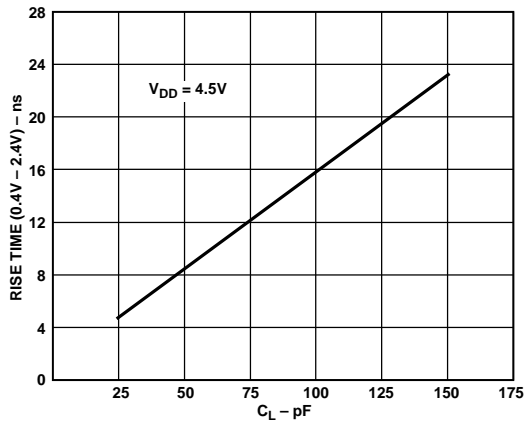

Figure 26. Typical Output Rise Time vs. Load Capacitance, C_L (at Maximum Ambient Operating Temperature)

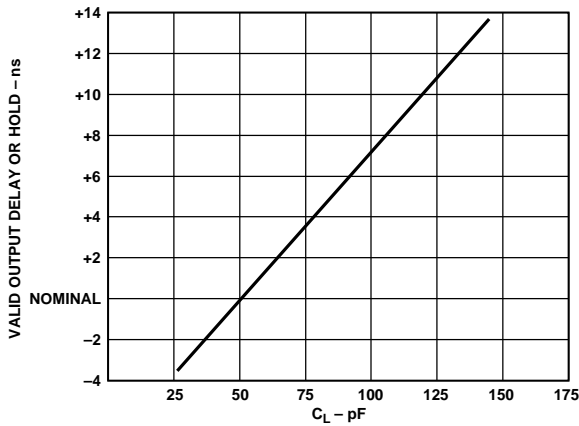

Figure 27. Typical Output Valid Delay or Hold vs. Load Capacitance, C_L (at Maximum Ambient Operating Temperature)

TEST CONDITIONS

Digital

Figure 28 shows the voltage reference levels and Figure 29 shows the equivalent device loading for the ac measurements.



Figure 28. Voltage Reference Levels for AC Measurements (Except Output Enable/Disable)

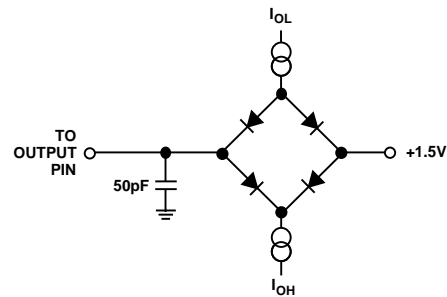

Figure 29. Equivalent Device Loading for AC Measurements (Including All Fixtures)

Analog

Figure 30 shows the analog test conditions.

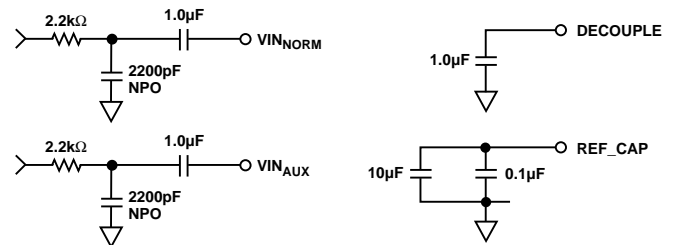

Figure 30. Analog Test Conditions

Output Disable Time

Output pins are considered to be disabled when they have stopped driving and started a transition from the measured output high or low voltage to a high impedance state. The output disable time (t_{DIS}) is the difference of $t_{MEASURED}$ and t_{DECAY} , as shown in the Output Enable/Disable diagram. The time is the interval from when a reference signal reaches a high or low voltage level to when the output voltages have changed by 0.5 V from the measured output high or low voltage. The decay time, t_{DECAY} , is dependent on the capacitive load, C_L , and the current load, i_L , on the output pin. It can be approximated by the following equation:

$$t_{DECAY} = \frac{C_L \cdot 0.5 V}{i_L}$$

from which

$$t_{DIS} = t_{MEASURED} - t_{DECAY}$$

is calculated. If multiple pins (such as the data bus) are disabled, the measurement value is that of the last pin to stop driving.

Output Enable Time

Output pins are considered to be enabled when they have made a transition from a high-impedance state to when they start driving. The output enable time (t_{ENA}) is the interval from when a reference signal reaches a high or low voltage level to when the output has reached a specified high or low trip point, as shown in the Output Enable/Disable diagram. If multiple pins (such as the data bus) are enabled, the measurement value is that of the first pin to start driving.

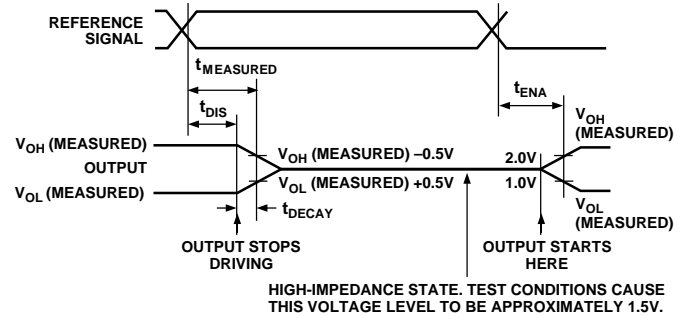
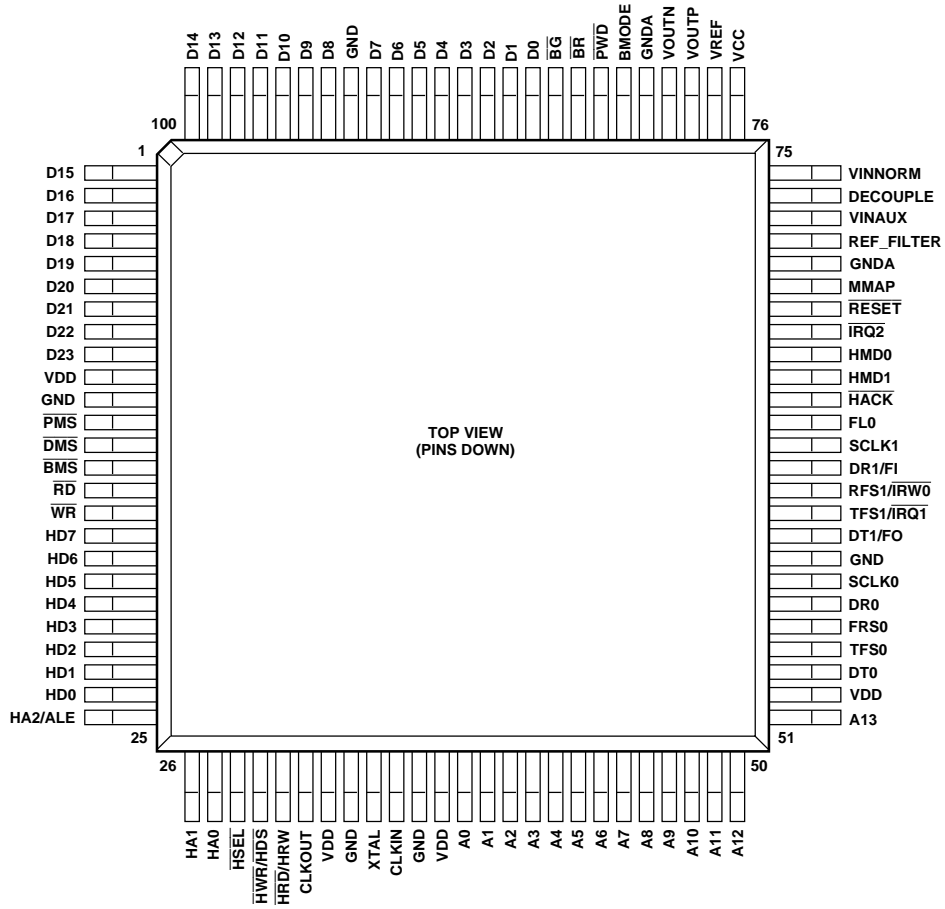

Figure 31. Output Enable/Disable

ADSP-21msp58/59

PIN CONFIGURATION 100-Lead Thin Plastic Quad Flatpack (TQFP)



100-Lead Thin Plastic Quad Flatpack (TQFP) Pinout

TQFP Number	Pin Name	TQFP Number	Pin Name	TQFP Number	Pin Name	TQFP Number	Pin Name
1	D15	26	HA1	51	A13	76	VCC
2	D16	27	HA0	52	VDD	77	VREF
3	D17	28	HSEL	53	DT0	78	VOUTP
4	D18	29	HWR/HDS	54	TFS0	79	VOUTN
5	D19	30	HRD/HRW	55	RFS0	80	GND
6	D20	31	CLKOUT	56	DR0	81	BMODE
7	D21	32	VDD	57	SCLK0	82	PWD
8	D22	33	GND	58	GND	83	BR
9	D23	34	XTAL	59	DT1/FO	84	BG
10	VDD	35	CLKIN	60	TFS1/IRQ1	85	D0
11	GND	36	GND	61	RFS1/IRQ0	86	D1
12	PMS	37	VDD	62	DR1/FI	87	D2
13	DMS	38	A0	63	SCLK1	88	D3
14	BMS	39	A1	64	FL0	89	D4
15	RD	40	A2	65	HACK	90	D5
16	WR	41	A3	66	HMD1	91	D6
17	HD7	42	A4	67	HMD0	92	D7
18	HD6	43	A5	68	IRQ2	93	GND
19	HD5	44	A6	69	RESET	94	D8
20	HD4	45	A7	70	MMAP	95	D9
21	HD3	46	A8	71	GNDA	96	D10
22	HD2	47	A9	72	REF_FILTER	97	D11
23	HD1	48	A10	73	VINAUX	98	D12
24	HD0	49	A11	74	DECOUPLE	99	D13
25	HA2/ALE	50	A12	75	VINNORM	100	D14

OUTLINE DIMENSIONS

Dimensions shown in millimeters and (inches)

100-Lead Metric Thin Plastic Quad Flat Pack (TQFP)

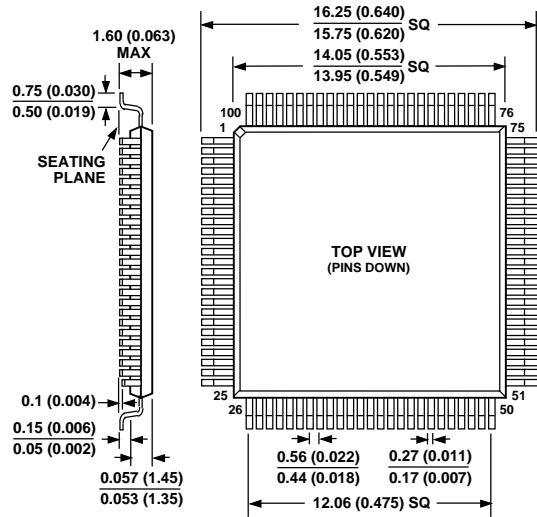

ORDERING GUIDE*

Part Number	Ambient Temperature Range	Instruction Rate (MIPS)	Package Description	Package Option
ADSP-21msp58BST-104	-40°C to +85°C	26	100-Lead TQFP	ST-100

*Refer to the section titled "Ordering Procedure for ADSP-21msp59 ROM Processors" for information about ordering ROM coded parts.

This datasheet has been downloaded from:

www.DatasheetCatalog.com

Datasheets for electronic components.



LittleDiode supplies new, hard to find or obsolete electronic components and semiconductors all over the world.

With over two million different components listed you are sure to find the part you need.

Feel free to visit us today at our online store:

LittleDiode.com

Looking forward to providing you with the best possible service.