

FEATURES

- 220 MHz, 24-Bit (30-Bit Gamma Corrected) True Color
- Triple 10-Bit "Gamma Correcting" D/A Converters
- Triple 256 × 10 (256 × 30) Color Palette RAM
- On-Chip Clock Control Circuit
- Palette Priority Select Registers
- RS-343A/RS-170 Compatible Analog Outputs
- TTL Compatible Digital Inputs
- Standard MPU I/O Interface
 - 10-Bit Parallel Structure
 - 8+2 Byte Structure
- Programmable Pixel Port: 24-Bit, 15-Bit and 8-Bit (Pseudo)

Pixel Data Serializer

- Multiplexed Pixel Input Ports; 1:1, 2:1, 4:1
- +5 V CMOS Monolithic Construction
- 160-Lead Plastic Quad Flatpack (QFP)
- Thermally Enhanced to Achieve $\theta_{JC} < 1.0^{\circ}\text{C/W}$

MODES OF OPERATION

24-Bit True Color (30-Bit Gamma Corrected)

- @ 220 MHz
- @ 170 MHz
- @ 135 MHz
- @ 110 MHz

@ 85 MHz

- 8-Bit Pseudo Color
- 15-Bit True Color

APPLICATIONS

- High Resolution, True Color Graphics
- Professional Color Prepress Imaging

GENERAL DESCRIPTION

The ADV7150 (ADV[®]) is a complete analog output, Video RAM-DAC on a single CMOS monolithic chip. The part is specifically designed for use in high performance, color graphics workstations. The ADV7150 integrates a number of graphic functions onto one device allowing 24-bit direct True-Color operation at the maximum screen update rate of 220 MHz. The ADV7150 implements 30-bit True Color in 24-bit frame buffer designs. The part also supports other modes, including 15-bit True Color and 8-bit Pseudo or Indexed Color. Either the Red, Green or Blue input pixel ports can be used for Pseudo Color.

(Continued on page 12)

ADV is a registered trademark of Analog Devices, Inc.

FUNCTIONAL BLOCK DIAGRAM

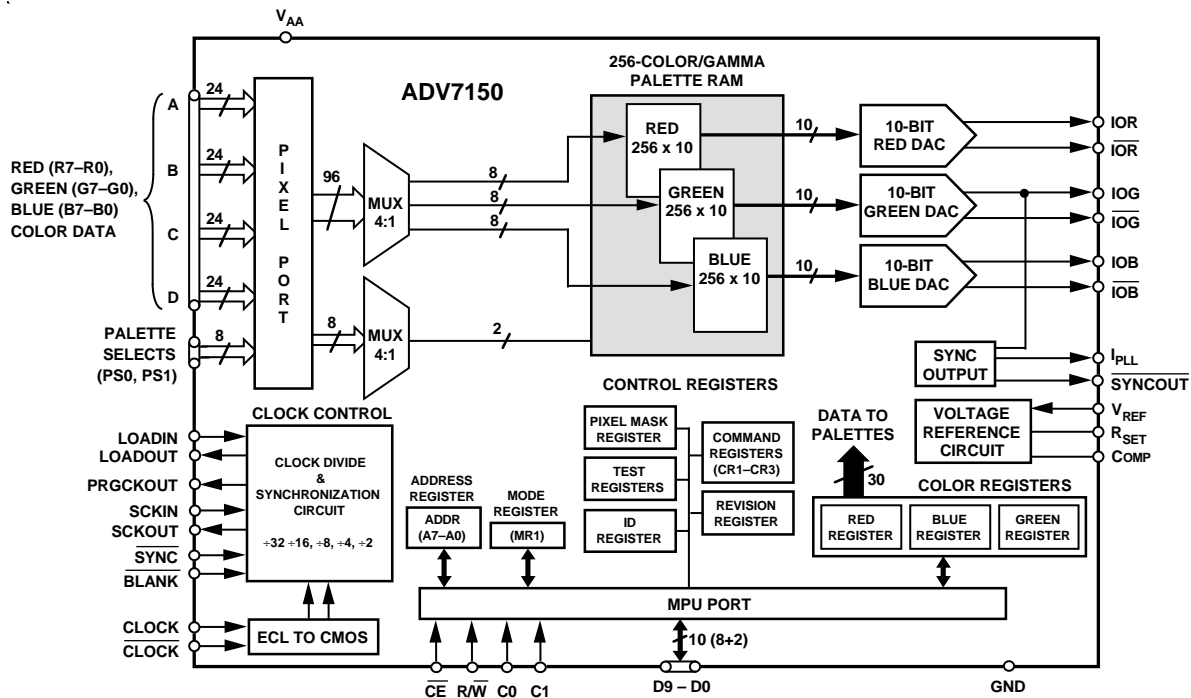

REV. A

Information furnished by Analog Devices is believed to be accurate and reliable. However, no responsibility is assumed by Analog Devices for its use, nor for any infringements of patents or other rights of third parties which may result from its use. No license is granted by implication or otherwise under any patent or patent rights of Analog Devices.

© Analog Devices, Inc., 1996

One Technology Way, P.O. Box 9106, Norwood, MA 02062-9106, U.S.A.
Tel: 617/329-4700 Fax: 617/326-8703

ADV7150—SPECIFICATIONS

($V_{AA}^1 = +5\text{ V}$; $V_{REF} = +1.235\text{ V}$; $R_{SET} = 280\ \Omega$. IOR, IOG, IOB ($R_L = 37.5\ \Omega$, $C_L = 10\text{ pF}$); IOR, IOG, IOB = GND. All specifications T_{MIN} to T_{MAX}^2 unless otherwise noted.)

Parameter	All Versions	Unit	Test Conditions/Comments
STATIC PERFORMANCE			
Resolution (Each DAC)	10	Bits	Guaranteed Monotonic
Accuracy (Each DAC)			
Integral Nonlinearity	± 1	LSB max	
Differential Nonlinearity	± 1	LSB max	
Gray Scale Error	± 5	% Gray Scale max	
Coding		Binary	
DIGITAL INPUTS (Excluding CLOCK, $\overline{\text{CLOCK}}$)			
Input High Voltage, V_{INH}	2	V min	$V_{IN} = 0.4\text{ V or }2.4\text{ V}$
Input Low Voltage, V_{INL}	0.8	V max	
Input Current, I_{IN}	± 10	$\mu\text{A max}$	
Input Capacitance, C_{IN}	10	pF max	
CLOCK INPUTS (CLOCK, $\overline{\text{CLOCK}}$)			
Input High Voltage, V_{INH}	$V_{AA} - 1.0$	V min	$V_{IN} = 0.4\text{ V or }2.4\text{ V}$
Input Low Voltage, V_{INL}	$V_{AA} - 1.6$	V max	
Input Current, I_{IN}	± 10	$\mu\text{A max}$	
Input Capacitance, C_{IN}	10	pF typ	
DIGITAL OUTPUT			
Output High Voltage, V_{OH}	2.4	V min	$I_{SOURCE} = 400\ \mu\text{A}$ $I_{SINK} = 3.2\text{ mA}$
Output Low Voltage, V_{OL}	0.4	V max	
Floating-State Leakage Current	20	$\mu\text{A max}$	
Floating-State Output Capacitance	20	pF typ	
ANALOG OUTPUTS			
Gray Scale Current Range	15/22	mA min/max	Typically 19.05 mA Typically 17.62 mA Typically 1.44 mA Typically 5 μA Typically 7.62 mA Typically 5 μA Typically 1% $I_{OUT} = 0\text{ mA}$
Output Current			
White Level Relative to Blank	17.69/20.40	mA min/max	
White Level Relative to Black	16.74/18.50	mA min/max	
Black Level Relative to Blank	0.95/1.90	mA min/max	
Blank Level on IOR, IOB	0/50	$\mu\text{A min/max}$	
Blank Level on IOG	6.29/8.96	mA min/max	
Sync Level on IOG	0/50	$\mu\text{A min/max}$	
LSB Size	17.22	$\mu\text{A typ}$	
DAC-to-DAC Matching	3	% max	
Output Compliance, V_{OC}	0/+1.4	V min/V max	
Output Impedance, R_{OUT}	100	k Ω typ	
Output Capacitance, C_{OUT}	30	pF max	
VOLTAGE REFERENCE			
Voltage Reference Range, V_{REF}	1.14/1.26	V min/V max	$V_{REF} = 1.235\text{ V for Specified Performance}$
Input Current, I_{VREF}	+5	$\mu\text{A typ}$	
POWER REQUIREMENTS			
V_{AA}	5	V nom	220 MHz Parts 170 MHz Parts 135 MHz Parts 110 MHz Parts 85 MHz Parts Typically 0.12%/%; COMP = 0.1 μF
I_{AA}^3	400	mA max	
I_{AA}^3	370	mA max	
I_{AA}	350	mA max	
I_{AA}	330	mA max	
I_{AA}	315	mA max	
Power Supply Rejection Ratio	0.5	%/% max	
DYNAMIC PERFORMANCE			
Clock and Data Feedthrough ^{4, 5}	-30	dB typ	
Glitch Impulse	50	pV secs typ	
DAC-to-DAC Crosstalk ⁶	-23	dB typ	

NOTES

¹ $\pm 5\%$ for all versions.

²Temperature range (T_{MIN} to T_{MAX}): 0°C to $+70^\circ\text{C}$; T_J (Silicon Junction Temperature) $\leq 100^\circ\text{C}$.

³Pixel Port is continuously clocked with data corresponding to a linear ramp. $T_J = 100^\circ\text{C}$.

⁴Clock and data feedthrough is a function of the amount of overshoot and undershoot on the digital inputs. Glitch impulse includes clock and data feedthrough.

⁵TTL input values are 0 to 3 volts, with input rise/fall times $\leq 3\text{ ns}$, measured the 10% and 90% points. Timing reference points at 50% for inputs and outputs.

⁶DAC-to-DAC crosstalk is measured by holding one DAC high while the other two are making low-to-high and high-to-low transitions.

Specifications subject to change without notice.

TIMING CHARACTERISTICS¹ ($V_{AA} = +5\text{ V}$; $V_{REF} = +1.235\text{ V}$; $R_{SET} = 280\ \Omega$. IOR, IOG, IOB ($R_L = 37.5\ \Omega$, $C_L = 10\text{ pF}$); IOR, IOG, IOB = GND. All specifications T_{MIN} to T_{MAX} ³ unless otherwise noted.)

CLOCK CONTROL AND PIXEL PORT⁴

Parameter	220 MHz Version	170 MHz Version	135 MHz Version	110 MHz Version	85 MHz Version	Units	Conditions/Comments
f_{CLOCK}	220	170	135	110	85	MHz max	Pixel CLOCK Rate
t_1	4.55	5.88	7.4	9.1	11.77	ns min	Pixel CLOCK Cycle Time
t_2	2	2.5	3.2	4	4	ns min	Pixel CLOCK High Time
t_3	2	2.5	3	4	4	ns min	Pixel CLOCK Low Time
t_4	10	10	10	10	10	ns max	Pixel CLOCK to LOADOUT Delay
f_{LOADIN}							LOADIN Clocking Rate
1:1 Multiplexing	110	110	110	110	85	MHz max	
2:1 Multiplexing	110	85	67.5	55	42.5	MHz max	
4:1 Multiplexing	55	42.5	33.75	27.5	21.25	MHz max	
t_5							LOADIN Cycle Time
1:1 Multiplexing	9.1	9.1	9.1	9.1	9.1	ns min	
2:1 Multiplexing	9.1	11.76	14.8	18.18	23.53	ns min	
4:1 Multiplexing	18.18	23.53	29.63	36.36	47.1	ns min	
t_6							LOADIN High Time
1:1 Multiplexing	4	4	4	4	4	ns min	
2:1 Multiplexing	4	5	6	8	9	ns min	
4:1 Multiplexing	8	9	12	15	18	ns min	
t_7							LOADIN Low Time
1:1 Multiplexing	4	4	4	4	4	ns min	
2:1 Multiplexing	4	5	6	8	9	ns min	
4:1 Multiplexing	8	9	12	15	18	ns min	
t_8	0	0	0	0	0	ns min	Pixel Data Setup Time
t_9	5	5	5	5	5	ns min	Pixel Data Hold Time
t_{10}	0	0	0	0	0	ns min	LOADOUT to LOADIN Delay
$\tau - t_{11}$ ⁵	$\tau - 5$	$\tau - 5$	$\tau - 5$	$\tau - 5$	$\tau - 5$	ns max	LOADOUT to LOADIN Delay
t_{PD} ⁶							Pipeline Delay
1:1 Multiplexing	5	5	5	5	5	CLOCKs	($1 \times \text{CLOCK} = t_1$)
2:1 Multiplexing	6	6	6	6	6	CLOCKs	
4:1 Multiplexing	8	8	8	8	8	CLOCKs	
t_{12}	10	10	10	10	10	ns max	Pixel CLOCK to PRGCKOUT Delay
t_{13}	5	5	5	5	5	ns max	SCKIN to SCKOUT Delay
t_{14}	5	5	5	5	5	ns min	BLANK to SCKIN Setup Time
t_{15}	1	1	1	1	1	ns min	BLANK to SCKIN Hold Time

ANALOG OUTPUTS⁷

Parameter	220 MHz Version	170 MHz Version	135 MHz Version	110 MHz Version	85 MHz Version	Units	Conditions/Comments
t_{16}	15	15	15	15	15	ns typ	Analog Output Delay
t_{17}	1	1	1	1	1	ns typ	Analog Output Rise/Fall Time
t_{18}	15	15	15	15	15	ns typ	Analog Output Transition Time
t_{SK}	2	2	2	2	2	ns max	Analog Output Skew (IOR, IOG, IOB)
	0	0	0	0	0	ns typ	

MPU PORTS^{8, 9}

Parameter	220 MHz Version	170 MHz Version	135 MHz Version	110 MHz Version	85 MHz Version	Units	Conditions/Comments
t_{19}	3	3	3	3	3	ns min	R/\overline{W} , C0, C1 to \overline{CE} Setup Time
t_{20}	10	10	10	10	10	ns min	R/\overline{W} , C0, C1 to \overline{CE} Hold Time
t_{21}	45	45	45	45	45	ns min	\overline{CE} Low Time
t_{22}	25	25	25	25	25	ns min	\overline{CE} High Time
t_{23} ⁸	5	5	5	5	5	ns min	\overline{CE} Asserted to Databus Driven
t_{24} ⁹	45	45	45	45	45	ns max	\overline{CE} Asserted to Data Valid
t_{25} ⁹	20	20	20	20	20	ns max	\overline{CE} Disabled to Databus Three-Stated
	5	5	5	5	5	ns min	
t_{26}	20	20	20	20	20	ns min	Write Data (D0-D9) Setup Time
t_{27}	5	5	5	5	5	ns min	Write Data (D0-D9) Hold Time

ADV7150

NOTES

¹TTL input values are 0 to 3 volts, with input rise/fall times ≤ 3 ns, measured between the 10% and 90% points. ECL inputs ($\overline{\text{CLOCK}}$, $\overline{\text{CLOCK}}$) are $V_{AA}-0.8$ V to $V_{AA}-1.8$ V, with input rise/fall times ≤ 2 ns, measured between the 10% and 90% points. Timing reference points at 50% for inputs and outputs. Analog output load ≤ 10 pF. Databus (D0-D9) loaded as shown in Figure 1. Digital output load for LOADOUT, PRGCKOUT, SCKOUT, I_{PLL} and SYNCOUT ≤ 30 pF.

² $\pm 5\%$ for all versions.

³Temperature range (T_{MIN} to T_{MAX}): 0°C to +70°C; T_J (Silicon Junction Temperature) $\leq 100^\circ\text{C}$.

⁴Pixel Port consists of the following inputs: Pixel Inputs: RED [A, B, C, D]; GREEN [A, B, C, D]; BLUE [A, B, C, D], Palette Selects: PS0 [A, B, C, D]; PS1 [A, B, C, D]; Pixel Controls: SYNC, BLANK; Clock Inputs: CLOCK, $\overline{\text{CLOCK}}$, LOADIN, SCKIN; Clock Outputs: LOADOUT, PRGCKOUT, SCKOUT.

⁵ τ is the LOADOUT Cycle Time and is a function of the Pixel CLOCK Rate and the Multiplexing Mode: 1:1 multiplexing; $\tau = \text{CLOCK} = t_1$ ns. 2:1 Multiplexing; $\tau = \text{CLOCK} \times 2 = 2 \times t_1$ ns. 4:1 Multiplexing; $\tau = \text{CLOCK} \times 4 = 4 \times t_1$ ns.

⁶These fixed values for Pipeline Delay are valid under conditions where t_{10} and $\tau - t_{11}$ are met. If either t_{10} or $\tau - t_{11}$ are not met, the part will operate but the Pipe line Delay is increased by 2 additional CLOCK cycles for 2:1 Mode and is increased by 4 additional CLOCK cycles for 4:1 Mode, after calibration is performed.

⁷Output delay measured from the 50% point of the rising edge of CLOCK to the 50% point of full-scale transition. Output rise/fall time measured between the 10% and 90% points of full-scale transition. Transition time measured from the 50% point of full-scale transition to the output remaining within 2% of the final output value (Transition time does not include clock and data feedthrough).

⁸ t_{23} and t_{24} are measured with the load circuit of Figure 1 and defined as the time required for an output to cross 0.4 V or 2.4 V.

⁹ t_{25} is derived from the measured time taken by the data outputs to change by 0.5 V when loaded with the circuit of Figure 1. The measured number is then extrapolated back to remove the effects of charging the 100 pF capacitor. This means that the time, t_{25} , quoted in the Timing Characteristics is the true value for the device and as such is independent of external databus loading capacitances.

Specifications subject to change without notice.

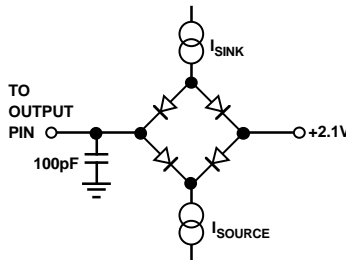

Figure 1. Load Circuit for Databus Access and Relinquish Times

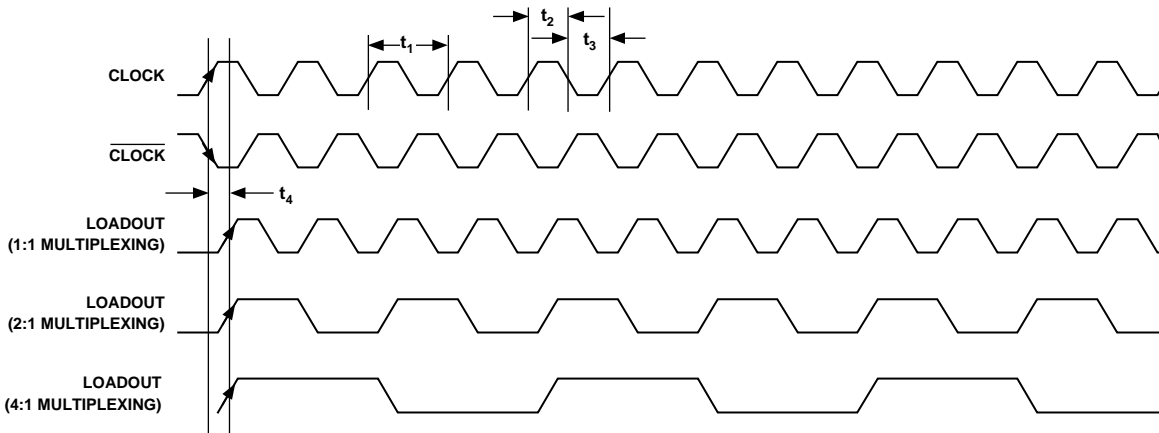
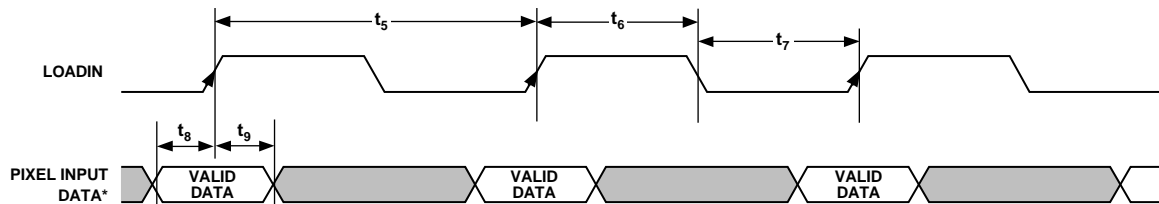

Figure 2. LOADOUT vs. Pixel Clock Input (CLOCK , $\overline{\text{CLOCK}}$)



*INCLUDES PIXEL DATA (R0-R7, G0-G7, B0-B7); PALETTE SELECT INPUTS (PS0-PS1); BLANK; SYNC

Figure 3. LOADIN vs. Pixel Input Data

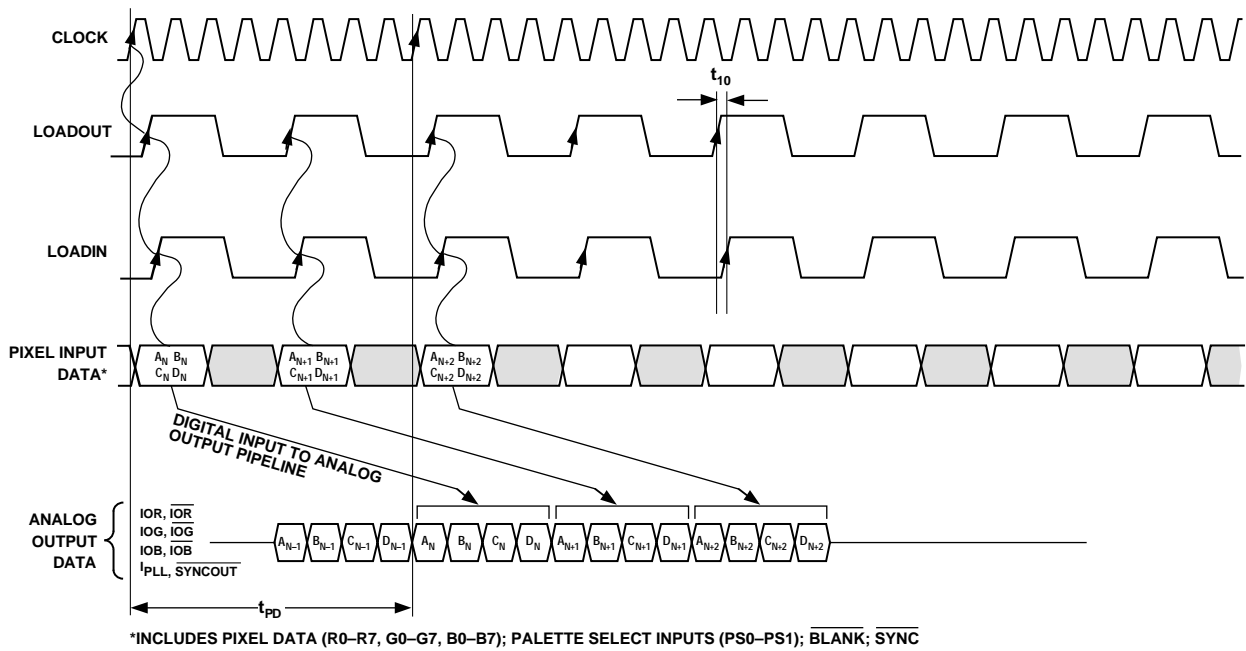

Figure 4. Pixel Input to Analog Output Pipeline with Minimum LOADOUT to LOADIN Delay (4:1 Multiplex Mode)

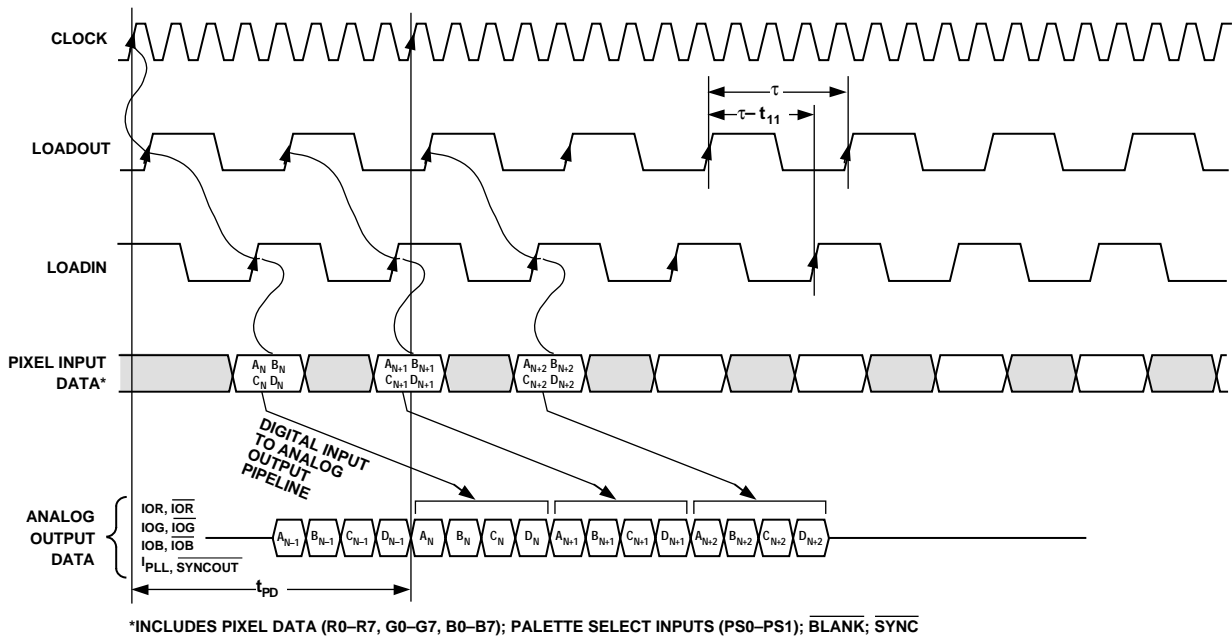

Figure 5. Pixel Input to Analog Output Pipeline with Maximum LOADOUT to LOADIN Delay (4:1 Multiplex Mode)

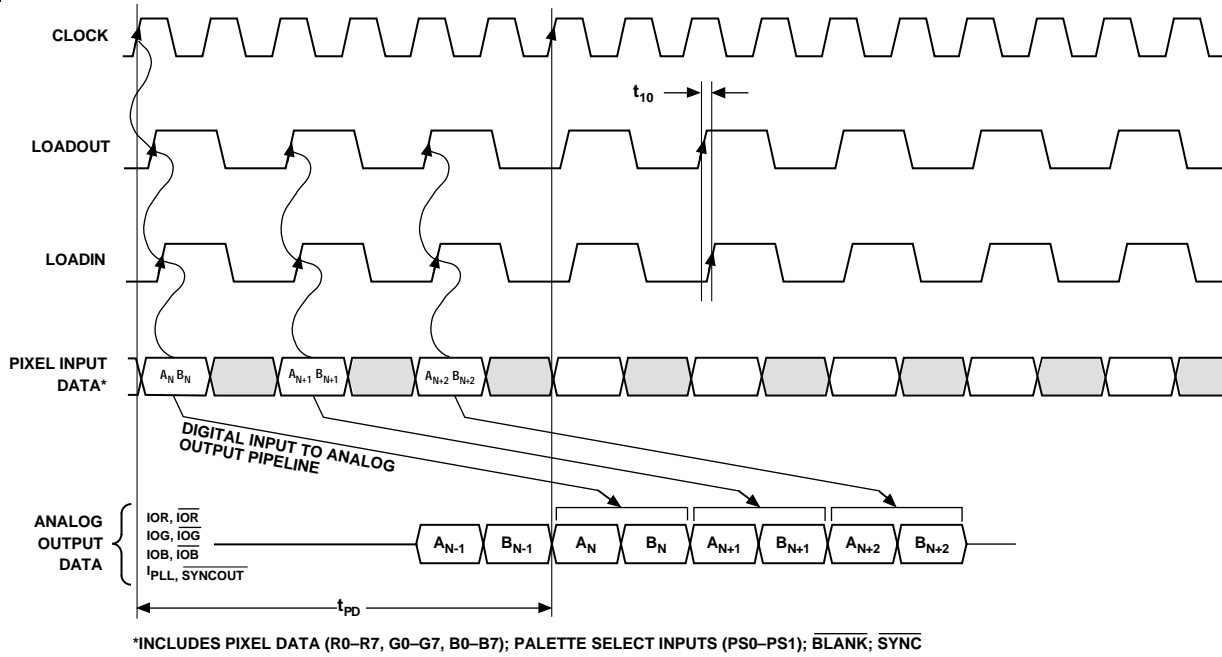

Figure 6. Pixel Input to Analog Output Pipeline with Minimum LOADOUT to LOADIN Delay (2:1 Multiplex Mode)

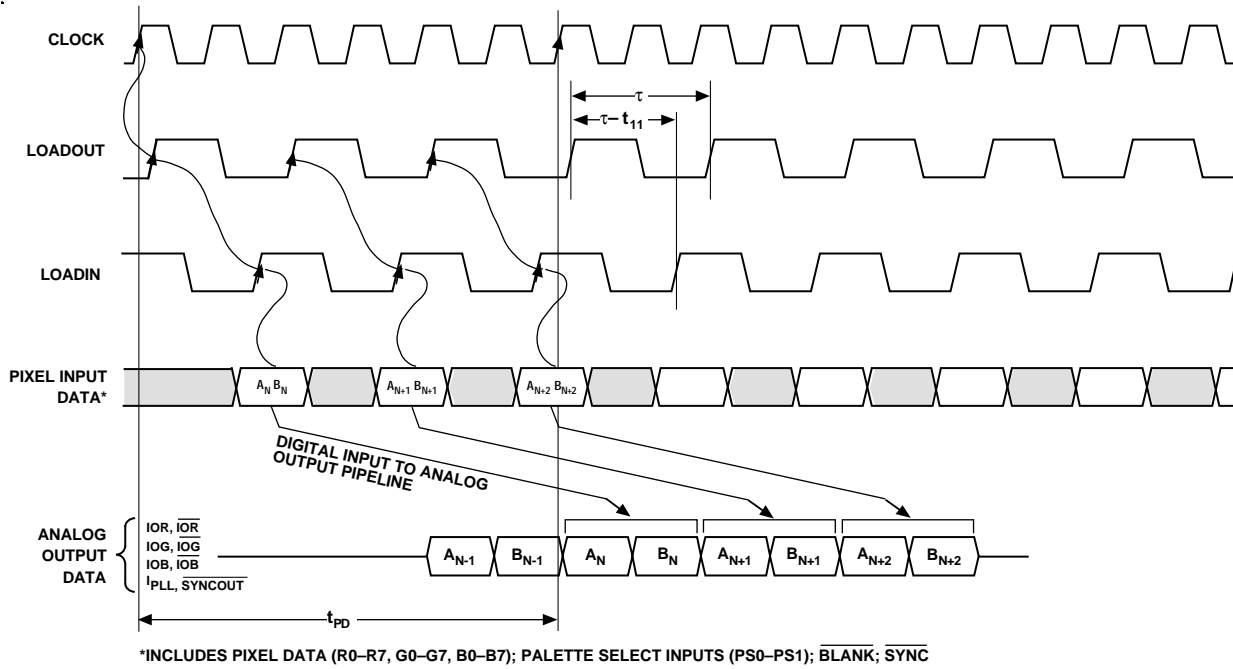

Figure 7. Pixel Input to Analog Output Pipeline with Maximum LOADOUT to LOADIN Delay (2:1 Multiplex Mode)

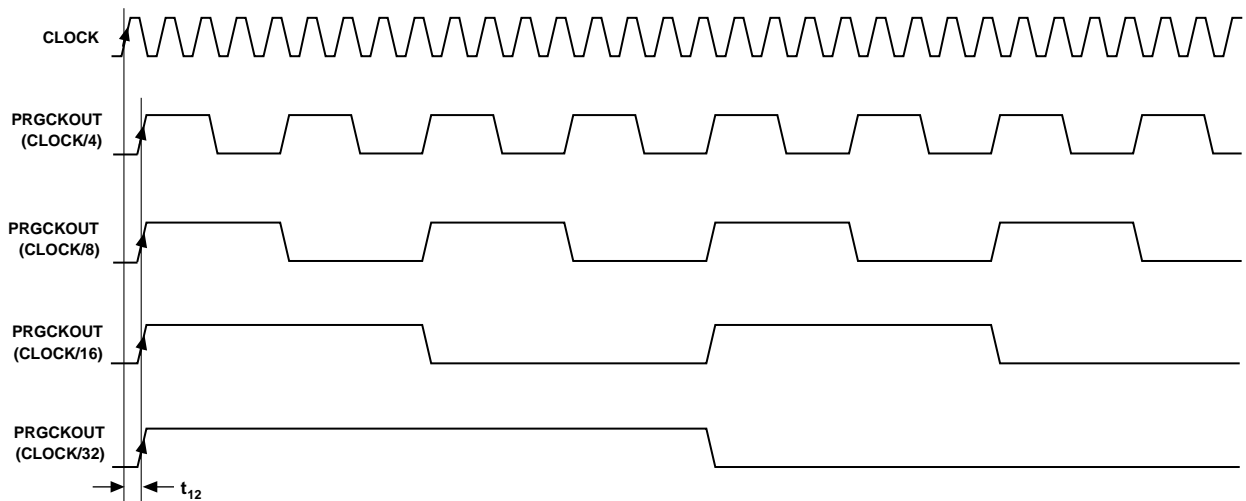

Figure 8. Pixel Clock Input vs. Programmable Clock Output (PRGCKOUT)

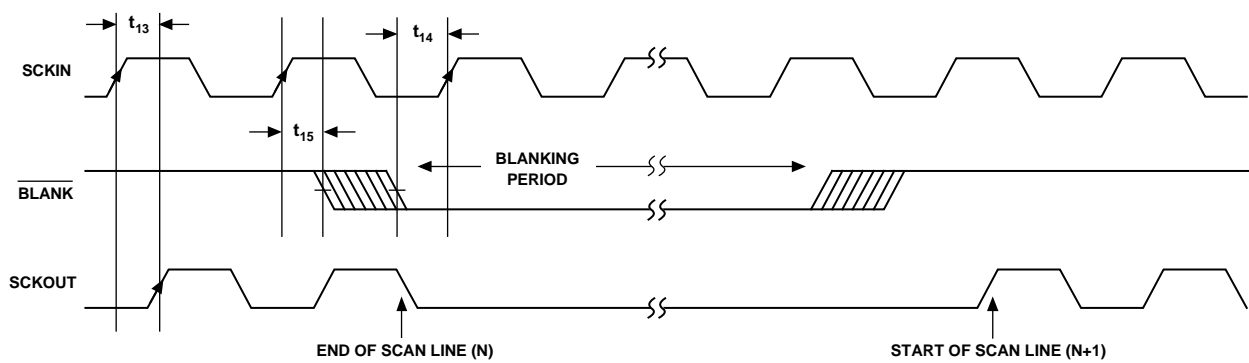
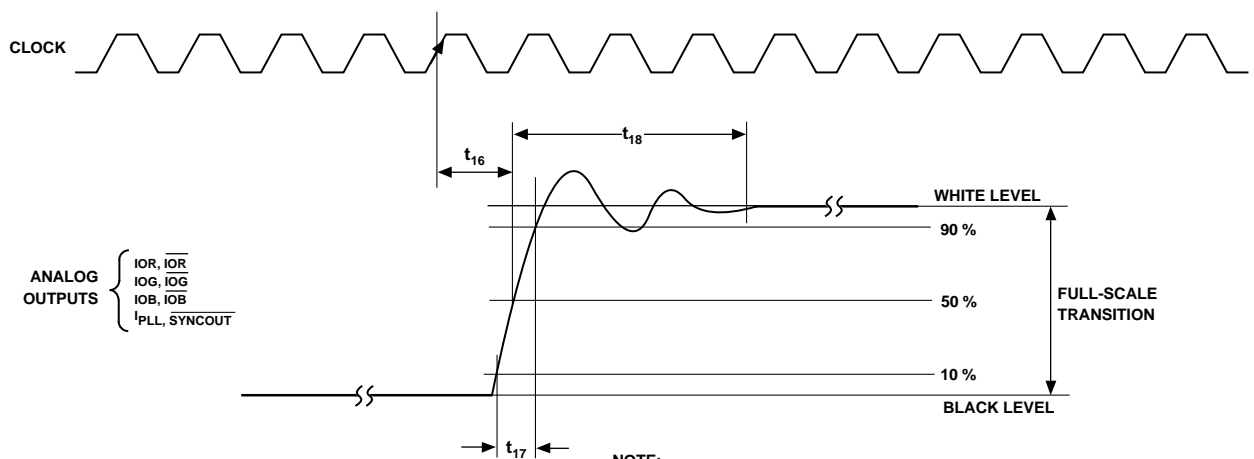

Figure 9. Video Data Shift Clock Input (SCKIN) & BLANK vs. Video Data Shift Clock Output (SCKOUT)



NOTE:
 THIS DIAGRAM IS NOT TO SCALE. FOR THE PURPOSES OF CLARITY, THE ANALOG OUTPUT WAVEFORM IS MAGNIFIED IN TIME AND AMPLITUDE W.R.T THE CLOCK WAVEFORM. I_{PLL} AND SYNCOUT ARE DIGITAL VIDEO OUTPUT SIGNALS. t_{16} IS THE ONLY RELEVANT OUTPUT TIMING SPECIFICATION FOR I_{PLL} AND SYNCOUT.

Figure 10. Analog Output Response vs. CLOCK

ADV7150

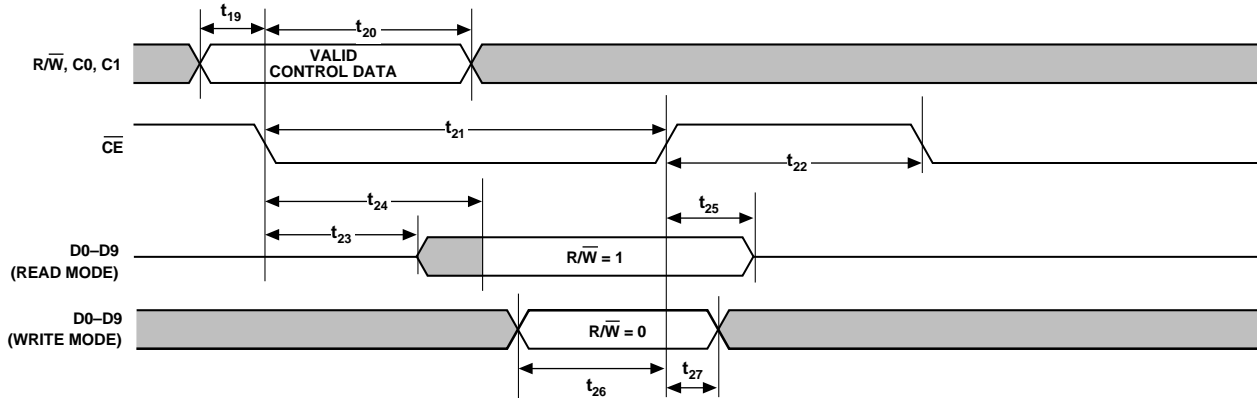

Figure 11. Microprocessor Port (MPU) Interface Timing

RECOMMENDED OPERATING CONDITION

Parameter	Symbol	Min	Typ	Max	Units
Power Supply	V_{AA}	4.75	5.00	5.25	Volts
Ambient Operating Temperature	T_A	0		+70	°C
Reference Voltage	V_{REF}	1.14	1.235	1.26	Volts
Output Load	R_L		37.5		Ω

CAUTION

ESD (electrostatic discharge) sensitive device. Electrostatic charges as high as 4000 V readily accumulate on the human body and test equipment and can discharge without detection. Although the ADV7150 features proprietary ESD protection circuitry, permanent damage may occur on devices subjected to high energy electrostatic discharges. Therefore, proper ESD precautions are recommended to avoid performance degradation or loss of functionality.



ABSOLUTE MAXIMUM RATINGS¹

V_{AA} to GND 7 V
 Voltage on Any Digital Pin GND - 0.5 V to V_{AA} + 0.5 V
 Ambient Operating Temperature (T_A) -55°C to +125°C
 Storage Temperature (T_S) -65°C to +150°C
 Junction Temperature (T_J) +150°C
 Lead Temperature (Soldering, 10 secs) +260°C
 Vapor Phase Soldering (1 minute) +220°C
 Analog Outputs to GND² GND - 0.5 to V_{AA}

NOTES

¹Stresses above those listed under “Absolute Maximum Ratings” may cause permanent damage to the device. This is a stress rating only and functional operation of the device at these or any other conditions above those listed in the operational sections of this specification is not implied. Exposure to absolute maximum rating conditions for extended periods may affect device reliability.

²Analog Output Short Circuit to any Power Supply or Common can be of an indefinite duration.

ORDERING GUIDE^{1, 2, 3}

Speed			
220 MHz	ADV7150LS220	110 MHz	ADV7150LS110
170 MHz	ADV7150LS170	85 MHz	ADV7150LS85
135 MHz	ADV7150LS135		

NOTES

¹ADV7150 is packaged in a 160-pin plastic quad flatpack, QFP.

²All devices are specified for 0°C to +70°C operation.

³Contact sales office for latest information on package design.

16-Lead QFP Configuration

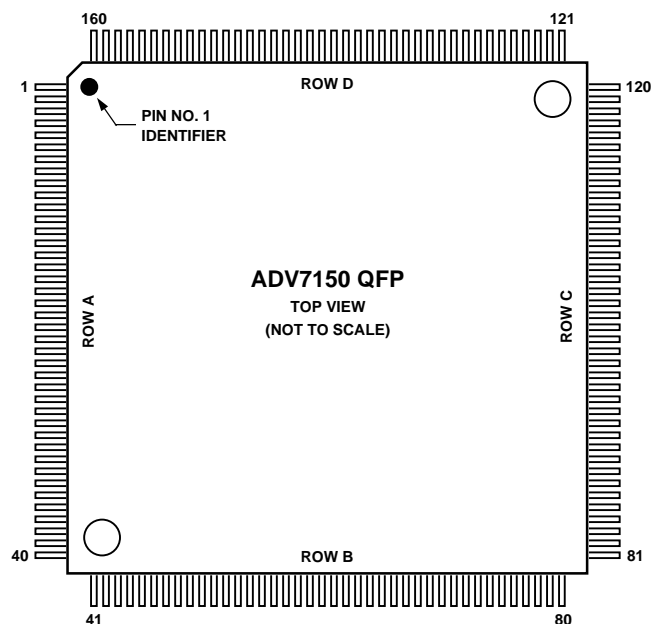

ADV7150 PIN ASSIGNMENTS

Pin Number	Mnemonic	Pin Number	Mnemonic	Pin Number	Mnemonic	Pin Number	Mnemonic
1	G3 _A	41	PS1 _D	81	NC	121	R1 _A
2	G3 _B	42	B0 _A	82	D2	122	R1 _B
3	G3 _C	43	B0 _B	83	NC	123	R1 _C
4	G3 _D	44	B0 _C	84	GND	124	R1 _D
5	G4 _A	45	B0 _D	85	GND	125	R2 _A
6	G4 _B	46	B1 _A	86	GND	126	R2 _B
7	G4 _C	47	B1 _B	87	D3	127	R2 _C
8	G4 _D	48	B1 _C	88	D4	128	R2 _D
9	G5 _A	49	B1 _D	89	D5	129	R3 _A
10	G5 _B	50	B2 _A	90	V _{AA}	130	R3 _B
11	G5 _C	51	B2 _B	91	D6	131	R3 _C
12	G5 _D	52	B2 _C	92	D7	132	R3 _D
13	CLOCK	53	B2 _D	93	D8	133	R4 _A
14	CLOCK	54	B3 _A	94	D9	134	R4 _B
15	LOADIN	55	B3 _B	95	GND	135	R4 _C
16	LOADOUT	56	B3 _C	96	GND	136	R4 _D
17	V _{AA}	57	B3 _D	97	GND	137	R5 _A
18	V _{AA}	58	B4 _A	98	$\overline{\text{IOB}}$	138	R5 _B
19	PRGCKOUT	59	B4 _B	99	$\overline{\text{IOR}}$	139	R5 _C
20	SCKIN	60	B4 _C	100	$\overline{\text{IOG}}$	140	R5 _D
21	SCKOUT	61	B4 _D	101	IOB	141	R6 _A
22	$\overline{\text{SYNCOUT}}$	62	B5 _A	102	IOG	142	R6 _B
23	GND	63	B5 _B	103	V _{AA}	143	R6 _C
24	GND	64	B5 _C	104	V _{AA}	144	R6 _D
25	GND	65	B5 _D	105	V _{AA}	145	R7 _A
26	G6 _A	66	B6 _A	106	IOR	146	R7 _B
27	G6 _B	67	B6 _B	107	COMP	147	R7 _C
28	G6 _C	68	B6 _C	108	V _{REF}	148	R7 _D
29	G6 _D	69	B6 _D	109	R _{SET}	149	G0 _A
30	G7 _A	70	B7 _A	110	I _{PLL}	150	G0 _B
31	G7 _B	71	B7 _B	111	GND	151	G0 _C
32	G7 _C	72	B7 _C	112	V _{AA}	152	G0 _D
33	G7 _D	73	$\overline{\text{B7D}}$	113	V _{AA}	153	G1 _A
34	PS0 _A	74	$\overline{\text{CE}}$	114	V _{AA}	154	G1 _B
35	PS0 _B	75	R/ $\overline{\text{W}}$	115	$\overline{\text{SYNC}}$	155	G1 _C
36	PS0 _C	76	C0	116	$\overline{\text{BLANK}}$	156	G1 _D
37	PS0 _D	77	C1	117	R0 _A	157	G2 _A
38	PS1 _A	78	D0	118	R0 _B	158	G2 _B
39	PS1 _B	79	D1	119	R0 _C	159	G2 _C
40	PS1 _C	80	GND	120	R0 _D	160	G2 _D

NC = No Connect.

PIN FUNCTION DESCRIPTION

Mnemonic	Function
RED (R0 _A . . . R0 _D -R7 _A . . . R7 _D), GREEN (G0 _A . . . G0 _D -G7 _A . . . G7 _D), BLUE (B0 _A . . . B0 _D -B7 _A . . . B7 _D)	Pixel Port (TTL Compatible Inputs): 96 pixel select inputs, with 8 bits each for Red, 8 bits for Green and 8 bits for Blue. Each bit is multiplexed [A-D] 4:1, 2:1 or 1:1. It can be configured for 24-Bit True-Color Data, 8-Bit Pseudo-Color Data and 15-Bit True-Color Data formats. Pixel Data is latched into the device on the rising edge of LOADIN.
PS0 _A . . . PS0 _D , PS1 _A . . . PS1 _D	Palette Priority Selects (TTL Compatible Inputs): These pixel port select inputs determine whether or not the device's pixel data port is selected on a pixel by pixel basis. The palette selects allow switching between multiple palette devices. The device can be preprogrammed to completely shut off the DAC analog outputs. If the values of PS0 and PS1 match the values programmed into bits MR16 and MR17 of the Mode Register, then the device is selected. Each bit is multiplexed [A-D] 4:1, 2:1 or 1:1. PS0 and PS1 are latched into the device on the rising edge of LOADIN.
LOADIN	Pixel Data Load Input (TTL Compatible Input). This input latches the multiplexed pixel data, including PS0-PS1, $\overline{\text{BLANK}}$ and $\overline{\text{SYNC}}$ into the device.
LOADOUT	Pixel Data Load Output (TTL Compatible Output). This output control signal runs at a divided down frequency of the pixel CLOCK input. Its frequency is a function of the multiplex rate. It can be used to directly or indirectly drive LOADIN $f_{\text{LOADOUT}} = f_{\text{CLOCK}}/M$ where $M = 1$ for 1:1 Multiplex Mode $M = 2$ for 2:1 Multiplex Mode $M = 4$ for 4:1 Multiplex Mode.
PRGCKOUT	Programmable Clock Output (TTL Compatible Output). This output control signal runs at a divided down frequency of the pixel CLOCK input. Its frequency is user programmable and is determined by bits CR30 and CR31 of Command Register 3 $f_{\text{PRGCKOUT}} = f_{\text{CLOCK}}/N$ where $N = 4, 8, 16$ and 32 .
SCKIN	Video Shift Clock Input (TTL Compatible Input). The signal on this input is internally gated synchronously with the $\overline{\text{BLANK}}$ signal. The resultant output, SCKOUT, is a video clocking signal that is stopped during video blanking periods.
SCKOUT	Video Shift Clock Output (TTL Compatible Output). This output is a synchronously gated version of SCKIN and $\overline{\text{BLANK}}$. SCKOUT, is a video clocking signal that is stopped during video blanking periods.
CLOCK, $\overline{\text{CLOCK}}$	Clock Inputs (ECL Compatible Inputs). These differential clock inputs are designed to be driven by ECL logic levels configured for single supply (+5 V) operation. The clock rate is normally the pixel clock rate of the system.
$\overline{\text{BLANK}}$	Composite Blank (TTL Compatible Input). This video control signal drives the analog outputs to the blanking level.
$\overline{\text{SYNC}}$	Composite-Sync Input (TTL Compatible Input). This video control signal drives the IOG analog output to the $\overline{\text{SYNC}}$ level. It is only asserted during the blanking period. CR22 in Command Register 2 must be set if $\overline{\text{SYNC}}$ is to be decoded onto the analog output, otherwise the $\overline{\text{SYNC}}$ input is ignored.
$\overline{\text{SYNCOUT}}$	Composite-Sync Output (TTL Compatible Output). This video output is a delayed version of $\overline{\text{SYNC}}$. The delay corresponds to the number of pipeline stages of the device.
D0-D9	Databus (TTL Compatible Input/Output Bus). Data, including color palette values and device control information is written to and read from the device over this 10-bit, bidirectional databus. 10-bit data or 8-bit data can be used. The databus can be configured for either 10-bit parallel data or byte data (8+2) as well as standard 8-bit data. Any unused bits of the databus should be terminated through a resistor to either the digital power plane (V_{CC}) or GND.
$\overline{\text{CE}}$	Chip Enable (TTL Compatible Input). This input must be at Logic "0," when writing to or reading from the device over the databus (D0-D9). Internally, data is latched on the rising edge of $\overline{\text{CE}}$.

Mnemonic	Function
R/\overline{W}	Read/Write Control (TTL Compatible Input). This input determines whether data is written to or read from the device's registers and color palette RAM. R/\overline{W} and \overline{CE} must be at Logic "0" to write data to the part. R/\overline{W} must be at Logic "1" and \overline{CE} at Logic "0" to read from the device.
C0, C1	Command Controls (TTL Compatible Inputs). These inputs determine the type of read or write operation being performed on the device over the databus (see Interface Truth Table). Data on these inputs is latched on the falling edge of \overline{CE} .
\overline{IOR} ; \overline{IOG} ; \overline{IOB}	Red, Green and Blue Current Outputs (High Impedance Current Sources). These RGB video outputs are specified to directly drive RS-343A and RS-170 video levels into doubly terminated 75 Ω loads. \overline{IOR} , \overline{IOG} and \overline{IOB} are the complementary outputs of IOR, IOG and IOB. These outputs can be tied to GND if it is not required to use differential outputs.
V_{REF}	Voltage Reference Input (Analog Input). An external 1.235 V voltage reference is required to drive this input. An AD589 (2-terminal voltage reference) or equivalent is recommended. (Note: It is not recommended to use a resistor network to generate the voltage reference.)
R_{SET}	Output Full-Scale Adjust Control (Analog Input). A resistor connected between this pin and analog ground controls the absolute amplitude of the output video signal. The value of R_{SET} is derived from the full-scale output current on IOG according to the following equations: $R_{SET} (\Omega) = C1 \times V_{REF}/IOG (mA); \overline{SYNC} \text{ on GREEN}$ $R_{SET} (\Omega) = C2 \times V_{REF}/IOG (mA); \text{NO SYNC on GREEN.}$ Full-Scale output currents on IOR and IOB for a particular value of R_{SET} are given by: $IOR (mA) = C2 \times V_{REF}(V)/R_{SET} (\Omega)$ and $IOB (mA) = C2 \times V_{REF} (V)/R_{SET} (\Omega)$ where $C1 = 6,050$; PEDESTAL = 7.5 IRE = 5,723; PEDESTAL = 0 IRE and $C2 = 4,323$; PEDESTAL = 7.5 IRE = 3,996; PEDESTAL = 0 IRE.
COMP	Compensation Pin. A 0.1 μ F capacitor should be connected between this pin and V_{AA} .
I_{PLL}	Phase Lock Loop Output Current (High Impedance Current Source). This output is used to enable multiple ADV7150s along with ADV7151s to be synchronized together with pixel resolution when using an external PLL. This output is triggered either from the falling edge of SYNC or BLANK as determined by bit CR21 of Command Register 2. When activated, it supplies a current corresponding to: $I_{PLL} (mA) = 1,728 \times V_{REF}(V)/R_{SET} (\Omega)$ When not using the I_{PLL} function, this output pin should be tied to GND.
V_{AA}	Power Supply (+5 V \pm 5%). The part contains multiple power supply pins, all should be connected together to one common +5 V filtered analog power supply.
GND	Analog Ground. The part contains multiple ground pins, all should be connected together to the system's ground plane.

ADV7150

(Continued from page 1)

The device consists of three, high speed, 10-bit, video D/A converters (RGB), three 256×10 (one 256×30) color look-up tables, palette priority selects, a pixel input data multiplexer/serializer and a clock generator/divider circuit. The ADV7150 is capable of 1:1, 2:1 and 4:1 multiplexing. The onboard palette priority select inputs enable multiple palette devices to be connected together for use in multipalette and window applications. The part is controlled and programmed through the microprocessor (MPU) port. The part also contains a number of onboard test registers, associated with self diagnostic testing of the device. The individual Red, Green and Blue pixel input ports allow True-Color, image rendition. True-Color image rendition, at speeds of up to 220 MHz, is achieved through the use of the onboard data multiplexer/serializer. The pixel input port's flexibility allows for direct interface to most standard frame buffer memory configurations.

The 30 bits of resolution, associated with the color look-up table and triple 10-bit DAC, realizes 24-bit True-Color resolution, while also allowing for the onboard implementation of linearization algorithms, such as Gamma-Correction. This allows effective 30-Bit True-Color operation.

The on-chip video clock controller circuit generates all the internal clocking and some additional external clocking signals. An external ECL oscillator source with differential outputs is all that is required to drive the **CLOCK** and **CLOCK** inputs of the ADV7150. The part can also be driven by an external clock generator chip circuit, such as the AD730.

The ADV7150 is capable of generating RGB video output signals which are compatible with RS-343A and RS-170 video standards, without requiring external buffering.

Test diagnostic circuitry has been included to complement the users system level debugging.

The ADV7150 is fabricated in a +5 V CMOS process. Its monolithic CMOS construction ensures greater functionality with low power dissipation.

The ADV7150 is packaged in a plastic 160-pin power quad flat-pack (QFP). Superior thermal dissipation is achieved by inclusion of a copper heatslug, within the standard package outline to which the die is attached.

CIRCUIT DETAILS AND OPERATION

OVERVIEW

Digital video or pixel data is latched into the ADV7150 over the devices Pixel Port. This data acts as a pointer to the onboard Color Palette RAM. The data at the RAM address pointed to is latched into the digital-to-analog converters (DACs) and output as an RGB analog video signal.

For the purposes of clarity of description, the ADV7150 is broken down into three separate functional blocks. These are:

1. Pixel port and clock control circuit
2. MPU port, registers and color palette
3. Digital-to-analog converters and video outputs

Table I shows the architectural and packaging differences between other devices in the ADV715x series of workstation parts. (For more details consult the relevant data sheets.)

Table I. Architectural and Packaging Differences of the ADV715x Series

Description	ADV7150	ADV7152*	ADV7151*
24-Bit "Gamma" True Color	•	•	
24-Bit "Standard" True Color	•	•	
8-Bit "Gamma" Pseudo Color	•	•	•
8-Bit "Standard" Pseudo Color	•	•	•
15-Bit True Color	•	•	
220 MHz – True Color	•	•	
220 MHz – Pseudo Color	•	•	•
Triple 10-Bit DACs	•	•	•
4:1 Multiplexing	•	•	•
2:1 Multiplexing	•	•	•
1:1 Multiplexing	•	•	•
160-Lead QFP	•		
100-Lead QFP		•	•

*See ADV7151 and ADV7150 data sheets for more information on these parts.

Pixel Port and Clock Control Circuit

The Pixel Port of the ADV7150 is directly interfaced to the video/graphics pipeline of a computer graphics subsystem. It is connected directly or through a gate array to the video RAM of the systems Frame-Buffer (video memory). The pixel port on the device consists of:

Color Data RED, GREEN, BLUE
 Pixel Controls SYNC, BLANK
 Palette Selects PS0-PS1

The associated clocking signals for the pixel port include:

Clock Inputs CLOCK, CLOCK,
 LOADIN, SCKIN
 Clock Outputs LOADOUT, PRGCKOUT,
 SCKOUT

These onboard clock control signals are included to simplify interfacing between the part and the frame buffer. Only two control input signals are necessary to get the part operational, **CLOCK** and **CLOCK** (ECL Levels). No additional signals or external glue logic are required to get the *Pixel Port & Clock Control Circuit* of the part operational.

Pixel Port (Color Data)

The ADV7150 has 96 color data inputs. The part has four (for 4:1 multiplexing) 24-bit wide direct color data inputs. These are user programmed to support a number of color data formats including 24-Bit True Color, 15-Bit True Color and 8-Bit Pseudo Color (see "Color Data Formats" section) in 4:1, 2:1 and 1:1 multiplex modes.

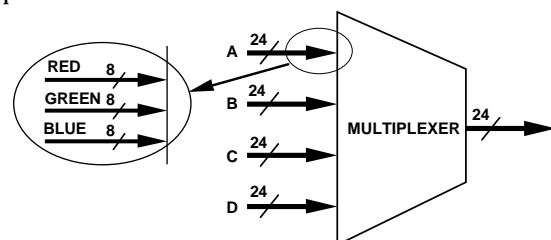

Figure 12. Multiplexed Color Inputs for the ADV7150

Color data is latched into the parts pixel port on every rising edge of LOADIN (see Timing Waveform, Figure 3). The required frequency of LOADIN is determined by the multiplex rate, where:

$$f_{LOADIN} = f_{CLOCK}/4 \quad 4:1 \text{ Multiplex Mode}$$

$$f_{LOADIN} = f_{CLOCK}/2 \quad 2:1 \text{ Multiplex Mode}$$

$$f_{LOADIN} = f_{CLOCK} \quad 1:1 \text{ Multiplex Mode}$$

Other pixel data signals latched into the device by LOADIN include SYNC, BLANK and PS0-PS1.

Internally, data is pipelined through the part by the differential pixel clock inputs, CLOCK and C \overline{LOCK} . The LOADIN control signal needs only have a frequency synchronous relationship to the pixel CLOCK (see "Pipeline Delay & Onboard Calibration" section). A completely phase independent LOADIN signal can be used with the ADV7150, allowing the CLOCK to occur anywhere during the LOADIN cycle.

Alternatively, the LOADOUT signal of the ADV7150 can be used. LOADOUT can be connected either directly or indirectly to LOADIN. Its frequency is automatically set to the correct LOADIN requirement.

SYNC, BLANK

The BLANK and SYNC video control signals drive the analog outputs to the blanking and SYNC levels respectively. These signals are latched into the part on the rising edge of LOADIN. The SYNC information is encoded onto the IOG analog signal when Bit CR22 of Command Register 2 is set to a Logic "1." The SYNC input is ignored if CR22 is set to "0."

SYNCOUT

In some applications where it is not permissible to encode SYNC on green (IOG), SYNCOUT can be used as a separate TTL digital SYNC output. This has the advantage over an independent (of the ADV7150) SYNC in that it does not necessitate knowing the absolute pipeline delay of the part. This allows complete independence between LOADIN/Pixel Data and CLOCK. The SYNC input is connected to the device as normal with Bit CR22 of Command Register 2 set to "0" thereby preventing SYNC from being encoded onto IOG. Bit CR12 of Command Register 1 is set to "1," enabling SYNCOUT. The output signal generates a TTL SYNCOUT with correct pipeline delay that is capable of directly driving the composite SYNC signal of a computer monitor.

PS0-PS1 (Palette Priority Select Inputs)

These pixel port select inputs determine whether or not the device is selected. These controls effectively determine whether the devices RGB analog outputs are turned-on or shut down. When the analog outputs are shut down, IOR, IOG and IOB are forced to 0 mA regardless of the state of the pixel and control data inputs. This state is determined on a pixel by pixel basis as the PS0-PS1 inputs are multiplexed in exactly the same format as the pixel port color data. These controls allow for switching between multiple palette devices (see Appendix 4). If the values of PS0 and PS1 match the values programmed into bits MR16 and MR17 of the Mode Register, then the device is selected, if there is no match the device is effectively shut down.

Multiplexing

The onboard multiplexers of the ADV7150 eliminate the need for external data serializer circuits. Multiple video memory devices can be connected, in parallel, directly to the device.

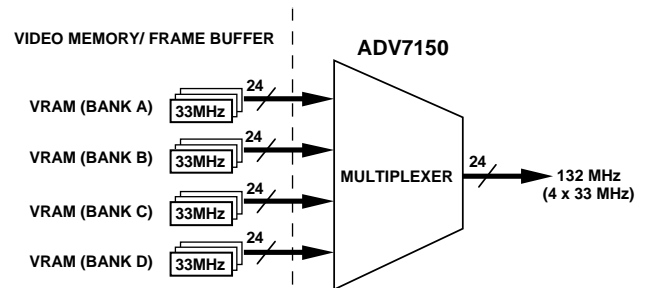

Figure 13. Direct Interfacing of Video Memory to ADV7150

Figure 13 shows four memory banks of 33 MHz memory connected to the ADV7150, running in 4:1 multiplex mode, giving a resultant pixel or dot clock rate of 132 MHz. As mentioned in the previous section, the ADV7150 supports a number of color data formats in 4:1, 2:1 and 1:1 multiplex modes.

In 1:1 multiplex mode, the ADV7150 is clocked using the LOADIN signal. This means that there is no requirement for differential ECL inputs on CLOCK and C \overline{LOCK} . The pixel clock is connected directly to LOADIN. (Note: The ECL CLOCK can still be used to generate LOADOUT PRGCKOUT, etc.)

CLOCK CONTROL CIRCUIT

The ADV7150 has an integrated Clock Control Circuit (Figure 14). This circuit is capable of both generating the ADV7150's internal clocking signals as well as external graphics subsystem clocking signals. Total system synchronization can be attained by using the parts output clocking signals to drive the controlling graphics processor's master clock as well as the video frame buffers shift clock signals.

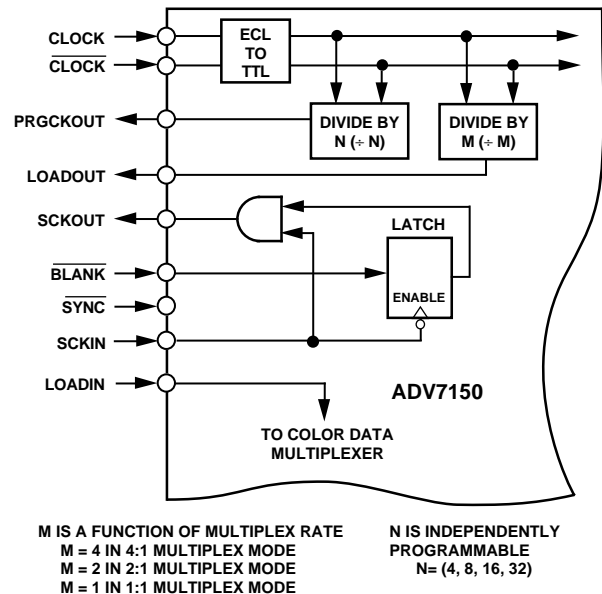

Figure 14. Clock Control Circuit of the ADV7150

ADV7150

CLOCK, $\overline{\text{CLOCK}}$ Inputs

The Clock Control Circuit is driven by the pixel clock inputs, CLOCK and $\overline{\text{CLOCK}}$. These inputs can be driven by a differential ECL oscillator running from a +5 V supply.

Alternatively, the ADV7150 CLOCK inputs can be driven by a Programmable Clock Generator (Figure 15), such as the ICS1562. The ICS1562 is a monolithic, phase-locked-loop, clock generator chip. It is capable of synthesizing differential ECL output frequencies in a range up to 220 MHz from a single low frequency reference crystal.

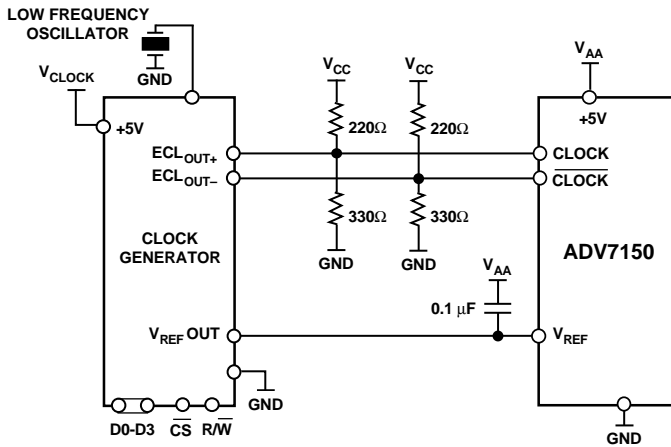

Figure 15. PLL Generator Driving CLOCK , $\overline{\text{CLOCK}}$ of the ADV7150

CLOCK CONTROL SIGNALS

LOADOUT

The ADV7150 generates a LOADOUT control signal which runs at a divided down frequency of the pixel CLOCK . The frequency is automatically set to the programmed multiplex rate, controlled by CR37 and CR36 of Command Register 3.

$$\begin{aligned} f_{\text{LOADOUT}} &= f_{\text{CLOCK}}/4 && 4:1 \text{ Multiplex Mode} \\ f_{\text{LOADOUT}} &= f_{\text{CLOCK}}/2 && 2:1 \text{ Multiplex Mode} \\ f_{\text{LOADOUT}} &= f_{\text{CLOCK}} && 1:1 \text{ Multiplex Mode} \end{aligned}$$

The LOADOUT signal is used to directly drive the LOADIN pixel latch signal of the ADV7150. This is most simply achieved by tying the LOADOUT and LOADIN pins together. Alternatively, the LOADOUT signal can be used to drive the frame buffer's shift clock signals, returning to the LOADIN input delayed with respect to LOADOUT .

If it is not necessary to have a known fixed number of pipeline delays, then there is no limitation on the delay between LOADOUT and LOADIN ($\text{LOADOUT}(1)$ and $\text{LOADOUT}(2)$).

LOADIN and Pixel Data must conform to the setup and hold times (t_8 and t_9).

If, however, it is required that the ADV7150 has a fixed number of pipeline delays (t_{PD}), LOADOUT and LOADIN must conform to timing specifications t_{10} and τ_{t11} as illustrated in Figures 4 to 7.

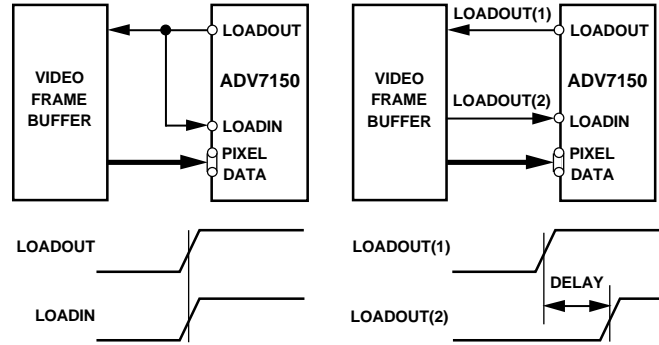

Figure 16. LOADOUT vs. Pixel Clock Input (CLOCK , $\overline{\text{CLOCK}}$)

PRGCKOUT

The PRGCKOUT control signal outputs a user programmable clock frequency. It is a divided down frequency of the pixel CLOCK (see Figure 8). The rising edge of PRGCKOUT is synchronous to the rising edge of LOADOUT

$$f_{\text{PRGCKOUT}} = f_{\text{CLOCK}}/N$$

where $N = 4, 8, 16$ or 32 .

One application of the PRGCKOUT is to use it as the master clock frequency of the graphics subsystems processor or controller.

SCKIN, SCKOUT

These video memory signals are used to minimize external support chips. Figure 17 illustrates the function that is provided. An input signal applied to SCKIN is synchronously AND-ed with the video blanking signal ($\overline{\text{BLANK}}$). The resulting signal is output on SCKOUT . Figure 9 of the Timing Waveform section shows the relationship between SCKOUT , SCKIN and $\overline{\text{BLANK}}$.

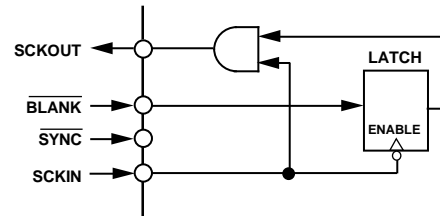

Figure 17. SCKOUT Generation Circuit

The SCKOUT signal is essentially the video memory shift control signal. It is stopped during the screen retrace. Figure 18 shows a suggested frame buffer to ADV7150 interface. This is a minimum chip solution and allows the ADV7150 control the overall graphics system clocking and synchronization.

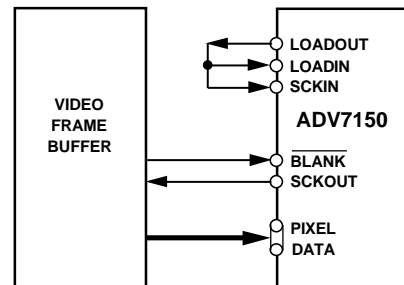

Figure 18. ADV7150 Interface Using SCKIN and SCKOUT

Pipeline Delay and Onboard Calibration

The ADV7150 has a fixed number of pipeline delays (t_{PD}), so long as timings t_{10} and $\tau-t_{11}$ are met. However, if a fixed pipeline delay is not a requirement, timings t_{10} and $\tau-t_{11}$ can be ignored, a calibration cycle must be run and there is no restriction on LOADIN to LOADOUT timing. If timings t_{10} and $\tau-t_{11}$ are not met, the part will function correctly though with an increased number of pipeline delays, $t_{PD} + N$ CLOCKS (for 4:1 mode $N = 4$, for 2:1 mode $N = 2$, for 1:1 mode $N = 0$). The ADV7150 has onboard calibration circuitry which synchronizes pixel data and LOADIN with the internal ADV7150 clocking signals. Calibration can be performed in two ways: during the devices initialization sequence by toggling two bits of the Mode Register, MR10 followed by MR15, or by writing a “1” to Bit CR10 of Command Register 1 which executes a calibration on every Vertical Sync.

COLOR VIDEO MODES

The ADV7150 supports a number of color video modes all at the maximum video rate.

Command bits CR24–CR27 of Command Register 2 along with Bit MR11 of Mode Register 1 determine the color mode.

24-Bit “Gamma” True Color (CR25, CR26, CR27 = 1, 1, 1 and MR11 = 1)

The part is set to 24-bit/30-bit True-Color operation. The pixel port accepts 24 bits of color data which is directly mapped to the Look-Up Table RAM. The Look-Up Table is configured as a 256 location by 30 bits deep RAM (10 bits each for Red, Green and Blue). The output of the RAM drives the DACs with 30-bit data (10 bits each for Red, Green and Blue). The RAM is preloaded with a user determined, nonlinear function, such as a gamma correction curve.

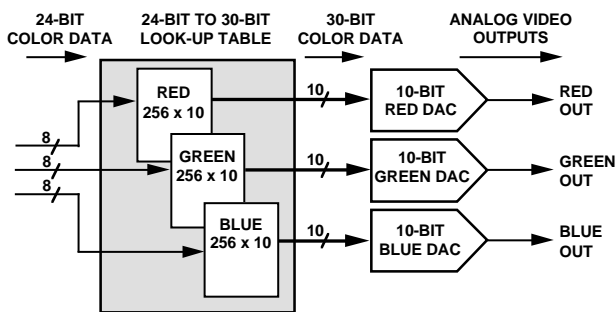

Figure 19. 24-Bit to 30-Bit True-Color Configuration

This mode allows for the display of full 24-bit, Gamma-Corrected True-Color Images.

24-Bit “Standard” True Color (CR25, CR26, CR27 = 1, 1, 1 and MR11 = 0)

This mode sets the part into direct 24-bit True-Color operation. The pixel port accepts 24 bits of color data which is directly mapped to Look-Up Table RAM. The Look-Up Table is configured as a 256 location by 24 bits deep RAM (8 bits each for Red, Green and Blue) and essentially acts as a bypass RAM. The output of the RAM drives the DACs with 24-bit data (8 bits each for Red, Green and Blue). The RAM is preloaded with a linear function.

This mode allows for the display of full 24-bit True-Color Images.

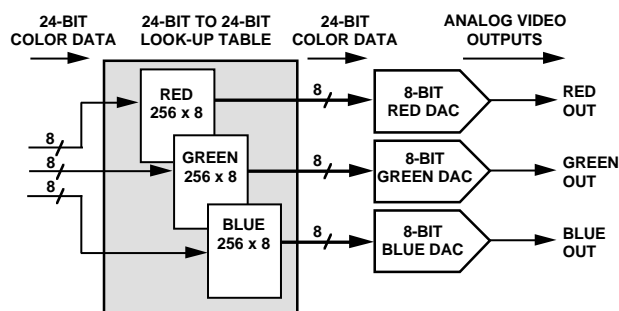

Figure 20. 24-Bit to 24-Bit Direct True-Color Configuration

8-Bit “Gamma” Pseudo Color (CR25, CR26, CR27 = X, 0, 0 or X, 1, 0 or X, 0, 1 and MR11 = 1)

This mode sets the part into 8-bit Pseudo-Color operation. The pixel port accepts 8 bits of pixel data which indexes a 30-bit word in the Look-Up Table RAM. The Look-Up Table is configured as a 256 location by 30 bits deep RAM (10 bits each for Red, Green and Blue). The output of the RAM drives the DACs with 30-bit data (10 bits each for Red, Green and Blue).

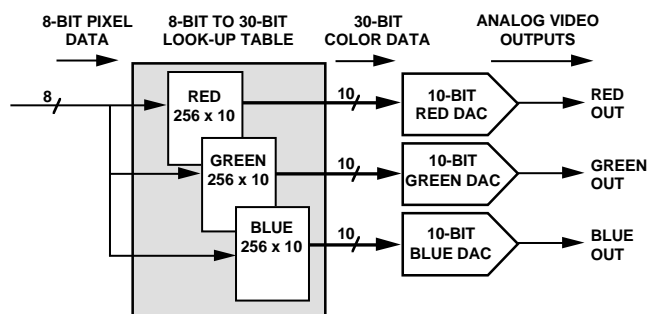

Figure 21. 8-Bit to 30-Bit Pseudo-Color Configuration

This mode allows for the display of 256 simultaneous colors out of a total palette of millions of addressable colors.

8-Bit “Standard” Pseudo Color (CR25, CR26, CR27 = X, 0, 0 or X, 1, 0 or X, 0, 1 and MR11 = 0)

This mode sets the part into 8-bit Pseudo-Color operation. The pixel port accepts 8 bits of pixel data which indexes a 24-bit word in the Look-Up Table RAM. The Look-Up Table is configured as a 256 location by 24 bits deep RAM (8 bits each for Red, Green and Blue). The output of the RAM drives the DACs with 24-bit data (8 bits each for Red, Green and Blue).

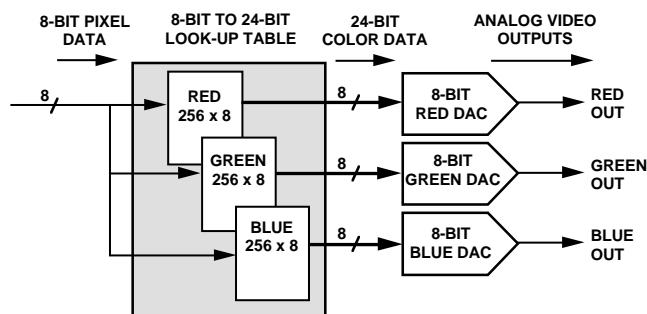

Figure 22. 8-Bit to 24-Bit Pseudo-Color Configuration

This mode allows for the display of 256 simultaneous colors out of a total palette of millions of addressable colors.

ADV7150

15-Bit "Gamma" True Color

(CR24, CR25, CR26, CR27 = 0, 0, 1, 1 or 1, 0, 1, 1 and MR11 = 1)

The part is set to 15-bit True-Color operation. The pixel port accepts 15-bits of color data which is mapped to the 5 LSBs of each of the red, green and blue palettes of the Look-Up Table RAM. The Look-Up Table is configured as a 32 location by 30 bits deep RAM (10 bits each for Red, Green and Blue). The output of the RAM drives the DACs with 30-bit data (10 bits each for Red, Green and Blue).

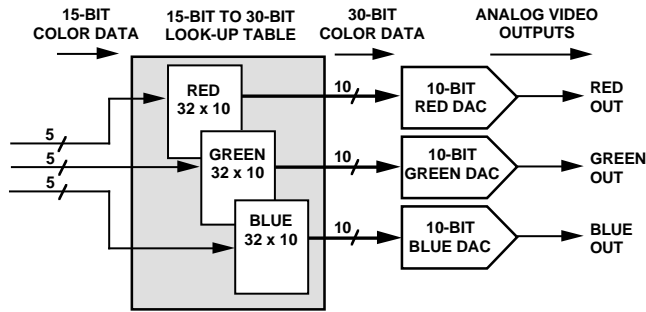

Figure 23. 15-Bit to 30-Bit True-Color Configuration

This mode allows for the display of 15-bit, Gamma-Corrected True-Color Images.

15-Bit "Standard" True Color

(CR24, CR25, CR26, CR27 = 0, 0, 1, 1 or 1, 0, 1, 1 and MR11 = 0)

The part is set to 15-bit True-Color operation. The pixel port accepts 15 bits of color data which is mapped to the 5 LSBs of each of the red, green and blue palettes of the Look-Up Table RAM. The Look-Up Table is configured as a 32 location by 24 bits deep RAM (8 bits each for Red, Green and Blue). The output of the RAM drives the DACs with 24-bit data (8 bits each for Red, Green and Blue).

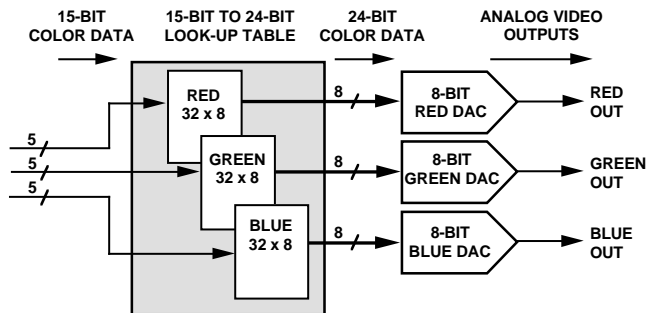

Figure 24. 15-Bit to 24-Bit True-Color Configuration

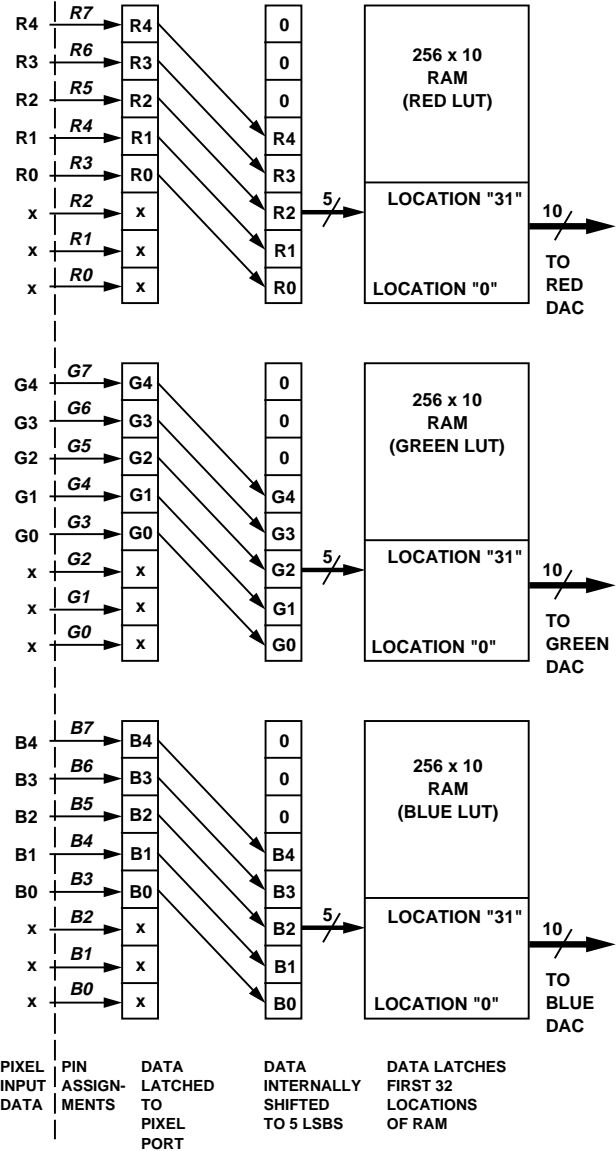

Figure 25. 15-Bit True-Color Mapping Using R3-R7, G3-G7 and B3-B7

This mode allows for the display of 15-bit True-Color Images.

PIXEL PORT MAPPING

The pixel data to the ADV7150 is automatically mapped in the parts pixel port as determined by the pixel data mode programmed (Bits CR24-CR27 of Command Register 2).

Pixel data in the 24-bit True-Color modes is directly mapped to the 24 color inputs R0-R7, G0-G7 and B0-B7.

There are three modes of operation for 8-bit Pseudo Color. Each mode maps the input pixel data differently. Data can be input one of the three color channels, R0-R7 or G0-G7 or B0-B7.

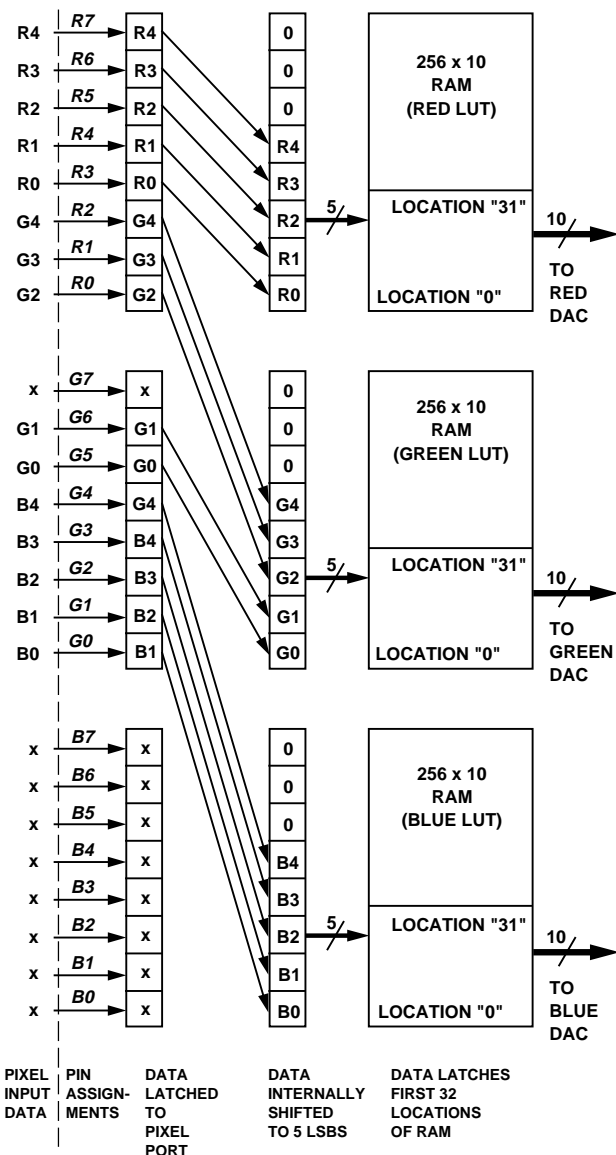

Figure 26. 15-Bit True-Color Mapping Using R0-R7 and G0-G6

The part has two modes of operation for 15-bit True Color. In the first mode, data is input to the device over the red, green and blue channel (R3-R7, G3-G7 and B3-B7) and is internally mapped to locations 0 to 31 of the Look-Up Table (LUT) according to Figure 25. In the second mode, data is input to the device over just two of the color ports, red and green (R0-R7 and G0-G6) and is internally mapped to LUT locations 0 to 31 according to Figure 26. (Note: Data on unused pixel inputs is ignored.)

MICROPROCESSOR (MPU) PORT

The ADV7150 supports a standard MPU Interface. All the functions of the part are controlled via this MPU port. Direct access is gained to the Address Register, Mode Register and all the Control Registers as well as the Color Palette. The following sections describe the setup for reading and writing to all of the devices registers.

MPU Interface

The MPU interface (Figure 27) consists of a bidirectional, 10-bit wide databus and interface control signals \overline{CE} , C0, C1 and R/W. The 10-bit wide databus is user configurable as illustrated.

Table II. Databus Width Table

Databus Width	RAM/DAC Resolution	Read/Write Mode
10-Bit	10-Bit	10-Bit Parallel
10-Bit	8-Bit	8-Bit Parallel
8-Bit	10-Bit	8+2 Byte
8-Bit	8-Bit	8-Bit Parallel

Register Mapping

The ADV7150 contains a number of onboard registers including the Mode Register (MR17-MR10), Address Register (A7-A0) and nine Control Registers as well as Red (R9-R0), Green (G9-G0) and Blue (B9-B0) Color Registers. These registers control the entire operation of the part. Figure 28 shows the internal register configuration.

Control lines C1 and C0 determine which register the MPU is accessing. C1 and C0 also determine whether the Address Register is pointing to the color registers and look-up table RAM or the control registers. If C1, C0 = 1, 0 the MPU has access to whatever control register is pointed to by the Address Register (A7-A0). If C1, C0 = 0, 1 the MPU has access to the Look-Up Table RAM (Color Palette) through the associated color registers. The \overline{CE} input latches data to or from the part.

The R/W control input determines between read or write accesses. The Truth Tables III and IV show all modes of access to the various registers and color palette for both the 8-bit wide databus configuration and 10-bit wide databus configuration. It should be noted that after power-up, the devices MPU port is automatically set to 10-bit wide operation (see Power-On Reset section).

Color Palette Accesses

Data is written to the color palette by first writing to the address register of the color palette location to be modified. The MPU performs three successive write cycles for each of the red, green and blue registers (10-bit or 8-bit). An internal pointer moves from red to green to blue after each write is completed. This pointer is reset to red after a blue write or whenever the address register is written. During the blue write cycle, the three bytes of red, green and blue are concatenated into a single 30-bit/24-bit word and written to the RAM location as specified in the address register (A7-A0). The address register then automatically increments to point to the next RAM location and a similar red, green and blue palette write sequence is performed. The address register resets to 00H following a blue write cycle to color palette RAM location FFH.

Table III. Interface Truth Table (10-Bit Databus Mode)

R/W	C1	C0	Databus (D9-D0)	Operation	Result
0	1	1	DB7-DB0	Write to Mode Register	DB7-DB0 → MR17-MR10
0	0	0	DB7-DB0	Write to Address Register	DB7-DB0 → A7-A0
0	1	0	DB7-DB0	Write to Control Registers (Particular Control Register Determined by Address Register)	DB7-DB0 → Control Register
0	0	1	DB9-DB0	Write to RED Register	DB9-DB0 → R9-R0
0	0	1	DB9-DB0	Write to GREEN Register	DB9-DB0 → G9-G0
0	0	1	DB9-DB0	Write to BLUE Register	DB9-DB0 → B9-B0
				Write RGB Data to RAM Location Pointed to by Address Register (A7-A0) Address Register = Address Register + 1	
1	1	1	DB7-DB0	Read Mode Register	MR17-MR10 → DB7-DB0
1	0	0	DB7-DB0	Read Address Register	A7-A0 → DB7-DB0
1	1	0	DB7-DB0	Read Control Registers (Particular Control Register Determined by Address Register)	Register Data → DB7-DB0
1	0	1	DB9-DB0	Read RED RAM Location	R9-R0 → DB9-DB0
1	0	1	DB9-DB0	Read GREEN RAM Location	G9-G0 → DB9-DB0
1	0	1	DB9-DB0	Read BLUE RAM Location (RAM Location Pointed to by Address Register (A7-A0)) Address Register = Address Register + 1	B9-B0 → DB9-DB0

DB = Data Bit.

Table IV. Interface Truth Table (8-Bit Databus Mode)*

R/W	C1	C0	Databus (D7-D0)	Operation	Result
0	1	1	DB7-DB0	Write to Mode Register	DB7-DB0 → MR17-MR10
0	0	0	DB7-DB0	Write to Address Register	DB7-DB0 → A7-A0
0	1	0	DB7-DB0	Write to Control Registers (Particular Control Register Determined by Address Register (A7-A0))	DB7-DB0 → Control Registers
0	0	1	DB9-DB2	Write to RED Register	DB9-DB2 → R9-R2
0	0	1	DB1-DB0	Write to RED Register	DB1-DB0 → R1-R0
0	0	1	DB9-DB2	Write to GREEN Register	DB9-DB2 → G9-G2
0	0	1	DB1-DB0	Write to GREEN Register	DB1-DB0 → G1-G0
0	0	1	DB9-DB2	Write to BLUE Register	DB9-DB2 → B9-B2
0	0	1	DB1-DB0	Write to BLUE Register	DB1-DB0 → B1-B0
				Write RGB Data to RAM Location Pointed to by Address Register (A7-A0) Address Register = Address Register + 1	
1	1	1	DB7-DB0	Read Mode Register	MR17-MR10 → DB7-DB0
1	0	0	DB7-DB0	Read Address Register	A7-A0 → DB7-DB0
1	1	0	DB7-DB0	Read Control Registers (Particular Control Register Determined by Address Register)	Register Data → DB7-DB0
1	0	1	DB9-DB2	Read RED RAM Location	R9-R2 → DB9-DB2
1	0	1	DB1-DB0	Read RED RAM Location	R1-R0 → DB1-DB0
1	0	1	DB9-DB2	Read GREEN RAM Location	G9-G2 → DB9-DB2
1	0	1	DB1-DB0	Read GREEN RAM Location	G1-G0 → DB1-DB0
1	0	1	DB9-DB2	Read BLUE RAM Location	B9-B2 → DB9-DB2
1	0	1	DB1-DB0	Read BLUE RAM Location (RAM Location Pointed to by Address Register (A7-A0)) Address Register = Address Register + 1	B1-B0 → DB1-DB0

*Writing or reading 10-bit data (DB9-DB0) over an 8-bit databus (D7-D0) requires two write or two read cycles.

:DB9-DB2 is mapped to D7-D0 on the first cycle.

:DB1-DB0 is mapped to D1-D0 on the second cycle.

DB = Data Bit.

ADV7150

Power-On Reset

On power-up of the ADV7150 executes a power-on reset operation. This initializes the pixel port such that the pixel sequence ABCD starts at A. The Mode Register (MR17–MR10), Command Register 2 (CR27–CR20) and Command Register 3 (CR37–CR30) have all bits set to a Logic “1.” Command Register 1 (CR17–CR10) has all bits set to a Logic “0.”

The output clocking signals are also set during this reset period.

$$\text{PRGCKOUT} = \text{CLOCK}/32$$

$$\text{LOADOUT} = \text{CLOCK}/4$$

The power-on reset is activated when V_{AA} goes from 0 V to 5 V. This reset is active for 1 μs . The ADV7150 should not be accessed during this reset period. The pixel clock should be applied at power-up.

REGISTER PROGRAMMING

The following section describes each register, including Address Register, Mode Register and each of the nine Control Registers in terms of its configuration.

Address Register (A7–A0)

As illustrated in the previous tables, the C0 and C1 control inputs, in conjunction with this address register specify which control register, or color palette location is accessed by the MPU port. The address register is 8-bits wide and can be read from as well as written to. When writing to or reading from the color palette on a sequential basis, only the start address needs to be written. After a red, green and blue write sequence, the address register is automatically incremented.

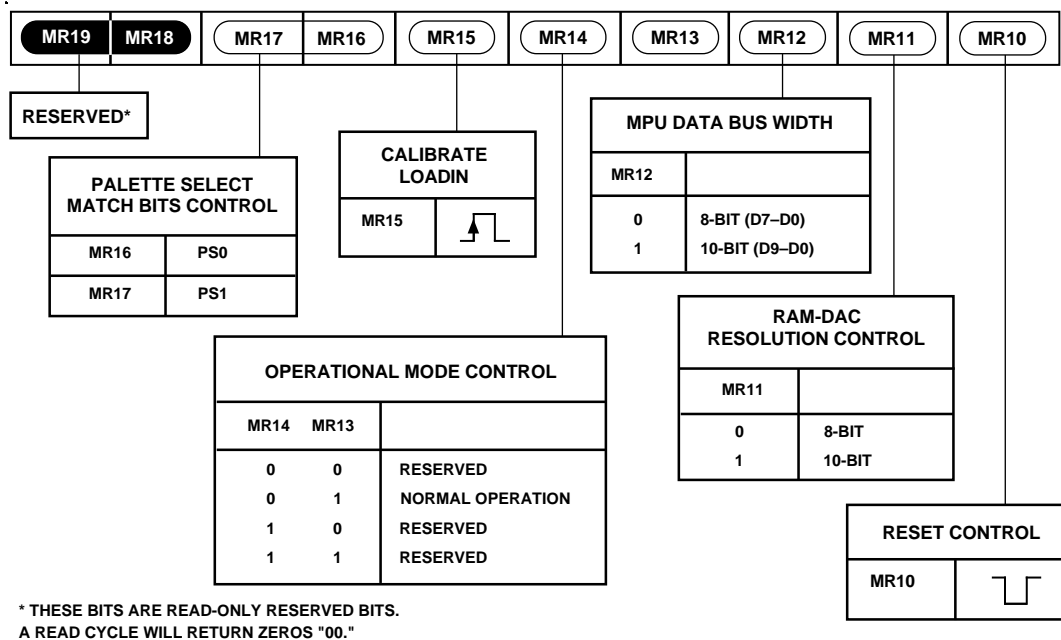

Mode Register 1 (MR1) (MR19–MR10)

MODE REGISTER MR1 (MR19–MR10)

The mode register is a 10-bit wide register. However for programming purposes, it may be considered as an 8-bit wide register (MR18 and MR19 are both reserved). It is denoted as MR17–MR10 for simplification purposes.

The diagram shows the various operations under the control of the mode register. This register can be read from as well written to. In read mode, if MR18 and MR19 are read back, they are both returned as zeros.

Mode Register (MR17–MR10) Bit Description

Reset Control (MR10)

This bit is used to reset the pixel port sampling sequence. This ensures that the pixel sequence ABCD starts at A. It is reset by writing a “1” followed by a “0” followed by a “1.” This bit must be run through this cycle during the initialization sequence.

RAM-DAC Resolution Control (MR11)

When this is programmed with a “1,” the RAM is 30 bits deep (10 bits each for red, green and blue) and each of the three DACs is configured for 10-bit resolution. When MR11 is

programmed with a “0,” the RAM is 24-bits deep (8 bits each for red, green and blue) and the DACs are configured for 8-bit resolution. The two LSBs of the 10-bit DACs are pulled down to zero in 8-bit RAM-DAC mode.

MPU Databus Width (MR12)

This bit determines the width of the MPU port. It is configured as either a 10-bit wide (D9–D0) or 8-bit wide (D7–D0) bus. 10-bit data can be written to the device when configured in 8-bit wide mode. The 8 MSBs are first written on D7–D0, then the two LSBs are written over D1–D0. Bits D9–D8 are zeros in 8-bit mode.

Operational Mode Control (MR14–MR13)

When MR14 is “0” and MR13 is “1,” the part operates in normal mode.

Calibrate LOADIN (MR15)

This bit automatically calibrates the onboard LOADIN/LOADOUT synchronization circuit. A “0” to “1” transition initiates calibration. This bit is set to “0” in normal operation. See “Pipeline Delay and Calibration” section. This bit must be run through this cycle during the initialization sequence.

Palette Select Match Bits Control (MR17–MR16)

These bits allow multiple palette devices to work together. When bits PS1 and PS0 match MR17 and MR16 respectively, the device is selected. If these bits do not match, the device is not selected and the analog video outputs drive 0 mA, see “Palette Priority Select Inputs” section.

CONTROL REGISTERS

The ADV7150 has 9 control registers. To access each register, two write operations must be performed. The first write to the address register specifies which of the 9 registers is to be accessed. The second access determines the value written to that particular control register.

Pixel Test Register

(Address Reg (A7–A0) = 00H)

This register is used when the device is in test/diagnostic mode. It is a 24-bit (8 bits each for RED, GREEN and BLUE) wide read-only register which allows the MPU to read data on the pixel port, see “Test Diagnostic” section.

DAC Test Register

(Address Reg (A7–A0) = 01H)

This register is used when the device is in test/diagnostic mode. It is a 30-bit (10 bits each for RED, GREEN and BLUE) wide read-only register which allows MPU access to the DAC port, see “Test Diagnostic” section.

SYNC, BLANK and I_{PLL} Test Register

(Address Reg (A7–A0) = 02H)

This register is used when the device is in test/diagnostic mode. It is a 3-bit wide (3 LSBs) read/write register which allows MPU access to these particular pixel control bits, see “Test Diagnostic” section.

ID Register

(Address Reg (A7–A0) = 03H)

This is an 8-bit wide “Identification” read-only register. For the ADV7150 it will always return the hexadecimal value 8EH.

Pixel Mask Register

(Address Reg (A7–A0) = 04H)

The contents of the pixel mask register are individually bit-wise logically AND-ed with the Red, Green and Blue pixel input stream of data. It is an 8-bit read/write register with D0 corresponding to R0, G0 and B0. For normal operation, this register is set with FFH.

COMMAND REGISTER 1 (CR1)

(Address Reg (A7–A0) = 05H)

This register contains a number of control bits as shown in the diagram. CR1 is a 10-bit wide register. However for programming purposes, it may be considered as an 8-bit wide register (CR18 to CR19 are reserved).

The diagram below shows the various operations under the control of CR1. This register can be read from as well as written to. In write mode, “0” should be written to CR11 and CR13 to CR17. In read mode, CR11 and CR13 to CR19 are returned as zeros.

COMMAND REGISTER 1-BIT DESCRIPTION

Calibration Control (CR10)

This bit automatically calibrates the onboard LOADIN/LOADOUT synchronization circuit. MR15 of Mode Register MR1 must be set to “0.”

SYNCOUT Control (CR12)

This bit specified whether the video SYNCOUT signal is to be enabled. On power up a “0” is written to the bit and “SYNCOUT” is set three-state.

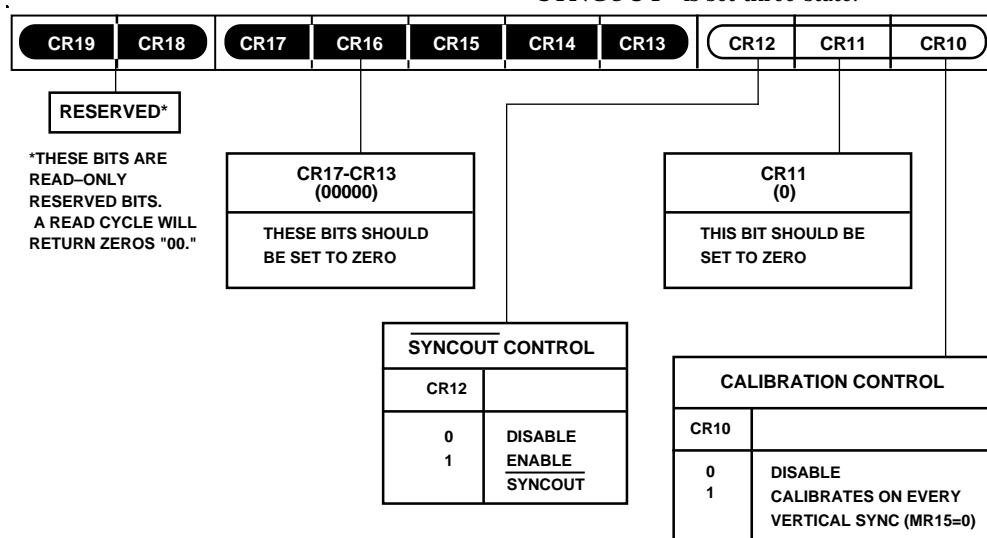

Command Register 1 (CR1) (CR19–CR10)

ADV7150

COMMAND REGISTER 2 (CR2)

(Address Reg (A7-A0) = 06H)

This register contains a number of control bits as shown in the diagram. CR2 is a 10-bit wide register. However, for programming purposes, it may be considered as an 8-bit wide register (CR28 and CR29 are both reserved).

The diagram shows the various operations under the control of CR2. This register can be read from as well written to. In read mode, CR28 and CR29 are both returned as zeros.

COMMAND REGISTER 2-BIT DESCRIPTION

R7 Trigger Polarity Control (CR20)

This bit is used when the device is in test/diagnostic mode. It determines whether the pixel data is latched into the test registers in the rising or falling edge of R7. (See "Test Diagnostics" section.)

I_{PLL} Trigger Control (CR21)

This bit specifies whether the I_{PLL} output is triggered from $\overline{\text{BLANK}}$ or $\overline{\text{SYNC}}$.

SYNC Recognition Control (CR22)

This bit specifies whether the video $\overline{\text{SYNC}}$ input is to be encoded onto the IOG analog output or ignored.

Pedestal Enable Control (CR23)

This bit specifies whether a 0 IRE or a 7.5 IRE blanking pedestal is to be generated on the video outputs.

True-Color/Pseudo-Color Mode Control (CR27-CR24)

These 4 bits specify the various color modes. These include a 24-bit true-color mode, two 15-bit true-color modes and three 8-bit pseudo color modes.

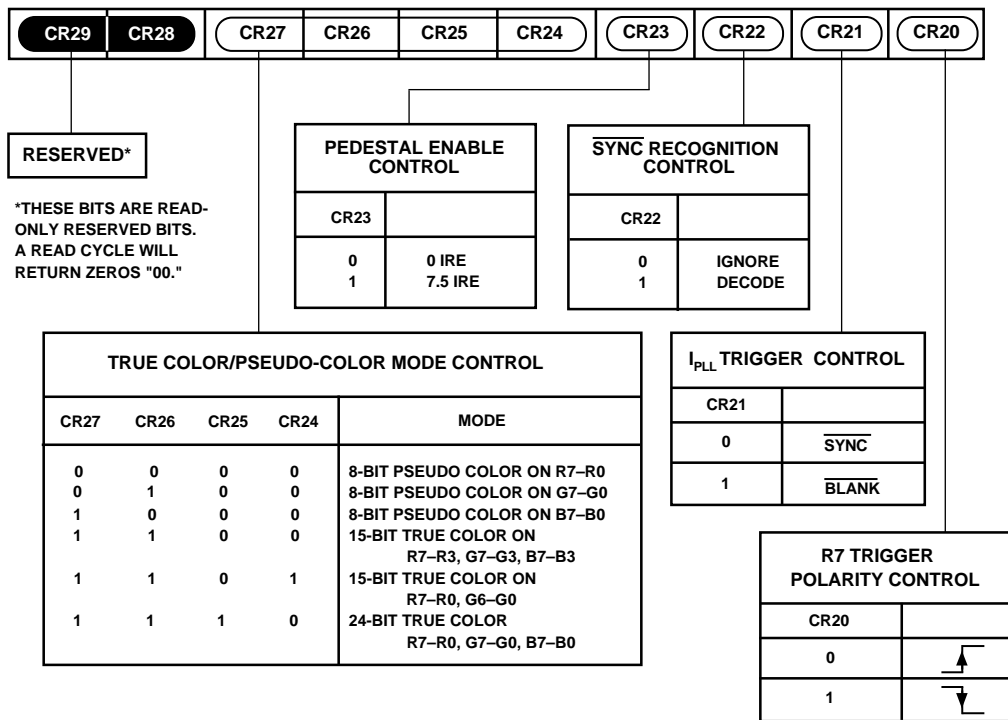

Command Register 2 (CR2) (CR29-CR20)

COMMAND REGISTER 3 (CR3)

(Address Reg (A7-A0) = 07H)

This register contains a number of control bits as shown in the diagram. CR3 is a 10-bit wide register. However for programming purposes, it may be considered as an 8-bit wide register (CR38 and CR39 are both reserved).

The diagram shows the various operations under the control of CR3. This register can be read from as well written to. In read mode, CR38 and CR39 are both returned as zeros.

COMMAND REGISTER 3-BIT DESCRIPTION

PRGCKOUT Frequency Control (CR31-CR30)

These bits specify the output frequency of the PRGCKOUT output. PRGCKOUT is a divided down version of the pixel CLOCK.

BLANK Pipeline Delay Control (CR35-CR32)

These bits specify the additional pipeline delay that can be added to the $\overline{\text{BLANK}}$ function, relative to the overall device pipeline delay (t_{PD}). As the $\overline{\text{BLANK}}$ control normally enters the video DAC from a shorter pipeline than the video pixel data, this control is useful in deskewing the pipeline differential.

Pixel Multiplex Control (CR37-CR36)

These bits specify the device's multiplex mode. It, therefore, also determines the frequency of the LOADOUT signal. LOADOUT is a divided down version of the pixel CLOCK.

Revision Register

(Address Reg (A7-A0) = 0BH)

This register is a read only register containing the revision of silicon.

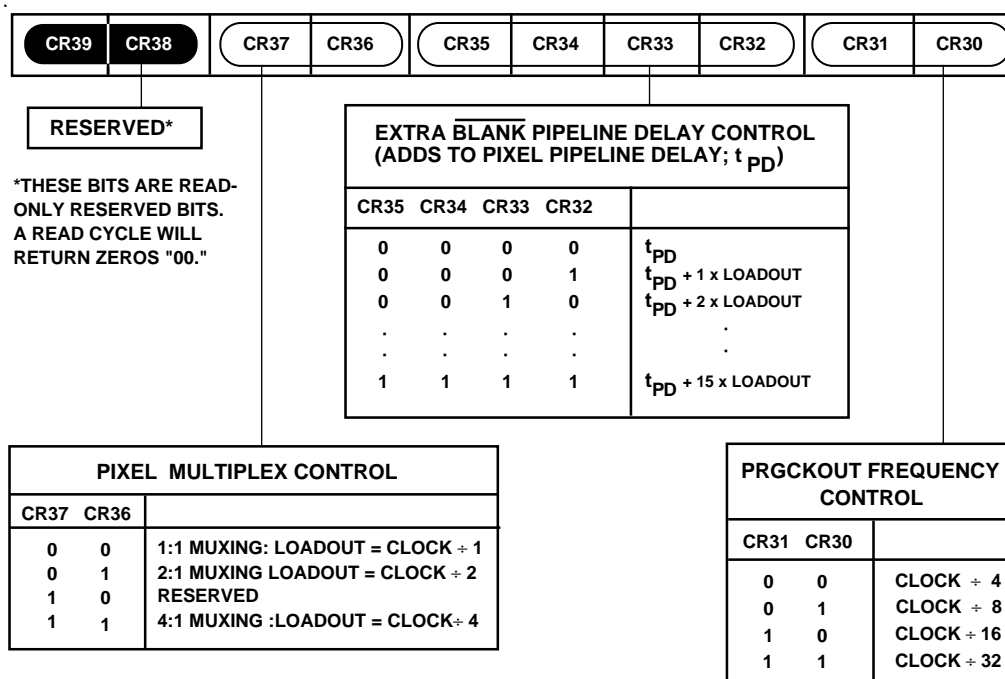

Command Register 3 (CR3) (CR39-CR30)

ADV7150

DIGITAL-TO-ANALOG CONVERTERS (DACs) AND VIDEO OUTPUTS

The ADV7150 contains three high speed video DACs. The DAC outputs are represented as the three primary analog color signals IOR (red video), IOG (green video) and IOB (blue video). Other analog signals on the part include I_{PLL} and V_{REF} as well as complementary video outputs \overline{IOR} , \overline{IOG} , \overline{IOB} . These complementary outputs can be used to drive differentially terminated video loads, they will have equal but opposite output levels to IOR, IOG and IOB when loaded with a resistive load similar to IOR, IOG and IOB.

DACs and Analog Outputs

The part contains three matched 10-bit digital-to-analog converters. The DACs are designed using an advanced, high speed, segmented architecture. The bit currents corresponding to each digital input are routed to either IOR, IOG, IOB (bit = "1") or \overline{IOR} , \overline{IOG} , \overline{IOB} (bit = "0"). (Normally \overline{IOR} , \overline{IOG} , \overline{IOB} = GND.)

The analog video outputs are high impedance current sources. Each of these three RGB current outputs are specified to directly drive a $37.5\ \Omega$ load (doubly terminated $75\ \Omega$).

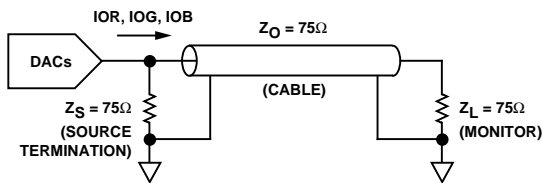

Figure 29. DAC Output Termination (Doubly Terminated $75\ \Omega$ Load)

Reference Input and R_{SET}

An external $1.23\ V$ voltage reference is required to drive the analog outputs of the ADV7150. The reference voltage is connected to the V_{REF} input.

A resistor R_{SET} is connected between the R_{SET} input of the part and ground. For specified performance, R_{SET} has a value of $280\ \Omega$. This corresponds to the generation of RS-343A video levels (with \overline{SYNC} on IOG and Pedestal = 7.5 IRE) into a doubly terminated $75\ \Omega$ load. Figure 30 illustrates the resulting video waveform, and the Video Output Truth Table shows the corresponding control input stimuli.

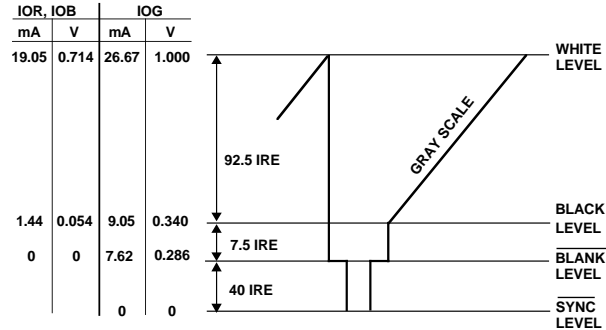

Figure 30. Composite Video Waveform (\overline{SYNC} Decoded on IOG; Pedestal = 7.5 IRE; $R_{SET} = 280\ \Omega$)

Variations on RS-343A

Various other video output configurations can be implemented by the ADV7150, including RS-170. Values of R_{SET} for particular output video formats/levels are calculated by using the equations for R_{SET} given in the "Pin Configuration" section. The table shows calculated values of R_{SET} for some of the most common variants on the RS-343A standard. The associated waveforms are shown in the diagrams.

Table V. Video Output Truth Table

Description	IOG (mA)	IOR, IOB (mA)	\overline{SYNC}	\overline{BLANK}	DAC Input Data
WHITE LEVEL VIDEO	26.67	19.05	1	1	3FFH
VIDEO to \overline{BLANK}	Video + 9.05	Video + 1.44	1	1	Data
\overline{BLANK} LEVEL	Video + 1.44	Video + 1.44	0	1	Data
BLACK LEVEL	9.05	1.44	1	1	000H
BLACK to \overline{BLANK}	1.44	1.44	0	1	000H
\overline{BLANK} LEVEL	7.62	0	1	0	xxxH
\overline{SYNC} LEVEL	0	0	0	0	xxxH

Decoded on IOG; Pedestal = 0 IRE; $R_{SET} = 265\ \Omega$.

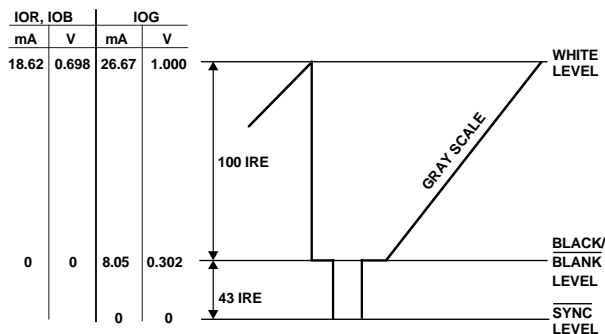

Figure 31. Composite Video Waveform SYNC

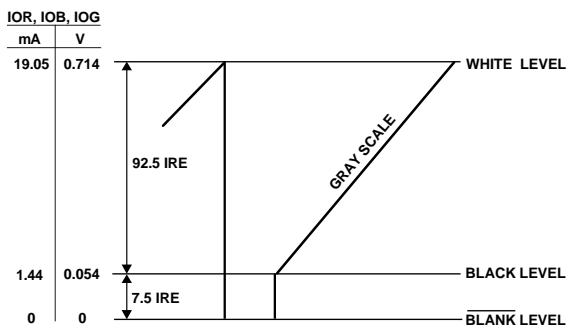

Figure 32. Composite Video Waveform (Pedestal = 7.5 IRE; $R_{SET} = 280 \Omega$)

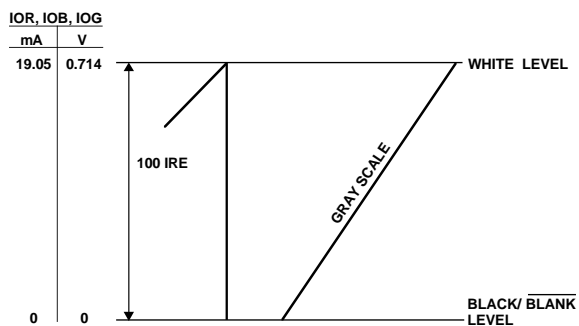

Figure 33. Composite Video Waveform (Pedestal = 0 IRE; $R_{SET} = 259 \Omega$)

$R_{SET} (\Omega)$	Video Signal
265	$\overline{\text{SYNC}}$ decoded on IOG; Pedestal = 0 IRE
280	No $\overline{\text{SYNC}}$ decoded; Pedestal = 7.5 IRE
259	No $\overline{\text{SYNC}}$ decoded; Pedestal = 0 IRE

I_{PLL} Synchronization Output Control

This output synchronization signal is used in applications where it is necessary to synchronize multiple palette devices (ADV7150 + ADV7151) to subpixel resolution. Each device's I_{PLL} output signal is in phase with its analog RGB output signal. If multiple devices have differing output delays, the time difference can be derived from the I_{PLL} signals. This time difference is then used to phase shift the CLOCK inputs on one or other of the devices inputs.

The I_{PLL} signal is internally triggered by either the falling edge of SYNC or BLANK as determined by CR21 of Command Register 2.

APPENDIX 1

BOARD DESIGN AND LAYOUT CONSIDERATIONS

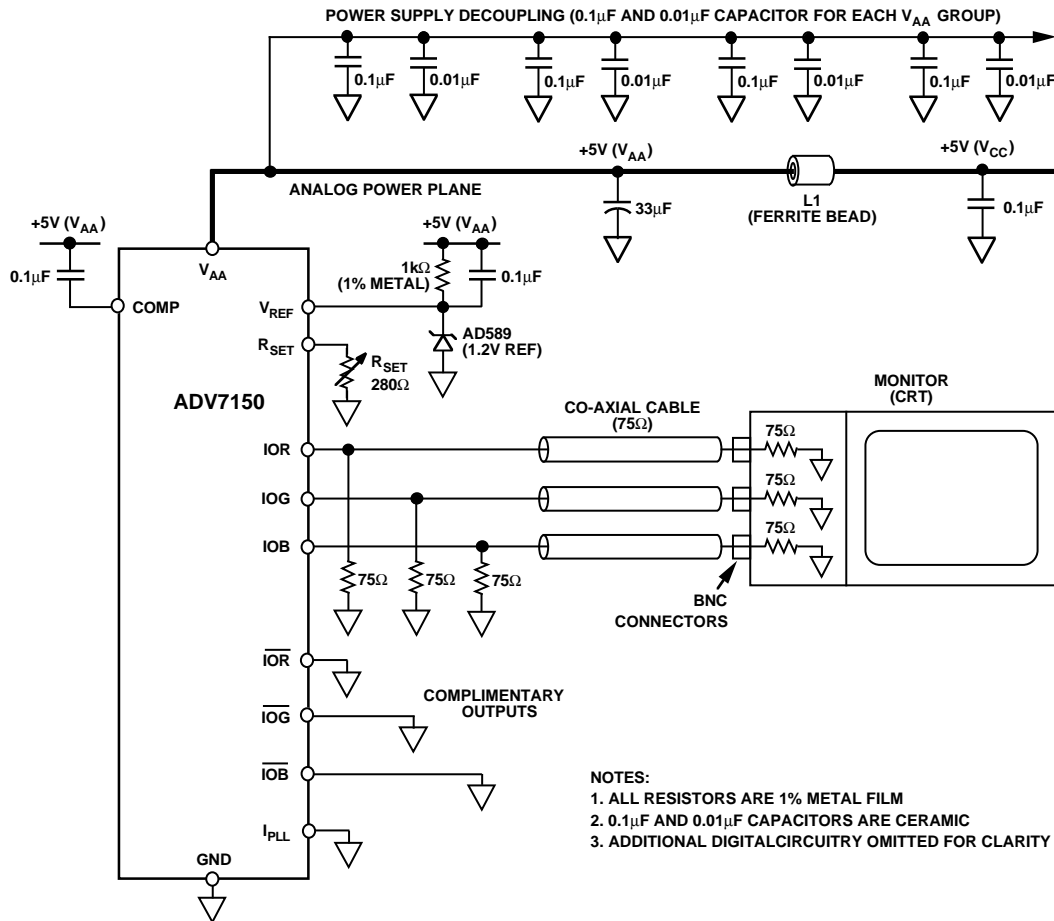

Recommended Analog Circuit Layout

The ADV7150 is a highly integrated circuit containing both precision analog and high speed digital circuitry. It has been designed to minimize interference effects on the integrity of the analog circuitry by the high speed digital circuitry. It is imperative that these same design and layout techniques be applied to the system level design such that high speed, accurate performance is achieved. The “Recommended Analog Circuit Layout” shows the analog interface between the device and monitor.

The layout should be optimized for lowest noise on the ADV7150 power and ground lines by shielding the digital inputs and providing good decoupling. The lead length between groups of V_{AA} and GND pins should be minimized so as to minimize inductive ringing.

Ground Planes

The ground plane should encompass all ADV7150 ground pins, voltage reference circuitry, power supply bypass circuitry for the ADV7150, the analog output traces, and all the digital signal traces leading up to the ADV7150. The ground plane is the graphics board’s common ground plane.

Power Planes

The ADV7150 and any associated analog circuitry should have its own power plane, referred to as the analog power plane (V_{AA}). This power plane should be connected to the regular PCB

power plane (V_{CC}) at a single point through a ferrite bead. This bead should be located within three inches of the ADV7150.

The PCB power plane should provide power to all digital logic on the PC board, and the analog power plane should provide power to all ADV7150 power pins and voltage reference circuitry.

Plane-to-plane noise coupling can be reduced by ensuring that portions of the regular PCB power and ground planes do not overlay portions of the analog power plane, unless they can be arranged such that the plane-to-plane noise is common mode.

Supply Decoupling

For optimum performance, bypass capacitors should be installed using the shortest leads possible, consistent with reliable operation, to reduce the lead inductance. Best performance is obtained with 0.1 µF ceramic capacitor decoupling. Each group of V_{AA} pins on the ADV7150 must have at least one 0.1 µF decoupling capacitor to GND. These capacitors should be placed as close as possible to the device.

It is important to note that while the ADV7150 contains circuitry to reject power supply noise, this rejection decreases with frequency. If a high frequency switching power supply is used, the designer should pay close attention to reducing power supply noise and consider using a three terminal voltage regulator for supplying power to the analog power plane.

Digital Signal Interconnect

The digital inputs to the ADV7150 should be isolated as much as possible from the analog outputs and other analog circuitry. Also, these input signals should not overlay the analog power plane.

Due to the high clock rates involved, long clock lines to the ADV7150 should be avoided to reduce noise pickup.

Any active termination resistors for the digital inputs should be connected to the regular PCB power plane (V_{CC}), and not the analog power plane.

Analog Signal Interconnect

The ADV7150 should be located as close as possible to the output connectors to minimize noise pick-up and reflections due to impedance mismatch.

The video output signals should overlay the ground plane, and not the analog power plane, to maximize the high frequency power supply rejection.

Digital Inputs, especially Pixel Data Inputs and clocking signals (CLOCK, LOADOUT, LOADIN, etc.) should never overlay any of the analog signal circuitry and should be kept as far away as possible.

For best performance, the analog outputs (IOR, IOG, IOB) should each have a $75\ \Omega$ load resistor connected to GND. These resistors should be placed as close as possible to the ADV7150 so as to minimize reflections. Normally, the differential analog outputs (\overline{IOR} , \overline{IOG} , \overline{IOB}) are connected directly to GND. In some applications, improvements in performance are achieved by terminating these differential outputs with a resistive load similar in value to the video load. For a doubly terminated $75\ \Omega$ load, this means that \overline{IOR} , \overline{IOG} , \overline{IOB} are each terminated with $37.5\ \Omega$ resistors.

APPENDIX 2

TYPICAL FRAME BUFFER INTERFACE

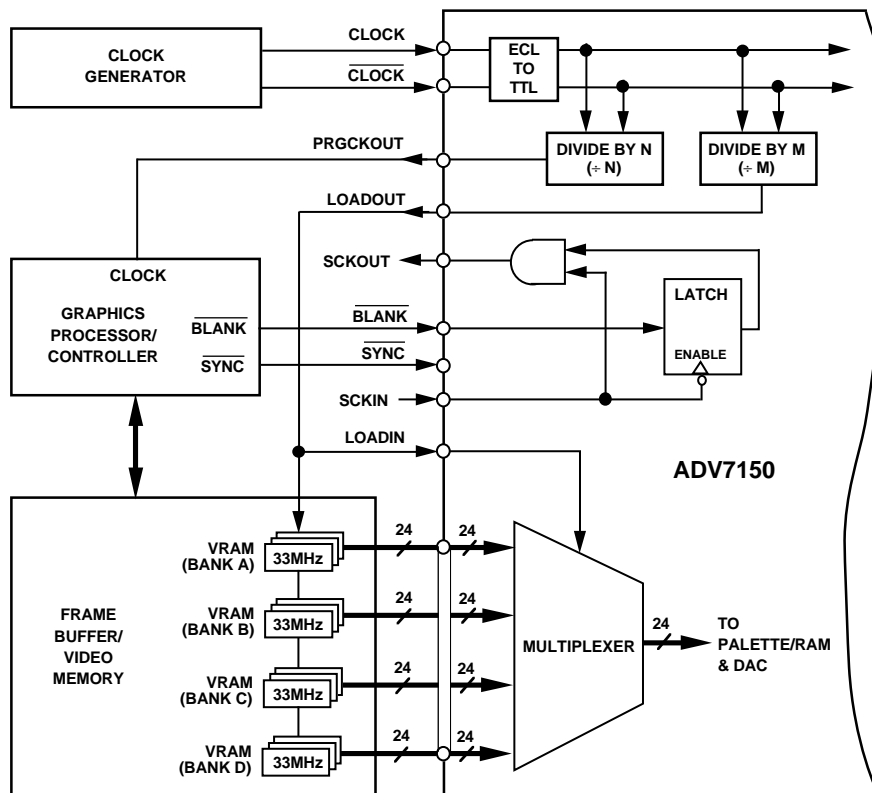

APPENDIX 3

10-BIT DACS AND GAMMA CORRECTION

10-Bit DACs

10-Bit RAM-DAC resolution allows for nonlinear video correction, in particular Gamma Correction. The ADV7150 allows for an increase in color resolution from 24-bit to 30-bit effective color without the necessity of a 30-bit deep frame buffer. In true-color mode, for example, the part effectively operates as a 24-bit to 30-bit color look-up table.

Up to now we have assumed that there exists a linear relationship between the actual RGB values input to a monitor and the intensity produced on the screen. This, however, is not the case. Half scale digital input (1000 0000) might correspond to only 20% output intensity on the CRT (Cathode Ray Tube). The intensity (I_{CRT}) produced on a CRT by an input value I_{IN} is given by:

$$I_{CRT} = (I_{IN})^\chi$$

where χ ranges from 2.0 to 2.8.

If the individual values of χ for red, green and blue are known, then so called "Gamma Correction" can be applied to each of the three video input signals (I_{IN});

therefore:

$$I_{IN(corrected)} = k(I_{IN})^{1/\chi} \quad (k = 1, \text{ normally})$$

Traditionally, there has been a tradeoff between implementing a nonlinear graphics function, such as gamma correction, and color dynamic range. The ADV7150 overcomes this by increasing the individual color resolution of each of the red, green and blue primary colors from 8 bits per color channel to 10 bits per channel (24 bits to 30 bits).

The table highlights the loss of resolution when 8-bit data is gamma-corrected to a value of 2.7 and quantized in a traditional 8-bit system. Note that there is no change in the 8-bit quantized data for linear changes in the input data over much of the transfer function. On the other hand, when quantized to 10 bits via the 10-bit RAMs and 10-bit DACs of the ADV7150, all changes on the input 8-bit data are reflected in corresponding changes in the 10-bit data.

The graph shows a typical gamma curve corresponding to a gamma value of 2.7. This is programmed to the red, green and blue RAMs of the color lookup table instead of the more traditional linear function. Different curves corresponding to any particular gamma value can be independently programmed to each of the red, green and blue RAMs.

Other applications of the 10-bit RAM-DAC include closed-loop monitor color calibration.

Gamma Correction 8 Bits vs. 10 Bits

8-Bit Data	Gamma Corrected (2.7)	Quantized to 8 Bits	Quantized to 10 Bits
240	0.977797	250	1001
241	0.979304	250	1002
242	0.980807	251	1004
243	0.982306	251	1005
244	0.983801	251	1007
245	0.985292	252	1008
246	0.986780	252	1010
247	0.988264	252	1011
248	0.989744	253	1013
249	0.991220	253	1015
250	0.992693	254	1016
251	0.994161	254	1018
252	0.995626	254	1019
253	0.997088	255	1021
254	0.998546	255	1022
255	1.000000	255	1023

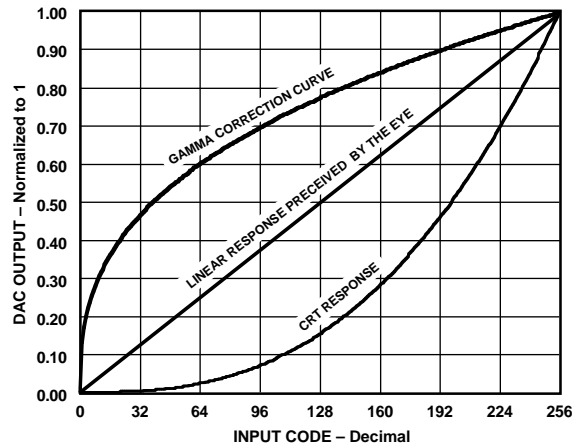

Gamma Correction Curve (Gamma Value = 2.7)

APPENDIX 4

MULTIPLE PALETTE APPLICATIONS

Palette Priority Select Inputs

The palette priority selection inputs allow up to four separate palette devices to be used in a single system to drive a single monitor with subpixel resolution. The IOR, IOG and IOB analog video output signals of each device are connected together, as shown. Signal inputs (PS0, PS1) determine on a pixel by pixel basis which palette device drives the monitor. This allows for implementation of multiple windows applications with each device acting as an independent palette. During initialization, each device is assigned two match bits, MR16 (PS0) and MR17 (PS1) in Mode Register MR1. PS0 and PS1 inputs will select one of the preprogrammed devices at any instant when PS0, PS1 matches MR16, MR17, respectively. PS0 and PS1 are multiplexed similar to the pixel data, thus allowing for subpixel resolution. The diagrams show an example of one ADV7150 operating in

conjunction with three ADV7151's (Pseudo-Color RAM-DACs). Each displayed window on the monitor is driven by one of the four devices, as determined on a pixel basis by PS0, PS1. Each device's analog output signals are connected together as shown.

Note: Only one palette device is selected at any particular instant. The analog output levels of the unselected devices will be 0 mA.

Other applications for the palette priority function using a minimum of two devices (one ADV7150 and one ADV7151) include:

- Cursor Overlay on 24-Bit Graphics
- Active Live Video Overlay (from Frame Grabber)
- Text/Character Generation and Overlay

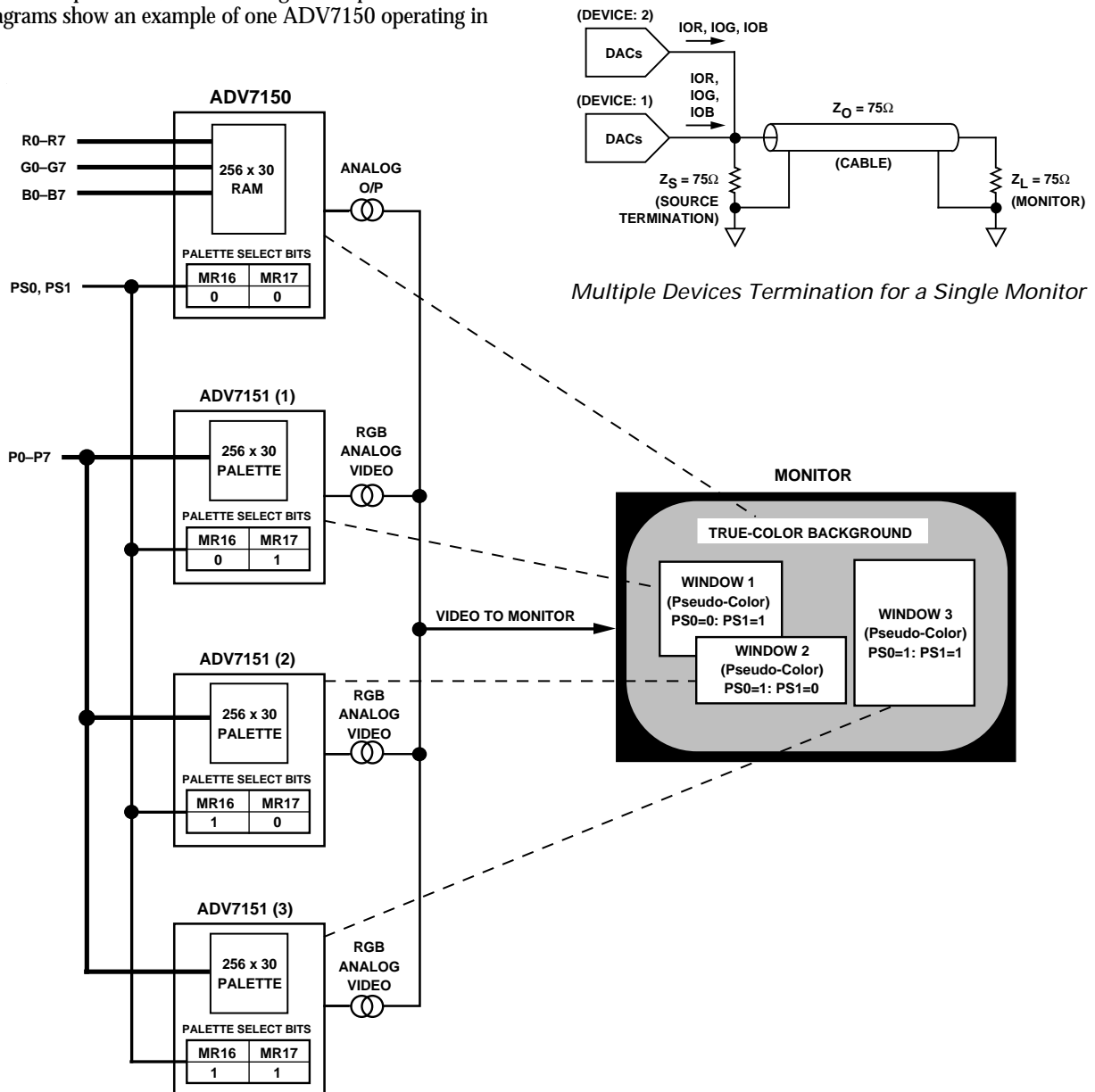

Multiple Devices Termination for a Single Monitor

Multiple Devices Driving a Multiwindow Application

APPENDIX 5

INITIALIZATION AND PROGRAMMING

ADV7150 Initialization

After power has been supplied, the ADV7150 must be initialized. The Mode Register and Control Registers must be set. The values written to the various registers will be determined by the desired operating mode of the part, i.e., True Color/Pseudo Color, 2:1 Muxing/2:1 Muxing, etc.

The following section gives examples of initialization of the ADV7150 operating in various modes.

Example 1

Color Mode 24-Bit True Color
Multiplexing 2:1
Databus 8-Bit
RAM-DAC Resolution 8-Bit
SYNC Enabled on IOG
Pedestal 7.5 IRE

Register Initialization

	C1	C0	R/W	Comment
Write 09H to Mode Register (MR1)	1	1	0	Resets to Normal Operation, 8-Bit Bus/RAM-DAC
Write 08H to Mode Register (MR1)	1	1	0	*(Initializes Pipelining
Write 09H to Mode Register (MR1)	1	1	0	*(“
Write 29H to Mode Register (MR1)	1	1	0	*(Calibrates LOADOUT/LOADIN Timing
Write 09H to Mode Register (MR1)	1	1	0	*(“
Write 04H to Address Register (A7-A0)	0	0	0	Address Reg Points to Pixel Mask Register
Write FFH to Pixel Mask Register	1	0	0	Sets the Pixel Mask to All “1s”
Write 05H to Address Register (A7-A0)	0	0	0	Address Reg Points to Command Register 1 (CR1)
Write 00H to Command Reg 1 (CR1)	1	0	0	
Write 06H to Address Register (A7-A0)	0	0	0	Address Reg Points to Command Register 2 (CR2)
Write ECH to Command Reg 2 (CR2)	1	0	0	Sets 24-Bit Color, 7.5 IRE, SYNC on Green (IOG)
Write 07H to Address Register (A7-A0)	0	0	0	Address Reg Points to Command Register 3 (CR3)
Write C0H to Command Reg 3 (CR3)	1	0	0	Sets 2:1 Multiplexing, PRGCKOUT = CLOCK/4

Color Palette RAM Initialization

	C1	C0	R/W	Comment
Write 00H to Address Register (A7-A0)	0	0	0	Points to Color Palette RAM
Write 00H (Red Data) to RAM Location (00H)	0	1	0	(Initializes Palette RAM
Write 00H (Green Data) to RAM Location (00H)	0	1	0	(to a Linear Ramp**
Write 00H (Blue Data) to RAM Location (00H)	0	1	0	(
Write 01H (Red Data) to RAM Location (01H)	0	1	0	(
Write 01H (Green Data) to RAM Location (01H)	0	1	0	(
Write 01H (Blue Data) to RAM Location (01H)	0	1	0	(
• • • • •	•	•	•	(
• • • • •	•	•	•	(
Write FFH (Red Data) to RAM Location (FFH)	0	1	0	(
Write FFH (Green Data) to RAM Location (FFH)	0	1	0	(
Write FFH (Blue Data) to RAM Location (FFH)	0	1	0	(RAM Initialization Complete

*These four command lines reset the ADV7150. The pipelines for each of the Red, Green and Blue pixel inputs are synchronously reset to the Multiplexer's "A" input. Mode Register bit MR10 is written by a "1" followed by "0" followed by "1." LOADIN/LOADOUT timing is internally synchronized by writing a "0" followed by a "1" followed by a "0" to Mode Register MR15.

**This sequence of instructions would, of course, normally be coded using some form of loop instruction.

Example 2

<i>Color Mode</i>	<i>24-Bit Gamma Corrected True Color (30 Bits)</i>
<i>Multiplexing</i>	<i>2:1</i>
<i>Databus</i>	<i>10 Bit</i>
<i>RAM-DAC Resolution</i>	<i>10 Bit</i>
<i>SYNC</i>	<i>Ignored</i>
<i>Pedestal</i>	<i>0 IRE</i>
<i>Calibration</i>	<i>Every Vertical Sync</i>

Register Initialization	C1	C0	R/W	Comment
Write 0FH to Mode Register (MR1)	1	1	0	Resets to Normal Operation, 10-Bit Bus/RAM-DAC
Write 0EH to Mode Register (MR1)	1	1	0	*(Initializes Pipelining
Write 0FH to Mode Register (MR1)	1	1	0	*(“
Write 2FH to Mode Register (MR1)	1	1	0	*(Calibrates LOADOUT/LOADIN Timing
Write 0FH to Mode Register (MR1)	1	1	0	*(“
Write 04H to Address Register (A7-A0)	0	0	0	Address Reg Points to Pixel Mask Register
Write FFH to Pixel Mask Register	1	0	0	Sets the Pixel Mask to All “1s”
Write 05H to Address Register (A7-A0)	0	0	0	Address Reg Points to Command Register 1 (CR1)
Write 01H to Command Reg 1 (CR1)	0	0	0	Calibrates Every Vertical Sync
Write 06H to Address Register (A7-A0)	0	0	0	Address Reg Points to Command Register 2 (CR2)
Write E0H to Command Reg 2 (CR2)	1	0	0	Sets 24-Bit Color, 0 IRE, No SYNC
Write 07H to Address Register (A7-A0)	0	0	0	Address Reg Points to Command Register 3 (CR3)
Write 41H to Command Reg 3 (CR3)	1	0	0	Sets 2:1 Multiplexing, PRGCKOUT = $\overline{\text{CLOCK}}/8$
Color Palette RAM Initialization	C1	C0	R/W	Comment
Write 00H to Address Register (A7-A0)	0	0	0	Points to Color Palette RAM
Write 000H (Red Data) to RAM Location (00H)	0	1	0	(Initializes Palette RAM
Write 000H (Green Data) to RAM Location (00H)	0	1	0	(to a “Gamma” Ramp**
Write 000H (Blue Data) to RAM Location (00H)	0	1	0	(
Write xxxH (Red Data) to RAM Location (01H)	0	1	0	(
Write xxxH (Green Data) to RAM Location (01H)	0	1	0	(
Write xxxH (Blue Data) to RAM Location (01H)	0	1	0	(
• • • • •	•	•	•	(
• • • • •	•	•	•	(
Write 3FFH (Red Data) to RAM Location (FFH)	0	1	0	(
Write 3FFH (Green Data) to RAM Location (FFH)	0	1	0	(
Write 3FFH (Blue Data) to RAM Location (FFH)	0	1	0	(RAM Initialization Complete

*These four command lines reset the ADV7150 The pipelines for each of the Red, Green and Blue pixel inputs are synchronously reset to the Multiplexer’s “A” input. Mode Register bit MR10 is written by a “1” followed by “0” followed by “1.” LOADIN/LOADOUT timing is internally synchronized by writing a “0” followed by a “1” followed by a “0” to Mode Register MR15.

**Data for a gamma curve characteristic is obtainable in Appendix 3.

REGISTER DIAGNOSTIC TESTING

The previous examples show the register initialization sequence for the ADV7150. These show control data going to the registers and palette RAM. As well as this writing function, it may also be necessary, due to system diagnostic requirements, to confirm that correct data has been transferred to each register and palette RAM location. There are two ways to incorporate register value/RAM value checking:

1. *READ after each WRITE:* After data is written to a particular register, it can be read back immediately. The following table shows an example with Command Registers CR2 and CR3.

C1	C0	R/W	D0-D7	Comment
0	0	0	06H	Select Command Register 2 (CR2)
1	0	0	E0H	Sets 24-Bit True-Color
1	0	1	E0H	Command Reg 2 Value Read-Back
0	0	0	07H	Select Command Register 3 (CR3)
1	0	0	40H	Set 2:1 Mux Mode
1	0	1	40H	Command Reg 3 Value Read-Back

2. *READ after all WRITES completed:* All registers and the color palette RAM are written to and set. Once this is complete, all registers are again accessed but this time in Read-Only mode. The table below shows this method for Command Registers CR2 and CR3.

C1	C0	R/W	D0-D7	Comment
0	0	0	06H	Select Command Register 2 (CR2)
1	0	0	E0H	Sets 24-Bit True-Color
0	0	0	07H	Select Command Register 3 (CR3)
1	0	0	40H	Set 2:1 Mux Mode
0	0	0	06H	Select CR2
1	0	1	E0H	CR2 Value Read-Back
0	0	0	07H	Select CR3
1	0	1	40H	CR3 Value Read-Back
1	0	1	40H	CR3 Value Read-Back

It is clear that this latter case requires more command lines than the previous READ after each WRITE case.

APPENDIX 6
TEST DIAGNOSTICS

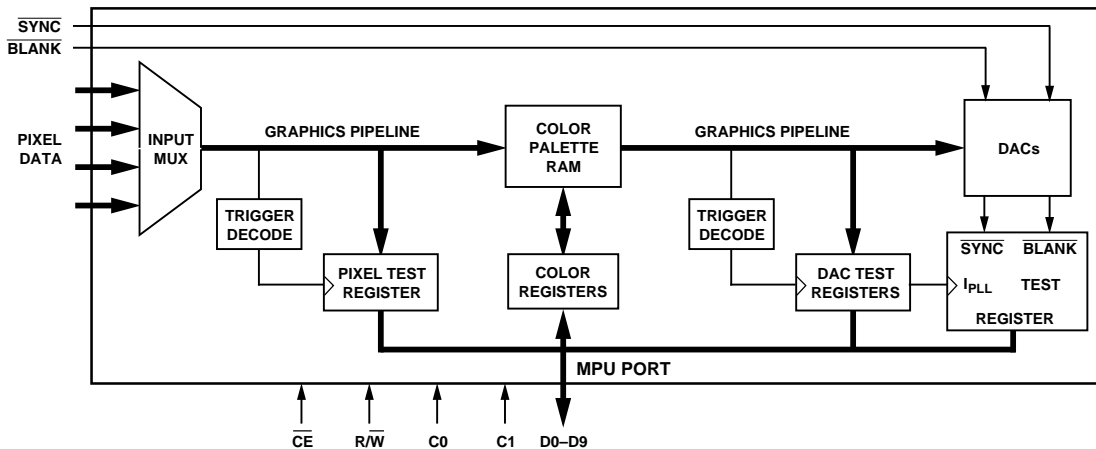

Test/Diagnostic Block Diagram

The ADV7150 contains onboard circuitry which enables both device and system level test diagnostics. The test circuitry can be used to test the frame buffer memory as well as the functionality of the ADV7150. A number of test registers are integrated into the part which effectively allow for monitoring of the graphics pipeline. Pixel data is read from the graphics pipeline independent of the pixel CLOCK. The pixel data itself contains the triggering information that latches data into the test registers. This allows for system diagnostics in a continuously clocked graphics system. The test register data is then read by the microprocessor over the MPU.

Access to the test registers is as described in the “Microprocessor (MPU) Port” section. This section also gives the address decode locations for the various test registers.

Test Trigger (R7)

The test trigger is decoded from the pixel data stream. Bit R7 of the RED channel is assigned the task of latching pixel data into the test registers. A “0” to “1” or a “1” to “0” (as determined by bit CR20 of Command Register 2) transition on R7, fills the test register with the corresponding pixel data. This effectively means that a sequence of data travels along the graphics pipeline, with the test registers taking a sample only when there is a transition on Bit R7. The following example shows a sequence with the ADV7150 preset to sample the graphics pipeline on a low to high transition of R7.

	RED	GREEN	BLUE
Pixel 0:	00000000	00000000	00000000
Pixel 1:	0.....
Pixel 2:	1.....
Pixel 3:	0.....
...
Pixel n-1:	0.....
Pixel n:	1.....
Pixel n:	0.....

In the above sequence of pixels, there is a rising edge on R7 on Pixel 2. The Red, Green and Blue data for Pixel 2, therefore, gets latched into the Pixel Test Register. Pixel 2 continues down

the graphics pipeline and after a number of clocks get latched into the DAC Test Register. This data can then be read from the Pixel Test Register and the DAC Test Registers over the MPU Port. This data will remain in the Pixel Test Registers and the DAC Test Registers until the next rising edge of R7 causes new data to be latched in.

In the above example, the next rising edge of R7 occurs on the Pixel *n* input. Therefore the data in the Pixel Test Registers and DAC Test Registers must be read over the MPU before the Pixel *n* data is applied, otherwise they will be overwritten by the Pixel *n* data and the Pixel 2 data will be lost.

Pixel Test Register

The read-only Pixel Test Register is 24 bits wide, 8 bits each for red green and blue. It is situated directly after the Pixel Mask Register. After data is latched into this register by a transition on R7, it is read in three cycles over the MPU Port as described in the “Microprocessor (MPU) Port” section.

DAC Test Register

The DAC Test Register is latched with data some CLOCKS after the Pixel Test Register. The DAC Test Register is a 30-bit wide read-only register, corresponding to 10 bits each for red, green and blue data. It is located the Color Palette RAM. If the RAM-DAC is in 8-bit after resolution mode, the upper two bits of the red, green and blue data will be zero. After data is latched into the DAC Test Register by a transition on R7, it is read in three or six cycles over the MPU Port as described in the “Microprocessor (MPU) Port” section.

SYNC, BLANK and I_{PLL} Test Register

This is an 8-bit wide register but with only three effective bits. The three lower bits correspond to SYNC, BLANK and I_{PLL} respectively. The upper bits should be masked in software. This register is at the same position in the graphics pipeline as the DAC Test Register. When pixel data is latched into the DAC Test Register, the corresponding status of SYNC, BLANK and I_{PLL} is latched into this register. It is read over the MPU Port as described in the “Microprocessor (MPU) Port” section.

(Note: If BLANK is low, the corresponding pixel data to the DAC Test Register will be all “0s.”)

APPENDIX 7

THERMAL AND ENVIRONMENTAL CONSIDERATIONS

The ADV7150 is a very highly integrated monolithic silicon device. This high level of integration, in such a small package, inevitably leads to consideration of thermal and environmental conditions in which the ADV7150 must operate. Reliability of the device is significantly enhanced by keeping it as cool as possible. In order to avoid destructive damage to the device, the absolute maximum junction temperature of 150°C must never be exceeded. Certain applications, depending on pixel data rates, may require forced air cooling, or external heatsinks. The following data is intended as a guide in evaluating the operating conditions of a particular application so that optimum device and system performance is achieved.

It should be noted that information on package characteristics published herein may not be the most up to date at the time of reading this. Advances in package compounds and manufacture will inevitably lead to improvements in the thermal data. Please contact your local sales office for the most up-to-date information.

Power Dissipation

The diagram shows graphs of power dissipation in watts vs. pixel clock frequency for the ADV7150.

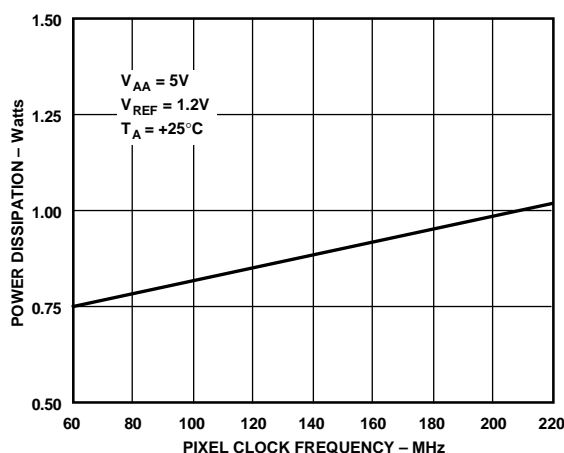

NOTE: THE "WORST CASE ON-SCREEN PATTERN" CORRESPONDS TO FULL-SCALE TRANSITION ON EACH PIXEL VALUE FOR EVERY CLOCK EDGE (00H, FFH, 00H, ...). THE "TYPICAL ON-SCREEN PATTERN" CORRESPONDS TO LINEAR CHANGES IN THE PIXEL INPUT (I. E., A BLACK TO WHITE RAMP). IN GENERAL, COLOR IMAGES TEND TO APPROXIMATE THIS CHARACTERISTIC.

Typical Power Dissipation vs. Pixel Rate

Package Characteristics

The table of thermal characteristics shows typical information for the ADV7150 (160-Lead Plastic Power QFP) using various values of Airflow.

Junction to Case (θ_{JC}) Thermal Resistance for this particular part is:

$$\theta_{JC} \text{ (160-Lead Plastic Power QFP)} = 1.0^\circ\text{C/W}$$

(Note: θ_{JC} is independent of airflow.)

Table A. Thermal Characteristics vs. Airflow

Air Velocity (Linear feet/min)	0 (Still Air)	50	100	200
θ_{JA} ($^\circ\text{C/W}$)				
No Heatsink	25.5	23	21	19
EG&G D10100-28 Heatsink	23	20	18	16
Thermalloy 2290 Heatsink	19	17	15	12

Thermal Model

The junction temperature of the device in a specific application is given by:

$$T_J = T_A + P_D (\theta_{JC} + \theta_{CA}) \quad (1)$$

or

$$T_J = T_A + P_D (\theta_{JA}) \quad (2)$$

where:

T_J = Junction Temperature of Silicon ($^\circ\text{C}$)

T_A = Ambient Temperature ($^\circ\text{C}$)

P_D = Power Dissipation (W)

θ_{JC} = Junction to Case Thermal Resistance ($^\circ\text{C/W}$)

θ_{CA} = Case to Ambient Thermal Resistance ($^\circ\text{C/W}$)

θ_{JA} = Junction to Ambient Thermal Resistance ($^\circ\text{C/W}$)

Package Enhancements

The standard QFP package has been enhanced to a PowerQuad2 package. This supports an improved thermal performance compared to standard QFP. In this case, the die is attached to heatslug so that the power that is dissipated can be conducted to the external surface of the package. This provides a highly efficient path for the transfer of heat to the package surface. The package configuration also provides an efficient thermal path from the ADV7150 to the Printed Circuit Board via the leads.

Heatsinks

The maximum silicon junction temperature should be limited to 100°C. Temperatures greater than this will reduce long term device reliability. To ensure that the silicon junction temperature stays within prescribed limits, the addition of an external heatsink may be necessary. Heatsinks, will reduce θ_{JA} as shown in the "Thermal Characteristics vs. Airflow" table.

APPENDIX 8

OUTLINE DIMENSIONS

Dimensions shown in inches and (mm).

S-160
160-Lead Plastic Power Quad Flatpack

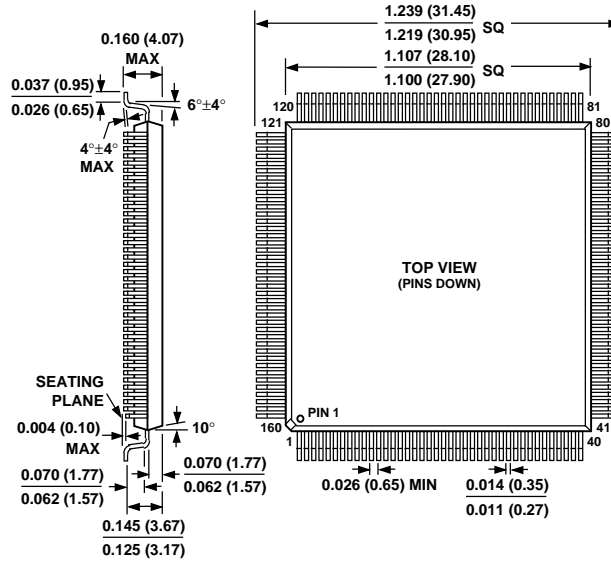



LittleDiode supplies new, hard to find or obsolete electronic components and semiconductors all over the world.

With over two million different components listed you are sure to find the part you need.

Feel free to visit us today at our online store:

LittleDiode.com

Looking forward to providing you with the best possible service.