



96-Bit, 220 MHz True-Color Video RAM-DAC

ADV7160/ADV7162

FEATURES

- 96-Bit Pixel Port for 1600 × 1280 × 24 Screen Resolution
- 220 MHz, 24-Bit (30-Bit Gamma Corrected) True-Color
- Triple 10-Bit "Gamma Correcting" D/A Converters
- 2% (max) DAC to DAC Color Matching
- Triple 256 × 10 (256 × 30) Color Palette RAM
- On-Board User Definable Cursor (64 × 64 × 2)
- Three Color Overlay
- Cursor Palette RAM
- Fully Programmable On-Board PLL
- RS-343A/RS-170 Compatible RGB Analog Outputs
- Tri-Level SYNC Functionality
- TTL Compatible Digital Inputs
- Standard MPU I/O Interface
- Programmable Pixel Port: 24-Bit, 16-Bit, 15-Bit & 8-Bit (Pseudo)
- Pixel Data Serializer:
 - Multiplexed Pixel Input Ports; 2:1, 4:1, 8:1
- +5 V CMOS Monolithic Construction
- 160-Lead Plastic Quad Flatpack (QFP): ADV7162
- 160-Lead "Thermally Enhanced" QFP (PQUAD): ADV7160

MODES OF OPERATION

- 1600 × 1200 × 30/24-Bit Resolution @ 85 Hz Screen Refresh
- 1600 × 1200 × 16/15-Bit Resolution @ 85 Hz Screen Refresh
- 1600 × 1200 × 8-Bit Resolution @ 85 Hz Screen Refresh

APPLICATIONS

- Windows Accelerators
- High Resolution, True Color Graphics
- Professional Color Prepress Imaging
- Digital TV (HDTV, Digital Video)

SPEED GRADES

- @ 220 MHz
- @ 170 MHz
- @ 140 MHz

GENERAL DESCRIPTION

The ADV7160/ADV7162® is a 96-bit pixel port Video RAM-DAC with color enhanced triple 10-bit DACs. The device also includes a PLL and 64 × 64 hardware cursor. The ADV7160/ADV7162 is specifically designed for use in the graphics subsystem of high performance, color graphics workstations and windows accelerators.

ADV is a registered trademark of Analog Devices, Inc.

(Continued on page 15)

FUNCTIONAL BLOCK DIAGRAM

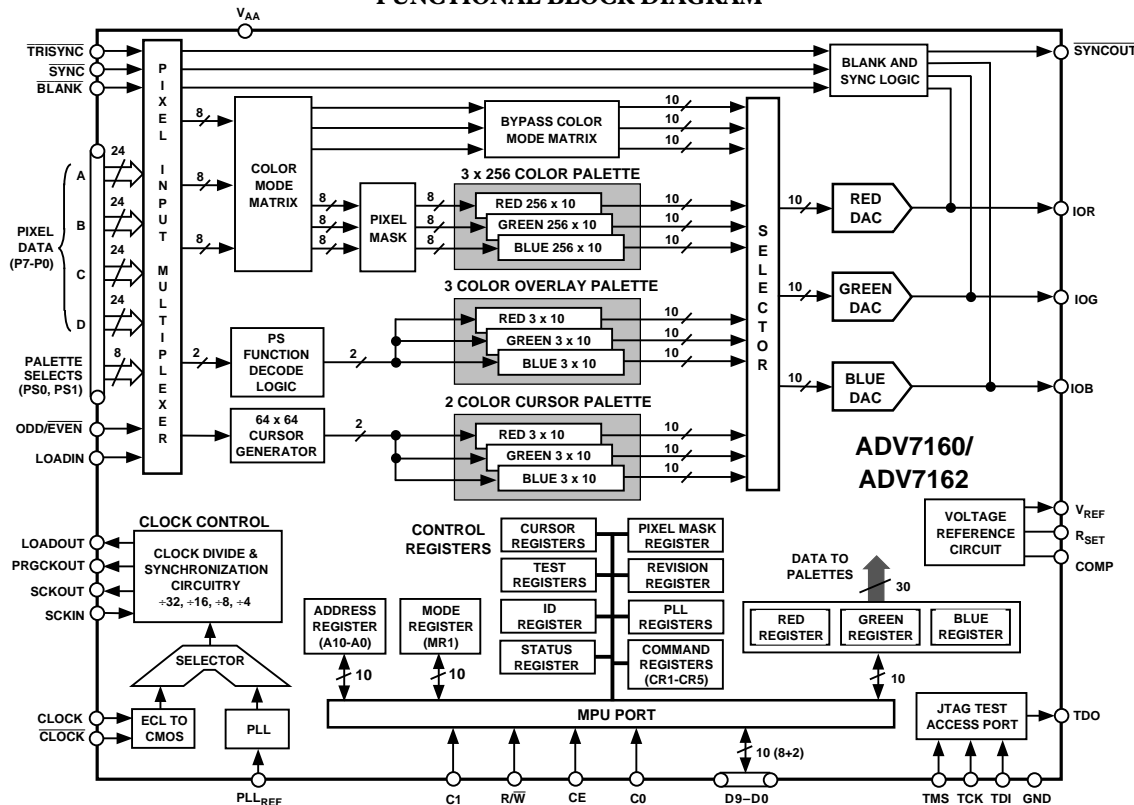

REV. 0

Information furnished by Analog Devices is believed to be accurate and reliable. However, no responsibility is assumed by Analog Devices for its use, nor for any infringements of patents or other rights of third parties which may result from its use. No license is granted by implication or otherwise under any patent or patent rights of Analog Devices.

© Analog Devices, Inc., 1995

One Technology Way, P.O. Box 9106, Norwood, MA 02062-9106, U.S.A.
Tel: 617/329-4700 Fax: 617/326-8703

ADV7160/ADV7162—SPECIFICATIONS ($V_{AA}^1 = +5\text{ V}$; $V_{REF} = +1.235\text{ V}$; $R_{SET} = 280\ \Omega$. IOR, IOG, IOB ($R_L = 37.5\ \Omega$, $C_L = 10\text{ pF}$). All specifications T_{MIN} to T_{MAX} ² unless otherwise noted.)

Parameter	Min	Typ	Max	Units	Test Conditions/Comments
STATIC PERFORMANCE					
Resolution (Each DAC)			10	Bits	(DAC Gain Setting = 3996)
Accuracy (Each DAC)					
Integral Nonlinearity			± 1	LSB	Guaranteed Monotonic
Differential Nonlinearity			± 1	LSB	
Gray Scale Error			± 5	% Gray Scale	
Coding				Binary	
DIGITAL INPUTS					
Input High Voltage, V_{INH}	2			V	$V_{IN} = 0.4\text{ V}$ or 2.4 V
Input Low Voltage, V_{INL}			0.8	V	
Input Current, I_{IN}			± 10	μA	
Input Capacitance, C_{IN}		10		pF	
CLOCK INPUTS (CLOCK, $\overline{\text{CLOCK}}$)					
Input High Voltage, V_{INH}	$V_{AA} - 1.0$			V	$V_{IN} = 0.4\text{ V}$ or 2.4 V
Input Low Voltage, V_{INL}			$V_{AA} - 1.6$	V	
Input Current, I_{IN}			± 10	μA	
Input Current, I_{IN} (JTAG Inputs)			± 50	μA	
Input Capacitance, C_{IN}		10		pF	$V_{IN} = 0.4\text{ V}$ or 2.4 V
DIGITAL OUTPUTS					
Output High Voltage, V_{OH}	2.4			V	$I_{SOURCE} = 400\ \mu\text{A}$ $I_{SINK} = 3.2\text{ mA}$
Output Low Voltage, V_{OL}			0.4	V	
Floating-State Leakage Current			20	μA	
Floating-State Output Capacitance		20		pF	
ANALOG OUTPUTS					
Gray Scale Current Range	15		22	mA	(DAC Gain Setting = 3996)
Output Current					
White Level Relative to Blank	17.69	19.05	20.40	mA	Sync Disabled Sync Enabled
White Level Relative to Black	16.74	17.62	18.50	mA	
Black Level Relative to Blank	0.95	1.44	1.90	mA	
Blank Level	0	5	50	μA	
Blank Level	6.29	7.62	8.96	mA	
Sync Level	0	5	50	μA	
Tri-Sync Level Relative to Blank	6.29	7.62	8.96	mA	
LSB Size		17.22		μA	
DAC to DAC Matching		1	3	%	
Output Compliance, V_{OC}	0		+1.4	V	
Output Impedance, R_{OUT}		30		k Ω	$I_{OUT} = 0\text{ mA}$
Output Capacitance, C_{OUT}			30	pF	
VOLTAGE REFERENCE					
Voltage Reference Range, V_{REF}	1.14	1.235	1.26	V	$V_{REF} = 1.235\text{ V}$ for Specified Performance
Input Current, I_{VREF}		5		μA	
POWER REQUIREMENTS					
V_{AA}		5		V	For 220 MHz Operation (ADV7160) For 170 MHz Operation (ADV7160) For 140 MHz Operation (ADV7160) For 220 MHz Operation (ADV7162) For 170 MHz Operation (ADV7162) For 140 MHz Operation (ADV7162) COMP = 0.1 μF
I_{AA}^3			475	mA	
			440	mA	
			410	mA	
I_{AA}^3			450	mA	
			400	mA	
			360	mA	
Power Supply Rejection Ratio		0.1		%/%	
DYNAMIC PERFORMANCE					
Clock and Data Feedthrough ^{4, 5}		-30		dB	
Glitch Impulse		50		pV secs	
DAC to DAC Crosstalk ⁶		-23		dB	

NOTES

¹ $\pm 5\%$ for all versions.

²Temperature range (T_{MIN} to T_{MAX}): 0°C to $+70^\circ\text{C}$.

³Pixel Port is continuously clocked with data corresponding to a linear ramp. $T_J = 100^\circ\text{C}$.

⁴Clock and data feedthrough is a function of the amount of overshoot and undershoot on the digital inputs. Glitch impulse includes clock and data feedthrough.

⁵TTL input values are 0 V to 3 V, with input rise/fall times $\leq 3\text{ ns}$, measured the 10% and 90% points. Timing reference points at 50% for inputs and outputs.

⁶DAC to DAC Crosstalk is measured by holding one DAC high while the other two are making low to high and high to low transitions.

Specifications subject to change without notice.

ADV7160/ADV7162

TIMING CHARACTERISTICS¹ ($V_{AA}^2 = +5\text{ V}$; $V_{REF} = +1.235\text{ V}$; $R_{SET} = 280\ \Omega$. IOR, IOG, IOB ($R_L = 37.5\ \Omega$, $C_L = 10\text{ pF}$). All specifications T_{MIN} to T_{MAX} ³ unless otherwise noted.)

CLOCK CONTROL AND PIXEL PORT⁴

Parameter	220 MHz Version	170 MHz Version	140 MHz Version	Units	Conditions/Comments
f_{CLOCK}	220	170	140	MHz max	Pixel CLOCK Rate
t_1	4.5	5.88	7.14	ns min	Pixel CLOCK Cycle Time
t_2	2.0	2.5	2.86	ns min	Pixel CLOCK High Time
t_3	2.0	2.5	2.86	ns min	Pixel CLOCK Low Time
t_4	10	10	10	ns max	Pixel CLOCK to LOADOUT Delay
f_{LOADIN}					LOADIN Clocking Rate
2:1 Multiplexing	110	85	70	MHz max	LOADIN Cycle Time
4:1 Multiplexing	55	42.5	35	MHz max	
8:1 Multiplexing	27.5	21.25	17.5	MHz max	
t_5					LOADIN High Time
2:1 Multiplexing	9.1	11.77	14.29	ns min	LOADIN Low Time
4:1 Multiplexing	18.18	23.53	28.58	ns min	
8:1 Multiplexing	36.36	47.1	57.16	ns min	
t_6					LOADIN High Time
2:1 Multiplexing	4	5	6	ns min	LOADIN Low Time
4:1 Multiplexing	8	9	12	ns min	
8:1 Multiplexing	15	18	23	ns min	
t_7					LOADIN Low Time
2:1 Multiplexing	4	5	6	ns min	LOADIN Low Time
4:1 Multiplexing	8	9	12	ns min	
8:1 Multiplexing	15	18	23	ns min	
t_8	0	0	0	ns min	Pixel Data Setup Time
t_9	5	5	5	ns min	Pixel Data Hold Time
t_{10}	0	0	0	ns min	LOADOUT to LOADIN Delay
$\tau-t_{11}$ ⁵	$\tau-5$	$\tau-5$	$\tau-5$	ns max	LOADOUT to LOADIN Delay
t_{PD} ⁶					Pipeline Delay ($1 \times \text{CLOCK} = t_1$)
2:1 Multiplexing	9	9	9	CLOCKs	Pipeline Delay ($1 \times \text{CLOCK} = t_1$)
4:1 Multiplexing	11	11	11	CLOCKs	
8:1 Multiplexing	15	15	15	CLOCKs	
t_{12}	10	10	10	ns max	Pixel CLOCK to PRGCKOUT Delay
t_{13}	5	5	5	ns max	SCKIN to SCKOUT Delay
t_{14}	5	5	5	ns min	BLANK to SCKIN Setup Time
t_{15}	0	0	0	ns min	BLANK to SCKIN Hold Time

ANALOG OUTPUTS⁷

Parameter	220 MHz Version	170 MHz Version	140 MHz Version	Units	Conditions/Comments
t_{16}	25	25	25	ns typ	Analog Output Delay
t_{17}	1	1	1	ns typ	Analog Output Rise/Fall Time
t_{18}	25	25	25	ns typ	Analog Output Transition Time
t_{SK}	2	2	2	ns max	RGB Analog Output Skew
	0	0	0	ns typ	

ADV7160/ADV7162

MPU PORT^{8,9}

Parameter	220 MHz Version	170 MHz Version	140 MHz Version	Units	Conditions/Comments
t ₁₉	0	0	0	ns min	R/ \overline{W} , C0, C1 to \overline{CE} Setup Time
t ₂₀	10	10	10	ns min	R/ \overline{W} , C0, C1 to \overline{CE} Hold Time
t ₂₁	45	45	45	ns min	\overline{CE} Low Time
t ₂₂	25	25	25	ns min	\overline{CE} High Time
t ₂₃ ⁸	5	5	5	ns min	\overline{CE} Asserted to Data-Bus Driven
t ₂₄ ⁹	45	45	45	ns max	\overline{CE} Asserted to Data Valid
t ₂₅ ⁹	20	20	20	ns max	\overline{CE} Disabled to Data-Bus Three-Stated
t ₂₆ ⁹	5	5	5	ns min	\overline{CE} Disabled to Data Invalid
t ₂₇	20	20	20	ns min	Write Data (D0–D9) Setup Time
t ₂₈	5	5	5	ns min	Write Data (D0–D9) Hold Time

NOTES

General Notes

¹TTL input values are 0 to 3 volts, with input rise/fall times ≤ 3 ns, measured between the 10% and 90% points.

ECL inputs (CLOCK, \overline{CLOCK}) are $V_{AA}-0.8$ V to $V_{AA}-1.8$ V, with input rise/fall times ≤ 2 ns, measured between the 10% and 90% points.

Timing reference points at 50% for inputs and outputs.

Analog output load ≤ 10 pF.

Data-Bus (D0–D9) loaded as shown in Figure 1.

Digital output load for LOADOUT, PRGCKOUT & SCKOUT ≤ 30 pF.

² $\pm 5\%$ for all versions

³Temperature range (T_{MIN} to T_{MAX}): 0°C to +70°C.

Notes on PIXEL PORT

⁴Pixel Port consists of the following inputs:

Pixel Inputs: RED [A, B, C, D] GREEN [A, B, C, D] BLUE [A, B, C, D]

Palette Selects: PS0 [A, B, C, D]; PS1[A, B, C, D]

Pixel Controls: SYNC, BLANK, TRISYNC, ODD/EVEN

Clock Inputs: CLOCK, \overline{CLOCK} , LOADIN, SCKIN

Clock Outputs: LOADOUT, PRGCKOUT, SCKOUT

⁵ τ is the LOADOUT Cycle Time and is a function of the Pixel CLOCK Rate and the Multiplexing Mode:

2:1 multiplexing; $\tau = \text{CLOCK} \times 2 = 2 \times t_1$ ns

4:1 multiplexing; $\tau = \text{CLOCK} \times 4 = 4 \times t_1$ ns

8:1 multiplexing; $\tau = \text{CLOCK} \times 8 = 8 \times t_1$ ns

⁶These fixed values for Pipeline Delay are valid under conditions where t_{10} and $\tau-t_{11}$ are met. If either t_{10} or $\tau-t_{11}$ are not met, the part will operate but the Pipeline Delay is increased.

Notes on ANALOG OUTPUTS

⁷Output delay measured from the 50% point of the rising edge of CLOCK to the 50% point of full-scale transition.

Output rise/fall time measured between the 10% and 90% points of full-scale transition.

Transition time measured from the 50% point of full scale transition to the output remaining within 2% of the final output value. (Transition time does not include clock and data feedthrough).

Notes on MPU PORT

⁸t₂₃ and t₂₄ are measured with the load circuit of Figure 1 and defined as the time required for an output to cross 0.4 V or 2.4 V.

⁹t₂₅ and t₂₆ are derived from the measured time taken by the data outputs to change by 0.5 V when loaded with the circuit of Figure 1. The measured numbers are then extrapolated back to remove the effects of charging the 100 pF capacitor. This means that the times t₂₅ and t₂₆, quoted in the Timing Characteristics are the true values for the device and as such are independent of external loading capacitances.

Specifications subject to change without notice.

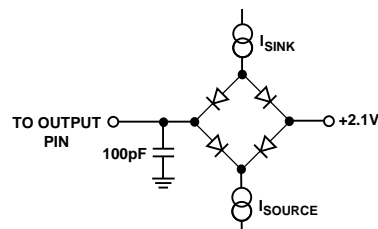

Figure 1. Load Circuit for Databus Access and Relinquish Times

TIMING CHARACTERISTICS (Cont.)¹ ($V_{AA}^2 = +5\text{ V}$; $V_{REF} = +1.235\text{ V}$; $R_{SET} = 280\ \Omega$. IOR, IOG, IOB ($R_L = 37.5\ \Omega$, $C_L = 10\text{ pF}$). All specifications T_{MIN} to T_{MAX} ³ unless otherwise noted.)

JTAG PORT

Parameter	All Versions	Units	Conditions/Comments
PLL PERFORMANCE ⁴			
Jitter	250	ps rms	1 σ
PLL REFERENCE INPUT			
PLL _{REF} Frequency	900	kHz min	
	40	MHz max	
V _{IH}	2.0	V max	
V _{IL}	0.8	V min	
PLL _{REF} Period	25	ns min	
	1.67	μ s max	
PLL _{REF} Duty Cycle	40	% min	
	60	% max	
JTAG PERFORMANCE			
TCK Frequency, t ₂₉	20	MHz max	
TCK High Time, t ₃₀	15	ns min	
TCK Low Time, t ₃₁	15	ns min	
TDI, TMS Setup Time, t ₃₂	15	ns max	
TDI, TMS Hold Time, t ₃₃	15	ns max	
Digital Input to $\overline{\text{TCK}}$ Setup Time, t ₃₄	15	ns max	
Digital Input to $\overline{\text{TCK}}$ Hold Time, t ₃₅	15	ns max	
TCLK to TDO Drive, t ₃₆	0	ns min	
TCLK to TDO Valid, t ₃₇	20	ns min	
TCLK to TDO Three-State, t ₃₈	5	ns min	
	15	ns max	

NOTES

¹TTL input values are 0 to 3 volts, with input rise/fall times $\leq 3\text{ ns}$, measured between the 10% and 90% points. Timing reference points at 50% for inputs and outputs.

² $\pm 5\%$ for all versions.

³Temperature range (T_{MIN} to T_{MAX}); 0°C to +70°C.

⁴Jitter is measured by triggering on the output clock, delayed by 15 μ s and then measuring the time period from the trigger edge to the next edge of the output clock after the delay. This measurement is repeated multiple times and the RMS value is determined.

Specifications subject to change without notice.

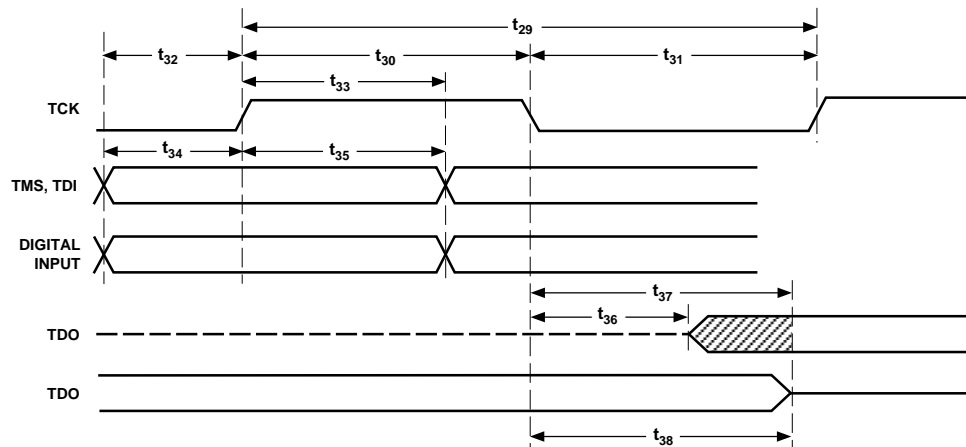

Figure 2. JTAG Timing

ADV7160/ADV7162

Timing Waveforms

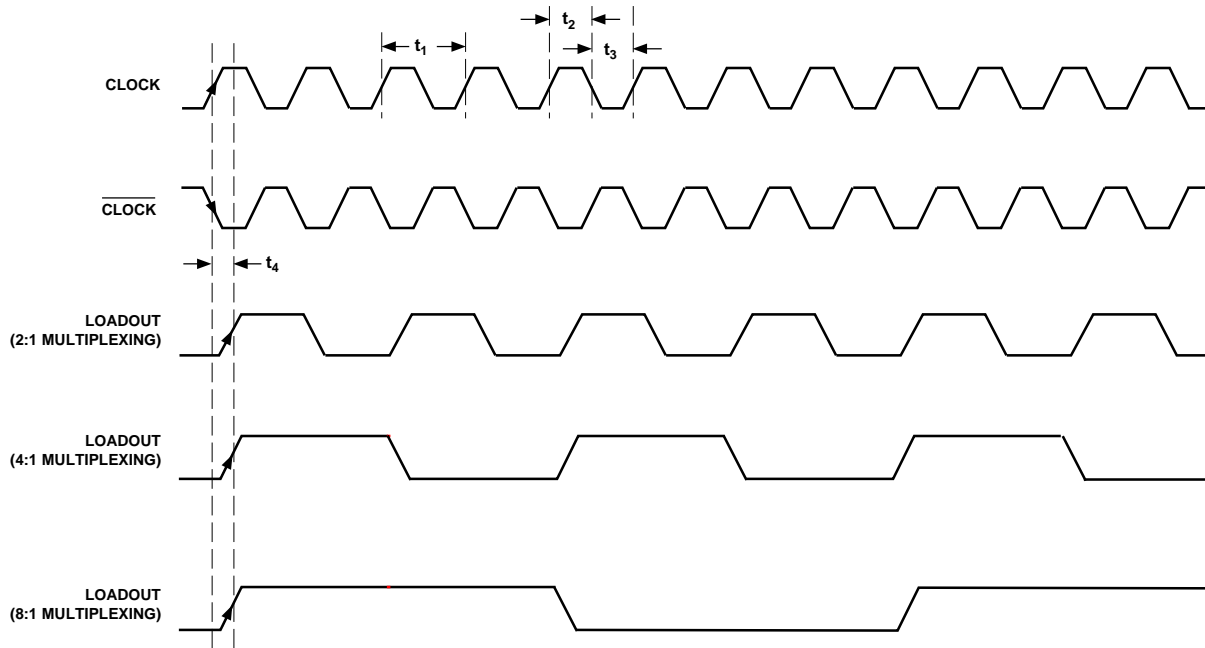

Figure 3. LOADOUT vs. Pixel Clock Input (CLOCK, $\overline{\text{CLOCK}}$)

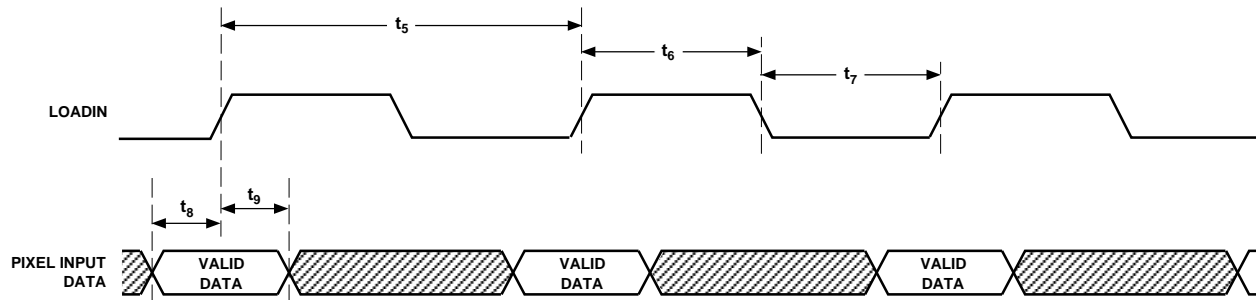

Figure 4. LOADIN vs. Pixel Input Data

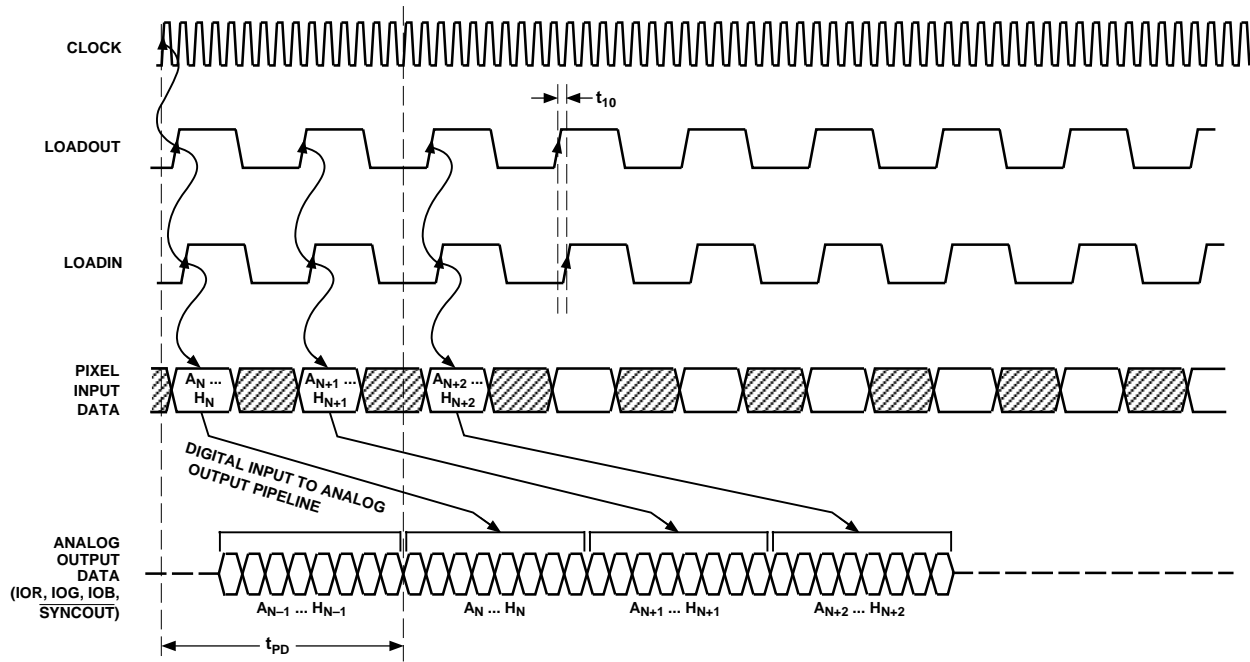

Figure 5. Pixel Input to Analog Output Pipeline with Minimum LOADOUT to LOADIN Delay (8:1 Multiplex Mode)

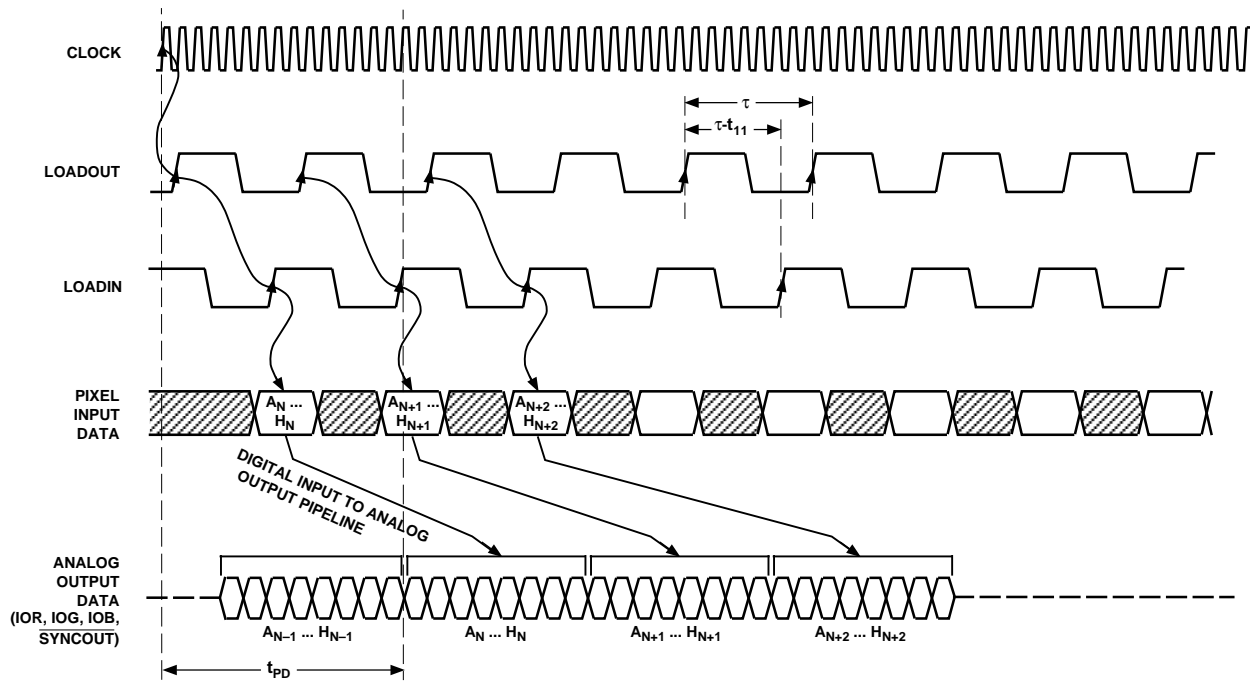

Figure 6. Pixel Input to Analog Output Pipeline with Maximum LOADOUT to LOADIN Delay (8:1 Multiplex Mode)

ADV7160/ADV7162

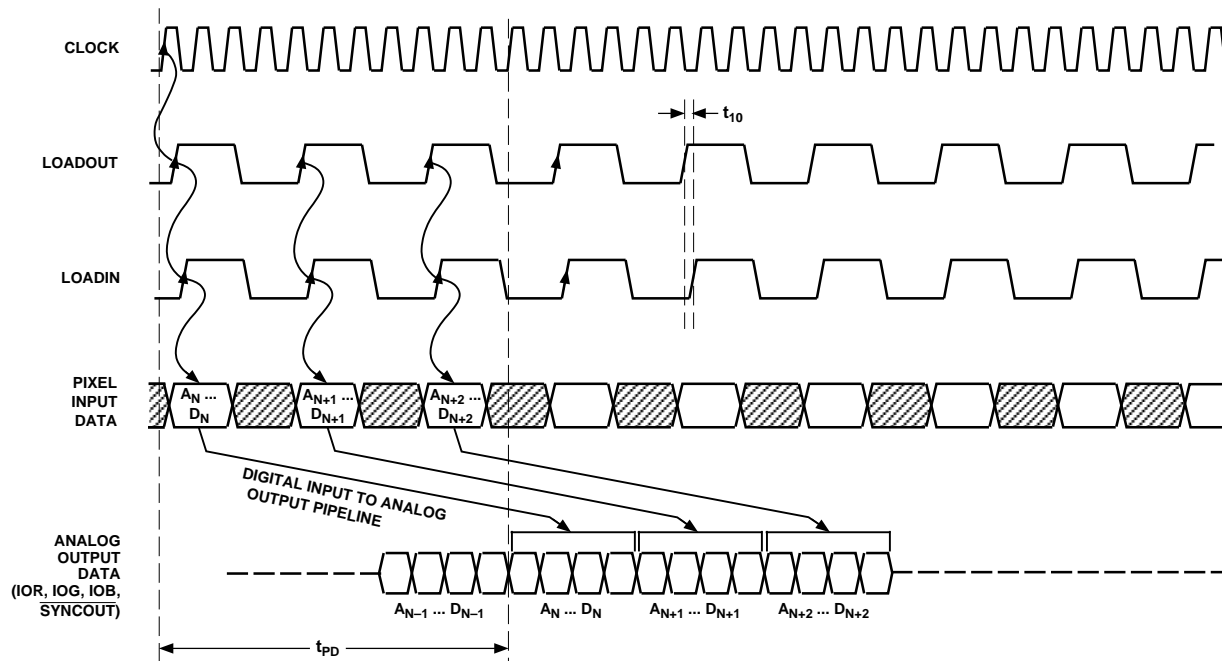

Figure 7. Pixel Input to Analog Output Pipeline with Minimum LOADOUT to LOADIN Delay (4:1 Multiplex Mode)

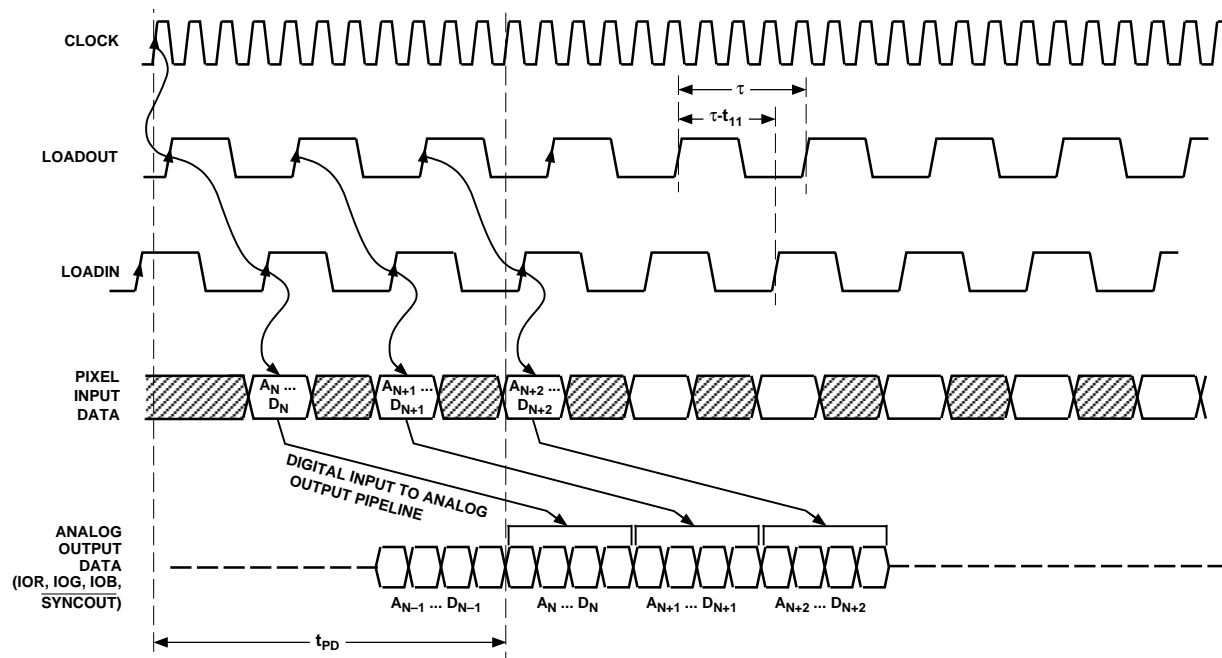

Figure 8. Pixel Input to Analog Output Pipeline with Maximum LOADOUT to LOADIN Delay (4:1 Multiplex Mode)

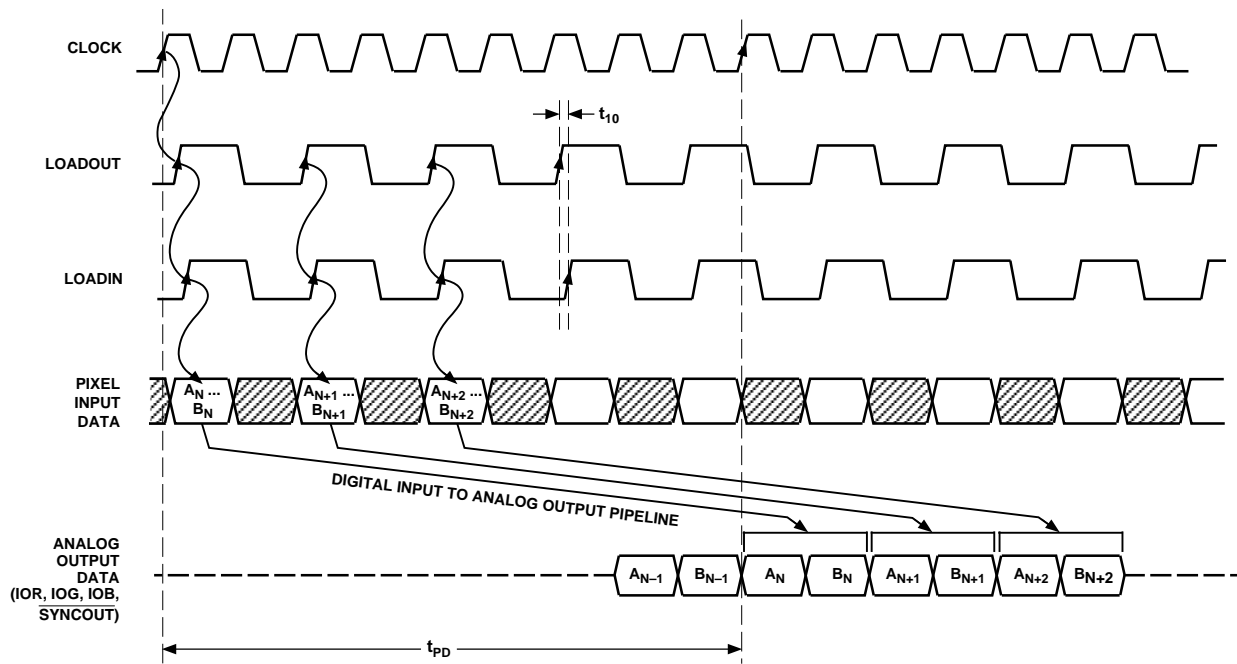

Figure 9. Pixel Input to Analog Output Pipeline with Minimum LOADOUT to LOADIN Delay (2:1 Multiplex Mode)

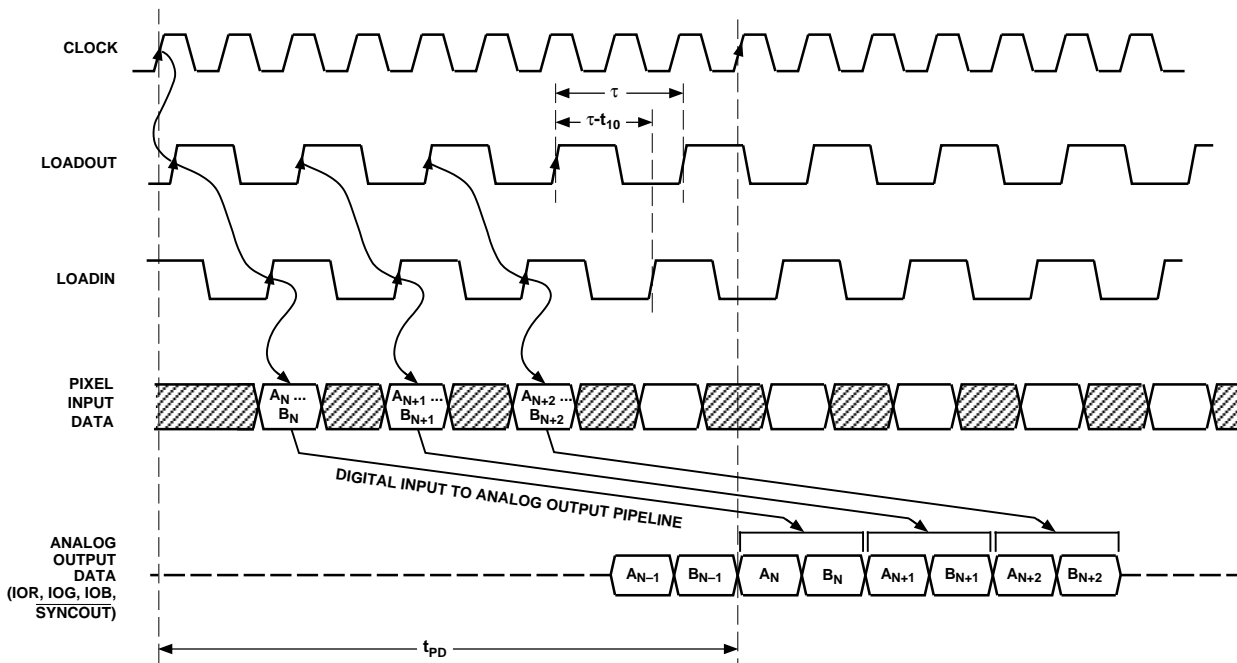

Figure 10. Pixel Input to Analog Output Pipeline with Maximum LOADOUT to LOADIN Delay (2:1 Multiplex Mode)

ADV7160/ADV7162

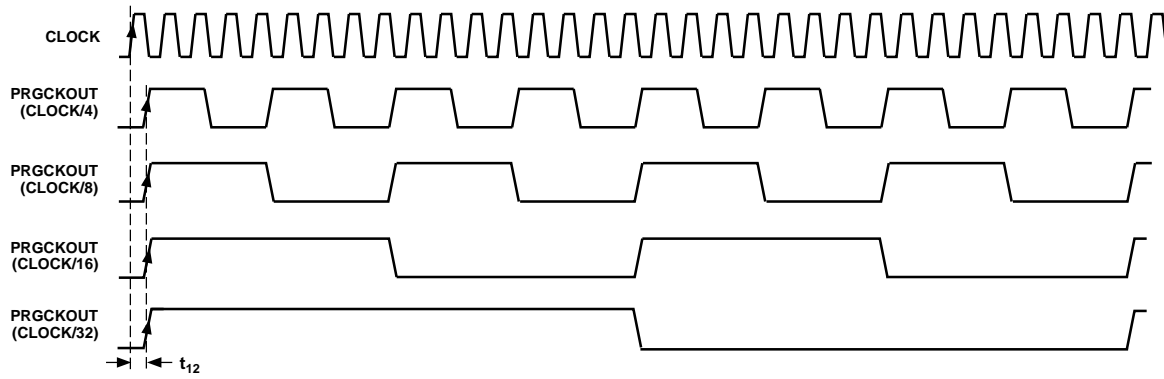

Figure 11. Pixel Clock Input vs. Programmable Clock Output (PRGCKOUT)

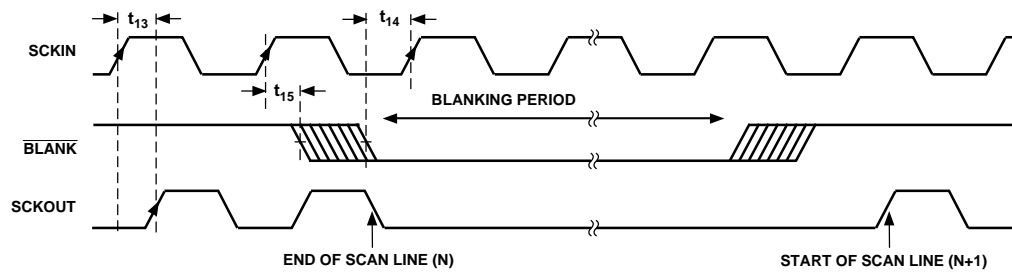

Figure 12. Video Data Shift Clock Input (SCKIN) & BLANK vs. Video Data Shift Clock Output (SCKOUT)

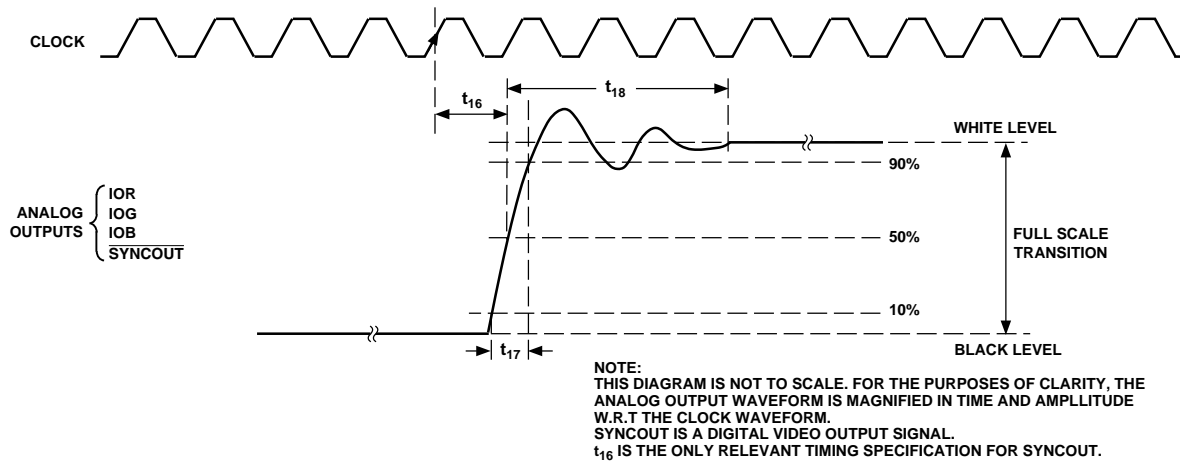

Figure 13. Analog Output Response vs. CLOCK

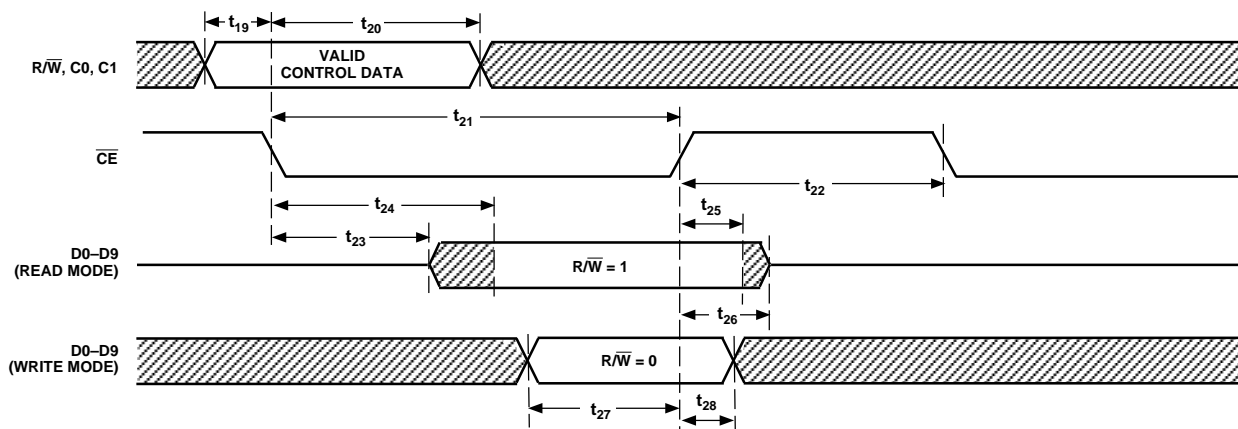

Figure 14. Microprocessor Port (MPU) Interface Timing

ABSOLUTE MAXIMUM RATINGS¹

- V_{AA} to GND 7 V
- Voltage on Any Digital Pin GND – 0.5 V to V_{AA} + 0.5 V
- Ambient Operating Temperature (T_A) 0°C to +70°C
- Storage Temperature (T_S) –65°C to +150°C
- Junction Temperature (T_J) +150°C
- Lead Temperature (Soldering, 10 secs) +260°C
- Vapor Phase Soldering (1 minute) +220°C
- Analog Outputs to GND² GND – 0.5 V to V_{AA}

NOTES

- ¹Stresses above those listed under “Absolute Maximum Ratings” may cause permanent damage to the device. This is a stress rating only and functional operation of the device at these or any other conditions above those listed in the operational sections of this specification is not implied. Exposure to absolute maximum rating conditions for extended periods may affect device reliability.
- ²Analog Output Short Circuit to any Power Supply or Common can be of an indefinite duration.

ORDERING INFORMATION^{1, 2, 3}

Dot Clock Speed		
220 MHz	170 MHz	140 MHz
ADV7160KS220 ³	ADV7160KS170 ³	ADV7160KS140 ³
ADV7162KS220 ⁴	ADV7162KS170 ⁴	ADV7162KS140 ⁴

NOTES

- ¹All devices are specified for 0°C to +70°C operation.
- ²Contact Sales Office for latest information on package design.
- ³ADV7160 is packaged in a 160-pin plastic power quad flatpack, QFP with heatsink embedded.
- ⁴ADV7162 is packaged in a standard 160-pin plastic quad flatpack, QFP.

CAUTION

ESD (electrostatic discharge) sensitive device. Electrostatic charges as high as 4000 V readily accumulate on the human body and test equipment and can discharge without detection. Although the ADV7160/ADV7162 features proprietary ESD protection circuitry, permanent damage may occur on devices subjected to high energy electrostatic discharges. Therefore, proper ESD precautions are recommended to avoid performance degradation or loss of functionality.

160-Lead QFP Configuration

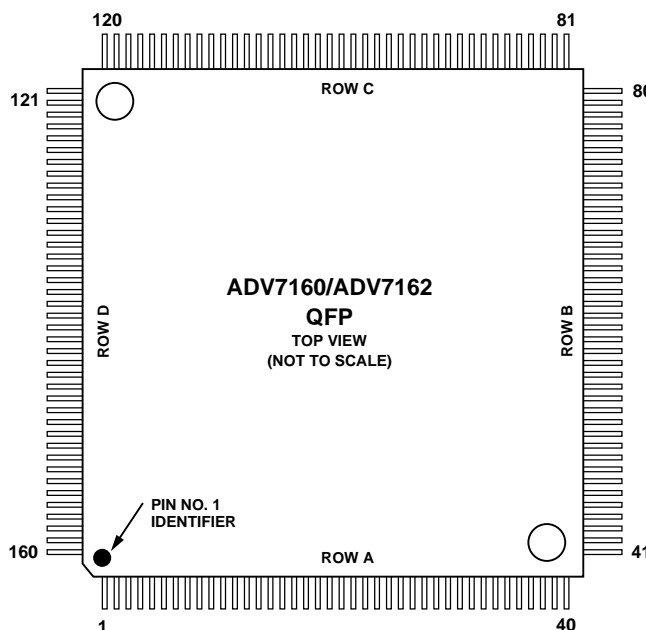

ADV7160/ADV7162

ADV7160/ADV7162 PIN ASSIGNMENTS

Pin No.	Mnemonic	Pin No.	Mnemonic	Pin No.	Mnemonic	Pin No.	Mnemonic
1	G2 _A	41	$\overline{\text{CLOCK}}$	81	D9	121	R1 _C
2	G2 _B	42	SCKIN	82	D8	122	R1 _D
3	G2 _C	43	SCKOUT	83	D7	123	R2 _A
4	G2 _D	44	V _{AA}	84	D6	124	R2 _B
5	G3 _A	45	PRGCKOUT	85	D5	125	R2 _C
6	G3 _B	46	GND	86	D4	126	R2 _D
7	G3 _C	47	LOADOUT	87	D3	127	R3 _A
8	G3 _D	48	LOADIN	88	D2	128	R3 _B
9	G4 _A	49	B0 _A	89	D1	129	R3 _C
10	G4 _B	50	B0 _B	90	D0	130	R3 _D
11	G4 _C	51	B0 _C	91	C1	131	R4 _A
12	G4 _D	52	B0 _D	92	C0	132	V _{AA}
13	G5 _A	53	B1 _A	93	$\overline{\text{R/W}}$	133	V _{AA}
14	G5 _B	54	B1 _B	94	$\overline{\text{CE}}$	134	GND
15	G5 _C	55	B1 _C	95	TCK	135	GND
16	G5 _D	56	B1 _D	96	TMS	136	R4 _B
17	G6 _A	57	B2 _A	97	GND	137	R4 _C
18	G6 _B	58	B2 _B	98	V _{AA}	138	R4 _D
19	G6 _C	59	B2 _C	99	TDO	139	R5 _A
20	G6 _D	60	B2 _D	100	TDI	140	R5 _B
21	G7 _A	61	B3 _A	101	$\overline{\text{SYNCOUT}}$	141	R5 _C
22	V _{AA}	62	B3 _B	102	$\overline{\text{TRISYNC}}$	142	R5 _D
23	V _{AA}	63	B3 _C	103	$\overline{\text{ODD/EVEN}}$	143	R6 _A
24	GND	64	B3 _D	104	$\overline{\text{SYNC}}$	144	R6 _B
25	GND	65	B4 _A	105	$\overline{\text{BLANK}}$	145	R6 _C
26	V _{AA}	66	B4 _B	106	V _{REF}	146	R6 _D
27	GND	67	B4 _C	107	IOB	147	R7 _A
28	PLL _{REF}	68	B4 _D	108	COMP	148	R7 _B
29	G7 _B	69	B5 _A	109	R _{SET}	149	R7 _C
30	G7 _C	70	B5 _B	110	V _{AA}	150	GND
31	G7 _D	71	B5 _C	111	V _{AA}	151	V _{AA}
32	PS0 _A	72	B5 _D	112	GND	152	R7 _D
33	PS0 _B	73	B6 _A	113	IOG	153	G0 _A
34	PS0 _C	74	B6 _B	114	IOR	154	G0 _B
35	PS0 _D	75	B6 _C	115	R0 _A	155	G0 _C
36	PS1 _A	76	B6 _D	116	R0 _B	156	G0 _D
37	PS1 _B	77	B7 _A	117	R0 _C	157	G1 _A
38	PS1 _C	78	B7 _B	118	R0 _D	158	G1 _B
39	PS1 _D	79	B7 _C	119	R1 _A	159	G1 _C
40	CLOCK	80	B7 _D	120	R1 _B	160	G1 _D

PIN FUNCTION DESCRIPTION

Mnemonic	Function
RED (R0 _A . . . R0 _B – R7 _A . . . R7 _D), GREEN (G0 _A . . . G0 _D – G7 _A . . . G7 _D), BLUE (B0 _A . . . B0 _D – B7 _A . . . B7 _D):	Pixel Port (TTL Compatible Inputs): 96 pixel select inputs, with 8 bits each for Red, Green and Blue. Each bit is multiplexed [A-D] 4:1 or 2:1. It can be configured for 24-Bit True-Color Data, 8-Bit Pseudo-Color Data, 16-Bit True-Color and 15-Bit True-Color Data formats. In 8-Bit Pseudo-Color Mode, there is a special case whereby 8:1 multiplexing is also available. It will be explained in more detail later. Pixel Data is latched into the device on the rising edge of LOADIN.
PS0 _A . . . PS0 _D , PS1 _A . . . PS1 _D	Palette Priority Selects (TTL Compatible Inputs): The eight PS inputs provide two Bits after input multiplexing. These pixel port select inputs can be configured for three separate functions. In Overlay Mode, these inputs provide a three color overlay function. With any value other than “00” on the overlay inputs, the color displayed comes from the overlay palette instead of the main pixel inputs. For the ADV7160, in Bypass Mode, PS1 specifies for each pixel whether it should pass through the Color Matrix and Color Palette or bypass the Matrix and Palette. PS0 acts as an overlay input. (This mode is not available for the ADV7162.) Palette Select Mode is used to multiplex the RGB outputs of a number of devices. When the palette mode inputs match the PS bits in the mode register, the part operates as normal. When there is a mismatch, the RGB outputs are switched to zero, allowing the RGB outputs of another device to drive the monitor.
LOADIN	Pixel Data Load Input (TTL Compatible Input): This input latches the multiplexed pixel data, including PS0-PS1, $\overline{\text{BLANK}}$, $\overline{\text{TRISYNC}}$, $\overline{\text{SYNC}}$ and ODD/EVEN into the device.
LOADOUT	Pixel Data Load Output (TTL Compatible Output): This output control signal runs at a divided down frequency of the pixel clock. Its frequency is a function of the multiplex rate. It can be used to directly or indirectly drive LOADIN. $f_{\text{LOADOUT}} = f_{\text{CLOCK}}/M$ where (M = 2 for 2:1 Multiplex Mode) (M = 4 for 4:1 Multiplex Mode) (M = 8 for 8:1 Multiplex Mode)
PRGCKOUT	Programmable Clock Output (TTL Compatible Output): This output control signal runs at a divided down frequency of the pixel Clock. Its frequency is user programmable and is determined by bits CR30 and CR31 of Command Register 3. $f_{\text{PRGCKOUT}} = f_{\text{CLOCK}}/N$ where N = 4, 8, 16 & 32
SCKIN	Video Shift Clock Input (TTL Compatible Input): The signal on this input is internally gated synchronously with the $\overline{\text{BLANK}}$ signal. The resultant output, SCKOUT, is a video clocking signal that is stopped during video blanking periods. It is normally driven by a divided down version of the CLOCK frequency.
SCKOUT	Video Shift Clock Output (TTL Compatible Output): This output is a synchronously gated version of SCKIN and $\overline{\text{BLANK}}$. SCKOUT is a video clocking signal that is stopped during video blanking periods.
CLOCK, $\overline{\text{CLOCK}}$	Clock Inputs (ECL Compatible Inputs): These differential clock inputs are designed to be driven by ECL logic levels configured for single supply (+5 V) operation. The clock rate is normally the pixel clock rate of the system.
PLL _{REF}	PLL Clock Input (TTL Compatible Input): This clock input is designed to be driven by TTL logic levels. The PLL is then configured to output a specific frequency depending on the PLL Registers. See PLL section for more detail.
$\overline{\text{BLANK}}$	Composite Blank (TTL Compatible Input): This video control signal drives the analog outputs to the blanking level.
$\overline{\text{SYNC}}$	Composite-Sync Input (TTL Compatible Input): This video control signal drives any of the analog outputs to the $\overline{\text{SYNC}}$ level. It is only asserted during the blanking period. CR22 in Command Register 2 must be set if $\overline{\text{SYNC}}$ is to be decoded onto the IOG analog output, CR41 in Command Register 4 must be set if $\overline{\text{SYNC}}$ is to be decoded onto the IOR analog output, CR42 in Command Register 4 must be set if $\overline{\text{SYNC}}$ is to be decoded onto the IOB analog output, otherwise the $\overline{\text{SYNC}}$ input is ignored.

ADV7160/ADV7162

Mnemonic	Function																									
$\overline{\text{SYNCOUT}}$	Composite-Sync Output (TTL Compatible Output). This video output is a delayed version of $\overline{\text{SYNC}}$. The delay corresponds to the number of pipeline stages of the device.																									
$\overline{\text{TRISYNC}}$	Composite-Sync HDTV Control (TTL Compatible Output). This video input is enabled using Bit CR17 in Command Register 1. When $\overline{\text{TRISYNC}}$ is low, any DAC output which has Sync enabled, goes to the tri-sync level. As with the $\overline{\text{SYNC}}$ input, it should only be activated while $\overline{\text{BLANK}}$ is low.																									
D9–D0	Data Bus (TTL Compatible Input/Output Bus). Data, including color palette values and device control information is written to and read from the device over this 10-bit, bidirectional databus. 10-bit data or 8-bit data can be used. The databus can be configured for either 10-bit parallel data or byte data (8+2) as well as standard 8-bit data. Any unused bits of the data bus should be terminated through a resistor to either the digital power plane (V_{CC}) or GND.																									
ODD/ $\overline{\text{EVEN}}$	Odd/Even Control (TTL Compatible Input). This input indicates which field of the frame is being displayed. It is required to ensure proper operation of the ADV7160/ADV7162 cursor when interlaced display mode is selected. It is ignored when noninterlaced display mode is selected. This input should change only during the vertical blank period. It is assumed that an odd field will always follow an even field and vice versa.																									
$\overline{\text{CE}}$	Chip Enable (TTL Compatible Input). This input must be at Logic “0” when writing to or reading from the device over the data bus (D0–D9). Internally, data is latched on the rising edge of $\overline{\text{CE}}$.																									
$\overline{\text{R/W}}$	Read/Write Control (TTL Compatible Input). This input determines whether data is written to or read from the device’s registers and color palette RAM. $\overline{\text{R/W}}$ and $\overline{\text{CE}}$ must be at Logic “0” to write data to the part. $\overline{\text{R/W}}$ must be at Logic “1” and $\overline{\text{CE}}$ at Logic “0” to read from the device.																									
C0, C1	Command Controls (TTL Compatible Inputs). These inputs determine the type of read or write operation being performed on the device over the data bus, (see Interface Truth Table). Data on these inputs is latched on the falling edge of $\overline{\text{CE}}$.																									
IOR, IOG, IOB	Red, Green & Blue Current Outputs (High Impedance Current Sources). These RGB video outputs are specified to directly drive RS-343A and RS-170 video levels into doubly terminated 75 Ω loads.																									
V_{REF}	Voltage Reference Input (Analog Input): An external 1.235 V voltage reference is required to drive this input. An AD589 (2-terminal voltage reference) or equivalent is recommended. (Note: It is not recommended to use a resistor network to generate the voltage reference.)																									
R_{SET}	Output Full Scale Adjust Control (Analog Input). A resistor connected between this pin and analog ground controls the absolute amplitude of the output video signal. For a value of R_{SET} of nominally 280 Ω , with 37.5 Ω termination and using CR43 and CR44 of Command Register 4 to set the DAC Gain as shown, the required Video Standard can be achieved.																									
	<table border="1"> <thead> <tr> <th>CR44</th> <th>CR43</th> <th>Video Standard</th> <th>DAC Gain</th> <th>Black to White</th> </tr> </thead> <tbody> <tr> <td>0</td> <td>0</td> <td>RS343A, Sync & Pedestal</td> <td>3996</td> <td>660 mV 17.62 mA</td> </tr> <tr> <td>0</td> <td>1</td> <td>RS343A, Sync & No Pedestal</td> <td>4224</td> <td>699 mV 18.63 mA</td> </tr> <tr> <td>1</td> <td>0</td> <td>RS343A, No Sync & No Pedestal</td> <td>4311</td> <td>714 mV 19.05 mA</td> </tr> <tr> <td>1</td> <td>1</td> <td>RS170, Sync & Pedestal</td> <td>5592</td> <td>925 mV 24.67 mA</td> </tr> </tbody> </table>	CR44	CR43	Video Standard	DAC Gain	Black to White	0	0	RS343A, Sync & Pedestal	3996	660 mV 17.62 mA	0	1	RS343A, Sync & No Pedestal	4224	699 mV 18.63 mA	1	0	RS343A, No Sync & No Pedestal	4311	714 mV 19.05 mA	1	1	RS170, Sync & Pedestal	5592	925 mV 24.67 mA
CR44	CR43	Video Standard	DAC Gain	Black to White																						
0	0	RS343A, Sync & Pedestal	3996	660 mV 17.62 mA																						
0	1	RS343A, Sync & No Pedestal	4224	699 mV 18.63 mA																						
1	0	RS343A, No Sync & No Pedestal	4311	714 mV 19.05 mA																						
1	1	RS170, Sync & Pedestal	5592	925 mV 24.67 mA																						
	Alternatively, R_{SET} can be calculated by the following equation:																									
	$R_{SET} = \frac{DAC\ Gain \times V_{REF}}{Black\ to\ White\ Current}$																									
COMP	Compensation Pin. A 0.1 μF capacitor should be connected between this pin and V_{AA} .																									
V_{AA}	Power Supply (+5 V \pm 5%). The part contains multiple power supply pins, all should be connected together to one common +5 V filtered analog power supply.																									
GND:	Analog Ground. The part contains multiple ground pins, all should be connected together to the system’s ground plane.																									
TMS, TCK, TDI, TDO	These four pins control the JTAG test access port. See Appendix 6 for more detail																									

(Continued from page 1)

The ADV7160/ADV7162 integrates a number of graphic functions onto one device allowing 24-bit direct True-Color (30-bit Corrected-Color) operation at the maximum screen resolution of 1600×1280 at a refresh rate of 85 Hz. The ADV7160/ADV7162 integrates a 256×30 Color Palette RAM with three high speed, 10-bit, digital-to analog converters (RGB DACs). It also contains a user-definable, X-Windows compatible, $64 \times 64 \times 2$ cursor generator and associated RAM. An on-board Overlay Palette RAM is also included. The device's 96-bit Programmable Pixel Port enables various data formats to be input to the part. An on-board clock and synchronization circuit controls all clocking functions for both the part and graphics subsystem.

There are two video data paths through the ADV7160/ADV7162. One routes the data from the pixel port through the RAM to the DACs, the other bypasses the RAM and routes data direct from the pixel port to the DACs. Either path can be selected on a pixel by pixel basis. This allows for the overlay of an active video window on a graphics background.

The on-board palette priority select inputs enable multiple palette devices to be connected together for use in multipalette and window applications. The part is controlled and programmed through the microprocessor (MPU) port.

The 30 bits of resolution, associated with the color look-up table and triple 10-bit DAC, realizes 24-bit True-Color resolution, while also allowing for the on-board implementation of linearization algorithms, such as Gamma-Correction and Monitor Calibration. This allows effective 30-bit True-Color operation.

The on-chip video clock controller circuit generates all the internal clocking and some additional external clocking signals. The high accuracy, low jitter on board PLL eliminates the need for an external high speed clock generator. The PLL can be programmed to produce a pixel clock that is a multiple of the PLL reference clock.

The ADV7162 is packaged in a standard plastic 160-pin quad flatpack (QFP).

The ADV7160 is packaged in a plastic 160-pin power quad flatpack (PQUAD). Superior thermal distribution is achieved by the inclusion of a copper heatslug, within the standard package outline, to which the die is attached. This part is ideally suited for high performance applications where external environmental conditions are unpredictable and uncontrollable.

CIRCUIT DETAILS AND OPERATION

OVERVIEW

Digital video or pixel data is latched into the ADV7160/ADV7162 over the devices Pixel Port. This data acts as a pointer to on-board Color Palette RAM. The data at the RAM address pointed to is latched to the digital-to-analog converters (DACs) and output as an RGB analog video signal.

For the purposes of clarity of description, the ADV7160/ADV7162 is broken down into three separate functional blocks. These are:

1. Pixel Port and Clock Control Circuit
2. MPU Port, Registers and Color Palette
3. Digital-to-Analog Converters and Video Outputs

Pixel Port & Clock Control Circuit

The Pixel Port of the ADV7160/ADV7162 is directly interfaced to the video/graphics pipeline of a computer graphics subsystem. It is connected directly or through a gate array to the video RAM of the systems Frame-Buffer (video memory). The pixel port on the device consists of:

Color Data	RED, GREEN, BLUE
Pixel Controls	SYNC, BLANK, TRISYNC
Palette Selects	PS _{A-D} , PS _{1A-D}

The associated clocking signals for the pixel port include:

Clock Inputs	CLOCK, $\overline{\text{CLOCK}}$, PLL _{REF} , LOADIN, SCKIN
Clock Outputs	LOADOUT, PRGCKOUT, SCKOUT

These on-board clock control signals are included to simplify interfacing between the part and the frame buffer. Either two control input signals CLOCK and $\overline{\text{CLOCK}}$ (ECL Levels) or

one TTL input signal PLL_{REF} are required to get the part operational. No additional signals or external glue logic are required to get the Pixel Port and Clock Control Circuit of the part operational.

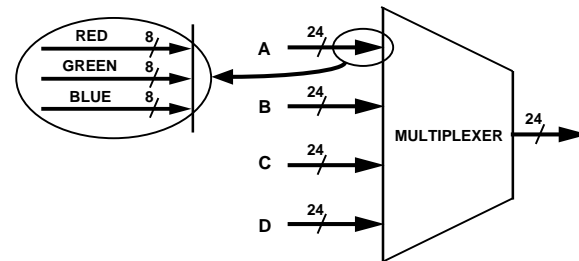

Figure 15. Multiplexed Color Inputs for the ADV7160/ADV7162

Pixel Port (Color Data)

The ADV7160/ADV7162 has 96 color data inputs. The part has four (for 4:1 multiplexing) 24-bit wide direct color data inputs. These are user programmed to support a number of color data formats including 24-bit True-Color, 16-bit True-Color, 15-bit True-Color in 4:1 and 2:1 multiplex modes, and 8-bit Pseudo-Color (see "Multiplexing" section) in 8:1, 4:1 and 2:1 multiplex modes.

Color data is latched into the parts pixel port on every rising edge of LOADIN (see Timing Waveform, Figure 4). The required frequency of LOADIN is determined by the multiplex rate, where

$$\begin{aligned}
 f_{\text{LOADIN}} &= f_{\text{CLOCK}}/8 && 8:1 \text{ multiplex mode} \\
 f_{\text{LOADIN}} &= f_{\text{CLOCK}}/4 && 4:1 \text{ multiplex mode} \\
 f_{\text{LOADIN}} &= f_{\text{CLOCK}}/2 && 2:1 \text{ multiplex mode}
 \end{aligned}$$

ADV7160/ADV7162

Other pixel data signals latched into the device by $\overline{\text{LOADIN}}$ include $\overline{\text{SYNC}}$, $\overline{\text{BLANK}}$, $\overline{\text{TRISYNC}}$ and $\text{PS0}_{\text{A-D}} - \text{PS1}_{\text{A-D}}$.

Internally, data is pipelined through the part by the differential pixel clock inputs, $\overline{\text{CLOCK}}$ and $\overline{\text{CLOCK}}$ or by the internal pixel clock generated by the PLL on-board. The $\overline{\text{LOADIN}}$ control signal need only have a frequency synchronous relationship to the pixel $\overline{\text{CLOCK}}$ (see “Pipeline Delay & On-Board Calibration” section). A completely phase independent $\overline{\text{LOADIN}}$ signal can be used with the ADV7160/ADV7162, allowing the $\overline{\text{CLOCK}}$ to occur anywhere during the $\overline{\text{LOADIN}}$ cycle.

Alternatively, the $\overline{\text{LOADOUT}}$ signal of the ADV7160/ADV7162 can be used. $\overline{\text{LOADOUT}}$ can be connected either directly or indirectly to $\overline{\text{LOADIN}}$. Its frequency is automatically set to the correct $\overline{\text{LOADIN}}$ requirement.

$\overline{\text{SYNC}}$, $\overline{\text{BLANK}}$

The $\overline{\text{BLANK}}$ and $\overline{\text{SYNC}}$ video control signals drive the analog outputs to the Blank and Sync levels respectively. These signals are latched into the part on the rising edge of $\overline{\text{LOADIN}}$. The $\overline{\text{SYNC}}$ information is encoded onto the $\overline{\text{IOG}}$ analog signal when Bit CR22 of Command Register 2 is set to “1,” the $\overline{\text{IOR}}$ analog signal when Bit CR41 of Command Register 4 is set to “1” and the $\overline{\text{IOB}}$ analog signal when Bit CR42 of Command Register 4 is set to “1.” The $\overline{\text{SYNC}}$ input is ignored if CR22, CR41 and CR42 are set to logic “0.”

$\overline{\text{SYNCOUT}}$

In some applications where it is not permissible to encode $\overline{\text{SYNC}}$ on green ($\overline{\text{IOG}}$), blue ($\overline{\text{IOB}}$), or red ($\overline{\text{IOR}}$), $\overline{\text{SYNCOUT}}$ can be used as a separate TTL digital $\overline{\text{SYNC}}$ output. This has the advantage over an independent (of the ADV7160/ADV7162) $\overline{\text{SYNC}}$ in that it does not necessitate knowing the absolute pipeline delay of the part. This allows complete independence between $\overline{\text{LOADIN}}$ /Pixel Data and $\overline{\text{CLOCK}}$. The $\overline{\text{SYNC}}$ input is connected to the device as normal with Bit CR22 of Command Register 2, Bit CR41 of Command Register 4 and Bit CR42 of Command Register 4 are set to “0” thereby preventing $\overline{\text{SYNC}}$ from being encoded onto $\overline{\text{IOG}}$, $\overline{\text{IOR}}$ and $\overline{\text{IOB}}$. The output signal generates a TTL $\overline{\text{SYNCOUT}}$ with correct pipeline delay which is capable of directly driving the composite $\overline{\text{SYNC}}$ signal of a computer monitor.

$\overline{\text{TRISYNC}}$

This input is used to generate a HDTV Sync on any of the DAC outputs. Bit CR17 of Command Register 1 is set to “1”, enabling $\overline{\text{TRISYNC}}$. When $\overline{\text{TRISYNC}}$ is low, the analog output which has Sync enabled goes to the tri-sync level.

$\text{PS0}_{\text{A-D}} - \text{PS1}_{\text{A-D}}$ (Palette Priority Select Inputs)

These multifunctional TTL compatible inputs can be configured for three separate functions. The eight PS inputs are multiplexed to provide two bits which are used to provide one of three different functions. The function is selected by Bit CR14 and Bit CR15 of Command Register 1.

CR15	CR14	Color Mode
0	0	Palette Select Mode
0	1	Bypass Mode Control (ADV7160 Only)
1	0	Overlay Color Mode
1	1	Ignore PS Inputs

However, in 8:1 Mode, for 8-Bit Pseudo Color, the unused Blue Pixel Inputs are used to provide 8 extra PS inputs. The bypass mode is unavailable in this case.

Palette Select Mode

These pixel port select inputs effectively determine whether the devices RGB analog outputs are turned-on or shut down. When the analog outputs are shut down, $\overline{\text{IOR}}$, $\overline{\text{IOG}}$ and $\overline{\text{IOB}}$ are forced to 0 mA regardless of the state of the pixel and control data inputs. This state is determined on a pixel by pixel basis as the $\text{PS0} - \text{PS1}$ inputs are multiplexed in exactly the same format as the pixel port color data. These controls allow for switching between multiple palette devices. If the values of PS0 and PS1 match the values programmed into bits MR16 and MR17 of the Mode Register, then the device is selected, if there is no match the device is effectively shut down.

Bypass Mode Control (ADV7160 Only)

In this mode PS1 is used to switch between one of the color modes through the Color Palette and one of the Palette Bypass modes on a pixel by pixel basis. The color mode through the palette is selected using Bits CR27–CR24 of Command Register 2. The Bypass Color Mode is selected using Bits CR17 and CR16 of Command Register 1. PS1 then switches between the Palette Color Mode, and the Bypass Color Mode. The PS0 input continues to act as an overlay input, allowing Overlay Color 1 to be displayed.

PS0	PS1	Color Mode
0	0	Palette Color Mode (CR27–CR24)
0	1	Bypass Color Mode (CR17–CR16)
1	x	Overlay Color 1

This mode is not available if using the ADV7162.

Overlay Color Mode

In this mode, the PS inputs provide control for a three color overlay. Whenever the value other than “00” is placed on the overlay inputs, the corresponding overlay color is displayed. When the overlay inputs contain “00” the color is specified by the main pixel inputs.

CLOCK CONTROL CIRCUIT

The ADV7160/ADV7162 has an integrated Clock Control Circuit (Figure 16). This circuit is capable of both generating the ADV7160/ADV7162’s internal clocking signals as well as external graphics subsystem clocking signals. Total system synchronization can be attained by using the parts output clocking signals to drive the controlling graphics processor’s master clock as well as the video frame buffers shift clock signals.

$\overline{\text{CLOCK}}$, $\overline{\text{CLOCK}}$ Inputs

The Clock Control Circuit is driven by the pixel clock inputs, $\overline{\text{CLOCK}}$ and $\overline{\text{CLOCK}}$. These inputs can be driven by a differential ECL oscillator running from a +5 V supply.

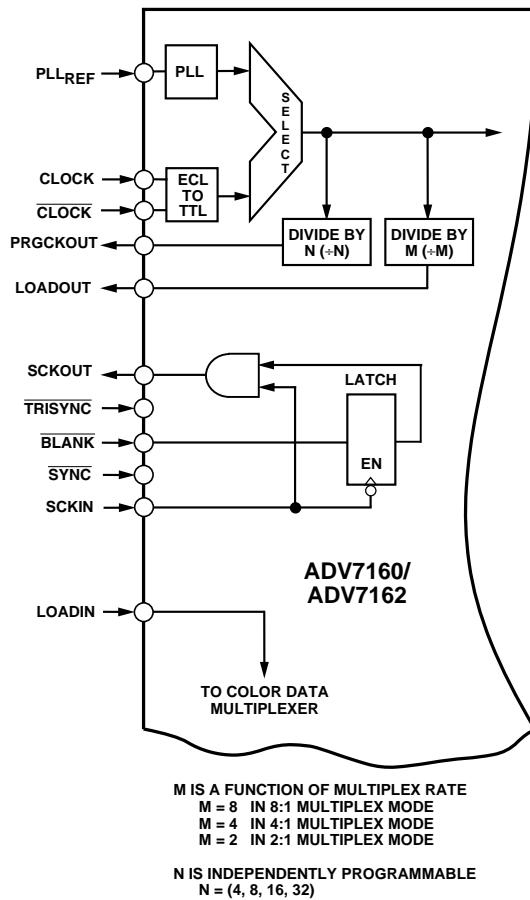

Figure 16. Clock Control Circuit of the ADV7160/ADV7162

CLOCK CONTROL SIGNALS

LOADOUT

The ADV7160/ADV7162 generates a LOADOUT control signal which runs at a divided down frequency of the pixel CLOCK. The frequency is automatically set to the programmed multiplex rate, controlled by CR37 and CR36 of Command Register 3.

$$\begin{aligned} f_{LOADOUT} &= f_{CLOCK}/8 && 8:1 \text{ multiplex mode} \\ f_{LOADOUT} &= f_{CLOCK}/4 && 4:1 \text{ multiplex mode} \\ f_{LOADOUT} &= f_{CLOCK}/2 && 2:1 \text{ multiplex mode} \end{aligned}$$

The LOADOUT signal is used to directly drive the LOADIN pixel latch signal of the ADV7160/ADV7162. This is most simply achieved by tying the LOADOUT and LOADIN pins together. Alternatively, the LOADOUT signal can be used to drive the frame buffer's shift clock signals, returning to the LOADIN input delayed with respect to LOADOUT.

If it is not necessary to have a known fixed number of pipeline delays, then there is no limitation on the delay between LOADOUT and LOADIN (LOADOUT(1) and LOADOUT(2)). LOADIN and Pixel Data must conform to the setup and hold times (t_8 and t_9).

If however, it is required that the ADV7160/ADV7162 has a fixed number of pipeline delays (t_{PD}) LOADOUT and LOADIN must conform to timing specifications t_{10} and $\tau-t_{11}$ as illustrated in Figures 5 to 10.

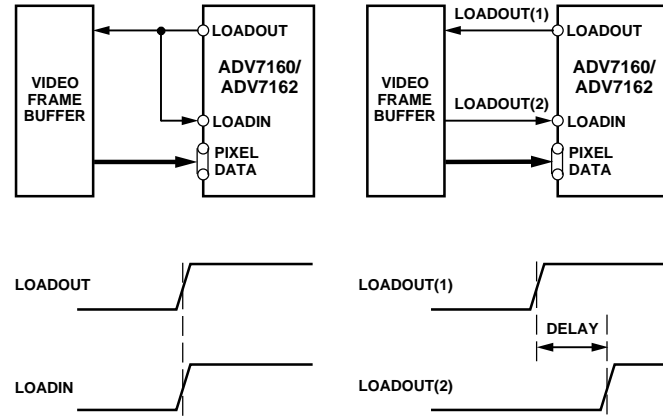

Figure 17. LOADOUT vs Pixel Clock

Pipeline Delay and Onboard Calibration

The ADV7160/ADV7162 has a fixed number of pipeline delays (t_{PD}), so long as timings t_{10} and $\tau-t_{11}$ are met. However, if a fixed number of pipeline delays is not a requirement, timings t_{10} and $\tau-t_{11}$ can be ignored, a calibration cycle must be run and there is no restriction on LOADIN to LOADOUT timing. If timings t_{10} and $\tau-t_{11}$ are not met, the part will function correctly though with an increased number of pipeline delays. The ADV7160/ADV7162 has on-board calibration circuitry which synchronizes pixel data and LOADIN with the internal ADV7160/ADV7162 clocking signals. Calibration can be performed in two ways. During the device's initialization sequence by toggling two bits of the Mode Register, MR10 followed by MR15 or by writing a "1" to Bit CR10 of Command Register 1 and a "0" to MR15 which executes a calibration on every Vertical Sync.

PRGCKOUT

The PRGCKOUT control signal outputs a user programmable clock frequency. It is a divided down frequency of the pixel CLOCK (see Figure 11). The rising edge of PRGCKOUT is synchronous to the rising edge of LOADOUT.

$$f_{PRGCKOUT} = f_{CLOCK}/N$$

where $N = 4, 8, 16$ or 32 .

One application of the PRGCKOUT is to use it as the master clock frequency of the graphics subsystems processor or controller.

SCKIN, SCKOUT

These video memory signals are used to minimize external support chips. Figure 18 illustrates the function that is provided. An input signal applied to SCKIN is synchronously AND-ed with the video blanking signal (\overline{BLANK}). The resulting signal is output on SCKOUT. Figure 12 of the Timing Waveform section shows the relationship between SCKOUT, SCKIN and BLANK.

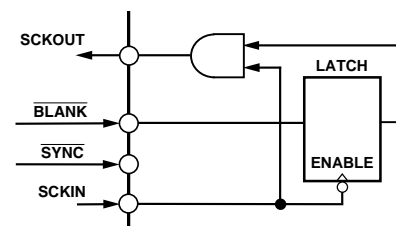

Figure 18. SCKOUT Generation Circuit

ADV7160/ADV7162

The SCKOUT signal is essentially the video memory shift control signal. It is stopped during the screen retrace. Figure 19 shows a suggested frame buffer to ADV7160/ADV7162 interface. This is a minimum chip solution and allows the ADV7160/ADV7162 control the overall graphics system clocking and synchronization.

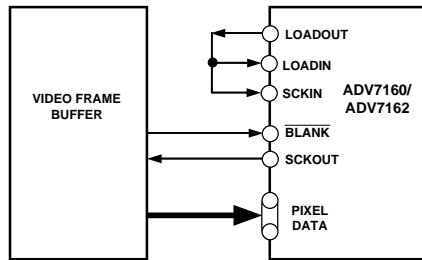

Figure 19. ADV7160/ADV7162 Interface Using SCKIN and SCKOUT

PLL

The on-board PLL can be used as an alternative clock source. This eliminates the need for an external high speed clock generator such as a crystal oscillator. With the PLL, it is possible to generate an internal clock whose frequency is a multiple of the PLL reference frequency (PLL_{REF}). Internal PLL operation is selected by setting CR56 of Command Register 5 to Logic “1.” The PLL registers can be programmed to set up the frequency required.

The block diagram of the Phase Locked Loop is shown in Figure 20. The blocks consist of a phase frequency detector, a charge pump, a loop filter, a voltage controlled oscillator and a programmable divider.

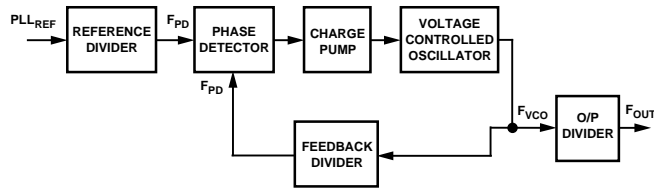

Figure 20. PLL Block Diagram

The phase frequency detector drives the voltage controlled oscillator (VCO), to a frequency that will cause the two inputs to the phase frequency detector to be matched in frequency and phase. The corresponding output of the VCO can be calculated as:

$$VCO = PLL_{REF} \frac{\text{Feedback Divider}}{\text{Reference Divider}}$$

The Reference Divider is set by a combination of the contents of the PLL R Register and the RSEL bit. The PLL R Register has a resolution of 7 bits. It is programmed by setting the PLL R Register located at Control Register address 00CH. The PLL R Register can be set from 01H to 7FH. It should not be set to 00H. If this register contains 00H, then the PLL stops. Therefore, the Reference Divider can be set from 3 to 129 in steps of one, or from 130 to 258 in steps of two by setting the RSEL bit. The RSEL bit is accessed by changing Bit PCR1 of the PLL Control Register. The Feedback Divider is set by a combination of the contents of the PLL V Register, the VSEL bit and the S value. The S value is set up in PCR7 and PCR6 of the PLL Command Register. This S value allows a better resolution when setting the Feedback Divider value. The PLL V Register has a resolution of 7 bits. It is programmed by setting the PLL V Register located at Control Register address 00FH. The

PLL V Register can be set from 01H to 7FH. It should not be set to 00H. If this register contains 00H, then the PLL stops. Therefore the feedback divider can be set from 12 to 519 in steps of one, or from 520 to 1038 in steps of two by setting the VSEL bit. The VSEL bit is accessed by changing bit PCR2 of the PLL Control Register. The P counter divides the output from the oscillator by 1, 2, 4 or 8 as determined by PSEL1 and PSEL0 which are set in bits PCR5 and PCR4 of the PLL Control Register. This post-scaler is useful in the generation of lower frequencies as the VCO has been optimized for high frequency operation.

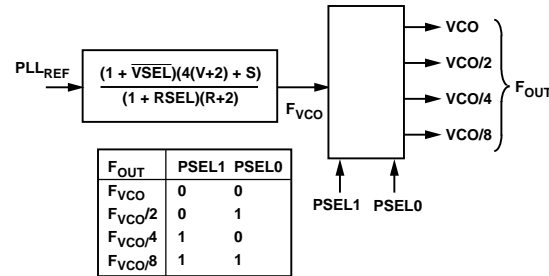

Figure 21. PLL Transfer Function

The transfer function of the PLL can be summarized by the block diagram shown in Figure 21.

To optimize the performance of the on-board PLL, the following criteria should be followed:

- 900 kHz < PLL_{REF} < 40 MHz
- 300 kHz < F_{PD} < 10 MHz
- 120 MHz < F_{VCO} < 260 MHz

For $F_{VCO} > 220$ MHz, V_{SEL} should be programmed to logic “0.”

Any lower frequency output can be achieved by using the output divider.

A jitter performance graph as a function of both F_{PD} and F_{VCO} is illustrated in Figure 22. It can be seen that jitter decreases with increasing F_{VCO} and also that jitter decreases with increasing F_{PD} . For each F_{OUT} , the user should firstly maximize F_{VCO} using the output divider and then pick PLL_{REF} and reference divide to maximize F_{PD} . When generating multiple output frequencies from one PLL_{REF} value, an iterative process should be used to find the PLL_{REF} value that gives the best trade off between jitter performance and F_{OUT} accuracy.

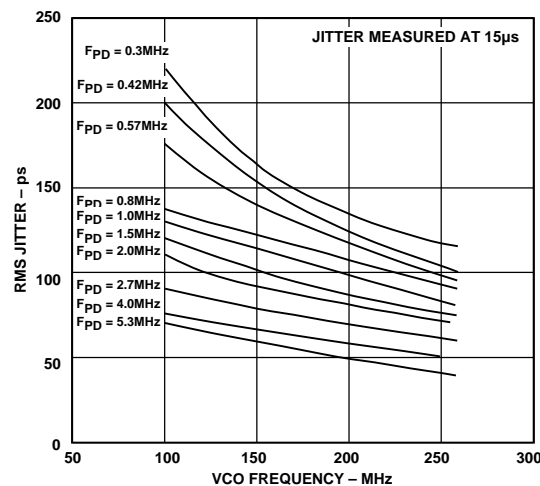

Figure 22. PLL Jitter

COLOR VIDEO MODES

The ADV7160/ADV7162 supports a number of color video modes all at the maximum video rate.

Command bits CR27–CR24 of Command Register 2 along with bit MR11 of Mode Register 1 determine the color mode. Seven color modes use the Color Palette, and three of them bypass the palette and control the DACs directly.

24-Bit True Color

(CR27, CR26, CR25, CR24 = 1, 1, 1, 0)

The part is set to 24-bit/30-bit “Gamma” True-Color operation with MR11 set to Logic “1” and direct 24-bit True-Color operation with MR11 set to Logic “0.” The pixel port accepts 24 bits of color data which is directly mapped to the Look-Up Table RAM. With MR11 set to Logic “1,” the Look-Up Table is configured as a 256 location by 30 bits deep RAM (10 bits each for Red, Green and Blue), the RAM is preloaded with a user determined, nonlinear function, such as a gamma correction curve and the output of the RAM drives the DACs with 30-bit data. With MR11 set to Logic “0,” the Look-Up Table is configured as a 256 location by 24 bits deep RAM (8 bits each for Red, Green and Blue), the RAM is preloaded with a linear function and the output of the RAM drives the DACs with 24-bit data.

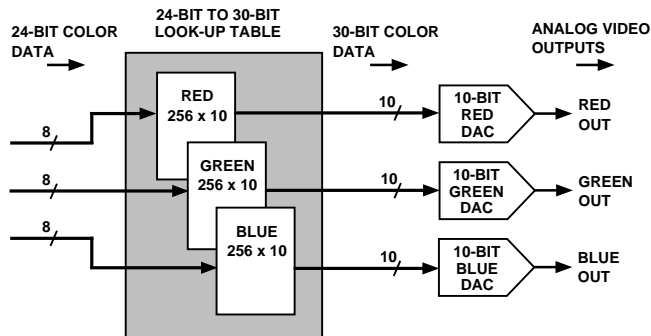

Figure 23. 24-Bit to 30-Bit True-Color Configuration

16-Bit True Color

(CR27, CR26, CR25, CR24 = 1, 0, 1, 1)

The part is set to 16-bit True-Color operation. The pixel port accepts 16 bits of color data which is mapped to the 5 LSBs of each of the red and blue palettes of the Look-Up-Table RAM, and 6 LSBs of the green palette of the Look-Up-Table RAM. With MR11 set to Logic “1,” the Look-Up Table is configured as a 64 location by 30 bits deep RAM (10 bits each for Red, Green and Blue) and the output of the RAM drives the DACs with 30-Bit data, allowing the display of 16-bit Gamma-Corrected True-Color Images. With MR11 set to Logic “0,” the Look-Up Table is configured as a 64 location by 24 bits deep RAM (8 bits each for Red, Green and Blue); and the output of the RAM drives the DACs with 24-bit data, allowing the display of 16-bit True-Color Images.

15-Bit True Color

(CR27, CR26, CR25, CR24 = 1, 1, 0, 0 or 1, 1, 0, 1)

The part is set to 15-bit True-Color operation. The pixel port accepts 15 bits of color data which is mapped to the 5 LSBs of each of the red, green and blue palettes of the Look-Up Table RAM. With MR11 set to Logic “1,” the Look-Up Table is configured as a 32 location by 30 bits deep RAM (10 bits each for Red, Green and Blue) and the output of the RAM drives the

DACs with 30-bit data, allowing the display of 15-bit Gamma-Corrected True-Color Images. With MR11 set to Logic “0,” the Look-Up Table is configured as a 32 location by 24 bits deep RAM (8 bits each for Red, Green and Blue) and the output of the RAM drives the DACs with 24-bit data, allowing the display of 15-bit True-Color Images.

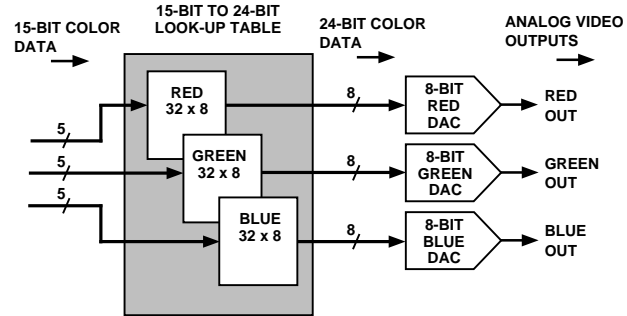

Figure 24. 15-Bit to 24-Bit True-Color Configuration

8-Bit Pseudo Color

(CR27, CR26, CR25, CR24 = 0, 0, 0, 0 or 0, 1, 0, 0 or 1, 0, 0, 0)

This mode sets the part into 8-bit Pseudo-Color operation. The pixel port accepts 8 bits of pixel data, from either the red, blue or green channel. With MR11 set to Logic “1,” a 30-bit word is indexed in the Look-Up Table RAM. The Look-Up Table is configured as a 256 location by 30 bits deep RAM (10 bits each for Red, Green and Blue). The output of the RAM drives the DACs with 30-bit data. With MR11 set to Logic “0,” a 24-bit word is indexed in the Look-Up Table RAM. The Look-Up Table is configured as a 256 location by 24 bits deep RAM (8 bits each for Red, Green and Blue). The output of the RAM drives the DACs with 24-bit data. This mode allows for the display of 256 simultaneous colors out of a total palette of millions of addressable colors.

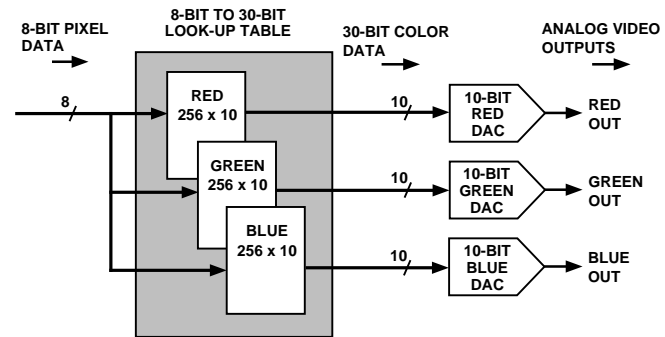

Figure 25. 8-Bit to 30-Bit Pseudo-Color Configuration

PIXEL PORT MAPPING

The pixel data to the ADV7160/ADV7162 is automatically mapped in the parts pixel port as determined by the pixel data mode programmed (Bits CR27–CR24 of Command Register 2).

Pixel data in the 24-bit True-Color modes is directly mapped to the 24 color inputs R7–R0, G7–G0 and B7–B0.

There is one mode of operation for 16-bit True Color. Data is input to the device over the red and green color ports (R7–R0 and G7–G0) and is internally mapped to LUT Locations 0–63 according to Figure 26. (Note: Data on unused pixel inputs is ignored.)

ADV7160/ADV7162

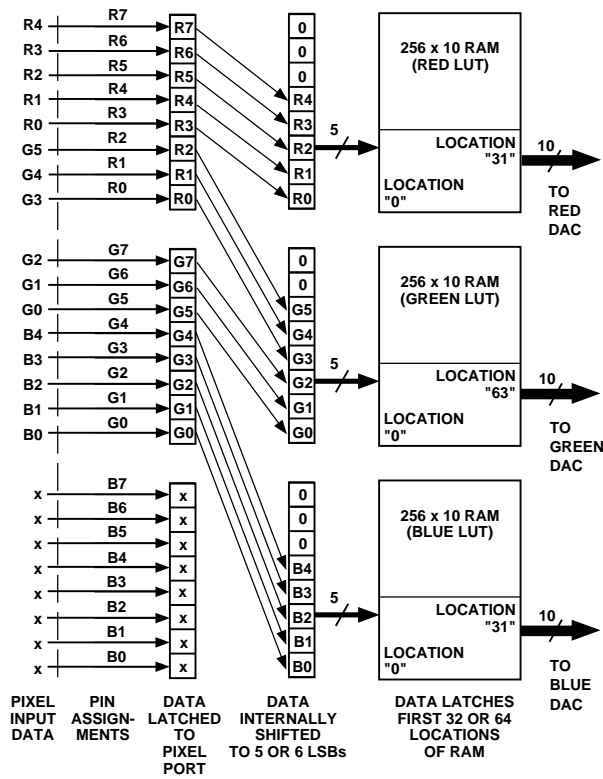

Figure 26. 16-Bit True-Color Mapping using R7-R0 and G7-G0

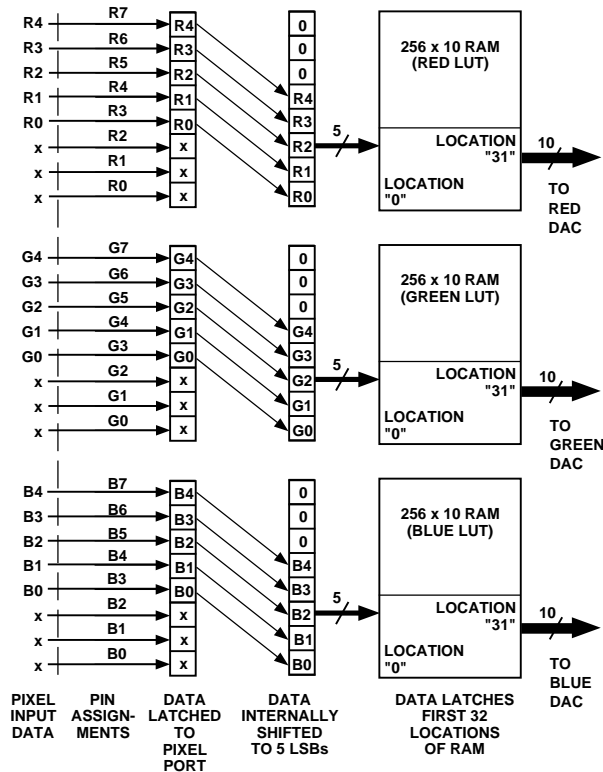

Figure 27. 15-Bit True Color Mapping using R7-R3, G7-G3 and B7-B3

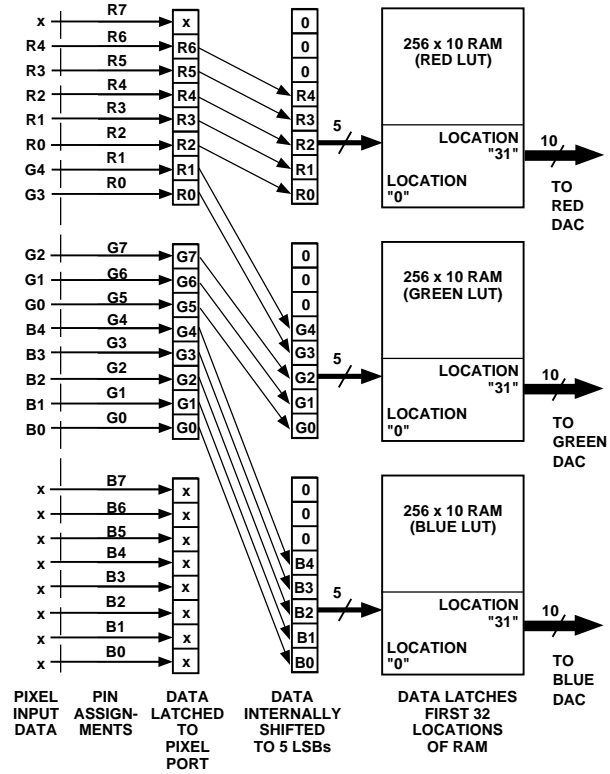

Figure 28. 15-Bit True-Color Mapping using R6-R0 and G7-G0

The part has two modes of operation for 15-bit True Color. In the first mode, data is input to the device over the red, green and blue channel (R7-R3, G7-G3 and B7-B3) and is internally mapped to Locations 0 to 31 of the Look-Up Table (LUT) according to Figure 27.

In the second mode, data is input to the device over just two of the color ports, red and green (R7-R0 and G7-G0) and is internally mapped to LUT Locations 0 to 31 according to Figure 30. (Note: Data on unused pixel inputs is ignored.)

There are three modes of operation for 8-bit Pseudo Color. Each mode maps the input pixel data differently. Data can be input into one of the three color channels, R7-R0 or G7-G0 or B7-B0.

In 24-bit Palette Bypass Mode, the red, blue and green color channels bypass the Pixel Mask and the Color Palette. Each 8-bit color channel is mapped onto the 8 MSBs of the corresponding 10-bit DAC input. The two LSBs on each DAC are zeros. The Bypass Mode can be selected in two ways, by using CR27-CR24 of Command Register 2 or on a pixel by pixel basis using the PS inputs (ADV7160 only).

In 16-bit Palette Bypass Mode, the color channels bypass the Pixel Mask and the Color Palette. The 8-bits of red pixel data and 8-bits of green pixel data are mapped onto the 5 MSBs of the red and blue DAC input and the 6 MSBs of the green DAC input as shown in Figure 29. The remaining LSBs on each DAC are zeros. The Bypass Mode can be selected in two ways, by using CR27-CR24 of Command Register 2 or on a pixel by pixel basis using the PS inputs (ADV7160 only).

ADV7160/ADV7162

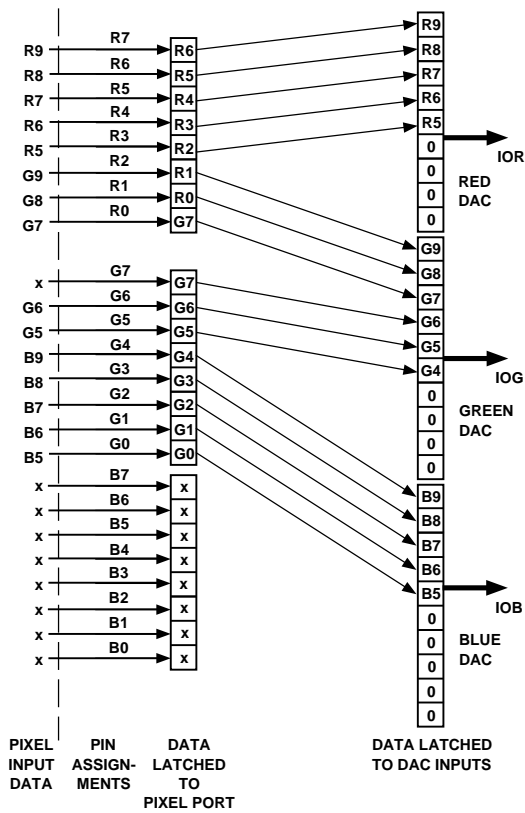

Figure 29. 16-Bit True-Color in Bypass Mode using R7-R0 and G7-G0

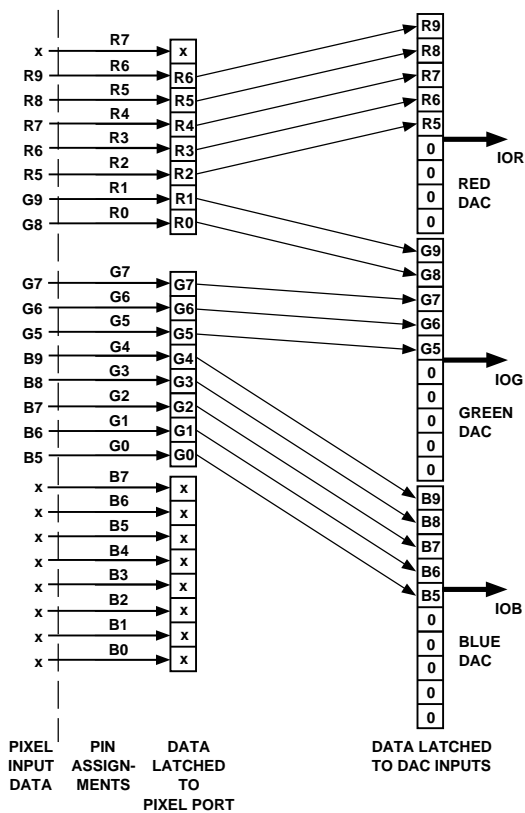

Figure 30. 15-Bit True-Color in Bypass Mode using R6-R0 and G7-G0

In 15-bit Palette Bypass Mode, the color channels bypass the Pixel Mask and the Color Palette. The 7 bits of red pixel data and 8 bits of green pixel data are mapped onto the 5 MSBs of the red, green and blue DAC input as shown in Figure 30. The remaining LSBs on each DAC are zeros. The Bypass Mode can be selected in two ways, by using CR27–CR24 of Command Register 2 or on a pixel by pixel basis using the PS inputs (ADV7160 only).

Multiplexing

The on-board multiplexers of the ADV7160/ADV7162 eliminate the need for external data serializer circuits. Multiple video memory devices can be connected, in parallel, directly to the device. Figure 31 shows four memory banks of 50 MHz memory connected to the ADV7160, running in 4:1 multiplex mode, giving a resultant pixel or dot clock rate of 200 MHz. Instead of having to provide a new pixel at the input every 5 ns, four pixels are provided together every 20 ns. The input multiplexer takes the four pixels latched in parallel, and selects them one at a time to produce a pixel stream at the pixel clock rate. In 4:1 mode, the pixels are selected in the sequence A, B, C, D, cycling continuously. In 2:1 mode, the A and B pixels are selected. The 8:1 mode is only available in 8-bit Pseudo-Color Mode. BLANK, SYNC, ODD/EVEN and TRISYNC are not multiplexed and can only change on a 1, 2, 4 or 8 pixel boundary depending on the multiplex mode.

On the rising edge of LOADIN, all the pixel port inputs are latched into the ADV7160/ADV7162. The LOADIN frequency must be a divided down frequency of the pixel clock frequency. This can be achieved using LOADOUT to directly drive LOADIN as LOADOUT provides the correct frequency required, or drive LOADIN after delay through some external circuitry.

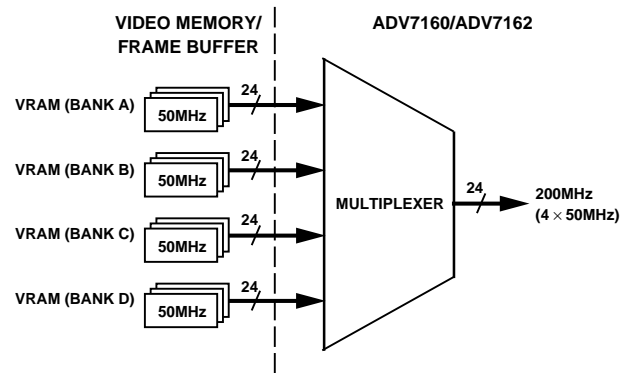

Figure 31. Direct Interfacing of Video Memory to ADV7160/ADV7162

8-Bit Pseudo Color in 8:1 Multiplexing Mode

When 8:1 Multiplexing Mode is selected by setting Bit CR37 of Command Register 3 to Logic “1” and bit CR36 of Command Register 3 to Logic “0,” the ADV7160/ADV7162 goes into 8-Bit Pseudo-Color Mode irrespective of the Color Mode selected by Bits CR27 to CR24 in Command Register 2. Hence LOADOUT operates at $f_{CLOCK}/8$. Eight 8-bit pixels are latched in parallel by the rising edge of LOADIN. These 8-bit pixels are then selected, one at a time, to produce an 8-bit pixel stream which passes through the Pixel Mask to address the LUT. The order the eight 8-bit pixels are displayed is GA, RA, GB, RB, GC, RC, GD, RD.

ADV7160/ADV7162

The unused Blue pixel inputs are used, in this mode, to provide 8 extra PS inputs. These PS inputs provide 2 bits after 8:1 multiplexing. The PS inputs can be used as Overlay or Palette Select inputs.

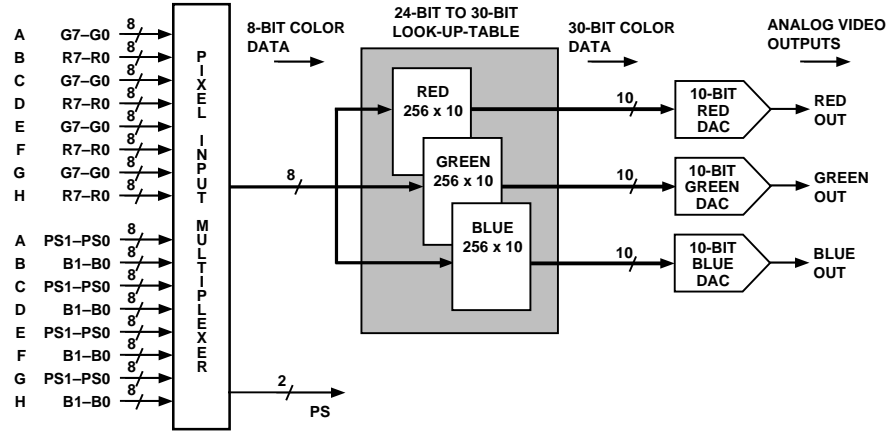

Figure 32. 8-Bit Pseudo Color in 8:1 Multiplexing Mode

MICROPROCESSOR (MPU PORT)

The ADV7160/ADV7162 supports a standard MPU Interface. All the functions of the part are controlled via this MPU port. Direct access is gained to the Address Register, Mode Register and all the Control Registers as well as the Color Palette. The following sections describe the setup for reading and writing to all of the devices registers.

MPU Interface

The MPU interface (Figure 33) consists of a bidirectional, 10-bit wide databus and interface control signals \overline{CE} , $C0$, $C1$ and R/\overline{W} . The 10-bit wide databus is user configurable as illustrated.

Table I. Data-Bus Width

Data-Bus Width	RAM/DAC Resolution	Read/Write Mode
10-Bit	10-Bit	10-Bit Parallel
10-Bit	8-Bit	8-Bit Parallel
8-Bit	10-Bit	8 + 2 Byte
8-Bit	8-Bit	8-Bit Parallel

Register Mapping

The ADV7160/ADV7162 contains a number of on-board registers including the Mode Register (MR17–MR10), Address Register (A10–A0) and many Control Registers as well as Color Palette Registers. These registers control the entire operation of the part. Figure 34 shows the internal register configuration.

Control lines $C1$ and $C0$ determine which register the MPU is accessing. $C1$ and $C0$ also determine whether the Address Register is pointing to the color registers and Look-Up Table RAM or the control registers. If $C1, C0 = 1, 0$ the MPU has access to whatever control register is pointed to by the Address Register (A10–A0). If $C1, C0 = 0, 1$ the MPU has access to the Look-Up Table RAM (Color Palette) or the Overlay Palette through the associated color registers. The \overline{CE} input latches data to or from the part.

The R/\overline{W} control input determines between read or write accesses. The truth tables show all modes of access to the various registers and color palette for both the 8-bit wide databus configuration and 10-bit wide data bus configuration. It should be noted that after power-up, the devices MPU port is automatically set to 10-bit wide operation (see Power-On Reset section).

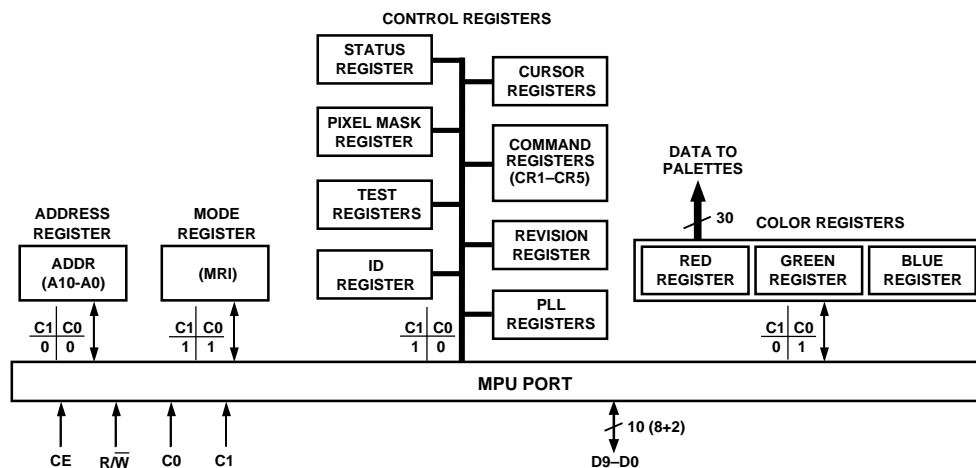

Figure 33. MPU Port and Register Configuration

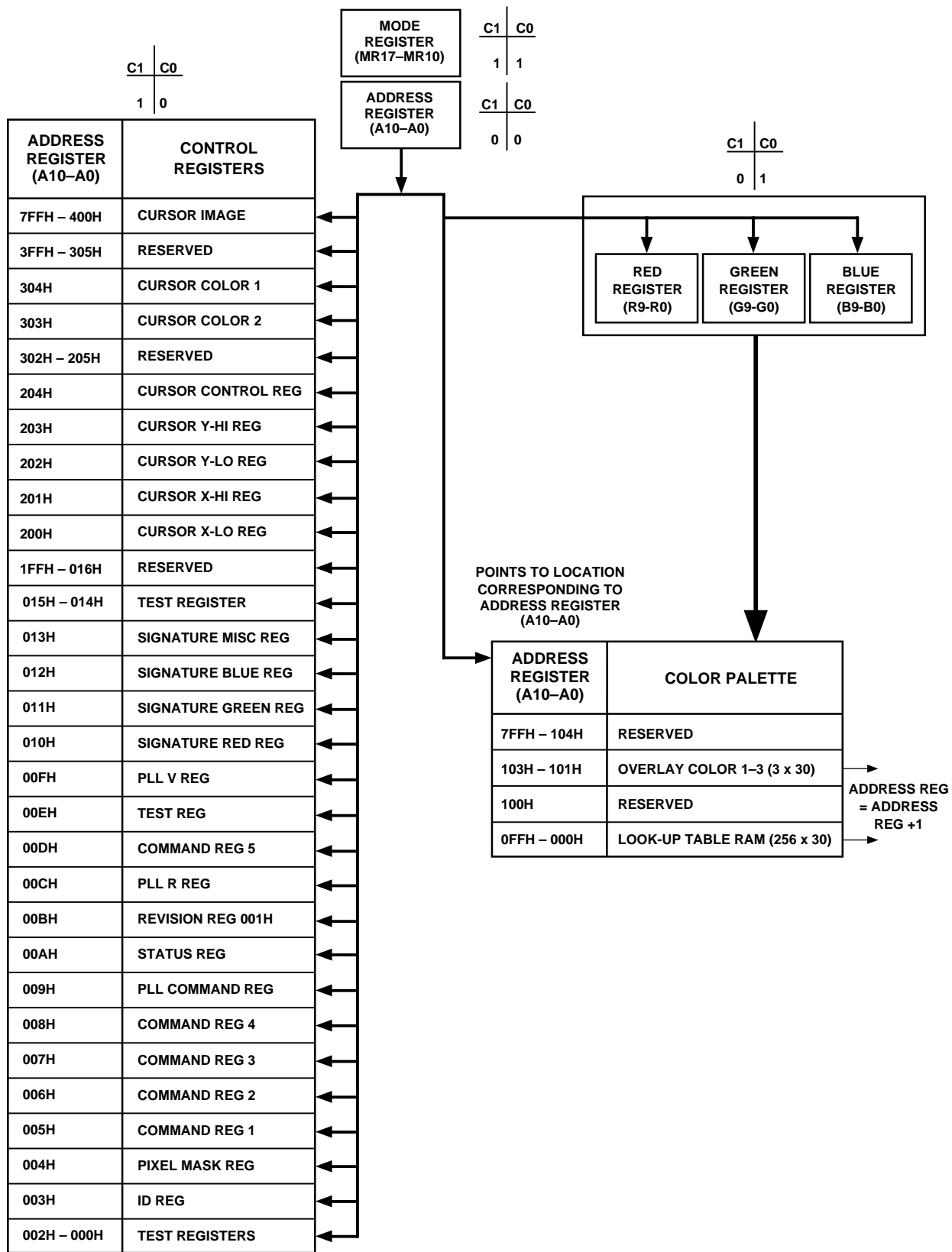

Figure 34. Internal Register Configuration and Address Decoding

ADV7160/ADV7162

Power-On Reset

On power-up, the ADV7160/ADV7162 executes a power-on reset operation. This initializes the pixel port such that the pixel sequence ABCD starts at A. The Mode Register (MR17–MR10), Command Register 2 (CR27–CR20), Command Register 3 (CR37–CR30) have all bits set to a Logic “1” and Address Register, Command Register 1 (CR17–CR10), Command Register 4 (CR47–CR40) and Command Register 5 (CR57–CR50) have all bits set to a Logic “0.”

The output clocking signals are also set during this reset period.

$$\text{PRGCKOUT} = \text{CLOCK}/32$$

$$\text{LOADOUT} = \text{CLOCK}/4:$$

The power-on reset is activated when V_{AA} goes from 0 V to 5 V. This reset is active for 1 μ s. The ADV7160/ADV7162 should not be accessed during this reset period. The pixel clock should be applied at power-up.

Color Palette Accesses

The Color Palette consists of 256 RAM locations, each location containing 30 bits of color information. Data is written to the color palette by firstly writing to the address register of the color palette location to be modified. The MPU performs three successive write cycles for each of the red, green and blue registers (10-bit or 8-bit). Figures 35 to 38 illustrate write operations for a 10-bit databus using the DACs in 8-bit and 10-bit mode and write operations for an 8-bit databus using the DACs in 8-bit and 10-bit mode. An internal pointer moves from red to green to blue after each write is completed. This pointer is reset to red after a blue write or whenever the address register is written. During the blue write cycle, the three bytes of red, green and

blue are concatenated into a single 30-bit/24-bit word and written to the RAM location as specified in the address register (A10–A0).

The address register then automatically increments to point to the next RAM location and a similar red, green and blue palette write sequence is performed. The address register resets to 000H following a blue write cycle to color palette RAM location 0FFH. The three color overlay palette is located in address space above the main color palette. To access the Overlay Palette, the Address Register must first be written with address 101H. From then on, the colors are accessed in the same way as the main Color Palette, with the Address Register incrementing after each blue access.

Data is read from the Color Palette by firstly writing to the address register of the color palette location to be read. The MPU performs three successive read cycles from each of the red, green and blue locations (10-bit or 8-bit) of the RAM. Figures 35 to 38 illustrate read operations for a 10-bit databus using the DACs in 8-bit and 10-bit mode and read operations for an 8-bit databus using the DACs in 8-bit and 10-bit mode. An internal pointer moves from red to green to blue after each read is completed. This pointer is reset to red after a blue read or whenever the address register is written. The address register then automatically increments to point to the next RAM location and a similar red, green and blue palette read sequence is performed. The address register resets to 000H following a blue read cycle of color palette RAM location 0FFH. Similarly for the Overlay Palette, the Address Register must first be written with address 101H. From then on, the colors are read in the same way as the main Color Palette, with the Address Register incrementing after each blue access.

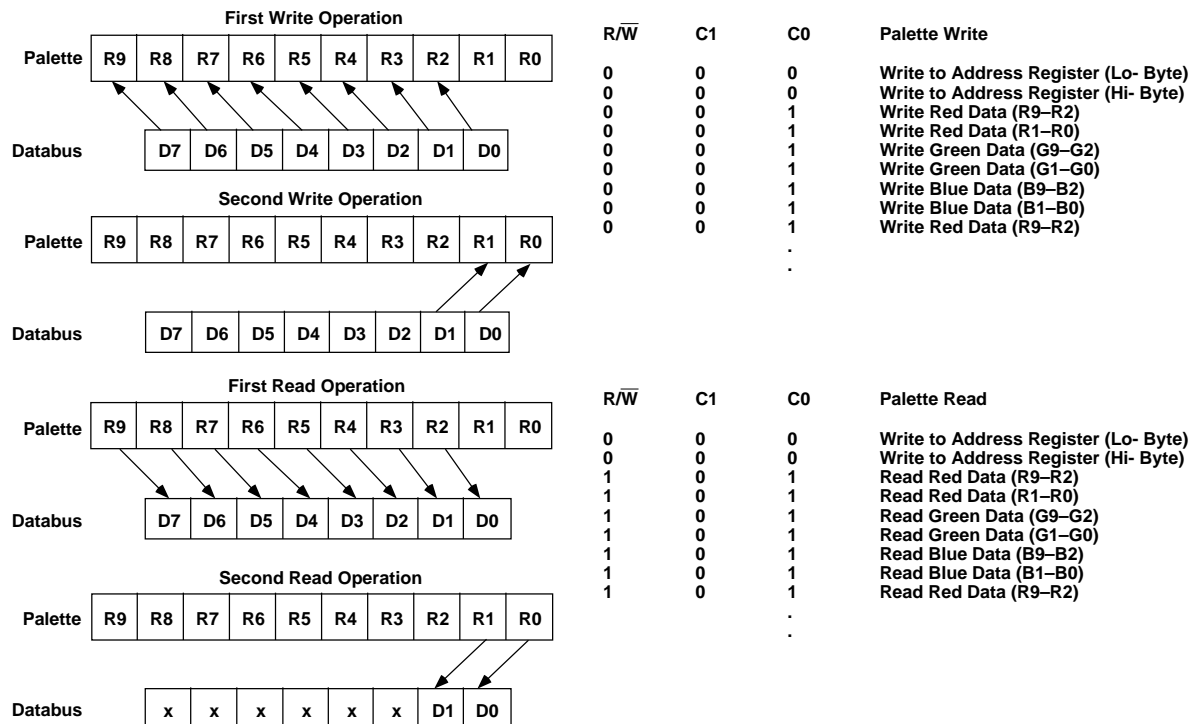

Figure 35. 8-Bit Data Bus Using 10-Bit DACs

ADV7160/ADV7162

REGISTER PROGRAMMING

The following section describes each register, including Address Register, Mode Register and each of the Control Registers in terms of its configuration.

Address Register (A10–A0)

As illustrated in the previous tables, the C1 and C0 control inputs, in conjunction with this address register specify which control register, or color palette location is accessed by the MPU port. The Address Register is 11 bits wide and can be read from as well as written to. To access the Address Register, two consecutive MPU accesses with C1 and C0 set to Logic “0” are required. The first one accesses the low byte; and when a second access of the same type is performed, i.e., two consecutive reads or two consecutive writes, the high byte is accessed. If the type of access is changed, or if an access to a different register is inserted between the first and the second, then the second access will access the low byte again. When writing to or reading from the color palette on a sequential basis, only the start address needs to be written. After a red, green and blue write sequence, the address register is automatically incremented.

Mode Register (MR1)

The mode register is a 10-bit wide register. However for programming purposes, it may be considered as an 8-bit wide register (MR19 and MR18 are both reserved). It is denoted as MR17–MR10 for simplification purposes.

Figure 39 shows the various operations under the control of the mode register. This register can be read from as well written to. In read mode, if MR19 and MR18 are read back, they are both returned as zeros.

MODE REGISTER BIT DESCRIPTION

Reset Control (MR10)

This bit is used to reset the pixel port sampling sequence. This ensures that the pixel sequence ABCD starts at A. It is reset by writing a “1” followed by a “0” followed by a “1.” This bit must run this cycle during the initialization sequence.

RAM-DAC Resolution Control (MR11)

When this is programmed with a “1,” the RAM is 30 bits deep (10 bits each for red, green and blue), and each of the three DACs is configured for 10-bit resolution. When MR11 is programmed with a “0,” the RAM is 24 bits deep (8 bits each for red, green and blue), and the DACs are configured for 8-bit resolution. The two LSBs of the 10-bit DACs are pulled down to zero in 8-bit RAM-DAC mode.

MPU Data Bus Width (MR12)

This bit determines the width of the MPU port. It is configured as either a 10-bit wide (D9–D0) or 8-bit wide (D7–D0) bus. Ten-bit data can be written to the device when configured 8-bit wide mode. The 8 MSBs are first written on D7–D0, then the two LSBs are written over D1–D0. Bits D9–D8 are zeros in 8-bit mode.

Operational Mode Control (MR14–MR13)

When MR14 and MR13 are “0” the part operates in normal mode.

Calibrate LOADIN (MR15)

This bit automatically calibrates the on-board LOADIN/LOADOUT synchronization circuit. A “0” to “1” transition initiates calibration. This bit is set to “0” in normal operation. See “Pipeline Delay & Calibration” section. This bit must run this cycle during the initialization sequence.

Palette Select Match Bits Control (MR17–MR16)

These bits allow multiple palette devices to work together. When bits PS1 and PS0 match MR17 and MR16 respectively, the device is selected. If these bits do not match, the device is not selected and the analog video outputs drive 0 mA. See “Palette Priority Select Inputs” section.

CONTROL REGISTERS

A large bank of registers plus the 64 × 64 cursor image can be accessed through the Control Register. Access is made first by writing the Address Register with the appropriate address to point to the particular Control Register (see Figure 34), and

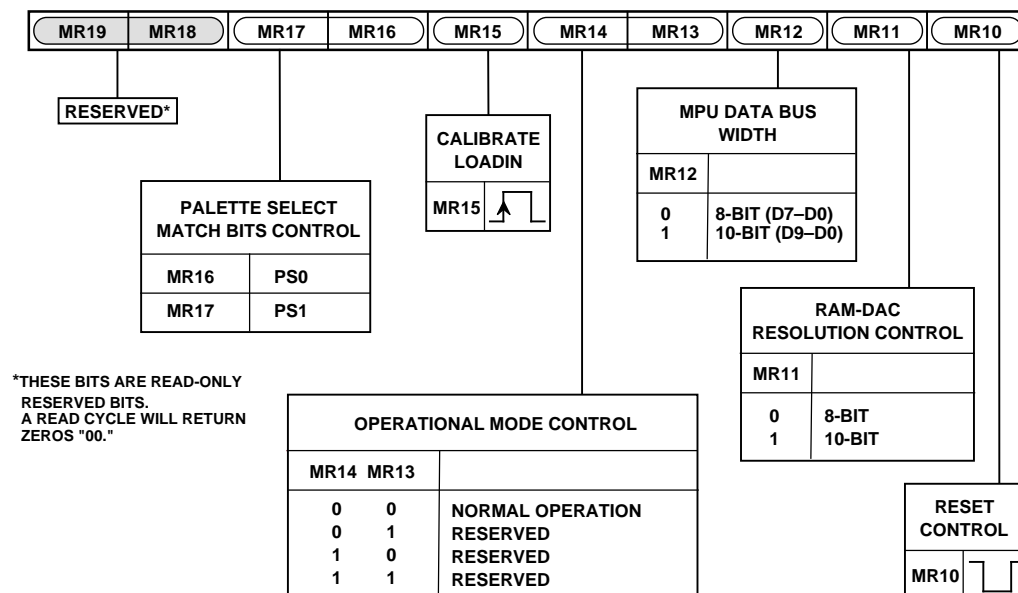

Figure 39. Mode Register 1 (MR1) (MR19–MR10)

then performing an MPU access to the Control Register. When accessing Control Registers in the range 200H to 204H, and when accessing the cursor image, the Address Register auto-increments after each register access. On accessing the last cursor image location at address 7FFH, the address register reverts to address 000H. The Address Register also auto-increments after a blue access, when accessing color registers in the address range 303H to 304H.

ID Register

(Address Reg (A10–A0) = 003H)

This is an 8-bit wide “Identification” read-only register. For the ADV7160 it will always return the hexadecimal value 76H. For the ADV7162 it will always return the hexadecimal value 79H.

Pixel Mask Register

(Address Reg (A10–A0) = 004H)

The contents of the pixel mask register are individually bit-wise logically ANDed with the Red, Green and Blue pixel input stream of data. It is an 8-bit read/write register with D0 corresponding to R0, G0 and B0. For normal operation, this register is set with FFH.

COMMAND REGISTER 1 (CR1)

(Address Reg (A10–A0) = 005H)

This register contains a number of control bits as shown in the diagram. CR1 is a 10-bit wide register. However for programming purposes, it may be considered as an 8-bit wide register (CR19 to CR18 reserved).

Figure 40 shows the various operations under the control of CR1. This register can be read from as well written to. In write mode zero should be written to CR12. In read mode, CR19 and CR18 are returned as zeros.

COMMAND REGISTER 1-BIT DESCRIPTION

Calibration Control (CR10)

This bit automatically calibrates the on-board LOADIN/LOADOUT synchronization circuit on every vertical Sync. MR15 of Mode Register MR1 must be set to “0.”

Hi-Byte Control (CR13)

This bit enables access to the Hi Byte of the Address Register. When CR13 is set to Logic “0”, the part is compatible to the ADV7150. To access the hi-byte of the address register, this bit is set to Logic “1.”

PS Function Control (CR15–CR14)

These bits control the functions of the PS inputs. They are used to enable the Overlay Mode, Bypass Mode or the Palette Select Mode. In Palette Select Mode (CR15 and CR14 = “0”), these inputs are used to multiplex the RGB outputs of a number of devices. On a pixel by pixel basis, PS1 and PS0 are compared against the PS match bits, MR17 and MR16. If they match, then the part behaves normally. If they don’t match, then the analog output currents are switched to zero for that clock cycle, thus allowing another device, whose PS match bits match during this time, to drive the monitor. In Bypass Mode (CR15 = “0,” CR14 = “1”), PS1 is used to switch between one of the color modes through the Color Palette and one of the Palette Bypass Modes, on a pixel by pixel basis. The color mode through the palette is selected using CR17 and CR16. It is illegal to program CR27 to CR24 to select one of the bypass modes when using the PS bits to select a bypass mode at the pixel rate. This switching on a pixel by pixel basis is only allowed when using an ADV7160 device. Therefore, for the ADV7162, this mode (CR15 = “0,” CR14 = “1”), is reserved and should not be used.

In Overlay Mode (CR15 = “1,” CR14 = “0”), the PS inputs provide control for a three color overlay. Whenever a value other than “00” is placed on the overlay inputs, the corresponding overlay color is displayed. When the overlay inputs contain “00,” the color is specified by the pixel inputs.

When CR15 and CR14 = “1,” the PS inputs are completely ignored. There is no overlay, no bypass switching and the RGB outputs are enabled.

Bypass Color Mode Control (CR17–CR16)

These bits control the mode during bypass switching. There are three different modes: 24-bit Bypass, 16-bit Bypass or 15-bit Bypass Mode.

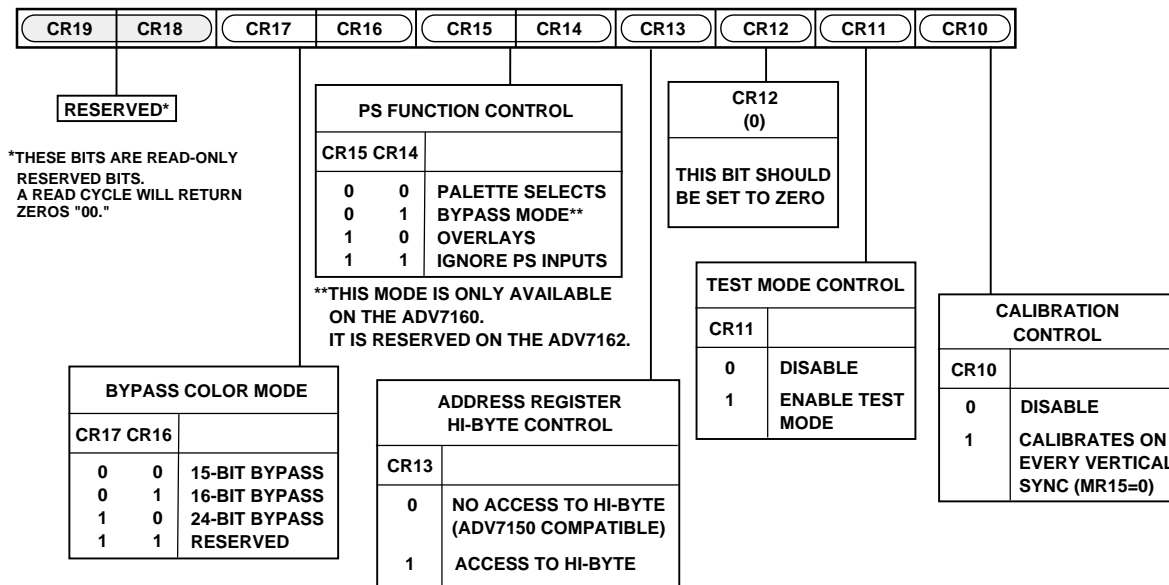

Figure 40. Command Register 1 (CR1) (CR19–CR10)

ADV7160/ADV7162

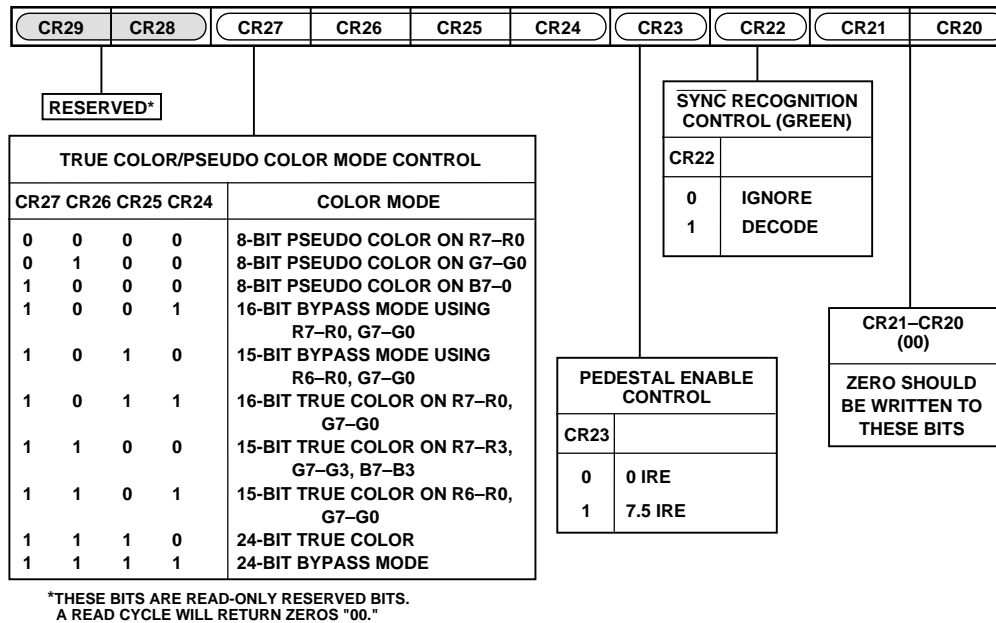

Figure 41. Command Register 2 (CR2) (CR29–CR20)

COMMAND REGISTER 2 (CR2)

(Address Reg (A10–A0) = 006H)

This register contains a number of control bits as shown in the diagram. CR2 is a 10-bit wide register. However for programming purposes, it may be considered as an 8-bit wide register (CR29 and CR28 are both reserved).

Figure 41 shows the various operations under the control of CR2. This register can be read from as well written to. In write mode zero should be written to CR21 and CR20. In read mode, CR29 and CR28 are returned as zeros.

COMMAND REGISTER 2-BIT DESCRIPTION

SYNC Recognition Control on Green (CR22)

This bit specifies whether the video SYNC Input is to be encoded onto the IOG analog output or ignored.

Pedestal Enable Control (CR23)

This bit specifies whether a 0 IRE or a 7.5 IRE blanking pedestal is to be generated on the video outputs.

True-Color/Bypass/Pseudo-Color Mode Control (CR27–CR24)

These 4 bits specify the various color modes. These include a 24-bit true-color and bypass mode, one 16-bit true-color and bypass mode, two 15-bit true-color modes, one 15-bit bypass mode and three 8-bit pseudo color modes.

COMMAND REGISTER 3 (CR3)

(Address Reg (A10–A0) = 007H)

This register contains a number of control bits as shown in the diagram. CR3 is a 10-bit wide register. However for programming purposes, it may be considered as an 8-bit wide register (CR39 and CR38 are both reserved).

Figure 42 shows the various operations under the control of CR3. This register can be read from as well written to. In write mode zero should be written to CR35. In read mode, CR39 and CR38 are returned as zeros.

COMMAND REGISTER 3 BIT DESCRIPTION

PRGCKOUT Frequency Control (CR31–CR30)

These bits specify the output frequency of the PRGCKOUT output. PRGCKOUT is a divided down version of the pixel CLOCK.

BLANK Pipeline Delay Control (CR34–CR32)

These bits specify the additional pipeline delay that can be added to the BLANK function, relative to the overall device pipeline delay (t_{PD}). As the BLANK control normally enters the Video DAC from a shorter pipeline than the video pixel data, this control is useful in de-skewing the pipeline differential.

Pixel Multiplex Control (CR37–CR36)

These bits specify the device's multiplex mode. It therefore also determines the frequency of the LOADOUT signal. LOADOUT is a divided down version of the pixel CLOCK.

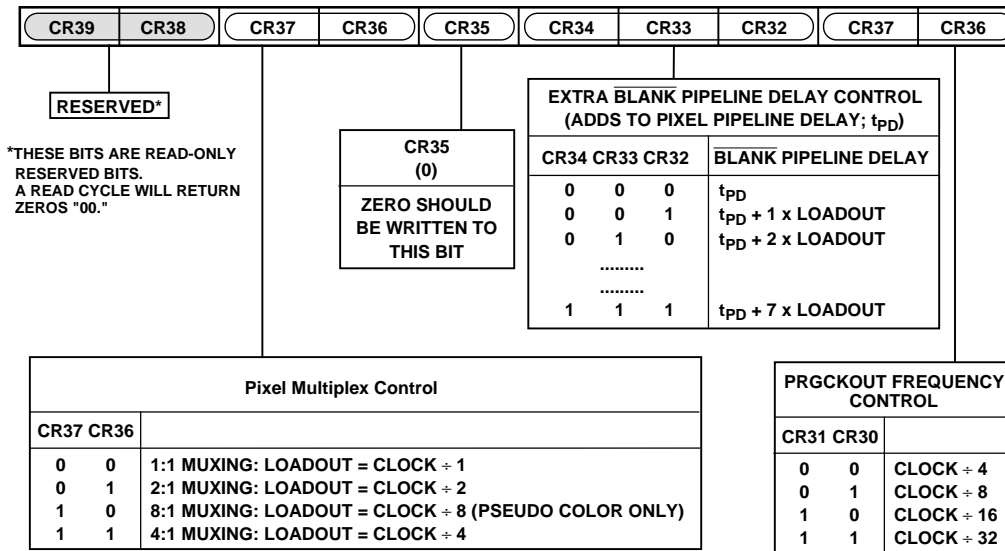

Figure 42. Command Register 3 (CR3) (CR39–CR30)

COMMAND REGISTER 4 (CR4) (ADDRESS REG (A10–A0) = 008H)

This register contains a number of control bits as shown in the diagram. CR4 is a 10-bit wide register. However for programming purposes, it may be considered as an 8-bit wide register (CR49 and CR48 are both reserved).

Figure 43 shows the various operations under the control of CR4. This register can be read from as well written to. In read mode, CR49 and CR48 are both returned as zeros.

COMMAND REGISTER 4-BIT DESCRIPTION HDTV SYNC Enable (CR40)

This bit specifies whether the video $\overline{\text{TRISYNC}}$ Input is to be encoded, enabling the DAC outputs to generate a Tri-Level Sync.

SYNC Recognition Control on Red (CR41)

This bit specifies whether the video SYNC Input is to be encoded onto the IOR analog output or ignored.

SYNC Recognition Control on Blue (CR42)

This bit specifies whether the video SYNC Input is to be encoded onto the IOB analog output or ignored.

Gain Control (CR44–CR43)

These bits specifies the amount of gain on the DAC depending on the standard required. See “DAC and Video Outputs” section for more detail. For gain settings that have no pedestal, the pedestal is automatically disabled independently of CR23.

Signature Clock Control (CR45)

This bit enables or disables the clock to the signature analyzer.

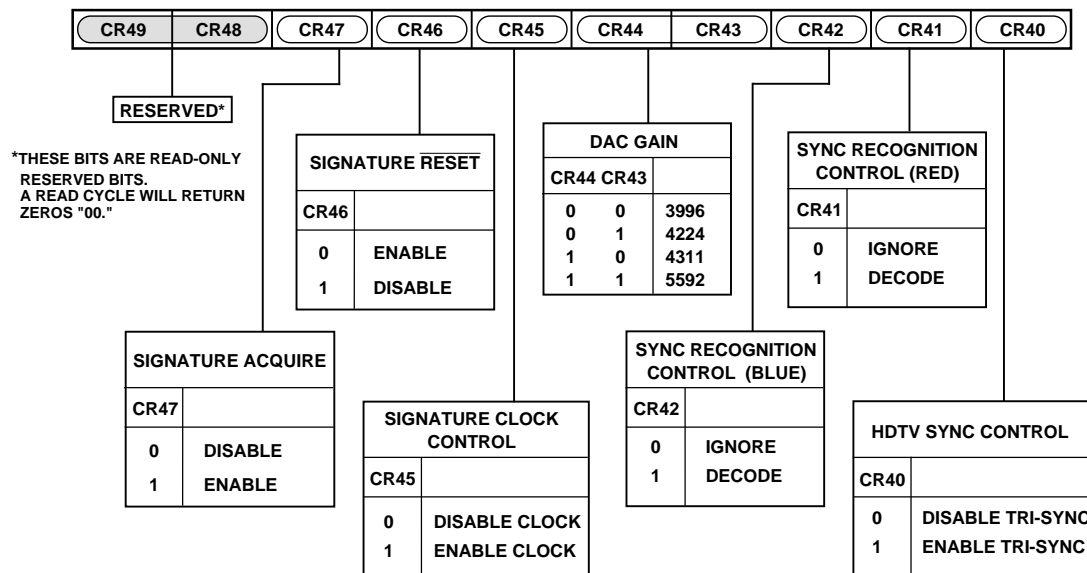

Figure 43. Command Register 4 (CR4) (CR49–CR40)

ADV7160/ADV7162

Signature Reset Control (CR46)

Taking CR46 low then high resets the signature analyzer. This is done to give a known starting point before acquiring a signature.

Signature Acquire Control (CR47)

This bit should be set to Logic "1" for normal operation. See "Test Diagnostic" section for more information.

COMMAND REGISTER 5 (CR5)

(Address Reg (A10-A0) = 00DH)

This register contains one control bit CR56. CR5 is a 10-bit wide register. However for programming purposes, it may be considered as an 8-bit wide register (CR59 and CR58 are both reserved).

This register can be read from as well written to. Control Bit CR56 selects either external clock or internal PLL operation. If the internal PLL is to be used, Logic "1" should be written to CR56. This should be set up immediately after power up. In write mode, zero should be written to CR57 and CR55-CR50. In read mode, CR59 and CR58 are both returned as zeros.

PLL COMMAND REGISTER (PCR)

(Address Reg (A10-A0) = 009H)

This register contains a number of control bits as shown in the diagram. PCR is a 10-bit wide register. However, for programming purposes, it may be considered as an 8-bit wide register (PCR9 and PCR8 are both reserved).

Figure 44 shows the various operations under the control of PCR. This register can be read from as well written to. In write mode zero should be written to PCR3. In read mode PCR9 and PCR8 are returned as zeros.

PLL Control (PCR0)

This bit enables or disables PLL.

RSEL Bit Control (PCR1)

This bit enables or disables RSEL, which together with the contents of the PLL R Register affect the reference divider value of the PLL. Reference Divider = (1 + RSEL) × (R+2).

VSEL Bit Control (PCR2)

This bit enables or disables VSEL, which together with the contents of the PLL V Register and the PLL S value affect the feedback divider value of the PLL.

Feedback Divider = (1 + $\overline{\text{VSEL}}$) × (4(V + 2)+S).

Output Divide Control (PCR5-PCR4)

These bits control the PLL output divider. This post-scaler is used in the generation of lower frequencies.

PLL S Control (PCR7-PCR6)

These bits set up the S value in the PLL transfer function. This extra value provides extra control in setting the feedback divider value of the PLL.

Status Register

(Address Reg (A10-A0) = 00AH)

This register is a read only 10-bit register. However SR9-SR8 are reserved bits, containing zeros and SR7-SR1 are undefined bits and should be masked in software on read back. Therefore, SR0 is the only relevant Bit in the Status Register and contains a Logic "1" if one, or more of the IOR, IOG, and IOB outputs exceed the internal voltage of the SENSE comparator circuit. It can be used to determine the presence of a CRT monitor. With some diagnostic code, the presence of loading on the individual RGB lines can be determined. The reference is generated by a voltage divider from the external voltage reference on the V_{REF} pin. For the proper operation, the following levels should be applied to the comparator by the IOR, IOG and IOB outputs:

DAC Low Voltage ≤ 250 mV
DAC High Voltage ≥ 450 mV

Revision Register

(Address Reg (A10-A0) = 01BH)

This register is a read only register containing the revision of silicon.

PLL R Register

(Address Reg (A10-A0) = 00CH)

This register is a read only 10-bit register. However, R9-R8 are reserved bits, containing zeros. Bit R7 is a read only bit. This bit should be masked in software on readback as its value may be indeterminate. Therefore, the PLL R Register may be treated as a 7-bit wide register. This register, together with the RSEL Bit in the PLL Control Register, controls the reference divider of the on-board PLL.

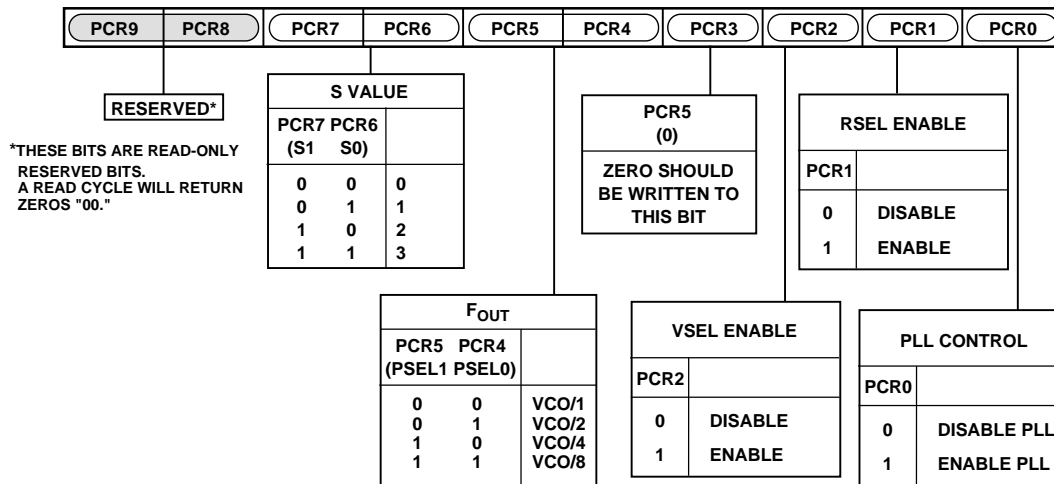

Figure 44. Command Register (PCR) (PCR9-PCR0)

PLL V Register

(Address Reg (A10-A0) = 00FH)

This register is a read only 10-bit register. However V9-V8 are reserved bits, containing zeros. Bit V7 is a read only bit. This bit should be masked in software on readback as its value may be indeterminate. Therefore, the PLL V Register may be treated as a 7-bit wide register. This register, together with the VSEL Bit in the PLL Control Register, controls the feedback divider of the on-board PLL.

64 × 64 Cursor

The ADV7160/ADV7162 has a 64 × 64 cursor generator on board. Several of the control registers control the cursor. These will be described in detail. The Cursor-X and Cursor-Y registers specify the position the cursor is to be placed on the screen. The origin (0, 0) of the cursor is top left. The position of the cursor is taken relative to this point, allowing the Cursor-X and Cursor-Y registers to be programmed with negative numbers and thus allow the cursor to be partially or completely off the screen. The cursor can work as an X-11 or XGA cursor, controlled by Bits CCR0 and CCR1 of the Cursor Control Register.

The screen X and Y coordinates are measured from the rising edge of $\overline{\text{BLANK}}$. The first pixel after the rising edge of $\overline{\text{BLANK}}$ corresponds to the origin (0, 0). The Vertical retrace time is extracted from the composite SYNC and $\overline{\text{BLANK}}$ inputs. The start of Vertical Retrace is recognized by counting a second rising edge on SYNC while $\overline{\text{BLANK}}$ remains low. The next rising edge on $\overline{\text{BLANK}}$ is the start of line 0.

Cursor X-Lo and Cursor X-Hi Register

(Address Reg (A10-A0) = 200H and 201H)

These 8-bit registers together form a 16-bit 2s complement representation of the cursor x-coordinate on the screen. The valid range for the cursor x-coordinate is ±FFFH. The negative number representation allows for part or all of the cursor to be displayed off the left-hand edge of the screen

Cursor Y-Lo and Cursor Y-Hi Register

(Address Reg (A10-A0) = 202H and 203H)

These 8-bit registers together form a 16-bit 2s complement representation of the cursor y-coordinate on the screen. The valid range for the cursor y-coordinate is ±FFFH. The negative number representation allows for part or all of the cursor to be displayed off the top/left of the screen.

When accessing the cursor X and Y registers, the Address Register auto-increments after each access. There are no restrictions on updating the cursor coordinate registers other than they must all be written in the order X-Low, X-Hi, Y-Low, Y-Hi to update the coordinates. Only one cursor is displayed per frame, at the last X and Y coordinates written. Access to these registers is independent of the databus being configured for 8- or 10-bit operation.

Cursor Color 1 and Cursor Color 2 Register

(Address Reg (A10-A0) = 304H and 303H)

Each of these color registers are 30 bits wide, made up of 10 bits for Red, 10 bits for Green and 10 bits for Blue. Access to these registers behaves in the same way as access to the Color Palette with respect to the different combinations of 10/8-bit databus and 10/8-bit DAC resolution.

Cursor Image

(Address Reg (A10-A0) = 400H-7FFH)

This region contains the 64 × 64 × 2-bit Cursor Image. Eight

bits are stored at each address. With two bits per cursor pixel, four horizontally adjacent pixels are stored at each address. As each address location in the Cursor Image is filled, the progression is from left to right until a line is filled and top to bottom until all the lines are filled. The cursor can be displayed on both an interlaced and noninterlaced system, as controlled by CCR3 of the Cursor Control Register. On an interlaced system, only one cursor can be displayed per field. The ODD/EVEN input indicates which field of the frame is being displayed.

Cursor Y Coordinate Even

The Even field starts with line 0 of the cursor image on line Y of the frame. Subsequent even lines of the cursor image are displayed on subsequent lines of the Even field. On the Even field, the frame line counter starts at 0 and increments by 2 at the end of every Even field line. The Odd field starts with line 1 of the cursor image on line Y + 1 of the frame. Subsequent odd lines of the cursor image are displayed on subsequent lines of the Odd field. On the Odd field, the frame line counter starts at 1 and increments by 2 at the end of every Odd field line.

Cursor Y Coordinate Odd

The Even field starts with line 1 of the cursor image on line Y + 1 of the frame. Subsequent even lines of the cursor image are displayed on subsequent lines of the Even field. On the Even field, the frame line counter starts at 1 and increments by 2 at the end of every Even field line. The Odd field starts with line 0 of the cursor image on line Y of the frame. Subsequent odd lines of the cursor image are displayed on subsequent lines of the Odd field. On the Odd field, the frame line counter starts at 0 and increments by 2 at the end of every Odd field line.

Cursor Control Register

(Address Reg (A10-A0) = 204H)

This register contains a number of control bits. CCR is a 10-bit wide register. However for programming purposes, it may be considered as an 8-bit wide register (CCR8 and CCR9 are both reserved). In write mode zero should be written to CCR4 to CCR7. In read mode, CCR8 and CCR9 are all returned as zeros.

Figure 45 shows the various operations under the control of CCR.

**CURSOR CONTROL REGISTER BIT DESCRIPTION
CURSOR MODE CONTROL (CCR1-CCR0)**

These bits specify which type of cursor is being used. Each cursor pixel value controls the color differently in each mode.

Table II.

Bit 1	Bit 0	X-11 Cursor	XGA Cursor
0	0	Transparent	Color 1
0	1	Transparent	Color 2
1	0	Color 1	Transparent
1	1	Color 2	Bit-Wise Complement

Cursor Enable Control (CCR2)

This bit turns the cursor on and off.

Interlace Control (CCR3)

This bit determines whether the cursor is being used in interlaced or noninterlaced mode.

ADV7160/ADV7162

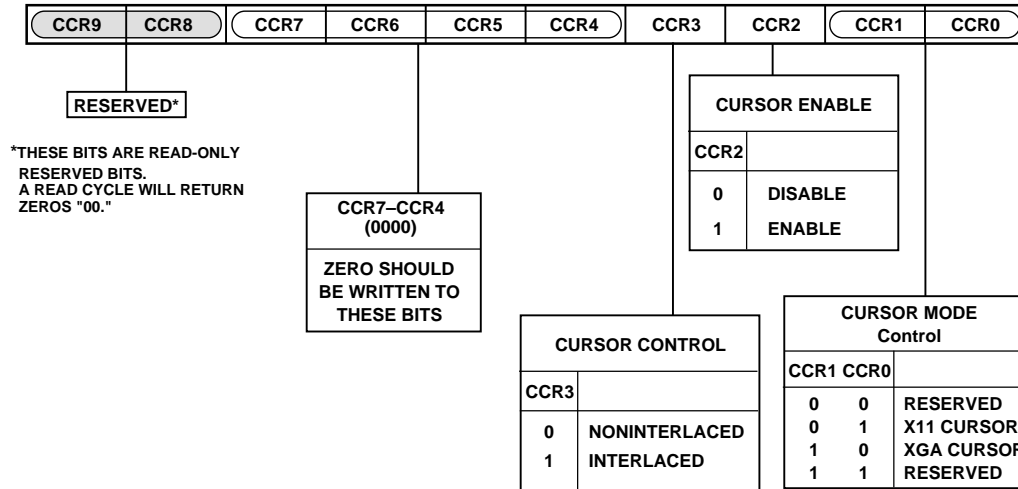

Figure 45. Cursor Control Register (CCR) (CCR9-CCR0)

DIGITAL-TO-ANALOG CONVERTER (DACs) AND VIDEO OUTPUTS

The ADV7160/ADV7162 contains three high speed video DACs. The DAC outputs are represented as the three primary analog color signals IOR (red video), IOG (green video) and IOB (blue video).

DACs and Analog Outputs

The part contains three matched 10-bit digital-to-analog converters. The DACs are designed using an advanced, high speed, segmented architecture. The bit currents corresponding to each digital input are routed to either IOR, IOG, IOB (bit = "1") or GND.

The analog video outputs are high impedance current sources. Each of these three RGB current outputs are specified to directly drive a 37.5 Ω load (doubly terminated 75 Ω).

Reference Input and R_{SET}

An external 1.23 V voltage reference is required to set up the analog outputs of the ADV7160/ADV7162. The reference voltage is connected to the V_{REF} input.

A resistor R_{SET} is connected between the R_{SET} input of the part and ground. For specified performance, R_{SET} has a value of 280 Ω. This corresponds to the generation of RS-343A video levels (with SYNC on IOG and Pedestal = 7.5 IRE) into a doubly terminated 75 Ω load. In this example DAC Gain has a value of 3996 and is set using CR43 and CR44 of Command Register 4. Figure 47 illustrates the resulting video waveform and the Video Output Truth Table illustrates the corresponding control input stimuli. On the ADV7160/ADV7162 SYNC can be encoded on any of the analog signals, however in practice, SYNC is generally encoded on either the IOG output or on all of the video outputs.

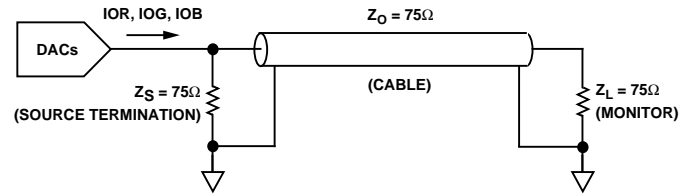

Figure 46. DAC Output Termination (Doubly Terminated 75 Ω Load)

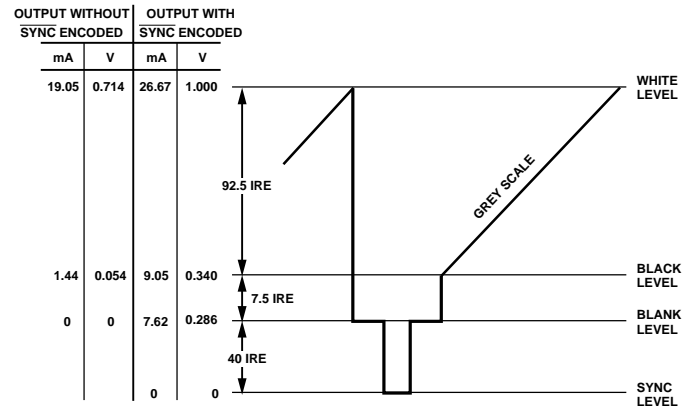

Figure 47. Composite Video Waveform SYNC Decoded; Pedestal = 7.5 IRE; DAC Gain = 3996

Table III. Video Output Truth Table

Description	O/P with Sync Enabled (mA)	O/P with Sync Disabled (mA)	SYNC	BLANK	DAC Input Data
WHITE LEVEL	26.67	19.05	1	1	3FFH
VIDEO	Video + 9.05	Video + 1.44	1	1	Data
VIDEO to BLANK	Video + 1.44	Video + 1.44	0	1	Data
BLACK LEVEL	9.05	1.44	1	1	000H
BLACK to BLANK	1.44	1.44	0	1	000H
BLANK LEVEL	7.62	0	1	0	xxxH
SYNC LEVEL	0	0	0	0	xxxH

Variations on RS-343A

Various other video output configurations can be implemented by the ADV7160/ADV7162, including RS-170. The table shows calculated values of DAC Gain for some of the most common variants on the RS-343A standard. The associated waveforms are shown in the diagrams.

Gain	Video Signal
4224	RS343A, SYNC decoded on output; Pedestal = 0 IRE
4311	RS343A, No SYNC decoded; Pedestal = 0 IRE
5592	RS170, SYNC decoded; Pedestal = 7.5 IRE

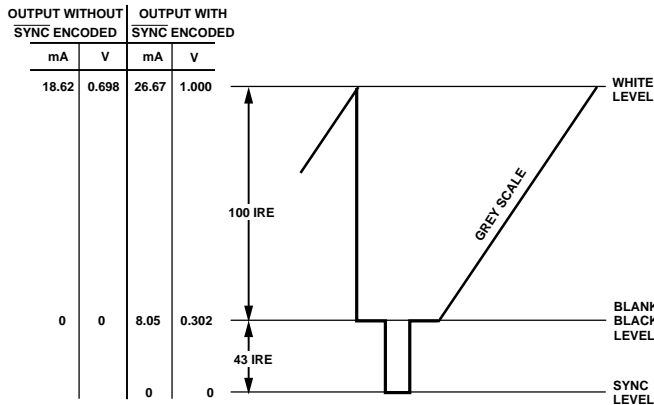

Figure 48. Composite Video Waveform SYNC Decoded; Pedestal = 0 IRE; DAC Gain = 4224

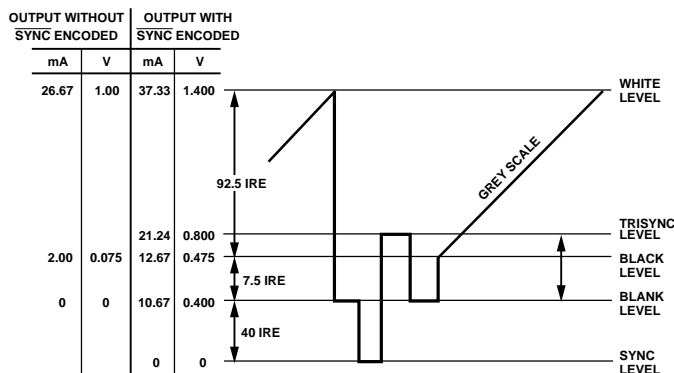

Figure 49. Composite Video Waveform SYNC and TRISYNC decoded; Pedestal = 7.5 IRE; DAC Gain = 5592

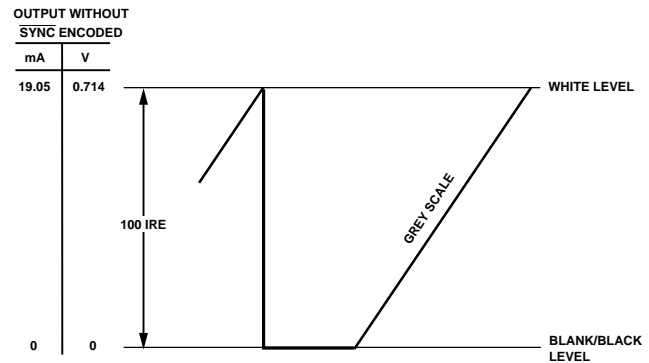

Figure 50. Composite Video Waveform Pedestal = 0 IRE; DAC Gain = 4311

Output Currents

The various output currents are set by V_{REF} , R_{SET} and the DAC gain. By programming the Command Register Bits and choosing the correct DAC Gain value, video waveforms conforming to the common variations on RS-170 and RS-343A, as well as HDTV standards may be generated. The currents generated can be summarized as:

$$I_{OUT} = I_{DAC} + I_{BLANK} + I_{SYNC} + I_{TRISYNC}$$

$$I_{DAC} (mA) = \frac{DAC\ GAIN \times V_{REF}}{R_{SET}}$$

$$I_{BLANK} (mA) = 0.0817 \times I_{DAC}$$

$$I_{SYNC} (mA) = 0.4322 \times I_{DAC}$$

$$I_{TRISYNC} (mA) = 0.4322 \times I_{DAC}$$

ADV7160/ADV7162

APPENDIX 1

BOARD DESIGN AND LAYOUT CONSIDERATIONS

The ADV7160/ADV7162 is a highly integrated circuit containing both precision analog and high speed digital circuitry. It has been designed to minimize interference effects on the integrity of the analog circuitry by the high speed digital circuitry. It is imperative that these same design and layout techniques be applied to the system level design such that high speed, accurate performance is achieved. The “Recommended Analog Circuit Layout” shows the analog interface between the device and monitor.

The layout should be optimized for lowest noise on the ADV7160/ADV7162 power and ground lines by shielding the digital inputs and providing good decoupling. The lead length between groups of V_{AA} and GND pins should be minimized so as to minimize inductive ringing.

Ground Planes

The ground plane should encompass all ADV7160/ADV7162 ground pins, voltage reference circuitry, power supply bypass circuitry for the ADV7160/ADV7162, the analog output traces, and all the digital signal traces leading up to the ADV7160/ADV7162. The ground plane is the graphics board's common ground plane.

Power Planes

The ADV7160/ADV7162 and any associated analog circuitry should have its own power plane, referred to as the analog power plane (V_{AA}). This power plane should be connected to the regular PCB power plane (V_{CC}) at a single point through a ferrite bead. This bead should be located within three inches of the ADV7160/ADV7162.

The PCB power plane should provide power to all digital logic on the PC board, and the analog power plane should provide power to all ADV7160/ADV7162 power pins and voltage reference circuitry.

Plane-to-plane noise coupling can be reduced by ensuring that portions of the regular PCB power and ground planes do not overlay portions of the analog power plane, unless they can be arranged such that the plane-to-plane noise is common mode.

Supply Decoupling

For optimum performance, bypass capacitors should be installed using the shortest leads possible, consistent with reliable

operation, to reduce the lead inductance. Best performance is obtained with 0.1 μ F ceramic capacitor decoupling. Each group of V_{AA} pins on the ADV7160/ADV7162 must have at least one 0.1 μ F decoupling capacitor to GND. These capacitors should be placed as close as possible to the device.

It is important to note that while the ADV7160/ADV7162 contains circuitry to reject power supply noise, this rejection decreases with frequency. If a high frequency switching power supply is used, the designer should pay close attention to reducing power supply noise and consider using a three terminal voltage regulator for supplying power to the analog power plane.

Digital Signal Interconnect

The digital inputs to the ADV7160/ADV7162 should be isolated as much as possible from the analog outputs and other analog circuitry. Also, these input signals should not overlay the analog power plane.

Due to the high clock rates involved, long clock lines to the ADV7160/ADV7162 should be avoided to reduce noise pickup. Any active termination resistors for the digital inputs should be connected to the regular PCB power plane (V_{CC}), and not the analog power plane.

Analog Signal Interconnect

The ADV7160/ADV7162 should be located as close as possible to the output connectors to minimize noise pickup and reflections due to impedance mismatch.

The video output signals should overlay the ground plane, and not the analog power plane, to maximize the high frequency power supply rejection.

Digital Inputs, especially Pixel Data Inputs and clocking signals (CLOCK, LOADOUT, LOADIN, etc.) should never overlay any of the analog signal circuitry and should be kept as far away as possible.

For best performance, the analog outputs (IOR, IOG, IOB) should each have a 75 Ω load resistor connected to GND. These resistors should be placed as close as possible to the ADV7160/ADV7162 so as to minimize reflections.

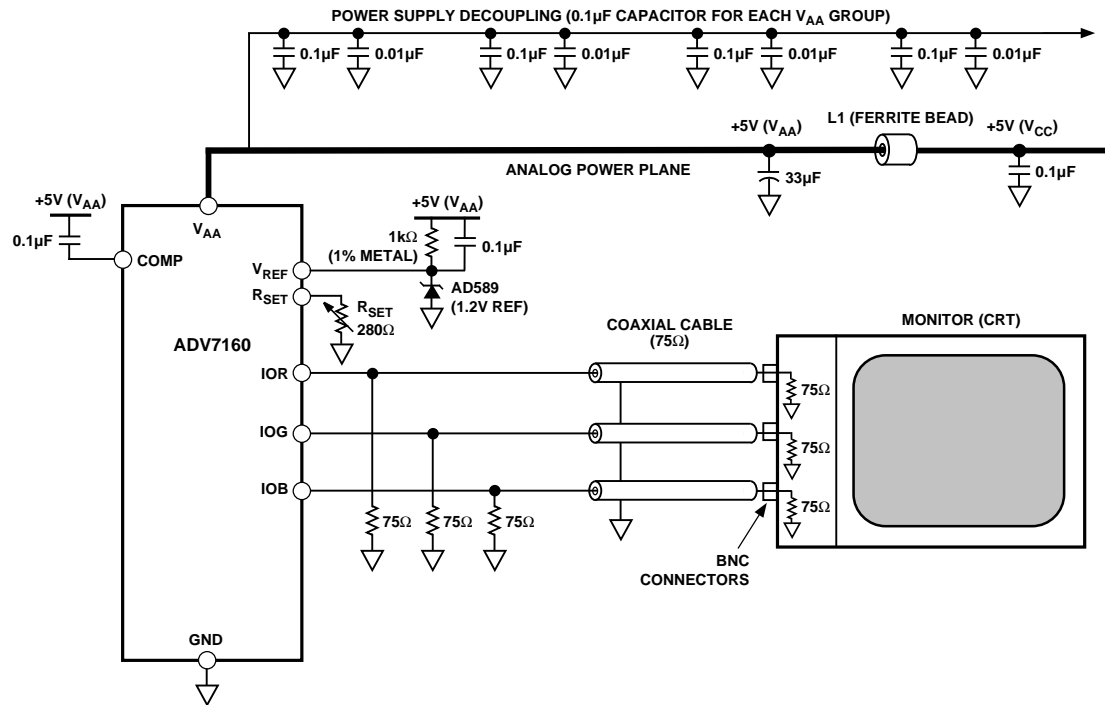

- NOTES:
1. ALL RESISTERS ARE 1% METAL FILM
 2. 0.1µF AND 0.01µF CAPACITORS ARE CERAMIC
 3. ADDITIONAL DIGITAL CIRCUITRY OMITTED FOR CLARITY

Recommended Analog Circuit Layout

ADV7160/ADV7162

APPENDIX 2 TYPICAL FRAME BUFFER INTERFACE

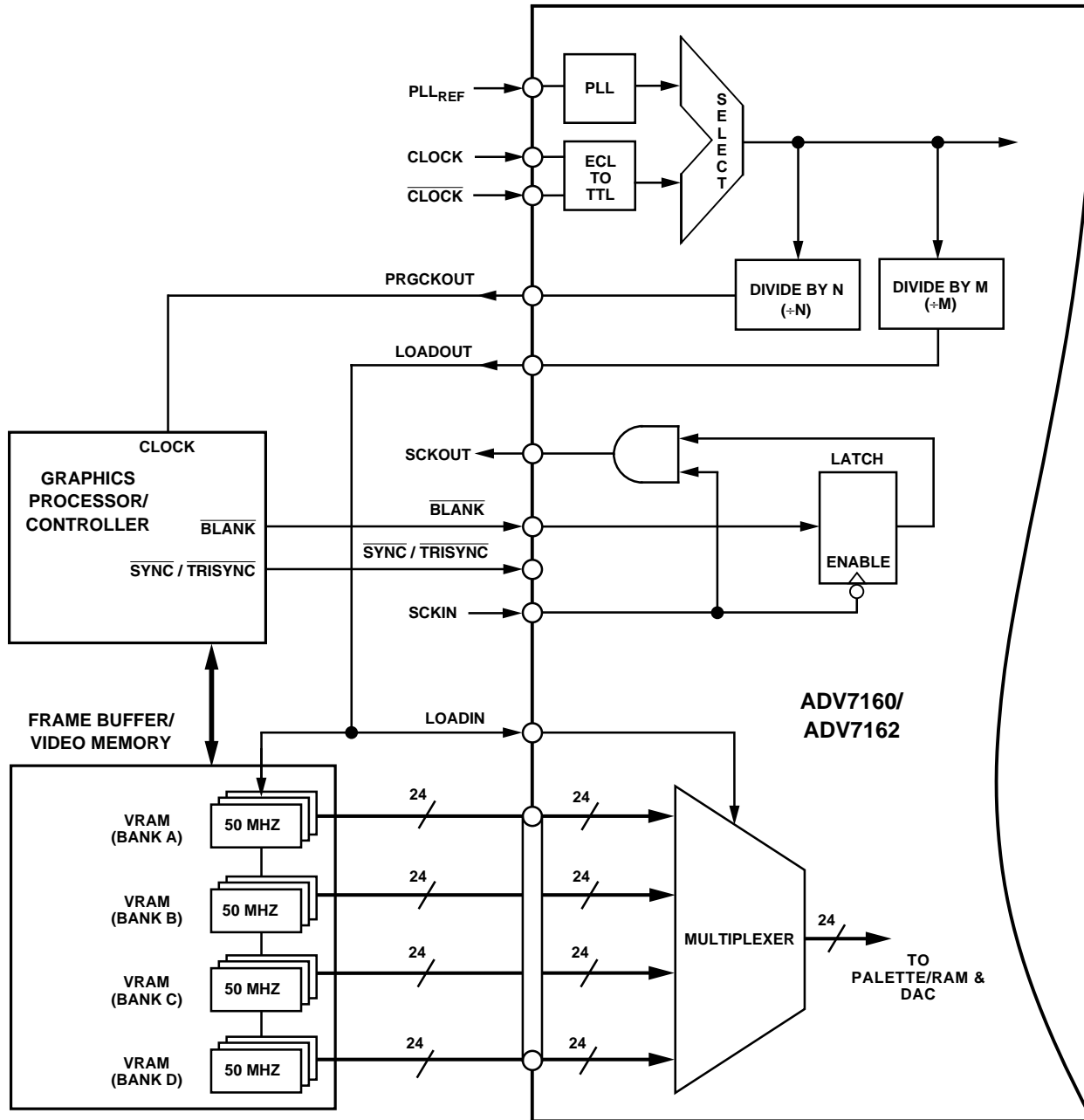

APPENDIX 3

10-BIT DACs AND GAMMA CORRECTION

10-Bit DACs

10-Bit RAM-DAC resolution allows for nonlinear video correction, in particular Gamma Correction. The ADV7160/ADV7162 allows for an increase in color resolution from 24-bit to 30-bit effective color without the necessity of a 30-bit deep frame buffer. In true-color mode, for example, the part effectively operates as a 24-bit to 30-bit color look-up table.

Up to now we have assumed that there exists a linear relationship between the actual RGB values input to a monitor and the intensity produced on the screen. This, however, is not the case. Half scale digital input (1000 0000) might correspond to only 20% output intensity on the CRT (Cathode Ray Tube). The intensity (I_{CRT}) produced on a CRT by an input value I_{IN} is given by:

$$I_{CRT} = (I_{IN})^c$$

where c ranges from 2.0 to 2.8.

If the individual values of c for red, green and blue are known, then so called "Gamma Correction" can be applied to each of the three video input signals (I_{IN}); therefore:

$$I_{IN(\text{corrected})} = k(I_{IN})^{1/c}$$

Traditionally, there has been a trade-off between implementing a nonlinear graphics function, such as gamma correction, and color dynamic range. The ADV7160/ADV7162 overcomes this by increasing the individual color resolution of each of the red, green and blue primary colors from 8 bits per color channel to 10 bits per channel (24 bits to 30 bits).

The table highlights the loss of resolution when 8-bit data is gamma-corrected to a value of 2.7 and quantized in a traditional 8-bit system. Note that there is no change in the 8-bit quantized data for linear changes in the input data over much of the transfer function. On the other hand, when quantized to 10 bits via the 10-bit RAMs and 10-bit DACs of the ADV7160/ADV7162, all changes on the input 8-bit data are reflected in corresponding changes in the 10-bit data.

The graph shows a typical gamma curve corresponding to a gamma value of 2.7. This is programmed to the red, green and blue RAMs of the color look-up table instead of the more traditional linear function. Different curves corresponding to any particular gamma value can be independently programmed to each of the red, green and blue RAMs.

Other applications of the 10-bit RAM-DAC include closed-loop monitor color calibration.

GAMMA CORRECTION 8 Bits vs. 10 Bits

8-Bit Data	Gamma Corrected (2.7)	Quantized to 8 Bits	Quantized to 10 Bits
240	0.977797	250	1001
241	0.979304	250	1002
242	0.980807	251	1004
243	0.982306	251	1005
244	0.983801	251	1007
245	0.985292	252	1008
246	0.986780	252	1010
247	0.988264	252	1011
248	0.989744	253	1013
249	0.991220	253	1015
250	0.992693	254	1016
251	0.994161	254	1018
252	0.995626	254	1019
253	0.997088	255	1021
254	0.998546	255	1022
255	1.000000	255	1023

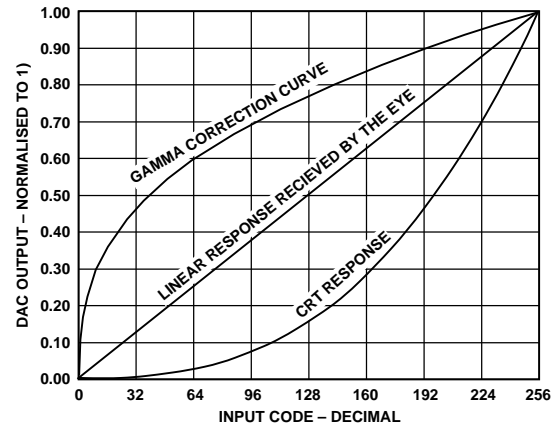

Gamma Correction Curve (Gamma Value = 2.7)

ADV7160/ADV7162

APPENDIX 4

INITIALIZATION AND PROGRAMMING

ADV7160/ADV7162 INITIALIZATION

After power has been supplied, the ADV7160/ADV7162 must be initialized. The Mode Register and Control Registers must then be set up. The values written to the various registers will be determined by the desired operating mode of the part, i.e., True-Color/Pseudo-Color, 4:1 Muxing/2:1 Muxing, PLL on/off, Bypass Mode on/off etc. . . .

The following section gives a recommended initialization of the ADV7160/ADV7162 and an example of the ADV7162 operating in a specific mode.

ADV7160/ADV7162 Initialization	C1	C0	R/W	Comment
Write (xx000xx1)* to Mode Register (MR1)	1	1	0	Resets ADV7160/62
Write (xx000xx0)* to Mode Register (MR1)	1	1	0	
Write (xx000xx1)* to Mode Register (MR1)	1	1	0	
Write 05H to Address Register (A7–A0)	0	0	0	Address Reg points to Command Register 1 (CR1)
Write (xxxx100x)* to Command Register 1 (CR1)	0	0	0	Address Reg points to CR1 for high byte access
Write 06H to Address Register (A7–A0)	0	0	0	
Write 00H to Address Register (A10–A8)	0	0	0	Address Reg points to Command Register 2 (CR2)
Write (xxxxxx00)* to Command Reg 2 (CR2)	1	0	0	Setup CR2 as required
Write 07H to Address Register (A7–A0)	0	0	0	
Write 00H to Address Register (A10–A8)	0	0	0	Address Reg points to Command Register 3 (CR3)
Write (xx0xxxxx)* to Command Reg 3 (CR3)	1	0	0	Setup CR3 as required
Write 08H to Address Register (A7–A0)	0	0	0	
Write 00H to Address Register (A10–A8)	0	0	0	Address Reg points to Command Register 4 (CR4)
Write (xxxxxxx)* to Command Reg 4 (CR4)	1	0	0	Setup CR4 as required
Write 0DH to Address Register (A7–A0)	0	0	0	
Write 00H to Address Register (A10–A8)	0	0	0	Address Reg points to Command Register 5 (CR5)
Write (0x000000)* to Command Reg 5 (CR5)	1	0	0	Setup CR 5 as required
Write 04H to Address Register (A7–A0)	0	0	0	
Write 00H to Address Register (A10–A8)	0	0	0	Address Reg points to Pixel Mask Register
Write (xxxxxxx)* to Pixel Mask Register	1	0	0	Set up Pixel Mask as required
Write 04H to Address Register (A7–A0)	0	0	0	Necessary only if CCR to be used
Write 02H to Address Register (A10–A8)	0	0	0	Address Reg points to Cursor Control Register (CCR)
Write (xxxxxxx)* to Cursor Control Register	1	0	0	Set up CCR as required
Write 0FH to Address Register (A7–A0)	0	0	0	Necessary only if PLL to be used
Write 00H to Address Register (A10–A8)	0	0	0	Address Reg points to PLL V Register
Write (xxxxxxx)* to PLL V Register	1	0	0	Set up V as required
Write 0CH to Address Register (A7–A0)	0	0	0	Necessary only if PLL to be used
Write 00H to Address Register (A10–A8)	0	0	0	Address Reg points to PLL R Register
Write (xxxx0xxx)* to PLL R Register	1	0	0	Set up R as required
Write 09H to Address Register (A7–A0)	0	0	0	Necessary only if PLL to be used
Write 00H to Address Register (A10–A8)	0	0	0	Address Reg points to PLL Command Register (PCR)
Write (xxxxxxx)* to PLLCommand Register	1	0	0	Set up PCR as required
Write (xx0xxxxx)* to Mode Register (MR1)	1	1	0	Necessary only if manual claibration is required
Write (xx1xxxxx)* to Mode Register (MR1)	1	1	0	Toggles MR15
Write (xx0xxxxx)* to Mode Register (MR1)	1	1	0	

*x represents either a 0 or 1 value that the bit should be set to, depending on the desired operating mode of the ADV7160/ADV7162.

Example

Color Mode: 24-Bit Gamma Corrected True Color (30-Bits) through Color Palette
 Multiplexing: 2:1, Databus: 10-Bit, RAM-DAC Resolution: 10-Bit,
 SYNC: on Green, Pedestal: 0 IRE, Calibration: Every Vertical Sync, Internal PLL: 220 MHz (Reference = 15 MHz)

Register Initialization	C1	C0	R/W	Comment
Write 07H to Mode Register (MR1)	1	1	0	Resets ADV7162*
Write 06H to Mode Register (MR1)	1	1	0	10-Bit Data Bus, 10-Bit DAC Resolution
Write 07H to Mode Register (MR1)	1	1	0	
Write 05H to Address Register (A7-A0)	0	0	0	Address Reg points to Command Register 1 (CR1)
Write 09H to Command Register 1 (CR1)	0	0	0	High byte access, Calibrate every Vertical Sync
Write 06H to Address Register (A7-A0)	0	0	0	
Write 00H to Address Register (A10-A8)	0	0	0	Address Reg points to Command Register 2 (CR2)
Write E4H to Command Reg 2 (CR2)	1	0	0	24-Bit True Color, 0 IRE, Sync on Green
Write 07H to Address Register (A7-A0)	0	0	0	
Write 00H to Address Register (A10-A8)	0	0	0	Address Reg points to Command Register 3 (CR3)
Write 40H to Command Reg 3 (CR3)	1	0	0	2:1 Muxing, PRGCKOUT = CLOCK ÷ 4
Write 08H to Address Register (A7-A0)	0	0	0	
Write 00H to Address Register (A10-A8)	0	0	0	Address Reg points to Command Register 4 (CR4)
Write 00H to Command Reg 4 (CR4)	1	0	0	DAC GAIN = 3996
Write 0DH to Address Register (A7-A0)	0	0	0	
Write 00H to Address Register (A10-A8)	0	0	0	Address Reg points to Command Register 5 (CR5)
Write 40H to Command Reg 5 (CR5)	1	0	0	Internal PLL to be used
Write 04H to Address Register (A7-A0)	0	0	0	
Write 00H to Address Register (A10-A8)	0	0	0	Address Reg points to Pixel Mask Register
Write FFH to Pixel Mask Register	1	0	0	Set up Pixel Mask
Write 0FH to Address Register (A7-A0)	0	0	0	
Write 00H to Address Register (A10-A8)	0	0	0	Address Reg points to PLL V Register
Write 09H to PLL V Register	1	0	0	Set up V value
Write 0CH to Address Register (A7-A0)	0	0	0	
Write 00H to Address Register (A10-A8)	0	0	0	Address Reg points to PLL R Register
Write 01H to PLL R Register	1	0	0	Set up R value
Write 09H to Address Register (A7-A0)	0	0	0	
Write 00H to Address Register (A10-A8)	0	0	0	Address Reg points to PLL Command Register (PCR)
Write 06H to PLL Command Register	1	0	0	Set up PCR as required
Color Palette RAM Initialization	C1	C0	R/W	Comment
Write 00H to Address Register (A7-A0)	0	0	0	
Write 00H to Address Register (A10-A8)	0	0	0	Points to Color Palette RAM
Write 00H (red data) to RAM location (00H)	0	1	0	(Initializes Palette RAM
Write 00H (green data) to RAM location (00H)	0	1	0	(to a Linear Ramp**
Write 00H (blue data) to RAM location (00H)	0	1	0	(
Write 01H (red data) to RAM location (01H)	0	1	0	(
Write 01H (green data) to RAM location (01H)	0	1	0	(
Write 01H (blue data) to RAM location (01H)	0	1	0	(
	.	.	.	(
	.	.	.	(
Write FFH (red data) to RAM location (FFH)	0	1	0	(
Write FFH (green data) to RAM location (FFH)	0	1	0	(
Write FFH (blue data) to RAM location (FFH)	0	1	0	(RAM Initialization Complete

*These command lines reset the ADV7162. The pipelines for each of the Red, Green & Blue pixel inputs are synchronously reset to the Multiplexer's "A" input. Mode Register bit MR10 is written by a "1" followed by "0" followed by "1."

**This sequence of instructions would, of course, normally be coded using some form of loop instruction.

APPENDIX 5 SIGNATURE ANALYZER

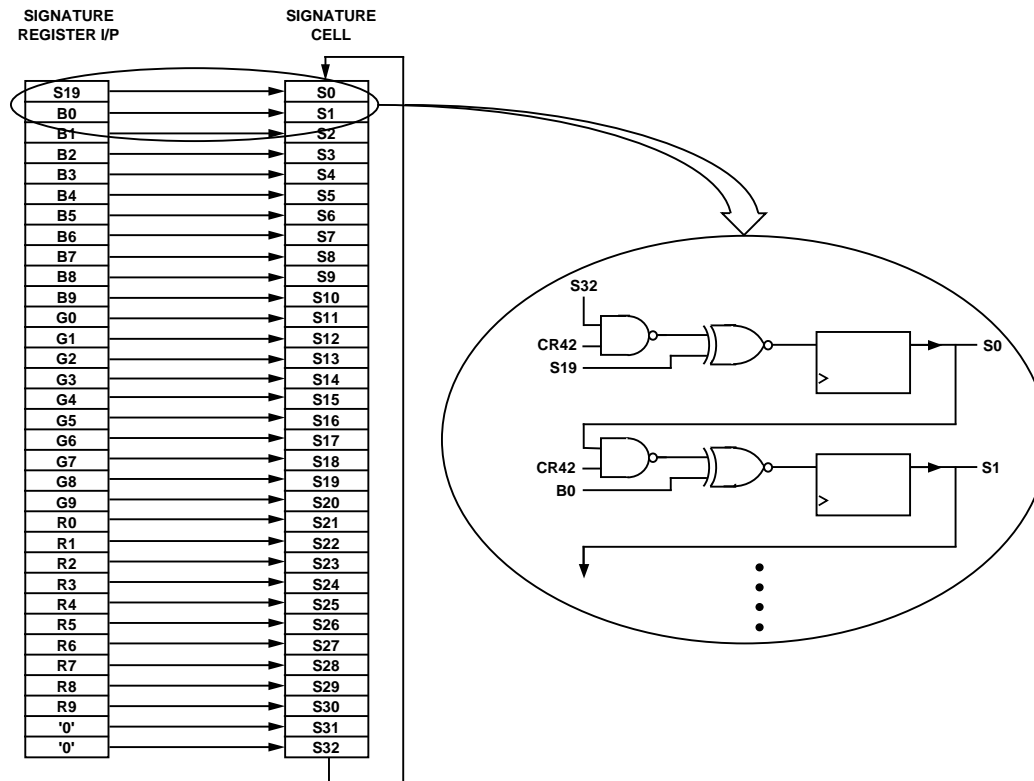

Signature Register

The ADV7160/ADV7162 contains onboard circuitry that enables both device and system level test diagnostics. The ADV7160/ADV7162 has a signature analyzer in the pixel datapath, just before the DAC decoders. The signature analyzer consists of a 33-bit linear feedback shift register. The 30-bit pixel value is fed as a parallel input into the analyzer. The signature analyzer only accumulates a signature during active display time when BLANK is high. Bit CR45 to CR47 of Command Register 4 control the signature analyzer. When CR45 of Command Register 4 is set to Logic “1,” the clock to the signature analyzer is enabled. Toggling CR46 low and then high resets the signature analyzer. This is done to give a known starting point before acquiring a signature. CR47 of Command Register 4 controls the feedback inputs to the analyzer. When CR47 of Command Register 4 is a Logic “0,” the feedback is disabled and on each clock cycle, the 30-bit pixel value is latched directly into the analyzer. To acquire a signature as the analyzer is clocked, CR47 of Command Register 4 is set to Logic “1.” To acquire a signature the following procedure must be followed:

1. CR45 and CR47 of Command Register 4 are set to Logic “1” during vertical retrace and CR46 of Command Register 4 is toggled to reset the analyzer.
2. A signature is acquired during the following active screen.
3. CR45 of Command Register 4 is set to Logic “0” during the following vertical retrace and the acquired signature is read. At least 20 clock cycles should be allowed for the final pixels of the frame to travel down the pipeline of the ADV7160/ADV7162 before the signature clock is disabled.

The signature analyzer is read from control registers 010H to 013H. These are read only 10-bit registers. The access to these registers depends whether the part is in 8-bit or 10-bit data bus mode and operates in the same way as accessing the color palette.

Address Register (A10-A0)	CONTROL		CONTENTS												
	REGISTERS														
0013H	Signature Misc Register		0	0	0	0	0	0	0	0	0	0	S32	S31	S0
0012H	Signature Blue Register		S10	S9	S8	S7	S6	S5	S4	S3	S2	S1			
0011H	Signature Green Register		S20	S19	S18	S17	S16	S15	S14	S13	S12	S11			
0010H	Signature Red Register		S30	S29	S28	S27	S26	S25	S24	S23	S22	S21			

APPENDIX 6

JTAG TEST PORT (IEEE1149.1)

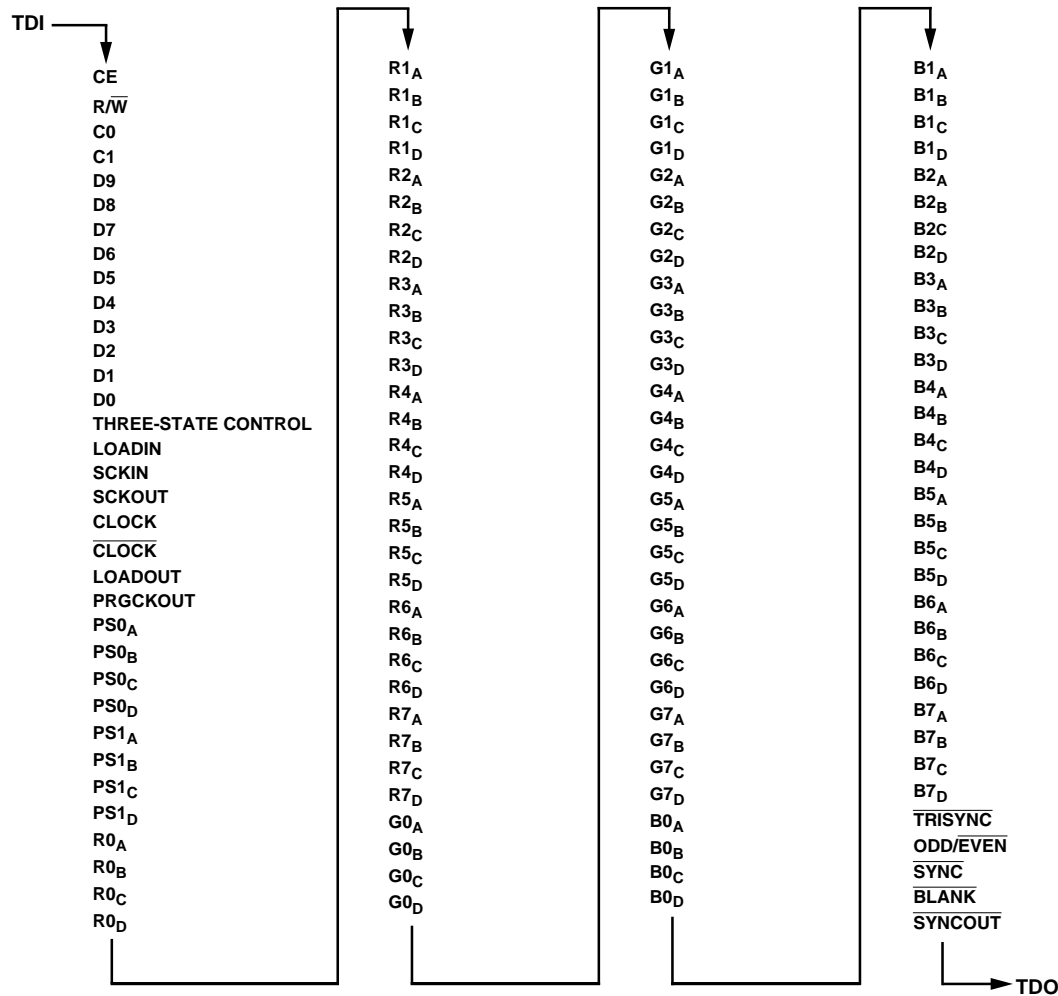

JTAG Boundary Scan Chain

JTAG Test Port

JTAG Test Port is a 4-pin interface consisting of:

- TCK: Test Clock
- TMS: Test Mode Select
- TDI: Test Data Input
- TDO: Test Data Output

To put the ADV7160/ADV7162 into the required mode, the Instruction Register must be loaded.

INSTRUCTION	INSTRUCTION REGISTER CODE
EXTTEST	000
SAMPLE/PRELOAD	001
IDCODE	010
PRIVATE 1	011
BYPASS	100
BYPASS	101
BYPASS	110
BYPASS	111

The ADV7160 implementation has the mandatory instructions: Bypass, Sample/Preload and Exttest, and the optional instruction: IDCode. There is also one private instruction: Private1.

The Private1 instruction is for internal use in production test only.

The IDCode is a 32-bit number which can be scanned out through TDO. Its contents are defined below:

	VERSION (4 BITS)	PART NUMBER (16 BITS)	MANUFACTURER ID (11 BITS)	LSB
ADV7160	1H	2776H	0E5H	1H
ADV7162	1H	2779H	0E5H	1H

The Boundary Scan Chain is a fundamental feature of the JTAG Test Port. It allows all the digital input and output pins on the part to be connected into a shift register between the TDI and TDO pins. The digital pins can be sampled, or controlled over the JTAG port to carry out testing. There is no boundary scan cell on the PLL_{REF} pin. The Three-State Control cell controls the three-state status of the microport databus. There are 131 cells in total on the Boundary Scan Chain.

ADV7160/ADV7162

APPENDIX 7

THERMAL AND ENVIRONMENTAL CONSIDERATIONS

The ADV7160/ADV7162 is a very highly integrated monolithic silicon device. This high level of integration, in such a small package, inevitably leads to consideration of thermal and environmental conditions which the ADV7160/ADV7162 must operate in. Reliability of the device is enhanced by keeping it as cool as possible. In order to avoid destructive damage to the device, the absolute maximum junction temperature of 150°C must never be exceeded. Certain applications, depending on ambient temperature and pixel data rates may require forced air cooling or external heatsinks. The following data is intended as a guide in evaluating the operating conditions of a particular application so that optimum device and system performance is achieved.

It should be noted that information on package characteristics published herein may not be the most up to date at the time of reading this. Advances in package compounds and manufacture will inevitably lead to improvements in the thermal data. Please contact your local sales office for the most up-to-date information.

Power Dissipation

The diagrams show graphs of power dissipation in watts versus pixel clock frequency for the ADV7160 and ADV7162. When using the ADV7162 in Bypass Mode, the Pixel Mask Register should be programmed to 00H to reduce power further.

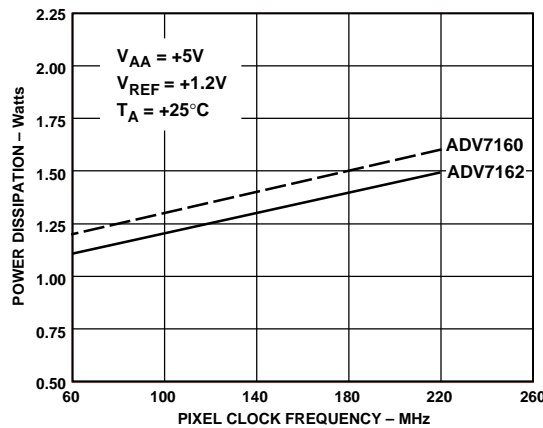

Note:
The "Worst Case On-Screen Pattern" corresponds to full-scale transition on each pixel value for every CLOCK edge (00H, FFH, 00H, ...).
The "Typical On-Screen Pattern" corresponds to linear changes in the pixel input (i.e., a Black to White Ramp).
In general, color images tend to approximate this characteristic.

Typical Power Dissipation vs. Pixel Rate

Package Characteristics

The tables of thermal characteristics show typical information for the ADV7160 (160-Lead Plastic Power QFP) and ADV7162 (160-Lead Plastic QFP) using various values of Airflow.

Junction-to-Case (θ_{JC}) Thermal Resistance for this particular part is:

$$\theta_{JC} (\text{ADV7160}) = 0.4^\circ\text{C/W}$$

$$\theta_{JC} (\text{ADV7162}) = 6.7^\circ\text{C/W}$$

(Note: θ_{JC} is independent of airflow.)

Heatsinks

The maximum silicon junction temperature should be limited to 100°C. Temperatures greater than this will reduce long-term device reliability. To ensure that the silicon junction temperature stays within prescribed limits, the addition of an external heatsink may be necessary. Heatsinks will reduce θ_{JA} as shown in the Thermal Characteristics vs. Airflow table.

Table A. Thermal Characteristics vs. Airflow-ADV7160*

Air Velocity (Linear Feet/min)	0 (Still Air)	50	100	200
θ_{JA} °C/W				
No Heatsink	25.5	23	21	19
EG&G D10100-28 Heatsink	23	20	18	16
Thermalloy 2290 Heatsink	19	17	15	12

*These figures do not include thermal conduction through the package leads into the PCB. Thermal conduction through the leads can provide up to 10°C/W reduction in θ_{JA} .

Table B. Thermal Characteristics vs. Airflow-ADV7162*

Air Velocity (Linear Feet/min)	0 (Still Air)	50	100	200
θ_{JA} °C/W				
No Heatsink	37	32	30	28
EG&G D10850-40 Heatsink	28	24	22	19
EG&G D10851-36 Heatsink	32	24	19	14

*These figures do not include thermal conduction through the package leads into the PCB. Thermal conduction through the leads can provide up to 5°C/W reduction in θ_{JA} .

Thermal Model

The junction temperature of the device in a specific application is given by:

$$T_J = T_A + P_D (\theta_{JC} + \theta_{CA}) \quad (1)$$

or

$$T_J = T_A + P_D (\theta_{JA}) \quad (2)$$

where:

T_J = Junction Temperature of Silicon (°C)

T_A = Ambient Temperature (°C)

P_D = Power Dissipation (W)

θ_{JC} = Junction to Case Thermal Resistance (°C/W)

θ_{CA} = Case to Ambient Thermal Resistance (°C/W)

θ_{JA} = Junction to Ambient Thermal Resistance (°C/W)

Package Enhancements for ADV7160

The standard PQFP package has been enhanced to a PowerQuad2 package. This supports an improved thermal performance compared to standard PQFP. In this case, the die is attached to a heat slug so that the power that is dissipated can be conducted to the external surface of the package. This provides a highly efficient path for the transfer of heat to the package surface. The package configuration also provides an efficient thermal path from the ADV7160 to the Printed Circuit Board.

PAGE INDEX

Topic	Page
FEATURES	1
GENERAL DESCRIPTION	1 & 15
ADV7160/ADV7162 BLOCK DIAGRAM	1
ADV7160/ADV7162 SPECIFICATIONS	2
ADV7160/ADV7162 TIMING CHARACTERISTICS	3-5
TIMING WAVEFORMS	5-11
ORDERING GUIDE	11
ABSOLUTE MAXIMUM RATINGS	11
PIN CONFIGURATIONS	12
PIN FUNCTION DESCRIPTION	13-14
CIRCUIT DETAILS AND OPERATION	15
PIXEL PORT	15-16
CLOCK CONTROL CIRCUIT	16-17
CLOCK CONTROL SIGNALS	17-18
PLL	18
COLOR VIDEO MODES	19
PIXEL PORT MAPPING	19-21
MULTIPLEXING	21-22
MPU PORT	22
INTERNAL REGISTER CONFIGURATION	23
COLOR PALETTE ACCESS	24-25
ON-CHIP REGISTERS	26
Address Register	26
Mode Register	26
ID Register	27
Pixel Mask Register	27
Command Register 1	27
Command Register 2	28
Command Register 3	28-29
Command Register 4	29-30
Command Register 5	30
PLL Command Register	30
PLL R Register	30
PLL V Register	31
Status Register	30
Revision Register	30
CURSOR DESCRIPTION	31-32
Cursor X-Low and X-High Register	31
Cursor Y-Low & Y-High Register	31
Cursor Image	31
Cursor Y Coordinate Even	31
Cursor Y Coordinate Odd	31
Cursor Control Register	31-32
DACS & VIDEO OUTPUTS	32-33
APPENDIX 1	
Board Design and Layout Considerations	34-35
APPENDIX 2	
Typical Frame Buffer Interface	36
APPENDIX 3	
10-Bit DACs and Gamma Correction	37
APPENDIX 4	
Initialization and Programming	38-39
APPENDIX 5	
Signature Analyzer	40
APPENDIX 6	
JTAG Test Port	41
APPENDIX 7	
Thermal and Environmental Considerations	42
INDEX	43
OUTLINE DIMENSIONS	44

FIGURE INDEX

Figure	Title
1	Load Circuit for Data-Bus Access & Relinquish Times
2	JTAG Port Timing
3	LOADOUT vs. Pixel Clock Input
4	LOADIN vs. Pixel Input Data
5	Pixel Input to Analog Output Pipeline with Minimum LOADOUT to LOADIN Delay (8:1 Mode)
6	Pixel Input to Analog Output Pipeline with Maximum LOADOUT to LOADIN Delay (8:1 Mode)
7	Pixel Input to Analog Output Pipeline with Minimum LOADOUT to LOADIN Delay (4:1 Mode)
8	Pixel Input to Analog Output Pipeline with Maximum LOADOUT to LOADIN Delay (4:1 Mode)
9	Pixel Input to Analog Output Pipeline with Minimum LOADOUT to LOADIN Delay (2:1 Mode)
10	Pixel Input to Analog Output Pipeline with Maximum LOADOUT to LOADIN Delay (2:1 Mode)
11	Pixel Clock Input vs. Programmable Clock Output
12	SCKIN vs. SCKOUT
13	Analog Output Response vs. Pixel Clock
14	MPU Timing
15	Multiplexed Color Inputs
16	Clock Control Circuit
17	LOADOUT vs. Pixel Clock
18	SCKOUT Generation Circuit
19	Interface Using SCKIN and SCKOUT
20	PLL Block Diagram
21	PLL Transfer Function
22	PLL Jitter
23	24-Bit to 30-Bit True Color Configuration
24	15-Bit to 24-Bit True Color Configuration
25	8-Bit to 30-Bit Pseudo Color Configuration
26	16-Bit True Color Mapping Using R7-R0 and G7-G0
27	15-Bit True Color Mapping Using R7-R3, G7-G3 and B7-B3
28	15-Bit True Color Mapping Using R6-R0 and G7-G0
29	16-Bit True Color (Bypass) Using R7-R0 and G7-G0
30	15-Bit True Color (Bypass) Using R6-R0 and G7-G0
31	Direct Interfacing of Video Memory
32	8-Bit Pseudo Color in 8:1 Multiplexing Mode
33	MPU Port and Register Configuration
34	Internal Register Configuration and Address Decoding
35	8-Bit Databus Using 10-Bit DACs
36	8-Bit Databus Using 8-Bit DACs
37	10-Bit Databus Using 10-Bit DACs
38	10-Bit Databus Using 8-Bit DACs
39	Mode Register 1
40	Command Register 1
41	Command Register 2
42	Command Register 3
43	Command Register 4
44	PLL Command Register
45	Cursor Control Register
46	DAC Output Termination
47	Composite Video Waveform, SYNC decoded; Pedestal = 7.5 IRE; DAC Gain = 3996
48	Composite Video Waveform, SYNC decoded; Pedestal = 0 IRE; DAC Gain = 4224
49	Composite Video Waveform, SYNC & TRISYNC decoded; Pedestal = 7.5 IRE; DAC Gain = 5592
50	Composite Video Waveform, Pedestal = 0 IRE; DAC Gain = 4311

ADV7160/ADV7162

OUTLINE DIMENSIONS

Dimensions shown in inches and (mm).

S-160 160-Lead Plastic Quad Flatpack

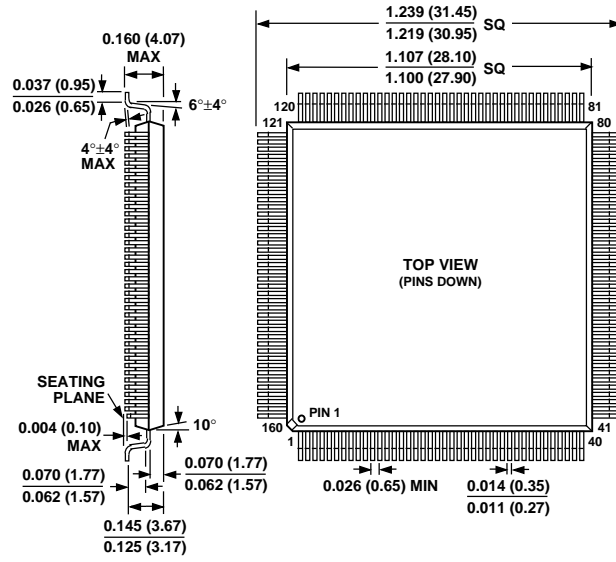

C2013-6-4/95

PRINTED IN U.S.A.



LittleDiode supplies new, hard to find or obsolete electronic components and semiconductors all over the world.

With over two million different components listed you are sure to find the part you need.

Feel free to visit us today at our online store:

LittleDiode.com

Looking forward to providing you with the best possible service.