



# AFE1105

## HDSL/MDSL ANALOG FRONT END

### FEATURES

- COMPLETE ANALOG INTERFACE
- T1, E1, AND MDSL OPERATION
- CLOCK SCALEABLE SPEED
- SINGLE CHIP SOLUTION
- +5V ONLY (5V OR 3.3V DIGITAL)
- 250mW POWER DISSIPATION
- 48-PIN SSOP
- -40°C TO +85°C OPERATION

### DESCRIPTION

Burr-Brown's Analog Front End greatly reduces the size and cost of an HDSL or MDSL system by providing all of the active analog circuitry needed to connect the Metalink MtH1210B HDSL digital signal processor to an external compromise hybrid and a 1:2.3 HDSL line transformer. All internal filter responses as well as the pulse former output scale with clock frequency—allowing the AFE1105 to operate over a range of bit rates from 196kbps to 1.168Mbps.

Functionally, this unit is separated into a transmit and a receive section. The transmit section generates, filters, and buffers outgoing 2B1Q data. The receive section filters and digitizes the symbol data received on the telephone line and passes it to the MtH1210B. The HDSL Analog Interface is a monolithic device fabricated on 0.6 $\mu$ CMOS. It operates on a single +5V supply. It is housed in a 48-pin SSOP package.

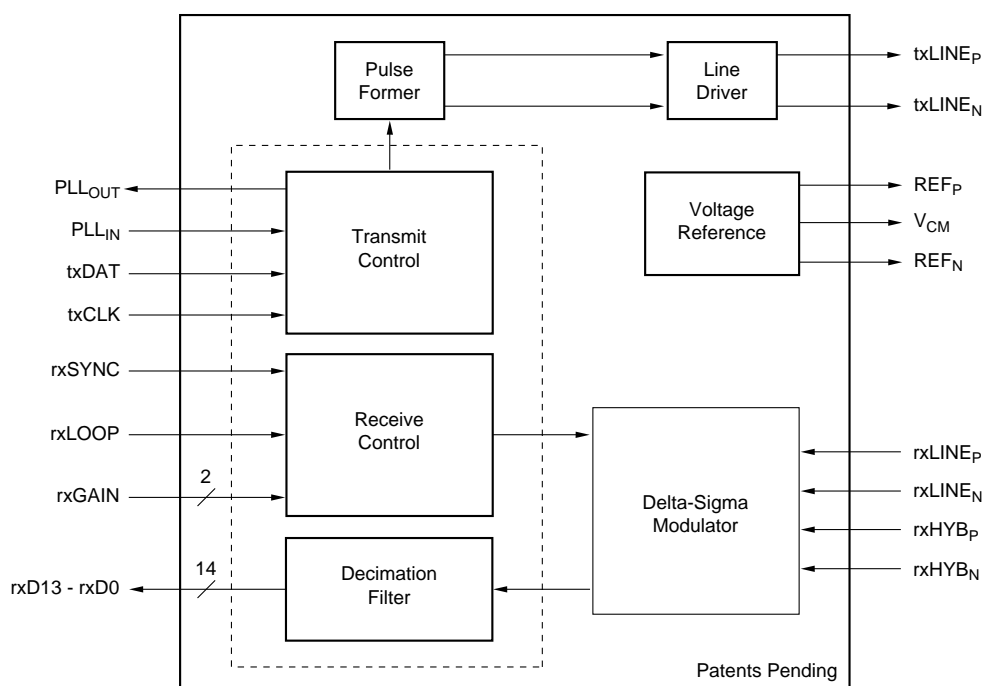

# SPECIFICATIONS

Typical at 25°C, AV<sub>DD</sub> = +5V, DV<sub>DD</sub> = +3.3V, f<sub>ix</sub> = 584kHz (E1 rate), unless otherwise specified.

PARAMETER	COMMENTS	AFE1105E			UNITS
		MIN	TYP	MAX	
<b>RECEIVE CHANNEL</b> Number of Inputs Input Voltage Range Common-Mode Voltage Input Impedance Input Capacitance Input Gain Matching Resolution Programmable Gain Settling Time for Gain Change  Gain + Offset Error Output Data Coding Output Data Rate, rxSYNC <sup>(3)</sup>	Differential Balanced Differential <sup>(1)</sup> 1.5V CMV Recommended All Inputs  Line Input vs Hybrid Input  Four Gains: 0dB, 3.25dB, 6dB, and 9dB  Tested at Each Gain Range	2     14 0   98	 ±3.0 +1.5  See Typical Performance Curves 10 ±2   6  5 Two's Complement	          584 <sup>(4)</sup>	V V  pF % Bits dB Symbol Periods %FSR <sup>(2)</sup>  kHz
<b>TRANSMIT CHANNEL</b> Transmit Symbol Rate, f <sub>ix</sub> T1 Transmit -3dB Point T1 Rate Power Spectral Density <sup>(5)</sup> E1 Transmit -3dB Point E1 Rate Power Spectral Density <sup>(5)</sup> Transmit Power <sup>(5)</sup> Pulse Output Common-Mode Voltage, V <sub>CM</sub> Output Resistance <sup>(6)</sup>	Bellcore TA-NWT-3017 Compliant  ETSI RTR/TM-03036 Compliant  DC to 1MHz	98         98	 196 See Typical Performance Curves 292 See Typical Performance Curves 13 See Typical Performance Curves  AV <sub>DD</sub> /2 1	584 <sup>(4)</sup>         14	kHz kHz  kHz dBm  V Ω
<b>TRANSCEIVER PERFORMANCE</b> Uncancelled Echo <sup>(7)</sup>	rxGAIN = 0dB, Loopback Enabled rxGAIN = 0dB, Loopback Disabled rxGAIN = 3.25dB, Loopback Disabled rxGAIN = 6dB, Loopback Disabled rxGAIN = 9dB, Loopback Disabled			-67 -67 -69 -71 -73	dB dB dB dB dB
<b>DIGITAL INTERFACE<sup>(6)</sup></b> Logic Levels V <sub>IH</sub> V <sub>IL</sub> V <sub>OH</sub> V <sub>OL</sub> Transmit/Receive Channel Interface t <sub>ix1</sub> t <sub>ix2</sub>	        I <sub>IH</sub>   < 10μA  I <sub>IL</sub>   < 10μA I <sub>OH</sub> = -20μA I <sub>OL</sub> = 20μA  txCLK Period txCLK Pulse Width	DV <sub>DD</sub> -1 -0.3 DV <sub>DD</sub> -0.5  1.7 t <sub>ix1</sub> /16	          10.2 15t <sub>ix1</sub> /16	          10.2 15t <sub>ix1</sub> /16	V V V V  μs ns
<b>POWER</b> Analog Power Supply Voltage Analog Power Supply Voltage Digital Power Supply Voltage Digital Power Supply Voltage Power Dissipation <sup>(4, 8)</sup> Power Dissipation <sup>(4, 8)</sup> PSRR	Specification Operating Range Specification Operating Range DV <sub>DD</sub> = 3.3V, 1:2 Line Transformer DV <sub>DD</sub> = 5V, 1:2 Line Transformer	4.75  3.15  60	5  3.3  250 300	5.25  5.25	V V V V mW mW dB
<b>TEMPERATURE RANGE</b> Operating <sup>(6)</sup>		-40		+85	°C

NOTES: (1) With a balanced differential signal, the positive input is 180° out of phase with the negative input, therefore the actual voltage swing about the common mode voltage on each pin is ±1.5V to achieve a differential input range of ±3.0V or 6Vp-p. (2) FSR is Full-Scale Range. (3) The output data is available at twice the symbol rate with interpolated values. (4) This specification does not apply to the AFE1105EA. (5) With a pseudo-random equiprobable sequence of HDSL pulses; 13.5dBm applied to the transformer (27dBm output from txLINE<sub>P</sub> and txLINE<sub>N</sub>). (6) Guaranteed by design and characterization. (7) Uncancelled Echo is a measure of the total analog errors in the transmitter and receiver sections including the effect of non-linearity and noise. See the Discussion of Specifications section of this data sheet for more information. (8) Power dissipation includes only the power dissipated within the component and does not include power dissipated in the external loads. The AFE1105 is tested with a 1:2 line transformer, but will typically be used with a 1:2.3 line transformer, this will slightly increase power dissipation.

## PIN DESCRIPTIONS

PIN #	TYPE	NAME	DESCRIPTION
1	Ground	PGND	Analog Ground for PLL
2	Power	PV <sub>DD</sub>	Analog Supply (+5V) for PLL
3	Input	txCLK	Symbol Clock (XMTLE from Mth1210B) (392kHz for T1, 584kHz for E1)
4	Ground	DGND	Digital Ground
5	Input	txDAT	XMTDA from Mth1210B
6	Output	rxD0	ADC Output Bit-0
7	Output	rxD1	ADC Output Bit-1
8	Output	rxD2	ADC Output Bit-2 (RCVD0 from Mth1210B)
9	Output	rxD3	ADC Output Bit-3 (RCVD1 from Mth1210B)
10	Output	rxD4	ADC Output Bit-4 (RCVD2 from Mth1210B)
11	Output	rxD5	ADC Output Bit-5 (RCVD3 from Mth1210B)
12	Ground	DGND	Digital Ground
13	Power	DV <sub>DD</sub>	Digital Supply (+3.3V to +5V)
14	Output	rxD6	ADC Output Bit-6 (RCVD4 from Mth1210B)
15	Output	rxD7	ADC Output Bit-7 (RCVD5 from Mth1210B)
16	Output	rxD8	ADC Output Bit-8 (RCVD6 from Mth1210B)
17	Output	rxD9	ADC Output Bit-9 (RCVD7 from Mth1210B)
18	Output	rxD10	ADC Output Bit-10 (RCVD8 from Mth1210B)
19	Output	rxD11	ADC Output Bit-11 (RCVD9 from Mth1210B)
20	Output	rxD12	ADC Output Bit-12 (RCVD10 from Mth1210B)
21	Output	rxD13	ADC Output Bit-13 (RCVD11 from Mth1210B)
22	Power	DV <sub>DD</sub>	Digital Supply (+3.3V to +5V)
23	Input	rxSYNC	ADC Sync Signal (RCVCK from Mth1210B) (392kHz for T1, 584kHz for E1)
24	Input	rxGAIN0	Receive Gain Control Bit-0
25	Input	rxGAIN1	Receive Gain Control Bit-1 (RCVG0 from Mth1210B)
26	Input	rxLOOP	Loopback Control Signal (loopback is enabled by positive signal)
27	Power	AV <sub>DD</sub>	Analog Supply (+5V)
28	Input	rxHYB <sub>N</sub>	Negative Input from Hybrid Network
29	Input	rxHYB <sub>P</sub>	Positive Input from Hybrid Network
30	Input	rxLINE <sub>N</sub>	Negative Line Input
31	Input	rxLINE <sub>P</sub>	Positive Line Input
32	Ground	AGND	Analog Ground
33	Ground	AGND	Analog Ground
34	Output	REF <sub>P</sub>	Positive Reference Output, Nominally 3.5V
35	Output	V <sub>CM</sub>	Common-Mode Voltage (buffered), Nominally 2.5V
36	Output	REF <sub>N</sub>	Negative Reference Output, Nominally 1.5V
37	Power	AV <sub>DD</sub>	Analog Supply (+5V)
38	Ground	AGND	Analog Ground
39	Output	txLINE <sub>N</sub>	Transmit Line Output Negative
40	Power	AV <sub>DD</sub>	Analog Supply (+5V)
41	Output	txLINE <sub>P</sub>	Transmit Line Output Positive
42	Ground	AGND	Analog Ground
43	NC	NC	Connection to Ground Recommended
44	NC	NC	Connection to Ground Recommended
45	NC	NC	Connection to Ground Recommended
46	NC	NC	Connection to Ground Recommended
47	Output	PLL <sub>OUT</sub>	PLL Filter Output
48	Input	PLL <sub>IN</sub>	PLL Filter Input

The information provided herein is believed to be reliable; however, BURR-BROWN assumes no responsibility for inaccuracies or omissions. BURR-BROWN assumes no responsibility for the use of this information, and all use of such information shall be entirely at the user's own risk. Prices and specifications are subject to change without notice. No patent rights or licenses to any of the circuits described herein are implied or granted to any third party. BURR-BROWN does not authorize or warrant any BURR-BROWN product for use in life support devices and/or systems.

## PIN CONFIGURATION

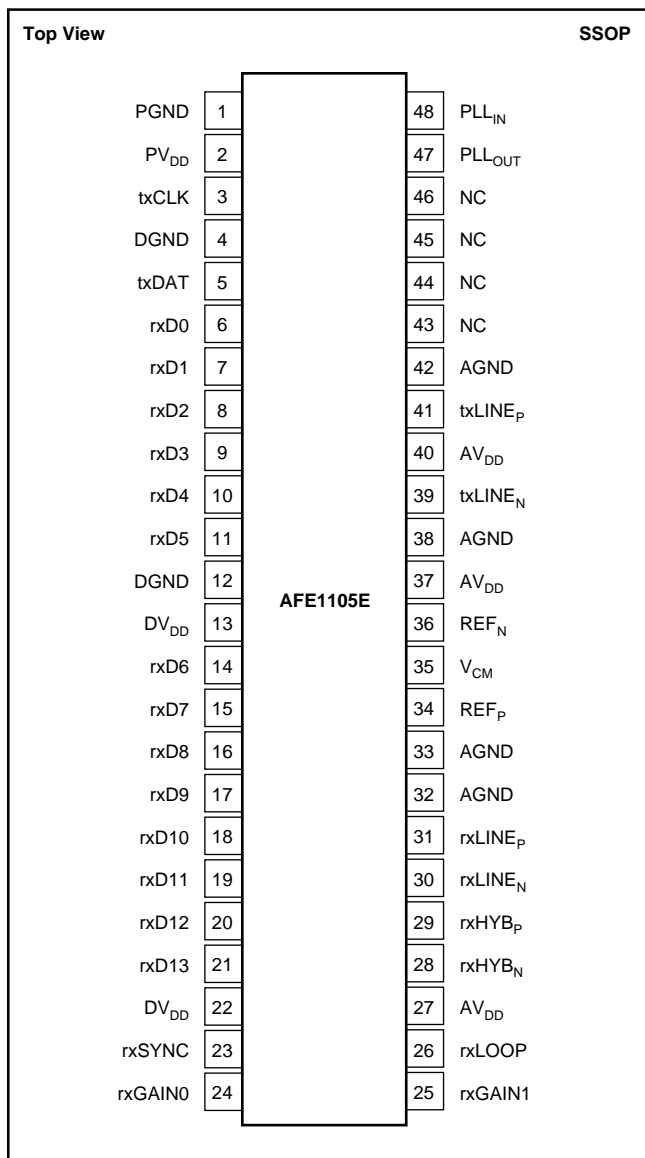

## ABSOLUTE MAXIMUM RATINGS

Analog Inputs: Current	±100mA, Momentary ±10mA, Continuous
Voltage	AGND -0.3V to AV <sub>DD</sub> +0.3V
Analog Outputs Short Circuit to Ground (+25°C)	Continuous
AV <sub>DD</sub> to AGND	-0.3V to 6V
PV <sub>DD</sub> to PGND	-0.3V to 6V
DV <sub>DD</sub> to DGND	-0.3V to 6V
PLL <sub>IN</sub> or PLL <sub>OUT</sub> to PGND	-0.3V to PV <sub>DD</sub> +0.3V
Digital Input Voltage to DGND	-0.3V to DV <sub>DD</sub> +0.3V
Digital Output Voltage to DGND	-0.3V to DV <sub>DD</sub> +0.3V
AGND, DGND, PGND Differential Voltage	0.3V
Junction Temperature (T <sub>J</sub> )	+150°C
Storage Temperature Range	-40°C to +125°C
Lead Temperature (soldering, 3s)	+260°C
Power Dissipation	700mW



## ELECTROSTATIC DISCHARGE SENSITIVITY

This integrated circuit can be damaged by ESD. Burr-Brown recommends that all integrated circuits be handled with appropriate precautions. Failure to observe proper handling and installation procedures can cause damage.

ESD damage can range from subtle performance degradation to complete device failure. Precision integrated circuits may be more susceptible to damage because very small parametric changes could cause the device not to meet its published specifications.

## PACKAGE/ORDERING INFORMATION

PRODUCT	MAXIMUM BIT RATE	PACKAGE	PACKAGE DRAWING NUMBER <sup>(1)</sup>	TEMPERATURE RANGE
AFE1105E	1.168Mbps	48-Pin Plastic SSOP	333	-40°C to +85°C
AFE1105EA	512kbps	48-Pin Plastic SSOP	333	-40°C to +85°C

NOTE: (1) For detailed drawing and dimension table, please see end of data sheet, or Appendix C of Burr-Brown IC Data Book.

# TYPICAL PERFORMANCE CURVES

## At Output of Pulse Transformer

Typical at 25°C, AV<sub>DD</sub> = +5V, DV<sub>DD</sub> = +3.3V, unless otherwise specified.

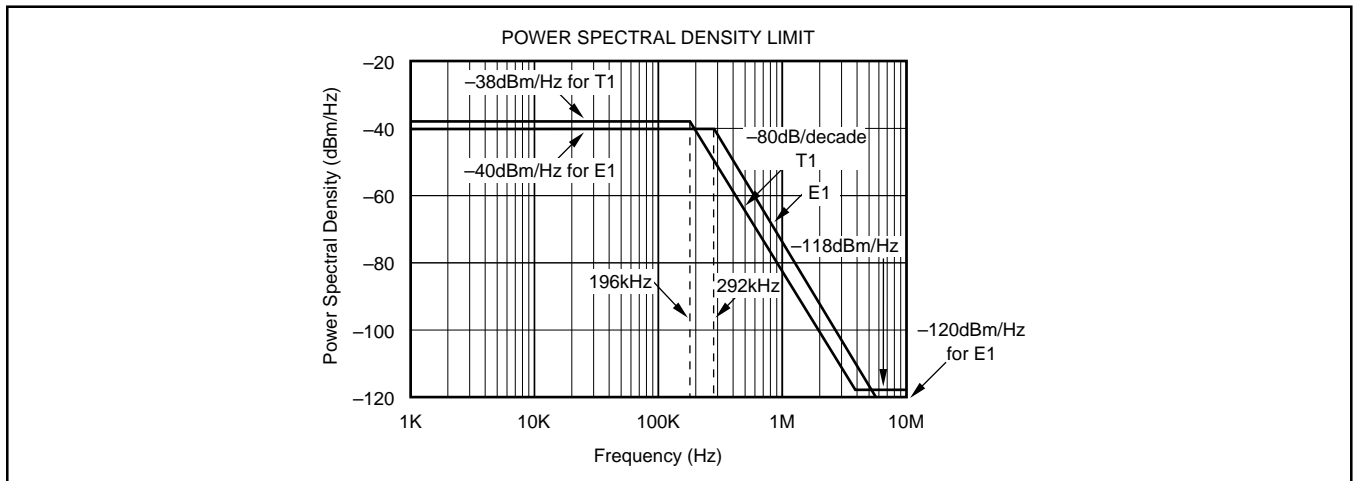

CURVE 1. Upper Bound of Power Spectral Density Measured at the Transformer Output.

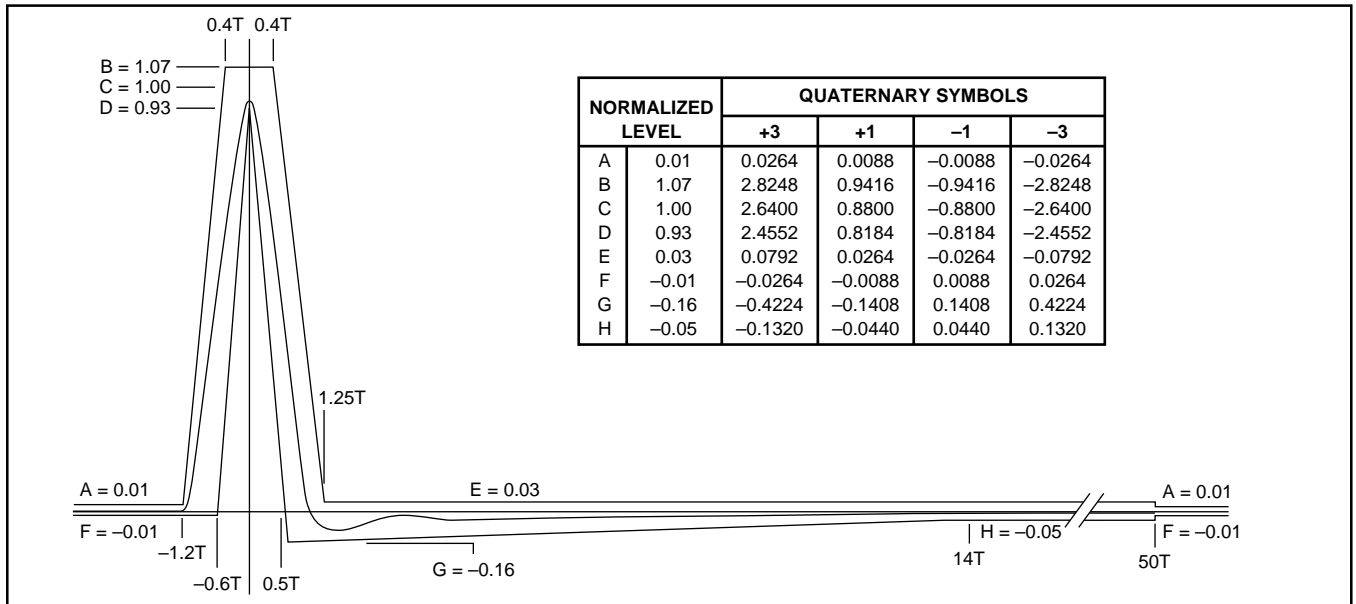

CURVE 2. Transmitted Pulse Template and Actual Performance as Measured at the Transformer Output.

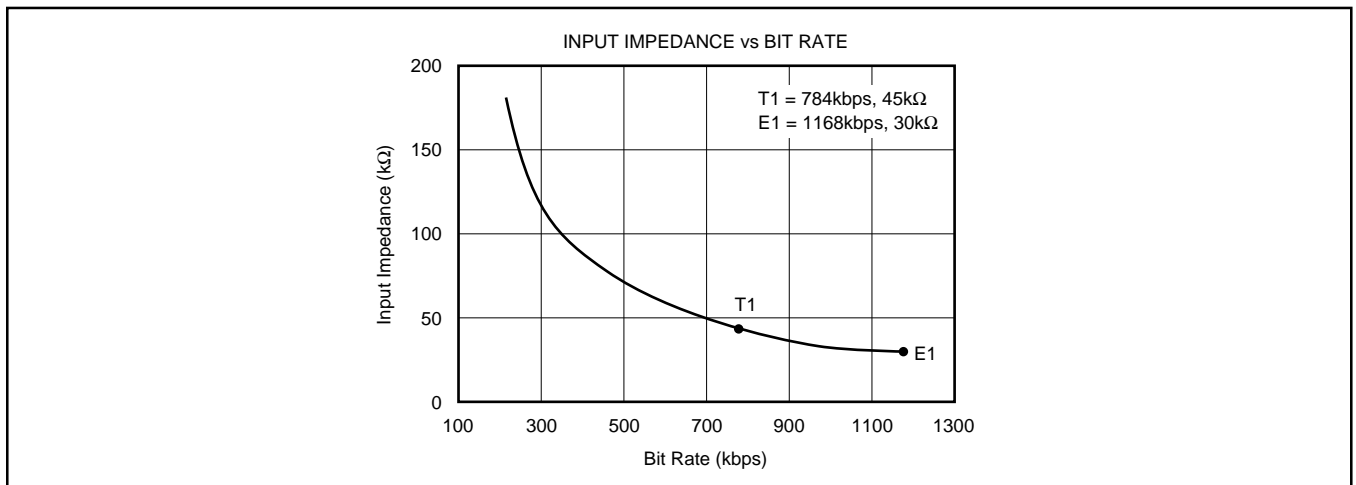

CURVE 3. Input Impedance of rxLINE and rxHYB.

# THEORY OF OPERATION

The transmit channel consists of a switched-capacitor pulse forming network followed by a differential line driver. The pulse forming network receives symbol data from the XMTDA output of the Mth1210B and generates a 2B1Q output waveform. The output meets the pulse mask and power spectral density requirements defined in European Telecommunications Standards Institute document RTR/TM-03036 for E1 mode and in sections 6.2.1 and 6.2.2.1 of Bellcore technical advisory TA-NWT-001210 for T1 mode. The differential line driver uses a composite output stage combining class B operation (for high efficiency driving large signals) with class AB operation (to minimize cross-over distortion).

The receive channel is designed around a fourth-order delta sigma A/D converter. It includes a difference amplifier designed to be used with an external compromise hybrid for first order analog crosstalk reduction. A programmable gain amplifier with gains of 0dB to +9dB is also included. The delta sigma modulator operating at a 24X oversampling ratio produces 14 bits of resolution at output rates up to 584kHz. The basic functionality of the AFE1105 is illustrated in Figure 1 shown below.

The receive channel operates by summing the two differential inputs, one from the line (rxLINE) and the other from the compromise hybrid (rxHYB). The connection of these two inputs so that the hybrid signal is subtracted from the line signal is described in the paragraph titled "Echo Cancellation in the AFE". The equivalent gain for each input in the difference amp is 1. The resulting signal then passes to a programmable gain amplifier which can be set for gains of 0dB through 9dB. The ADC converts the signal to a 14-bit digital word, rxD13-rxD0.

## rxLOOP INPUT

rxLOOP is the loopback control signal. When enabled, the rxLINE<sub>P</sub> and rxLINE<sub>N</sub> inputs are disconnected from the AFE. The rxHYB<sub>P</sub> and rxHYB<sub>N</sub> inputs remain connected. Loopback is enabled by applying a positive signal (Logic 1) to rxLOOP.

## ECHO CANCELLATION IN THE AFE

The rxHYB input is designed to be subtracted from the rxLINE input for first order echo cancellation. To accomplish this, note that the rxLINE input is connected to the same polarity signal at the transformer (positive to positive and negative to negative) while the rxHYB input is connected to opposite polarity through the compromise hybrid (negative to positive and positive to negative) as shown in Figure 2.

## RECEIVE DATA CODING

The data from the receive channel A/D converter is coded in two's complement code.

ANALOG INPUT	OUTPUT CODE (rxD13 - rxD0)
Positive Full Scale	01111111111111
Mid Scale	00000000000000
Negative Full Scale	10000000000000

## RECEIVE CHANNEL PROGRAMMABLE GAIN AMPLIFIER

The gain of the amplifier at the input of the Receive Channel is set by two gain control pins, rxGAIN1 and rxGAIN0. The resulting gain between 0dB and +9dB is shown below.

rxGAIN1	rxGAIN0	GAIN
0	0	0dB
0	1	3.25dB
1	0	6dB
1	1	9dB

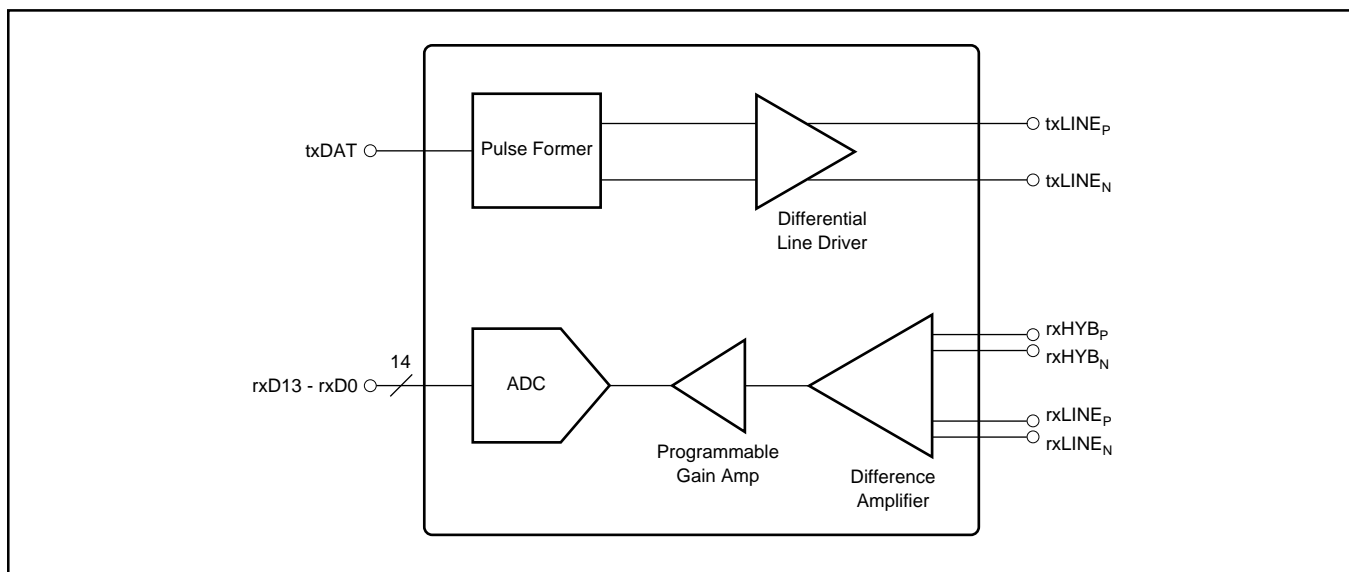

FIGURE 1. Functional Block Diagram of AFE1105.

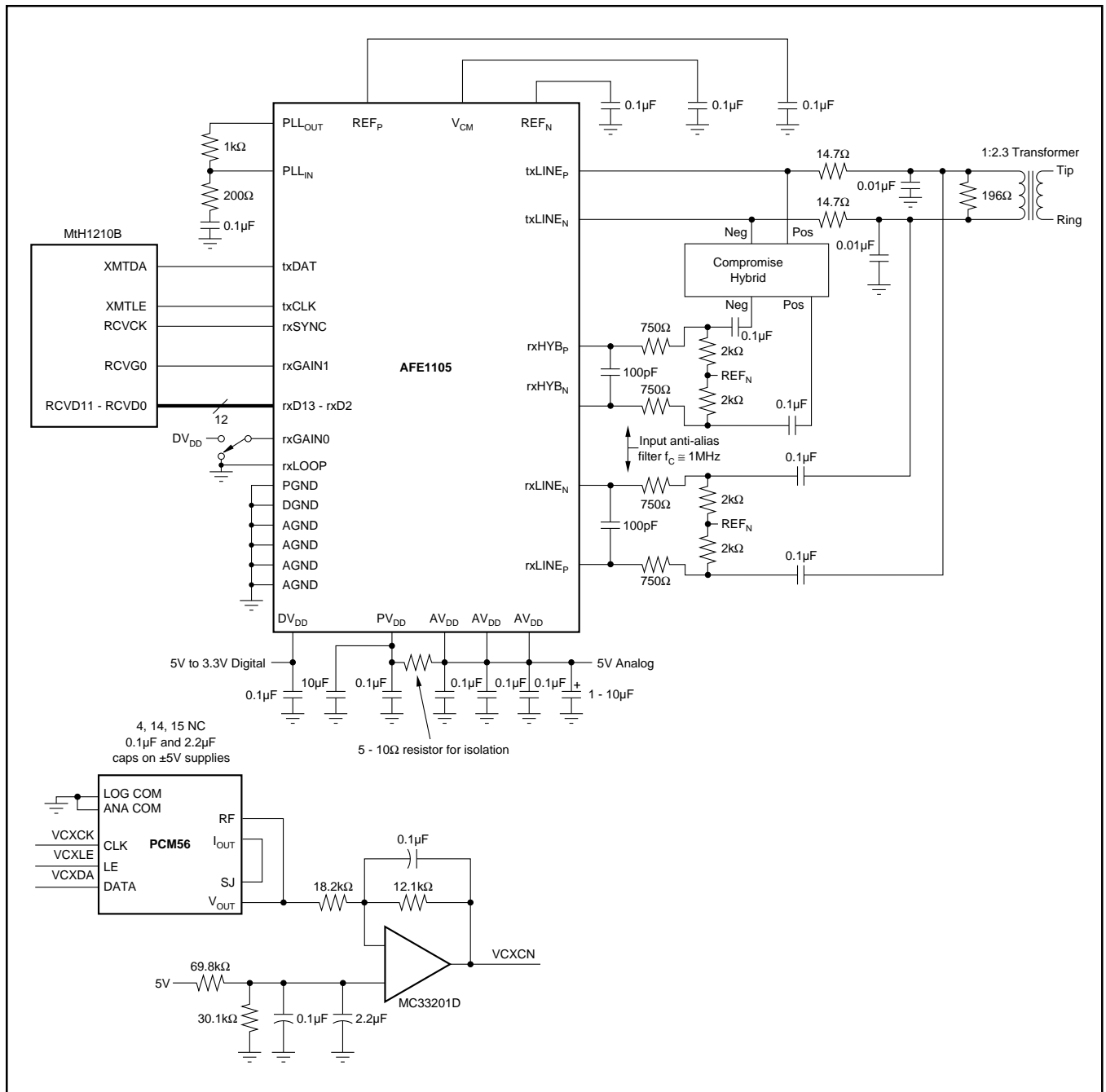

FIGURE 2. Basic Connection Diagram.

### rxHYB AND rxLINE INPUT ANTI-ALIASING FILTERS

The  $-3\text{dB}$  frequency of the input anti-aliasing filter for the rxLINE and rxHYB differential inputs should be about  $1\text{MHz}$ . Suggested values for the filter are  $750\Omega$  for each of the two input resistors and  $100\text{pF}$  for the capacitor. Together the two  $750\Omega$  resistors and the  $100\text{pF}$  capacitor result in  $-3\text{dB}$  frequency of just over  $1\text{MHz}$ . The  $750\Omega$  input resistors will result in a minimal voltage divider loss with the input impedance of the AFE1105.

This circuit applies at both T1 and E1 rates. For slower rates, the antialiasing filters will give best performance with their  $-3\text{dB}$  frequency approximately equal to the bit rate. For example, a  $-3\text{dB}$  frequency of  $500\text{kHz}$  should be used for a single pair bit rate of  $500\text{kbps}$ .

### rxHYB AND rxLINE INPUT BIAS VOLTAGE

The transmitter output on the txLINE pins is centered at midscale,  $2.5\text{V}$ . But, the rxLINE input signal is centered at  $1.5\text{V}$  in the circuit shown in Figure 2 above.

Inside the AFE1105, the rxHYB and rxLINE signals are subtracted as described in the paragraph on echo cancellation above. This means that the rxHYB inputs need to be centered at  $1.5\text{V}$  just as the rxLINE signal is centered at  $1.5\text{V}$ .  $\text{REF}_N$  (Pin 36) is a  $1.5\text{V}$  voltage source. The external compromise hybrid must be designed so that the signal into the rxHYB inputs is centered at  $1.5\text{V}$ .

## TIMING DIAGRAM

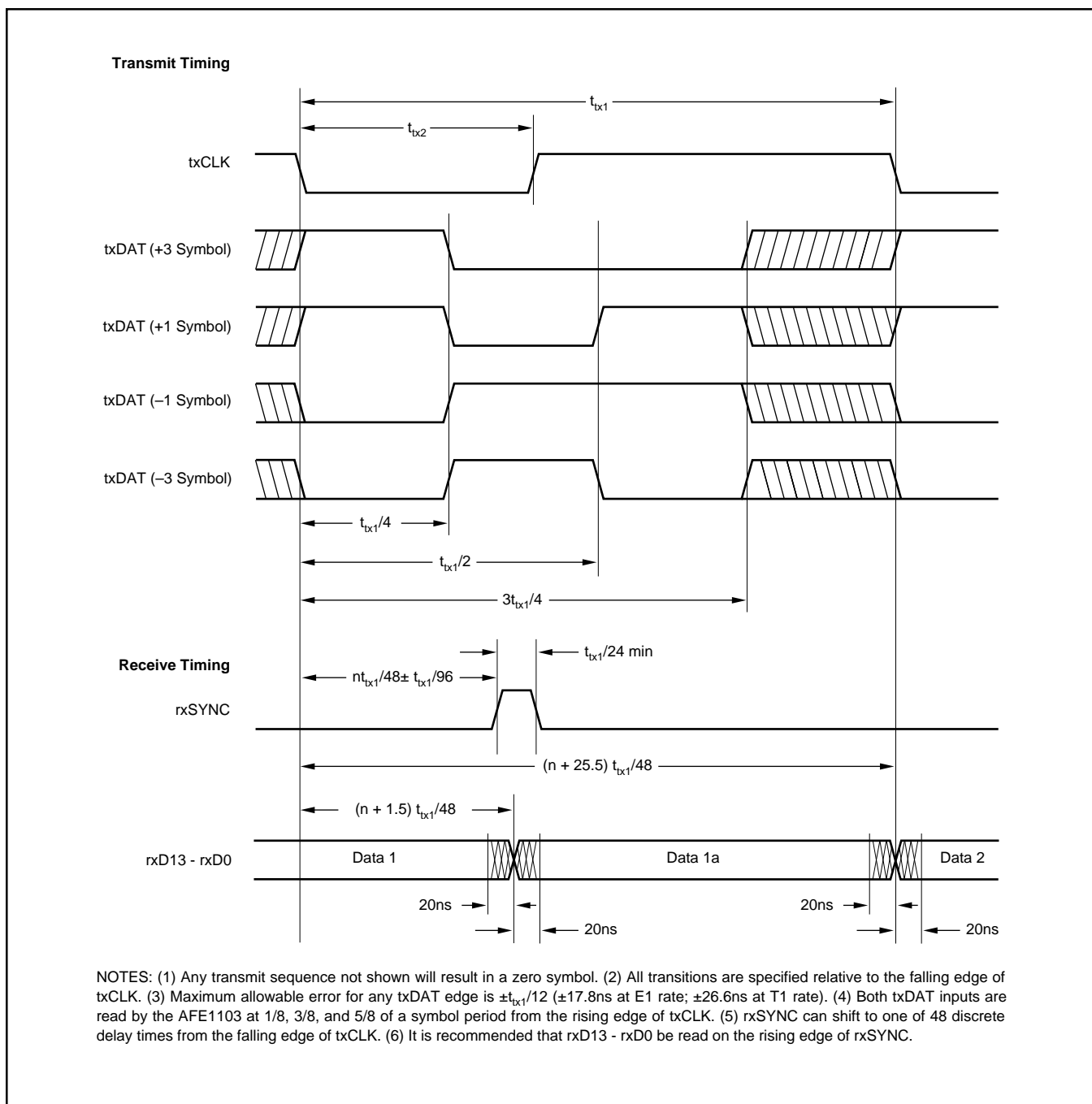

FIGURE 3. Timing Diagram.

## RECEIVE TIMING

The rxSYNC signal controls portions of the A/D converter's decimation filter and the data output timing of the A/D converter. It is generated at the symbol rate by the user and must be synchronized with txCLK. The rising edge of rxSYNC can occur at the falling edge of txCLK or it can be shifted by the user in increments of 1/48 of a symbol period to one of 47 discrete delay times after the falling edge of txCLK.

The bandwidth of the A/D converter decimation filter is equal to one half of the symbol rate. The A/D converter data output rate is 2X the symbol rate. The specifications of the AFE1105 assume that one A/D converter output is used per symbol period and the other interpolated output is ignored. The Receive Timing Diagram above suggests using the rxSYNC pulse to read the first data output in a symbol period. Either data output may be used. Both data outputs may be used for more flexible post-processing.

# DISCUSSION OF SPECIFICATIONS

## UNCANCELLED ECHO

The key measure of transceiver performance is uncanceled echo. This measurement is made as shown in the diagram of Figure 4. The AFE is connected to an output circuit including a typical 1:2 line transformer. The line is simulated by a 135Ω resistor. Symbol sequences are generated by the tester and applied both to the AFE and to the input of an adaptive filter. The output of the adaptive filter is subtracted from the AFE output to form the uncanceled echo signal. Once the filter taps have converged, the RMS value of the uncanceled echo is calculated. Since there is no far-end signal source or additive line noise, the uncanceled echo contains only noise and linearity errors generated in the transmitter and receiver.

The data sheet value for uncanceled echo is the ratio of the RMS uncanceled echo (referred to the receiver input through the receiver gain) to the nominal transmitted signal (13.5dBm into 135Ω, or 1.74Vrms). This echo value is measured under a variety of conditions: with loopback enabled (line input disconnected); with loopback disabled under all receiver gain ranges; and with the line shorted ( $S_1$  closed in Figure 4).

# LAYOUT

The analog front end of an HDSL system has a number of conflicting requirements. It must accept and deliver digital outputs at fairly high rates of speed, phase-lock to a high-speed digital clock, and convert the line input to a high-precision (14-bit) digital output. Thus, there are really three sections of the AFE1105: the digital section, the phase-locked loop, and the analog section.

The power supply for the digital section of the AFE1105 can range from 3.3V to 5V. This supply should be decoupled to digital ground with a ceramic 0.1μF capacitor placed as close to DGND (pin 12) and DV<sub>DD</sub> (pin 13) as possible. Ideally, both a digital power supply plane and a digital ground plane should run up to and underneath the digital pins of the AFE1105 (pins 3 through 26). However, DV<sub>DD</sub> may be supplied by a wide printed circuit board (PCB) trace. A digital ground plane underneath all digital pins is strongly recommended.

The phase-locked loop is powered from PV<sub>DD</sub> (pin 2) and its ground is referenced to PGND (pin 1). Note that PV<sub>DD</sub> must be in the 4.75V to 5.25V range. This portion of the AFE1105 should be decoupled with both a 10μF Tantalum capacitor

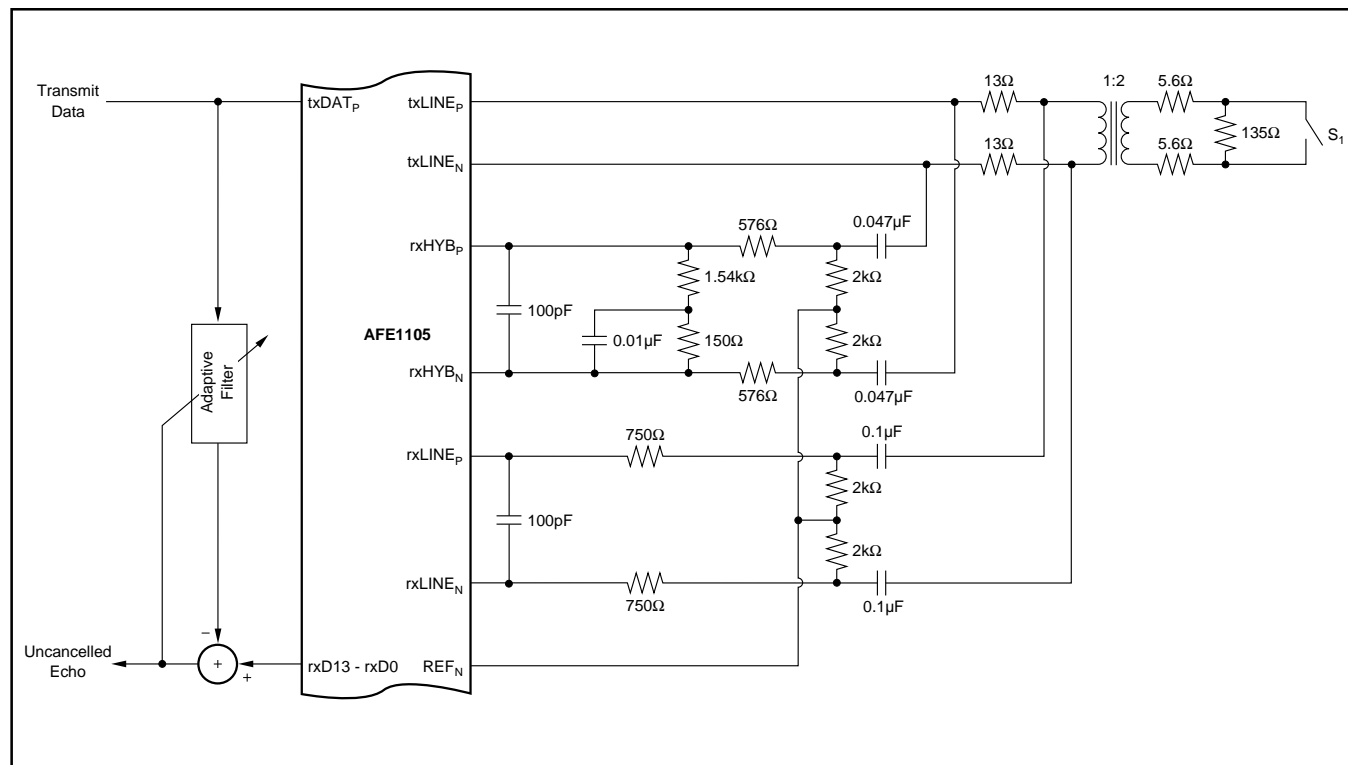

FIGURE 4. Uncanceled Echo Test Diagram.

and a 0.1 $\mu$ F ceramic capacitor. The ceramic capacitor should be placed as close to the AFE1105 as possible. The placement of the Tantalum capacitor is not as critical, but should be close. In each case, the capacitor should be connected between PV<sub>DD</sub> and PGND.

In most systems, it will be natural to derive PV<sub>DD</sub> from the AV<sub>DD</sub> supply. A 5 $\Omega$  to 10 $\Omega$  resistor should be used to connect PV<sub>DD</sub> to the analog supply. This resistor in combination with the 10 $\mu$ F capacitor form a lowpass filter—keeping glitches on AV<sub>DD</sub> from affecting PV<sub>DD</sub>. Ideally, PV<sub>DD</sub> would originate from the analog supply (via the resistor) near the power connector for the printed circuit board. Likewise, PGND should connect to a large PCB trace or small ground plane which returns to the power supply connector underneath the PV<sub>DD</sub> supply path. The PGND “ground plane” should also extend underneath PLL<sub>IN</sub> and PLL<sub>OUT</sub> (pins 47 and 48).

The remaining portion of the AFE1105 should be considered analog. All AGND pins should be connected directly to a common analog ground plane and all AV<sub>DD</sub> pins should be connected to an analog 5V power plane. Both of these planes should have a low impedance path to the power supply.

Ideally, all ground planes and traces and all power planes and traces should return to the power supply connector before being connected together (if necessary). Each ground and power pair should be routed over each other, should not overlap any portion of another pair, and the pairs should be separated by a distance of at least 0.25 inch (6mm). One exception is that the digital and analog ground planes should be connected together underneath the AFE1105 by a small trace.

This datasheet has been downloaded from:

[www.DatasheetCatalog.com](http://www.DatasheetCatalog.com)

Datasheets for electronic components.



LittleDiode supplies new, hard to find or obsolete electronic components and semiconductors all over the world.

With over two million different components listed you are sure to find the part you need.

Feel free to visit us today at our online store:

[LittleDiode.com](http://LittleDiode.com)

Looking forward to providing you with the best possible service.