

2-Cell, Step-Up DC/DC Converter Controller

FEATURES

- Adjustable Output Voltage with Two Resistors (AIC1630A).
- Power-Saving Shutdown Mode (7 μ A typical).
- 120KHz Switching Rate.
- On-Chip Low Battery Detector.

APPLICATIONS

- Palmtop & Notebook Computers.
- Battery Charger Supply.
- Cellular Telephone.
- LCD Contrast Supply.
- Flash Memory Programmer.
- Battery Backup Supplies.
- Portable Instruments.

DESCRIPTION

The AIC1630 is a DC-DC converter designed to drive an external power switch for more flexibility, especially in higher voltage and larger power applications. Typically six components are required to set up a step up configuration easily achieving efficiency beyond 80%. A few more components are required to set up a step down configuration delivering 4A load current with 83% typical efficiency, 86% at 2A load, and 300 μ A quiescent current.

The output voltage is internally set to 3V, 3.3V, 5V or externally set to an arbitrary value below breakdown voltage of the power switch. Logic-controlled shutdown mode is provided for power saving. The low battery detector can be also configured as a linear regulator.

120KHz switching rate reduces the inductor size. Inductors of 25 μ H to 50 μ H inductance are recommended for most applications.

TYPICAL APPLICATION CIRCUIT

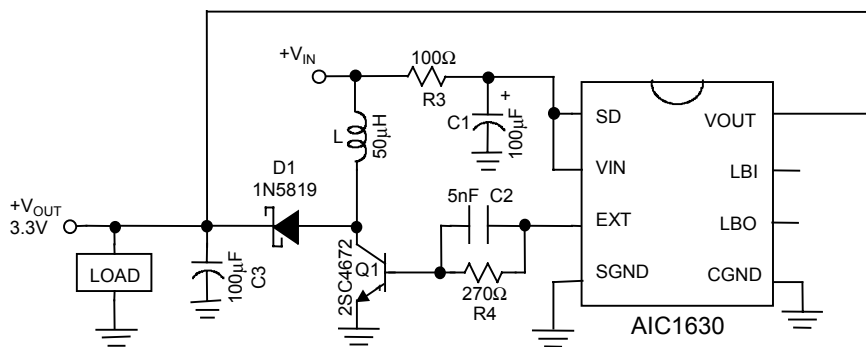

Note : $V_{IN} \geq 1.8V$, $V_{OUT} \leq 7V$

High Efficiency Step-Up DC/DC Converter

ORDERING INFORMATION

AIC1630 XXX

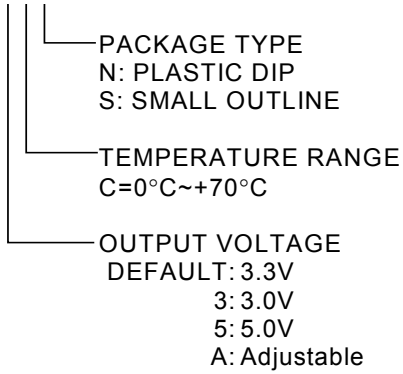

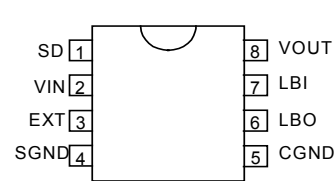
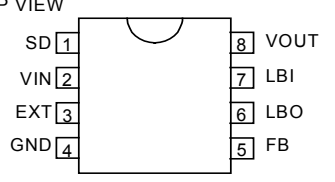
ORDER NUMBER	PIN CONFIGURATION
AIC1630CN AIC1630-3CN AIC1630-5CN (PLASTIC DIP)	<p>TOP VIEW</p> 
AIC1630CS AIC1630-3CS AIC1630-5CS (PLASTIC SO)	
AIC1630ACN (PLASTIC DIP)	<p>TOP VIEW</p> 
AIC1630ACS (PLASTIC SO)	

ABSOLUTE MAXIMUM RATINGS

Supply Voltage	7.0V
DC Voltage Applied On All Other Pins	7.0V
Operating Temperature Range	-20°C~80°C
Storage Temperature Range	-65°C ~150°C

TEST CIRCUIT

Refer to Typical Application Circuit.

ELECTRICAL CHARACTERISTICS ($V_{IN}=3.0V$, $T_a=25^{\circ}C$, unless otherwise specified.)

PARAMETER	TEST CONDITIONS	MIN.	TYP.	MAX.	UNIT
Input Voltage		1.8		7	V
Default Output Voltage	$I_L=200mA$ AIC1630 AIC1630-3 AIC1630-5	3.16 2.88 4.80	3.3 3.0 5.0	3.44 3.12 5.20	V
Switch Off Current			105	140	μA
Shutdown Mode Current			7	15	μA
Recovery Time from Shutdown	$V_{IN}=2.5V$, $I_L=200mA$		0.4		mS
Efficiency	$I_L=300mA$ Fig. 1 in Appl. Examples		85		%
Line Regulation	$V_{IN}=2.2\sim 3.3V$ $V_{OUT}=5V$, $I_L=100mA$		0.6		$\%V_{OUT}$
Load Regulation	$I_L=10mA\sim 500mA$ $V_{OUT}=5V$		2.5		$\%V_{OUT}$
Oscillator Frequency		90	120	150	KHz
LBI Pin Trip Point		1.17	1.22	1.27	V
FB Threshold Voltage	AIC1630A	0.598	0.617	0.636	V
EXT Pin Driving Capability	Pin 8=5V, Pin 3= 0.85V Sourcing Sinking		80 50		mA mA
LBO "ON Resistance"	$V_{IN}=2V$		45		Ω
Input Pin Bias Current				10	nA/Pin
Output Pin Leakage				10	nA/Pin

TYPICAL PERFORMANCE CHARACTERISTICS

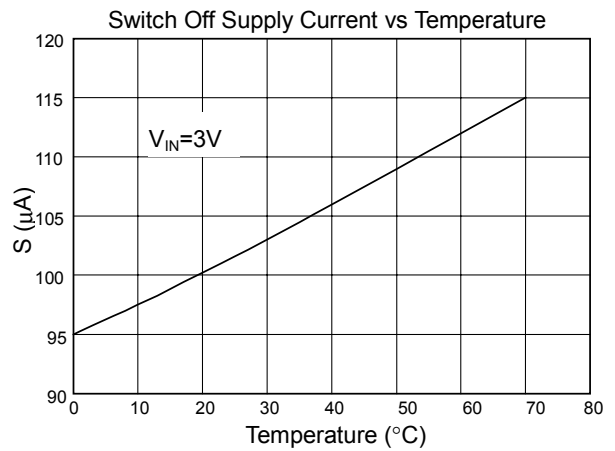
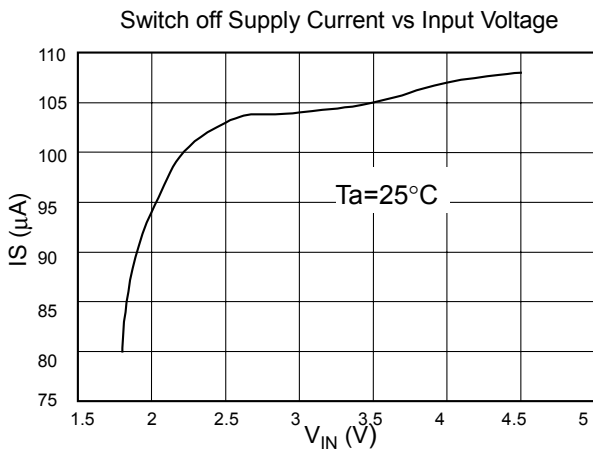
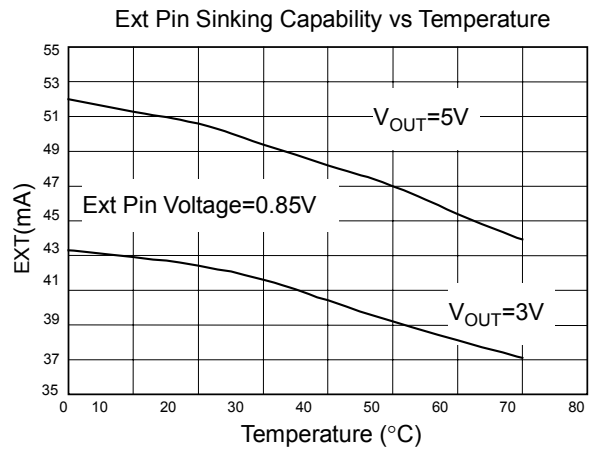
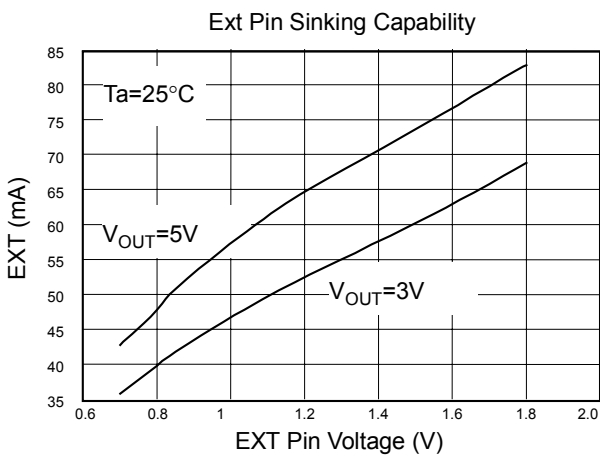
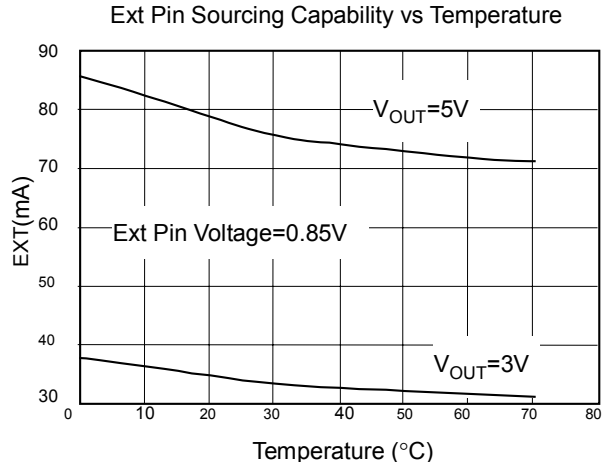
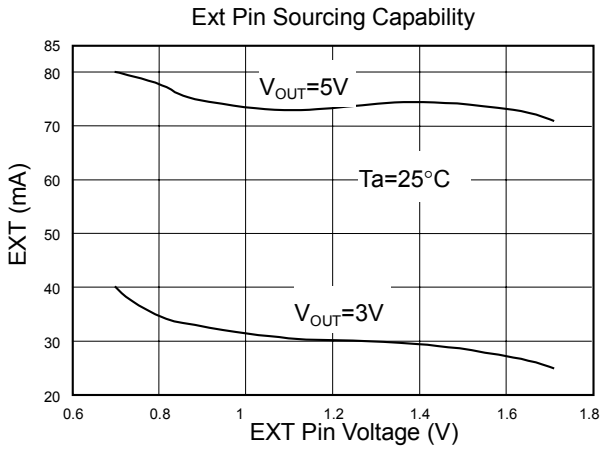

TYPICAL PERFORMANCE CHARACTERISTICS (CONTINUED)

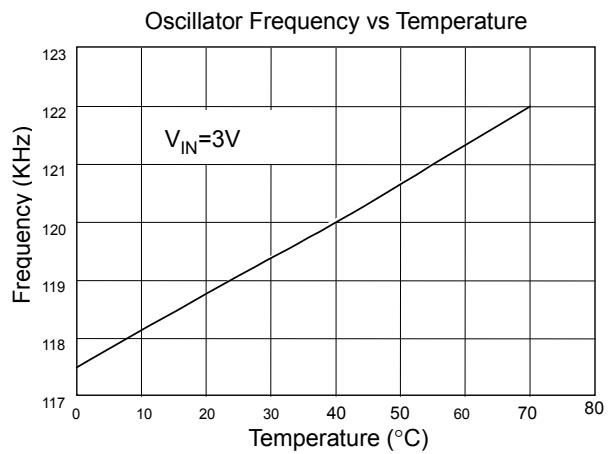
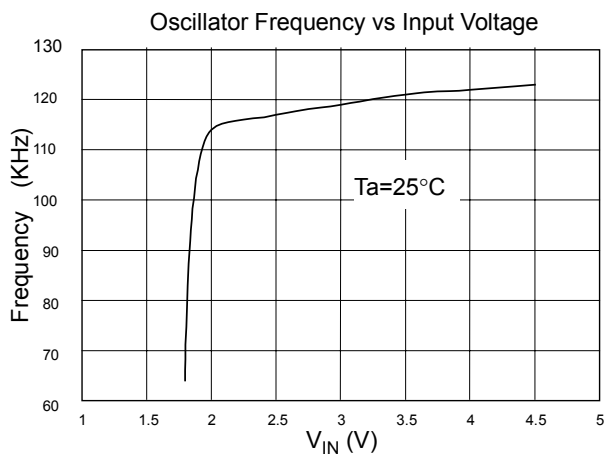
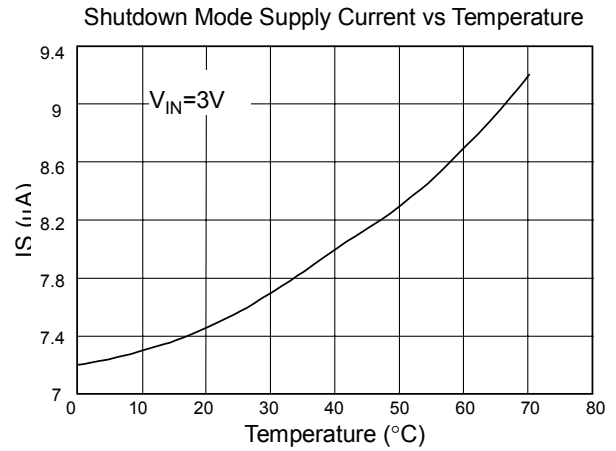
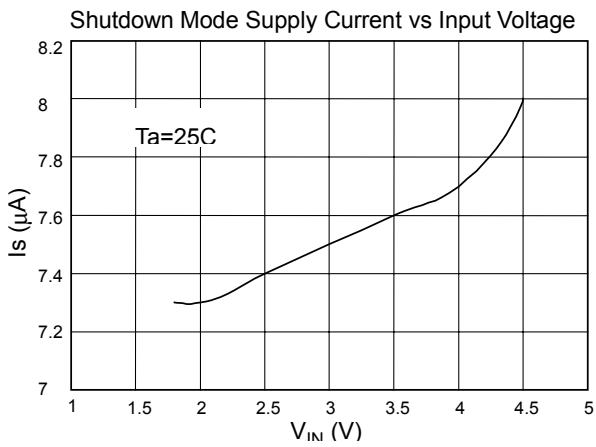

BLOCK DIAGRAM

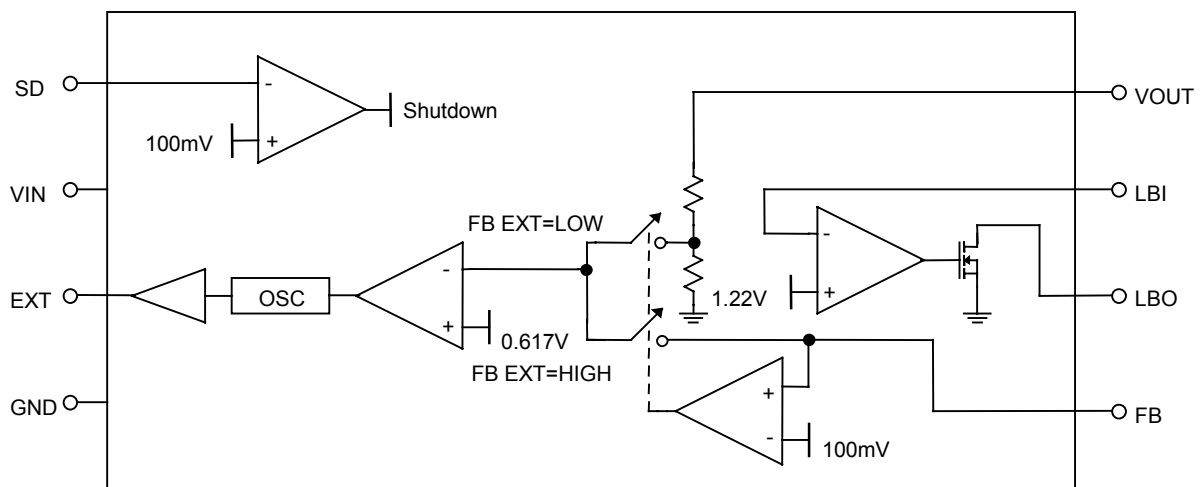

■ PIN DESCRIPTION

AIC1630/ AIC1630-3 / AIC1630-5

- PIN 1: SD - The AIC1630 goes in shutdown mode and consumes less than 10 μ A when SD pin is pulled to ground and it goes in normal operating mode when the SD pin is pulled to a positive voltage above 100mV.
- PIN 2: VIN - Input supply.
- PIN 3: EXT - Push-pull drive output to drive external power switch.
- PIN 4:SGND - Ground connected to source of power switch.
- PIN 5:CGND - Ground for control circuits of the IC. It should be separated from SGND to avoid the interference.
- PIN 6:LBO - Open drain output of the battery low detector, with 45 Ω "ON resistance" at $V_{IN}=2V$. It is pulled low when the voltage on LBI pin is below 1.22V.
- PIN 7:LBI - The noninverting input of the battery low detector, of which the inverting input is internally connects to 1.22V voltage reference.
- PIN 8:VOUT - The output voltage feedbacks to the IC through this pin.

AIC1630A

- PIN 1: SD - The AIC1630A goes in shutdown mode and consumes less than 10 μ A when SD pin is pulled to ground and it goes in normal operating mode when the SD pin is pulled to a positive voltage above 100mV.
- PIN 2: VIN - Input supply.
- PIN 3: EXT - Push-pull drive output to drive external power switch.
- PIN 4: GND - Ground.
- PIN 5: FB - Output voltage can either be internally set to 5 volt by grounding FB pin, or be externally set to an arbitrary voltage by applying to FB pin the divider voltage of two divider resistors.

 V_{OUT} voltage is given by the following equation:

$$\frac{R1}{R2} = \frac{V_{OUT}}{0.617} - 1$$

 where R1 = Resistor connected between FB pin and VOUT pin.
 R2= Resistor connected between FB pin and ground.

 V_{OUT} =Output voltage to be set.
- PIN 6: LBO - Open drain output of the battery low detector, with 45 Ω "ON resistance" at $V_{IN}=2V$. It is pulled low when the voltage on LBI pin is below 1.22V.
- PIN 7: LBI - The noninverting input of the battery low detector, of which the inverting input is internally connects to 1.22V voltage reference.
- PIN 8: VOUT- The output voltage feedbacks to the IC through this pin. If output voltage was externally set, the VOUT pin can be tied to any low impedance node with voltage between the external power switch threshold and 7V

APPLICATION EXAMPLES

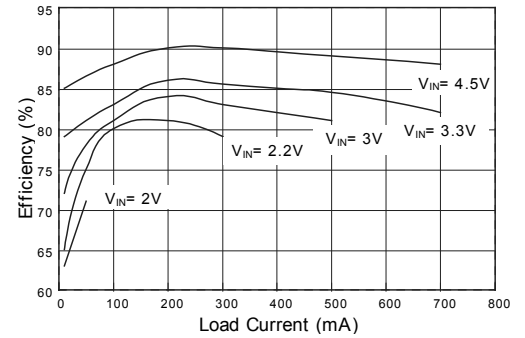
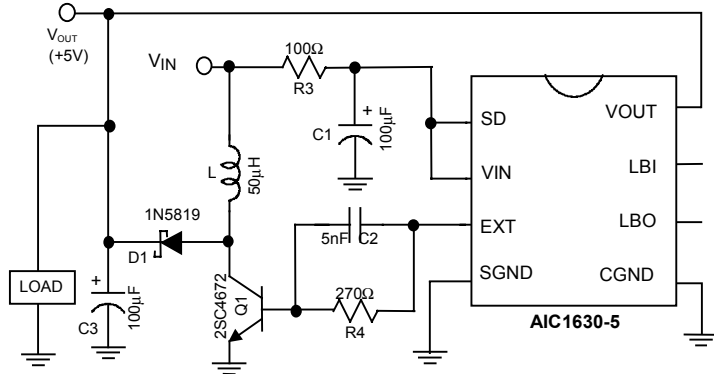

Fig. 1 5V Output Step-Up Converter

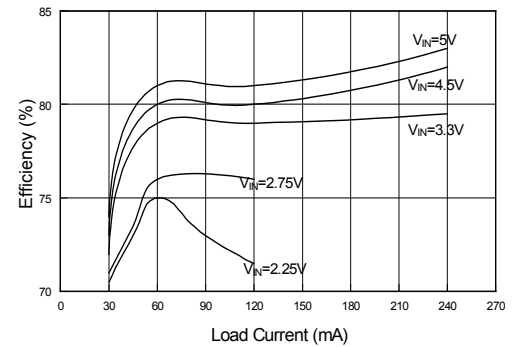
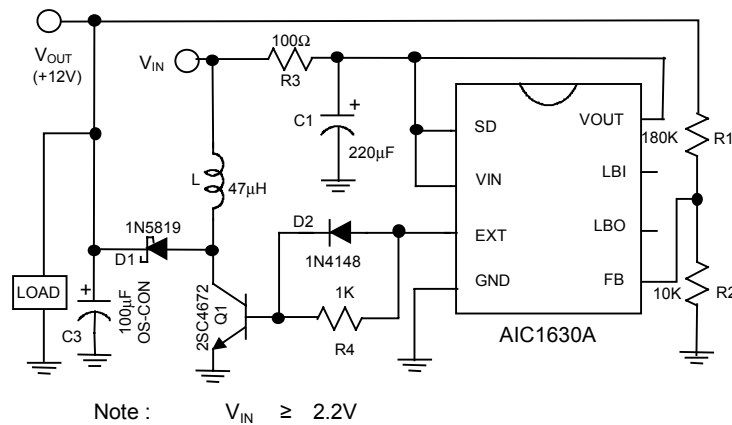

Fig. 2 12V Output Step-Up Converter for Flash Memory

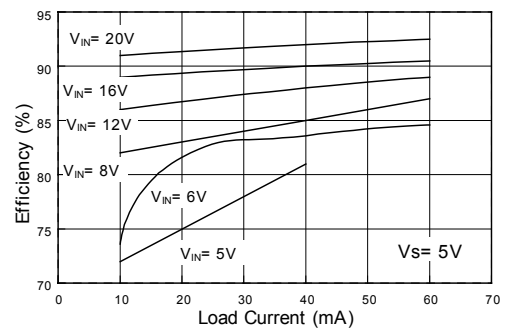
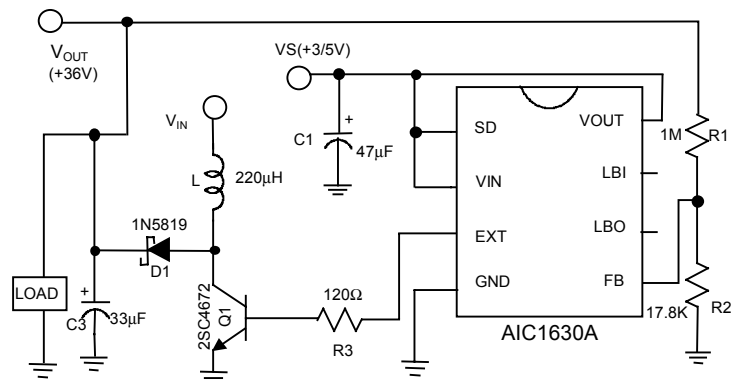

Fig. 3 36V Output Step-Up Converter for Color LCD

APPLICATION EXAMPLES (CONTINUED)

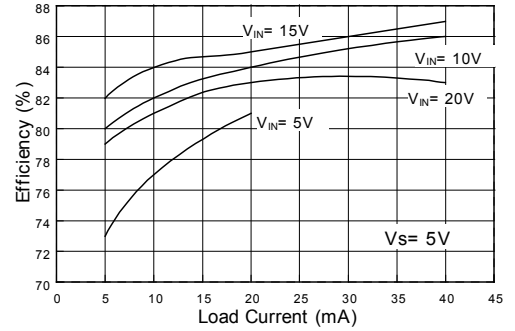
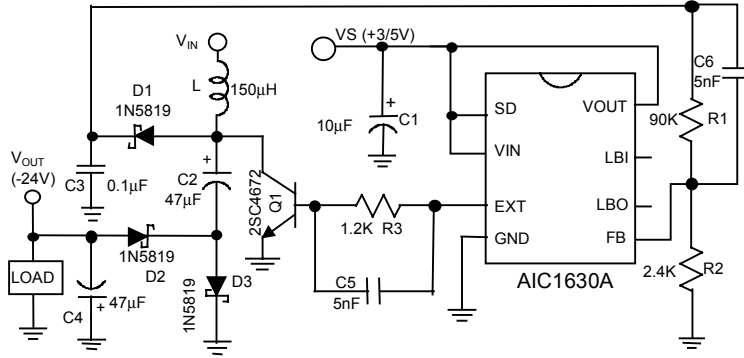

Fig. 4 -24V Output Inverting Converter for LCD

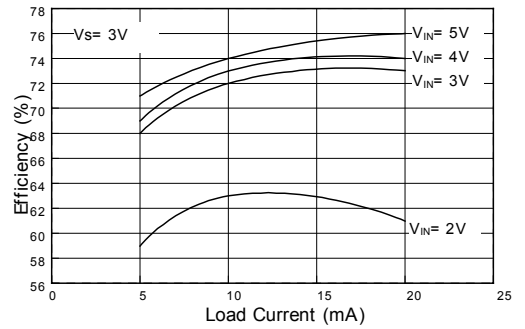
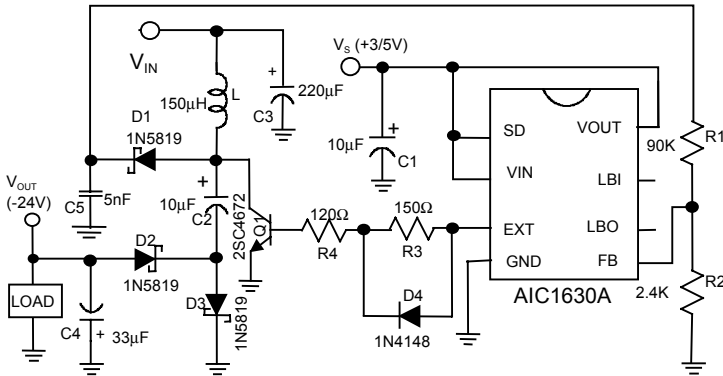

Fig. 5 2V Input 20mA Load -24V Output Inverting Converter for LCD

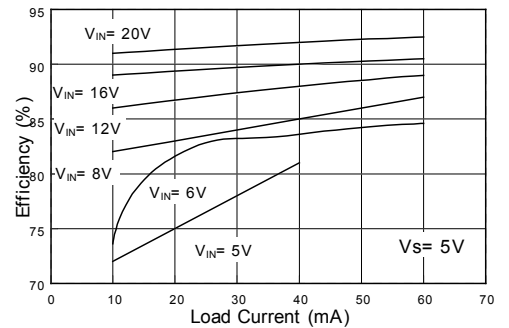
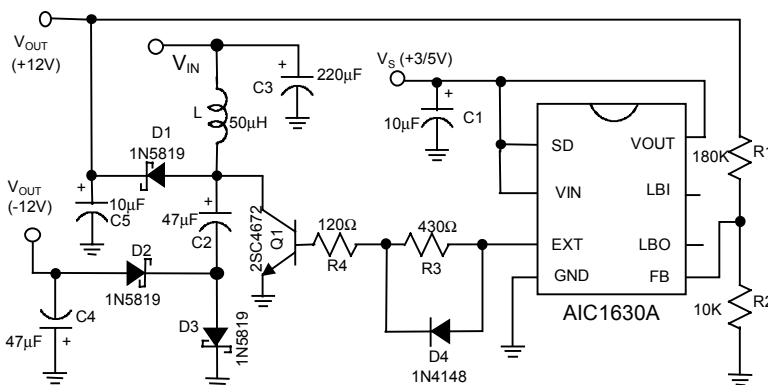

Fig. 6 12V Dual Output Converter for computer for computer Interfacing

APPLICATION EXAMPLES (CONTINUED)

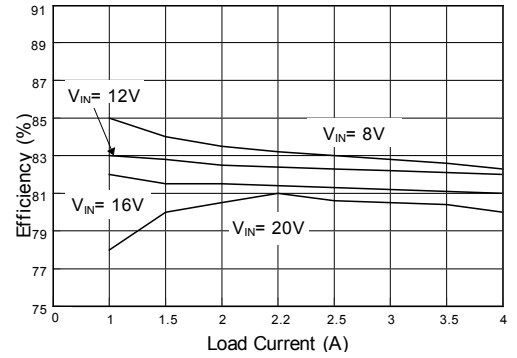
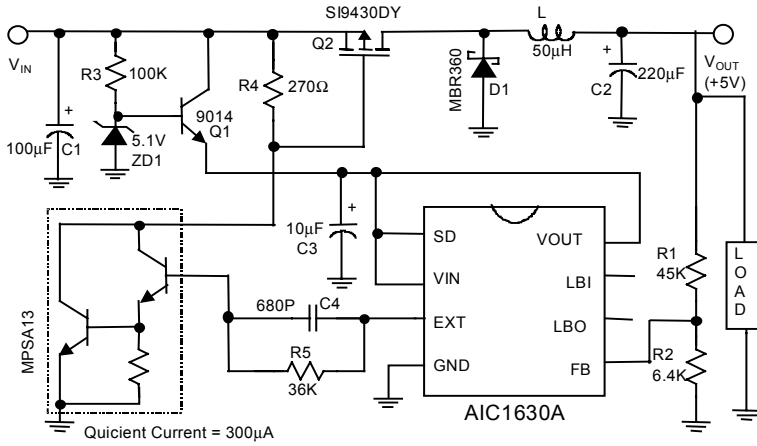

Fig. 7 5V Output Step-Down Converter -1

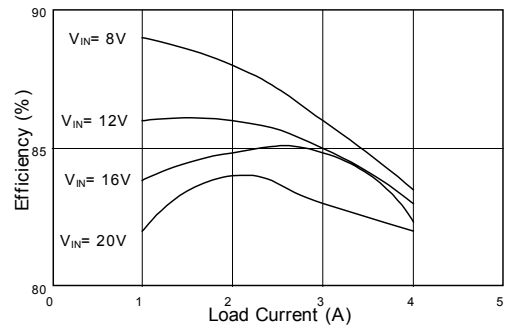
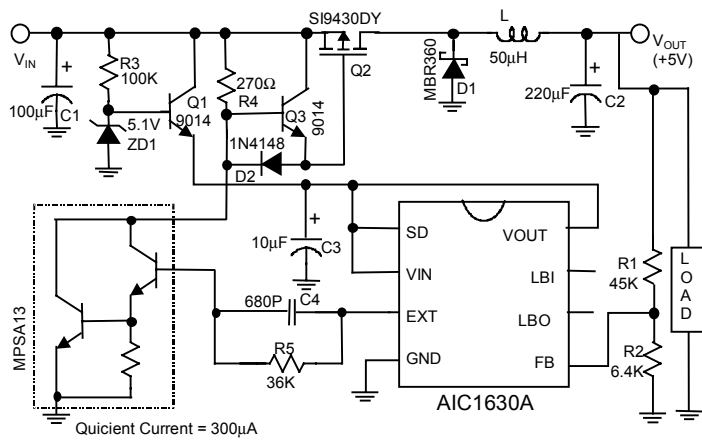
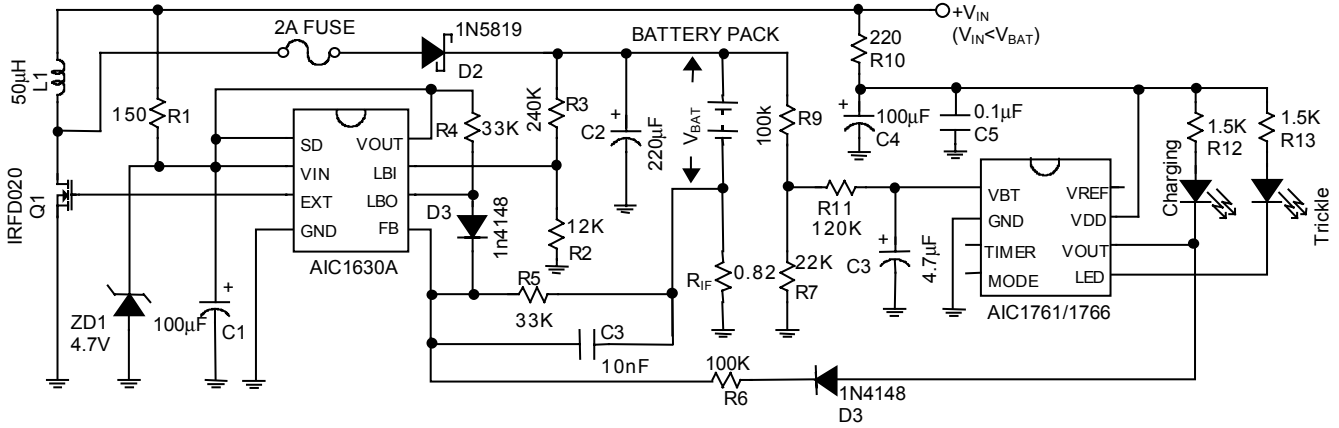

Fig. 8 5V Output Step-Down Converter -2

APPLICATION EXAMPLES (CONTINUED)



Note: $V_{IN} \geq 2.2V$
 Charging current = 0.8A, Auto-Cut-Off at 0.75/0.25% ΔV point and Fault Conditions.
 (R_{IF} sets the Charging Current)
 V_{IN} must be lower than V_{BAT} .
 Short Circuit Condition is protected with a 2A Fuse.

Fig. 9 Step-Up Rechargeable Battery Charger

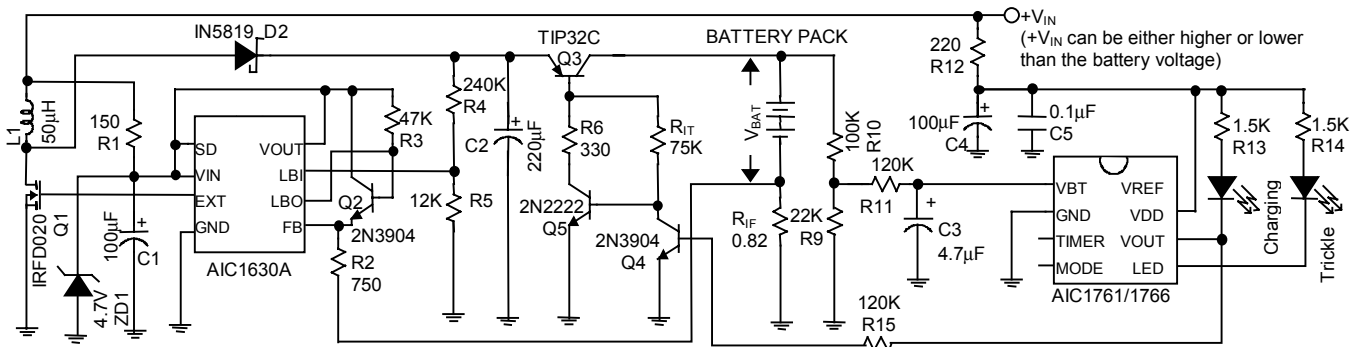

Note: Fast Charge Current = $0.8A @ V_{IN} < V_{BAT}$
 = $(V_{IN} - V_{BAT} - 0.5)/0.82 @ V_{IN} > V_{BAT}$
 Trickle charge Current = 30mA.
 (R_{IF} sets Fast Charge Current, R_{IT} sets Trickle Charge Current)
 Typical Efficiency = 75%.
 With Short Circuit Protection.

Fig. 10 Step-Up/Down Rechargeable Battery Charger

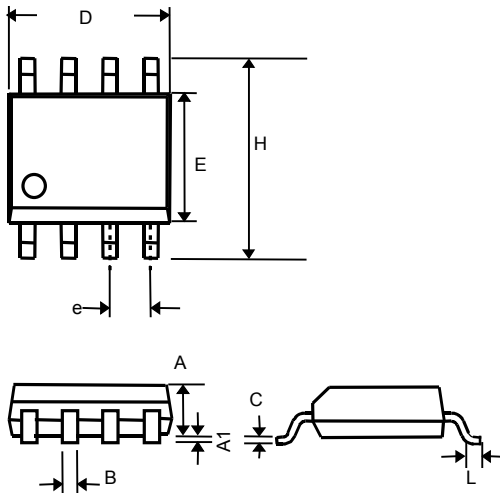
PHYSICAL DIMENSIONS
8 LEAD PLASTIC SO (unit: mm)

SYMBOL	MIN	MAX
A	1.35	1.75
A1	0.10	0.25
B	0.33	0.51
C	0.19	0.25
D	4.80	5.00
E	3.80	4.00
e	1.27(TYP)	
H	5.80	6.20
L	0.40	1.27

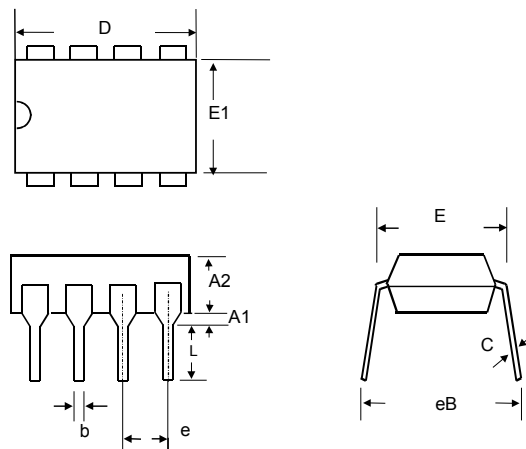
8 LEAD PLASTIC DIP (unit: mm)

SYMBOL	MIN	MAX
A1	0.381	—
A2	2.92	4.96
b	0.35	0.56
C	0.20	0.36
D	9.01	10.16
E	7.62	8.26
E1	6.09	7.12
e	2.54 (TYP)	
eB	—	10.92
L	2.92	3.81



LittleDiode supplies new, hard to find or obsolete electronic components and semiconductors all over the world.

With over two million different components listed you are sure to find the part you need.

Feel free to visit us today at our online store:

LittleDiode.com

Looking forward to providing you with the best possible service.