

**AK2305****Dual PCM CODEC for ISDN TERMINAL ADAPTER****GENERAL DESCRIPTION**

AK2305 is a dual PCM CODEC-Filter most suitable for ISDN Terminal Adapter. A-law/u-law is selected by the internal register. In addition to CODEC, this device has dual DTMF receiver and External Tone Input pin.

Input/output operational amplifiers included in this device are used for transmit/receive gain adjustment. AK2305 has internal volume control to attenuate signal from 0dB to -12dB by 3dB step control which is defined by an internal register written through the serial interface.

PCM interface of AK2305 accepts several clock formats, which are Long Frame, Short Frame, GCI, IDL. 64k-4096kHz clock input is available for PCM interface.

FEATURE

- **Dual PCM CODEC and Filtering systems for ISDN Terminal Adapter**
- **Dual DTMF Receiver**
- **External Tone Input(AUX)**
- **Independent functions on each channel**
 - **Frame Sync Signal(8kHz)**
 - **Power Down Mode(Pin/Register operation)**
 - **Mute(Pin/Register operation)**
 - **Gain Adjustment: 0 to -12dB (3dB step)**
- **Selectable PCM Data Interface Timing: Long Frame / Short Frame / GCI / IDL**
- **Variable PCM Data Rate: 64k x N [Hz] (64k - 4.096MHz)**
- **Operational Amplifier for Gain Adjustment**
- **A-law/u-law Register Selectable**
- **Serial Interface**
- **Power on Reset**
- **Single +5V ± 5% CMOS technology**
- **Low Power Consumption (85mW typ)**

PACKAGE

- **48LQFP**
9.0 x 9.0 mm (0.5mm pin pitch)

CONTENTS

ITEMS	PAGE
- BLOCK DIAGRAM.....	3
- PIN ASSIGNMENT.....	4
- PIN CONDITION.....	5
- PIN FUNCTION.....	6
- CIRCUIT DESCRIPTION.....	8
- FUNCTIONAL DESCRIPTION.....	9
- PCM INTERFACE.....	9
LONGFRAME/SHORTFRAME.....	10
GCI.....	12
IDL.....	13
RESET.....	14
- POWER DOWN.....	15
- MUTE.....	17
- GAIN ADJUSTMENT.....	18
- DTMF RECEIVER.....	19
- TONE GENERATOR.....	21
- AUX INPUT.....	21
- SERIAL INTERFACE.....	22
- REGISTER.....	25
- ABSOLUTE MAXIMUM RATINGS.....	28
- RECOMMENDED OPERATING CONDITIONS.....	28
- ELECTRICAL CHARACTERISTICS.....	28
- APPLICATION CIRCUIT EXAMPLE.....	39
- PACKAGE INFORMATION.....	42

BLOCK DIAGRAM

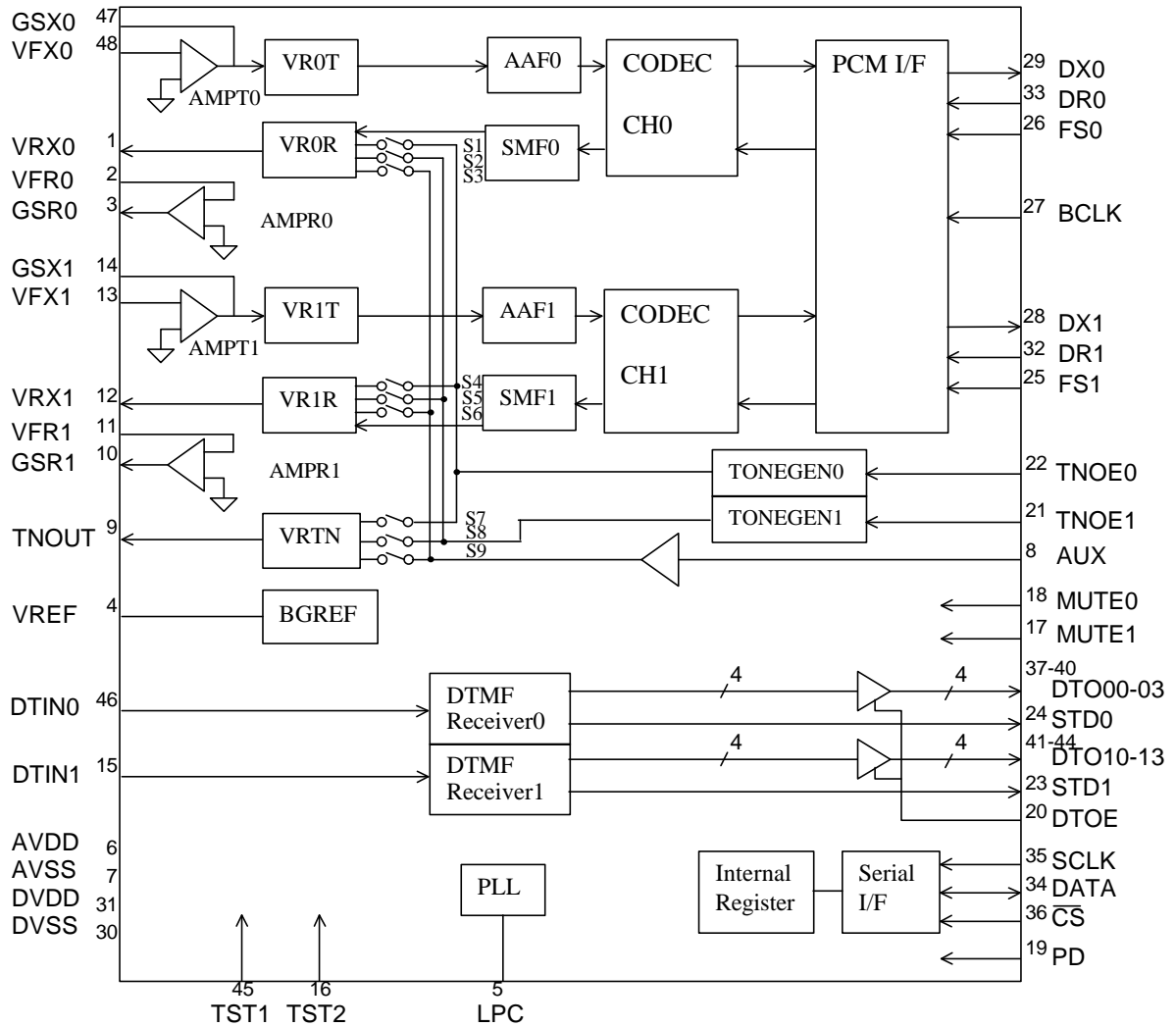

PIN ASSIGNMENT

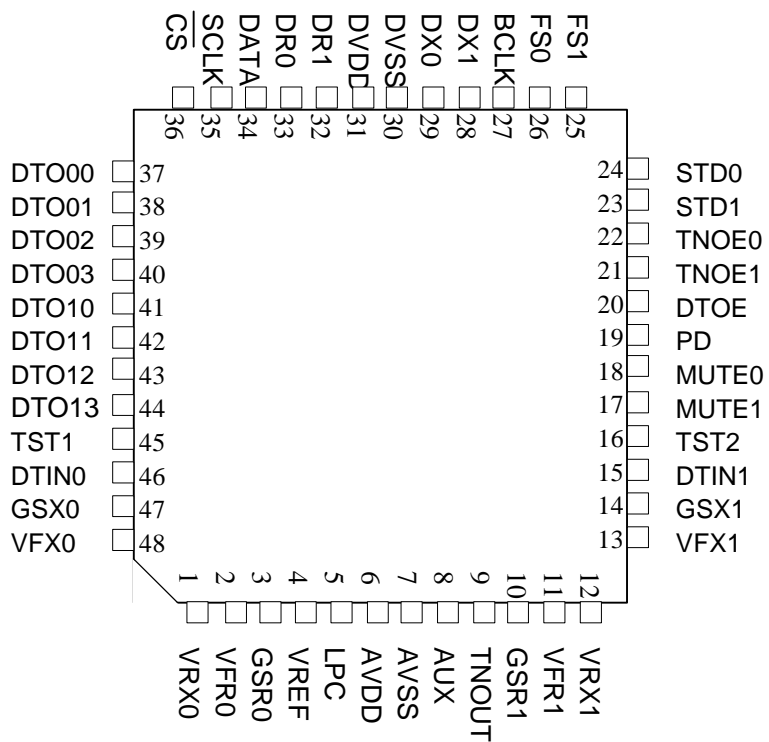

PIN CONDITION

Pin#	Name	I/O	Pin type	AC load (MAX.)	DC load (MIN.)	Output status (Power down mode)	Output status (Reset)	Remarks
1	VRX0	O	Analog	50pF	10kΩ	Hi-Z	Hi-Z	
2	VFR0	I	Analog					
3	GSR0	O	Analog	50pF	10kΩ (*1)	Hi-Z	Hi-Z	
4	VREF	O	Analog					external cap
5	LPC	O	Analog					external cap
6	AVDD	-						
7	AVSS	-						
8	AUX	I	Analog					
9	TNOUT	O	Analog	50pF	10kΩ	Hi-Z	Hi-Z	
10	GSR1	O	Analog	50pF	10kΩ (*1)	Hi-Z	Hi-Z	
11	VFR1	I	Analog					
12	VRX1	O	Analog	50pF	10kΩ	Hi-Z	Hi-Z	
13	VFX1	I	Analog					
14	GSX1	O	Analog	50pF	10kΩ (*1)	Hi-Z	Hi-Z	
15	DTIN1	I	Analog					
16	TST2	I	TTL					Factory use only
17	MUTE1	I	TTL					
18	MUTE0	I	TTL					
19	PD	I	TTL					
20	DTOE	I	TTL					
21	TNOE1	I	TTL					
22	TNOE0	I	TTL					
23	STD1	O	CMOS	15pF		L	L	
24	STD0	O	CMOS	15pF		L	L	
25	FS1	I	TTL					(*2)
26	FS0	I	TTL					
27	BCLK	I	TTL					
28	DX1	O	CMOS	15pF		Hi-Z	Hi-Z	
29	DX0	O	CMOS	15pF		Hi-Z	Hi-Z	
30	DVSS	-						
31	DVDD	-						
32	DR1	I	TTL					(*3)
33	DR0	I	TTL					
34	DATA	I/O	TTL/CMOS	15pF		Input	Input	
35	SCLK	I	TTL					
36	CSN	I	TTL					
37	DTO00	O	CMOS	15pF		Hi-Z	Hi-Z	
38	DTO01	O	CMOS	15pF		Hi-Z	Hi-Z	
39	DTO02	O	CMOS	15pF		Hi-Z	Hi-Z	
40	DTO03	O	CMOS	15pF		Hi-Z	Hi-Z	
41	DTO10	O	CMOS	15pF		Hi-Z	Hi-Z	
42	DTO11	O	CMOS	15pF		Hi-Z	Hi-Z	
43	DTO12	O	CMOS	15pF		Hi-Z	Hi-Z	
44	DTO13	O	CMOS	15pF		Hi-Z	Hi-Z	
45	TST1	I	TTL					Factory use only
46	DTIN0	I	Analog					
47	GSX0	O	Analog	50pF	10kΩ (*1)	Hi-Z	Hi-Z	
48	VFX0	I	Analog					

*1) DC load(MIN.) includes a feedback resistance of input/output op-amp. *2) Pulled down to VSS in GCI/IDL mode.

*3) Pulled down to VSS in 2ch Multiplex mode.

PIN FUNCTION

Pin#	Name	I/O	Function
48	VFX0	I	Transmit analog input. Inverting input of transmit gain adjustment amplifier for channel 0.
47	G SX0	O	Output of transmit gain adjustment amplifier for channel 0.
1	VRX0	O	Receive analog output of SMF for channel 0. This output can drive 10kΩ and 50pF.
2	VFX0	I	Transmit analog input. Inverting input of transmit gain adjustment amplifier for channel 0.
3	G SR0	O	Output of receive gain adjustment amplifier for channel 0.
10	G SR1	O	Output of receive gain adjustment amplifier for channel 1.
11	VFR1	I	Inverting input of receive gain adjustment amplifier for channel 1.
12	VRX1	O	Receive analog output of SMF for channel 1. This output can drive 10kΩ and 50pF.
14	G SX1	O	Output of transmit gain adjustment amplifier for channel 1.
13	VFX1	I	Transmit analog input. Inverting input of transmit gain adjustment amplifier for channel 1.
29	DX0	O	Serial output of PCM data of ch0. In Long Frame / Short Frame mode, output PCM data of ch0. In GCI / IDL mode, output PCM data of ch0 is multiplexed with ch1. The PCM data rate is synchronized with BCLK. See "PCM INTERFACE" from page 9. This output remains in the high impedance state except for the period of transmitting PCM data.
33	DR0	I	Serial input of PCM data of ch0. In Long Frame / Short Frame mode, input PCM data of ch0. In GCI / IDL mode, input PCM data of ch0 is multiplexed with ch1. The PCM data rate is synchronized with BCLK. See "PCM INTERFACE" from page 9.
28	DX1	O	Serial output of PCM data of ch1. In Long Frame / Short Frame mode, output PCM data of ch1. The PCM data rate is synchronized with BCLK. See "PCM INTERFACE" from page 9. This output remains in the high impedance state except for the period of transmitting PCM data. In 2ch multiplexd mode, this pin remains in the high impedance state.
32	DR1	O	Serial input of PCM data of ch1. In Long Frame / Short Frame mode, input PCM data of ch1. The PCM data rate is synchronized with BCLK. See "PCM INTERFACE" from page 9. In GCI / IDL mode, this pin is pulled down to VSS.
26	FS0	I	Frame sync input for channel 0. FS0 must be 8KHz clock synchronized in BCLK.

Pin#	Name	I/O	Function
25	FS1	I	Frame sync input for channel 1. FS1 must be 8KHz clock synchronized in BCLK. In GCI / IDL mode, this pin is pulled down to VSS.
27	BCLK	I	Bit clock of PCM data interface. This clock is apply for both ch0 and ch1. BCLK should be synchronized with $8 \times N$ kHz($FS_n \times N$ kHz).
46	DTIN0	I	DTMF tone input of ch 0.
37	DTO00	O	Output of DTMF receiver 0. DTO00 is LSB.
38	DTO01	O	
39	DTO02	O	
40	DTO03	O	
24	STD0	O	
15	DTIN1	I	DTMF tone input.
41	DTO10	O	Output of DTMF receiver 1. DTO10 is LSB.
42	DTO11	O	
43	DTO12	O	
44	DTO13	O	
23	STD1	O	Steering to delay output of ch0. After the DTMF decoding, the output latch is renewed and this output alters to high level.
20	DTOE	I	Output enable pin for the DTMF receiver.
22	TNOE0	I	Output enable pin for the tone generator 0.
21	TNOE1	I	Output enable pin for the tone generator 1.
8	AUX	I	External tone input pin. Input signal should be through more than 0.1 μ F of an external capacitance.
9	TNOUT	O	Tone output pin.
34	DATA	I/O	Data input of serial interface.
35	SCLK	I	Clock input of serial interface.
36	\overline{CS}	I	Read and write enable of serial interface.
18	MUTE0	I	Active high input for ch0 mute.
17	MUTE1	I	Active high input for ch0 mute.
19	PD	I	Active high input for all power down.
5	LPC	O	Pin for PLL loop filter. Connect to AVSS with 0.22 μ F or larger.
4	VREF	O	Analog ground output. To stabilize the analog ground, connect to AVSS with 0.1 μ F or larger.
31	DVDD	-	Digital positive supply voltage. System digital +5V supply.
30	DVSS	-	Digital negative supply voltage. System digital ground.
6	AVDD	-	Analog positive supply voltage. Systems analog +5V supply.
7	AVSS	-	Analog negative supply voltage. System analog ground.
45	TST1	I	Only for factory use. Should be fixed to DVSS.
16	TST2	I	

CIRCUIT DESCRIPTION

Block	Function
AMPT0,1	Op-amp for input gain adjustment. This op-amp is used as an inverting amplifier. Adjusting the gain with external resistors. The resistor larger than 10kΩ is recommended for the feedback resistor. <NOTE> AMP0(1) becomes automatically power down, when both CODEC ch0(1) and DTMFR0(1) are power down.
AMPR0,1	Op-amp for output gain adjustment. This op-amp is used as an inverting amplifier. Adjusting the gain with external resistors. The resistor larger than 10kΩ is recommended for the feedback resistor.
AAF	Integrated anti-aliasing filter which prevents signals around the sampling rate from folding back into the voice band. AAF is a 2nd order RC low-pass filter.
A/D	Converts analog signal to 8bit PCM data according to the companding schemes of ITU recommendation G.711; A-law or u-law. The band limiting filter is also integrated. The selection of companding schemes is set by ALAWN register as follows: "H": u-Law "L": A-Law
D/A	Expands 8bit PCM data according to A-law or u-law. The selection of companding schemes is set by ALAWN register as follows: "H": u-Law "L": A-Law
SMF	Extracts the inband signal from D/A output. It also corrects the sinx/x effect of D/A output.
BGREF	Provides the stable analog ground voltage (2.4V) using an on-chip band-gap reference circuit which is temperature compensated.
TONE GEN 0 TONE GEN 1	Generates two kinds of tone; 400Hz and 1300Hz. Tone selection is defined by registers. ON/OFF of tone output is controlled by TNOE0/1.
SWITCH Sn(n=1-9)	Controls output signals from VRX0, VRX1, TNOOUT pins. Each switch is controlled by register.
DTMF Receiver0,1	Detects and decodes the DTMF tone. ON/OFF of decoded output is controlled by DTOE.
VR0T/R VR1T/R VRTN	Gain selects of analog I/O signals. It is possible to select gain from 0dB to -12dB (3dB/step* 5steps). Gain is defined by register.
SERIAL I/F	Interface to internal register by using SCLK, DATA, and \overline{CS} pins. 1word=14bit; Instruction code: 2bit, address: 3bit, data: 9bit(1dummy bit included).
PLL	PLL generates system clock of AK2305. Reference clock is FSn (8KHz). More than 0.22uF of an external capacitance should be connected between LPC and AVSS.
PCM I/F	PCM data rate is available for 64xN(N = 1 to 64)kHz which synchronizes with BCLK. Data format is selected in four types(Long Frame, Short Frame, GCI, IDL). 2ch PCM data are interfaced through DR0,1 and DX0,1 in non multiplexed mode or DR0 and Dx0 in multiplexed mode.

FUNCTIONAL DESCRIPTION

PCM INTERFACE

AK2305 supports the following types of format.

One of those is selected by PCMIF0 and PCMIF1 registers.

- **Long Frame Sync(LF)**
- **Short Frame Sync(SF)**
- **GCI**
- **IDL**

PCM data of both channels are multiplexed and interfaced through the common pins (DR0, DX0) in 2ch Multiplex I/F mode. But in 2ch Independent I/F mode of LF or SF, it is also available to interface through the independent pin(DR0/1,DX0/1) by channel.

Register of PCM interface mode selection

PCMIF1	PCMIF0	Interface	Frame sync	Input pin	Output pin	Remarks
0	0	LF/SF (Non multiplex)	FS0,FS1	DR0,DR1	DX0, DX1	Reset
0	1	LF/SF (2ch multiplex)	FS0,FS1	DR0	DX0	
1	0	GCI (2ch multiplex)	FS0	DR0	DX0	
1	1	IDL (2ch multiplex)	FS0	DR0	DX0	

FRAME SYNC SIGNAL(Frame Sync : FS)

Frame sync signal should be 8kHz clock. 8bits PCM data is accommodated in 1 frame (125us).

Though only FS0 is required (FS1 isn't required) in the mode of GCI or IDL, both FS0 and FS1 are required in the mode of LF or SF.

FIRST FS

It is used as the input clock of PLL. PLL generates all timing in this IC from this signal.

FS0 is assigned as First FS in the mode of GCI or IDL, and in the mode of LF or SF, it is assigned by the first FS register.

1stFS register	First FS	Remarks
0	FS0	Reset
1	FS1	

Note

Keep supplying the first FS except for the state of all power down(PD="H"). If the first FS is not supplied, AK2305 loses timing; at a result, DTMFR and TONE GEN become not guaranteed to work normally.

BCLK

This clock decides the PCM data rate. See the following table of the relation between BCLK and PCM data rate.

PCM I/F mode	BCLK	Rate of PCM data
LF/SF/IDL	F	F
GCI	2F	F

Long Frame Sync(LF) Short Frame Sync(SF)

AK2305 automatically decides whether Long Frame or Short Frame should be selected, by monitoring the high level period of First FS.

Period of First FS = "H"	Frame type
more than 2 clock of BCLK	LF
1 clock of BCLK	SF

INTERFACE TIMING

<2ch Multiplex>

PCM data of both channel are interfaced by the DX0 and DR0(DX1 and DR1 are not used) at the format of 8bits in the period of 1 frame(125us) which synchronizes with the FS_n(n=0,1). In the period of 1frame, 64 time slots can be assigned at the maximum (in case of BCLK=4.096MHz). The number of the time slots is BCLK/64k. The time slot assignment of CH0 and CH1 is decided by FS0 and FS1. In the mode of LF and SF, second FS(not first FS) must be delayed or fast at least (8/BCLK) x n: (n=1 - 63) from the first FS.

LongFrame

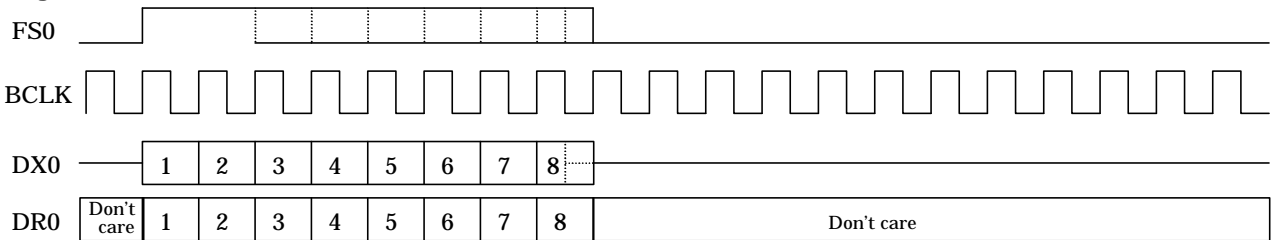

ShortFrame

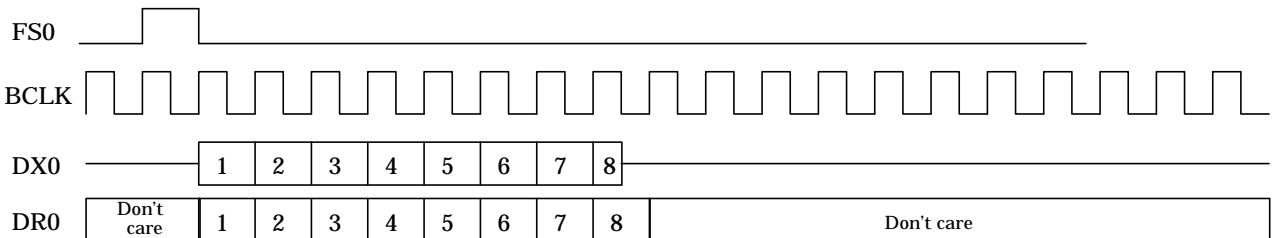

BCLK=4096kHz (First FS = FS0)

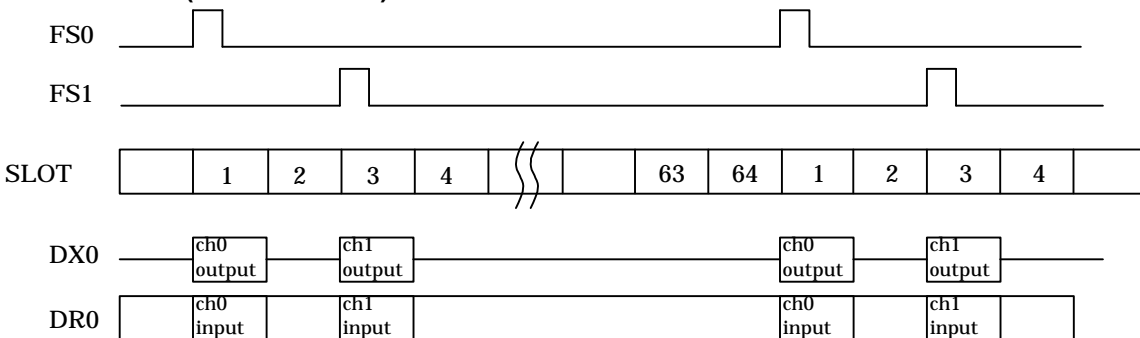

INTERFACE TIMING

<Non Multiplex>

PCM data of each channel are interfaced by each I/O pins(DX0 and DR0/DX1 and DR1) at the format of 8bits in the period of 1 frame(125us) which synchronizes with the FS_n(n=0,1). The timing of FS0 and FS1 can be set at optionally as far as they synchronize with BCLK.

NOTE) First FS and Second FS

Only when BCLK=64kHz, it is possible to input the same clock to the first FS and the second FS. Except for 64kHz BCLK, 8 clock of BCLK x n (n=1-63 integral numbers) intervals of n slots are needed.

BCLK=4096kHz (First FS = FS0)

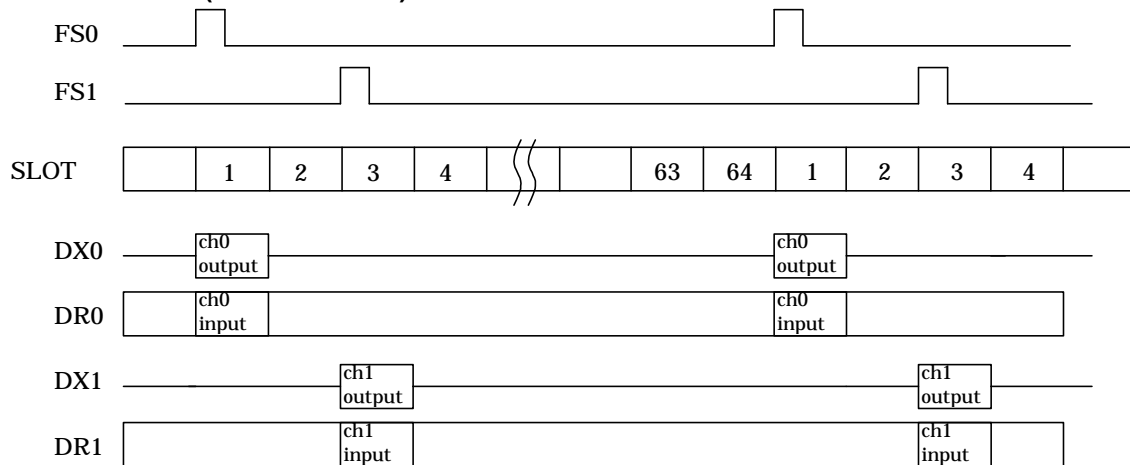

BCLK=64kHz(LF) (FS0 and FS1 at the same timing, First FS = FS0)

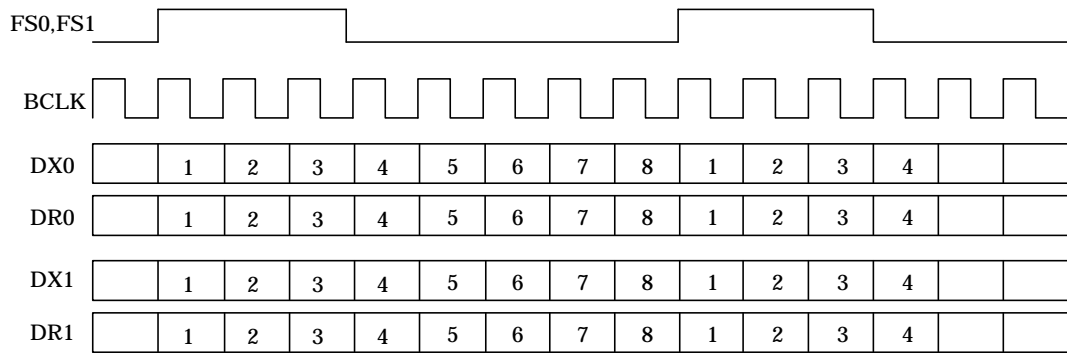

BCLK=64kHz(LF) (First FS = FS0)

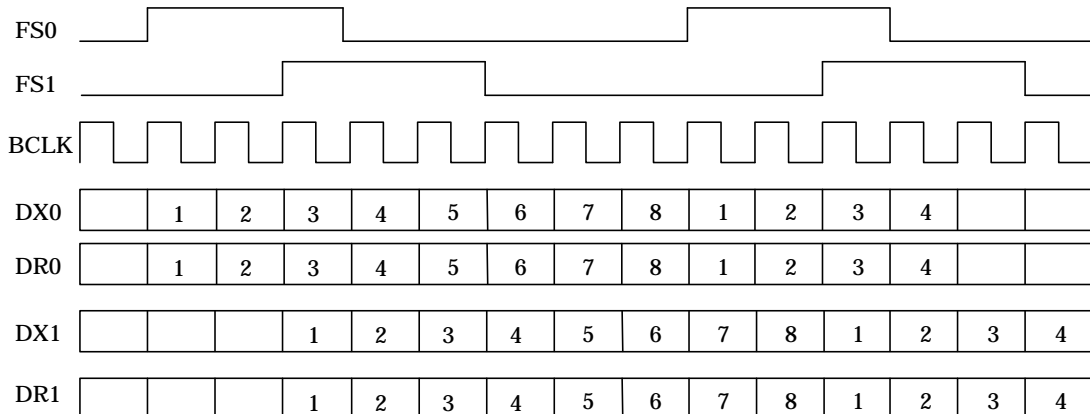

GCI(General Circuit Interface)

Interface used for ISDN. This data format is as below.
 PCM data channel assignment for B1 and B2 is defined by SEL2B register.

CH0,1selection

SEL2B	CH0	CH1	Remarks
0	B1	B2	Reset
1	B2	B1	

Note: BCLK is twice the PCM data rate.
 BCLK is acceptable from 512kHz to 4096kHz.

INTERFACE TIMING

<2ch Multiplex>

PCM data of each channel is interfaced through DR0/DX0 pin in 8bits format.
 They are accommodated in 1 frame(125us) which synchronizes with FS0.

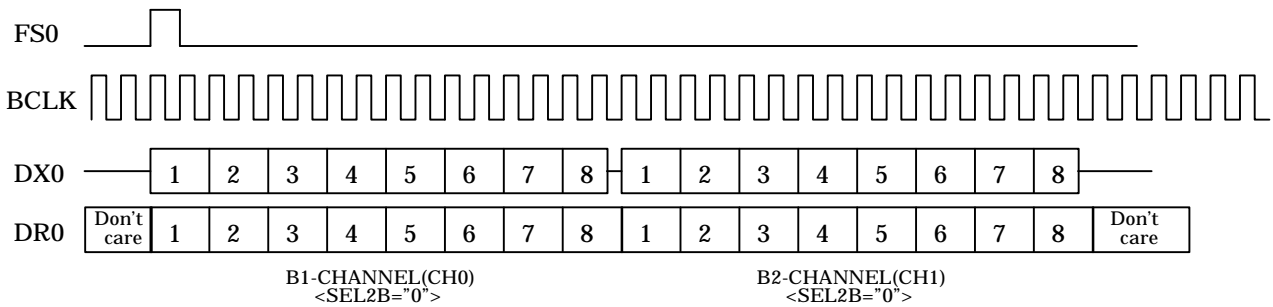

<Non Multiplex>

Not supported.

IDL(Interchip Digital Link)

Interface used for ISDN. This data format is as below.
 PCM data channel assignment for B1 and B2 channel is defined by SEL2B register.

CH0,1selection

SEL2B	CH0	CH1	Remarks
0	B1	B2	Reset
1	B2	B1	

Note: BCLK is same as the PCM data rate.
 BCLK is acceptable from 256kHz to 4096kHz.

INTERFACE TIMING

<2ch Multiplex>

PCM data of each channel is interfaced through DR0/DX0 pin in 8bits format.
 They are accommodated in 1 frame(125us) which synchronizes with FS0.

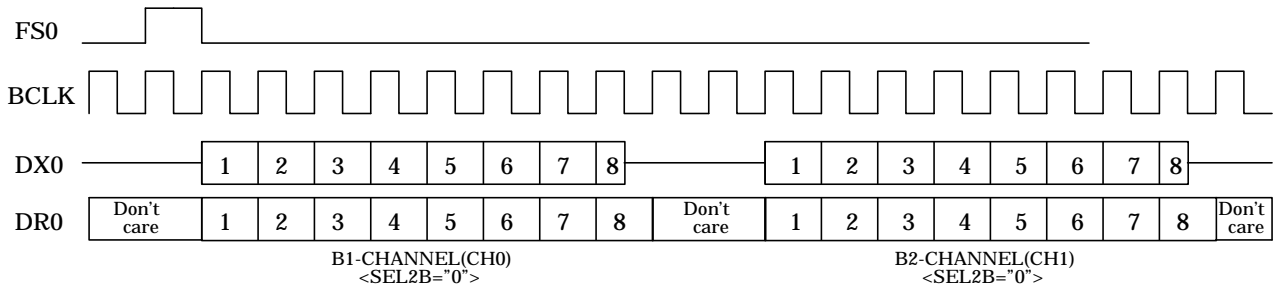

<Non Multiplex>

Not supported.

RESET

POWER ON RESET

AK2305 automatically generates the internal reset pulse at the time of power on. Then all circuits are reset and internal registers are initialized.

After reset operation, CODEC CH0/CH1 circuits start to be initialized. It takes 150ms(typ.), 330ms(max) from power on to completion of initialization.

*)Output pins remain Hi-Z during the period in which the internal reset pulse is high(See page 5).
The period of the reset pulse is about 20ms(typ), 200ms(max).

POWER-UP TIME FOR POWER ON RESET

When power-up time is no longer than 50ms(=5tau:tau is time constant), Power On Reset works normally.

When the time is longer than 50ms, Power On Reset is not available and no internal registers are initialized. All registers must be written.

RECOMMENDED START UP PROCEDURE

The following start up procedure is recommended when AK2305 is going to power up.

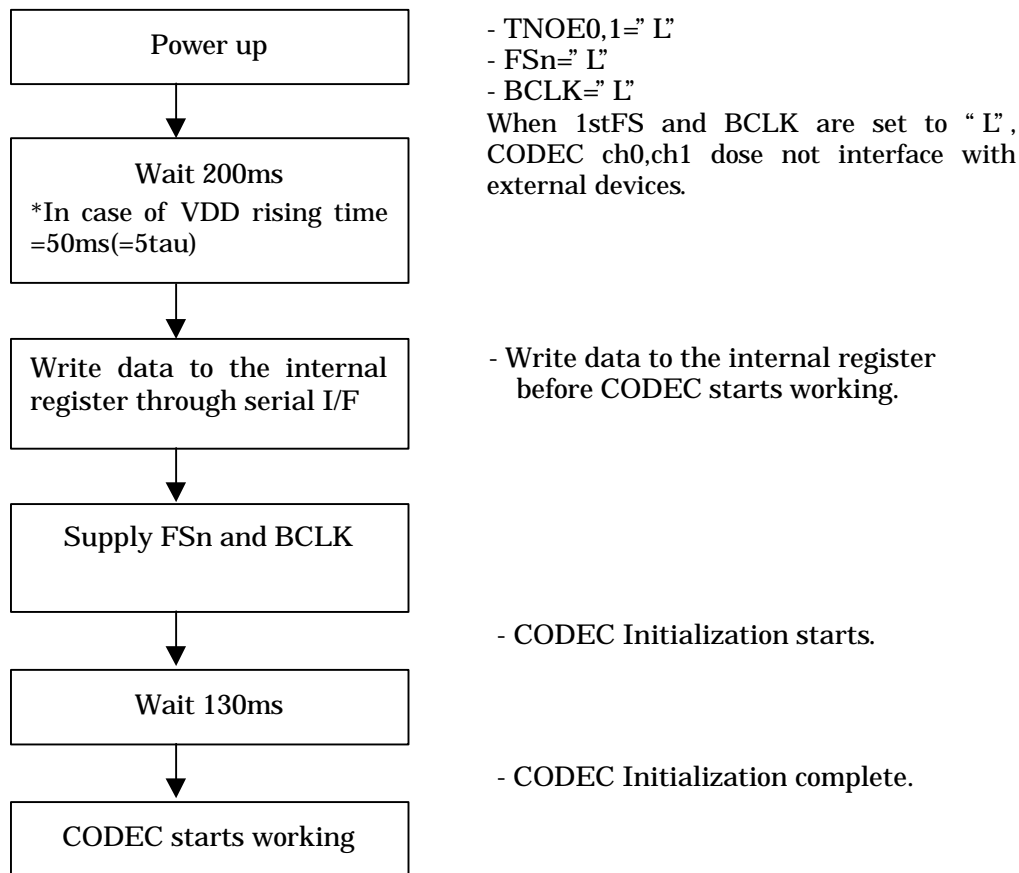

POWER DOWN

Power consumption is reduced in power down mode.

In the power down mode, supply of current for analog circuits and clock for digital circuits, is stopped, and relating circuits are halted.

There are two power down modes.

- **Power down for all circuits**
- **Power down by block**

* In the power down mode, output pins of corresponded blocks turn to Hi-Z.(See page 4)

POWER DOWN MODE SETTING

Mode	Circuits	Pin/Registers		Operation for "0"/"1"	Note
All circuits	All	Pin	PD	"0" : Normal "1" : Power down	- Registers are not reset. - Serial I/F is available. - No need to supply FS _n (n=0,1),BCLK.
Block	CODEC CH0	Registers	PDCH0	"0" : Normal "1" : Power down	- Keep supplying first FS, even when CODEC CH _{0,1} are in power down mode (see page8). - Even when CODEC CH _n (n=0,1) is in power down mode, the functions below are available: (1) AMPT _n (n=0,1) Input/Output (2) TONEGEN _{0,1} Output From VRX _n (n=0,1), TNOUT - Even when all these blocks are in power down mode; AMPT _{0/1} , VR _{0/1R} , AMPR _{0/1} , VRTN, TONEGEN _{0/1} , BGREF, Serial IF, PLL operate normally at all the time.
	CODEC CH1		PDCH1		
	DTMF Receiver0		PDDT0		
	DTMF Receiver1		PDDT1		

Note) Initial value of PDCH_n, PDDT_n(n=0,1) are "0".

CANCELLATION OF POWER DOWN : CODEC

When power down mode for CODEC CH_{0/CH1} is cancelled, CODEC starts to be initialized.

It takes 130mS(typ.).

POWER DOWN MODE SETTING and POWER DOWN BLOCK

POWER DOWN BLOCK	ALL BLOCK	CODEC CH0	CODEC CH1	CODEC CH0&1	DTMFR0	DTMFR1	CODEC CH0, DTMFR0	CODEC CH1, DTMFR1
PIN REGISTER	PD	PDCH0	PDCH1	PDCH0 PDCH1	PDDT0	PDDT1	PDCH0 PDDT0	PDCH1 PDDT1
Channel 0	AMPT0	OFF					OFF	
	VR0T	OFF	OFF		OFF		OFF	
	AAF0	OFF	OFF		OFF		OFF	
	CODEC CH0	OFF	OFF		OFF		OFF	
	SMF0	OFF	OFF		OFF		OFF	
	VR0R	OFF						
	AMPR0	OFF						
Channel 1	AMPT1	OFF						OFF
	VR1T	OFF		OFF	OFF			OFF
	AAF1	OFF		OFF	OFF			OFF
	CODEC CH1	OFF		OFF	OFF			OFF
	SMF1	OFF		OFF	OFF			OFF
	VR1R	OFF						
	AMPR1	OFF						
PCM I/F	OFF			OFF				
TONEGEN 0	OFF							
TONEGEN 1	OFF							
VRTN	OFF							
DTMFR 0	OFF				OFF		OFF	
DTMFR 1	OFF					OFF	OFF	
PLL	OFF							
BGREF	OFF							
SERIAL I/F								

MUTE

PIN CONTROL

The output on each channel can be muted independently by pin control.

MUTE _n (n=0,1)	Operation	DX _n pin (n=0,1)	VRX _n pin (n=0,1)	Remarks
0	Normal	PCM data output	CODEC analog output	
1	Mute	High-Impedance	AGND*	*)TONE circuits are available even if the mute operates.

REGISTER CONTROL

The output on each channel can be muted independently by register control.

MTDX _n (n=0,1)	Operation	DX _n pin (n=0,1)	VRX _n pin (n=0,1)	Remarks
0	Normal	PCM data output	CODEC analog output* (MUTE _{0,1} pin="0")	Reset
1	Mute	High-Impedance		

*) MUTE_n is given priority over MTDX_n. Therefore, for instance, even when MTDX_n is "1," output of VRX_n is AGND if MUTE_n="1."

<Example>

CH0 muted (MUTE₀="1," MUTE₁="0," MTDX_{0,1}="0" : GCI mode)

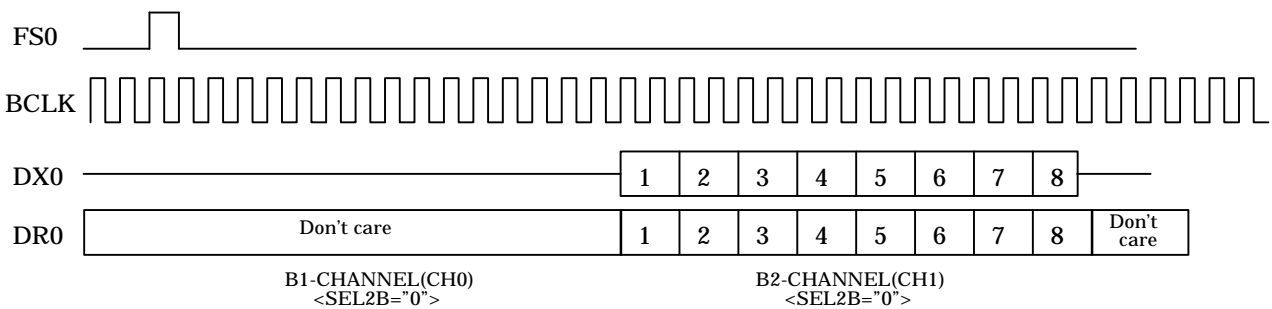

VRX₀ : CODEC CH0 analog output is always at AGND level.
TONEGEN_{0,1} output can be controlled by TNOE_{0,1} pin.

VRX₁ : CODEC CH1 analog output is the signal converted from the PCM data of CH1 input through DR0 pin.
TONEGEN_{0,1} output can be controlled by TNOE_{0,1} pin.

GAIN ADJUSTMENT

Analog input/output gain can be adjusted at the range from 0 to -12dB (3dB/step*5steps) by register.

VR register

VRnT2 VRnR2 VRTN2	VRnT1 VRnR1 VRTN1	VRnT0 VRnR0 VRTN0	Gain	Remarks
0	0	0	0 dB	Reset
0	0	1	-3 dB	
0	1	0	-6 dB	
0	1	1	-9 dB	
1	-	-	-12 dB	

*) This table is applicable to VR0T, VR0R, VR1T, VR1R ,and VRTN registers.

DTMF RECEIVER

This circuit detects and decodes the DTMF signal and outputs the 4bits code.
See the following table.

Output code table (n=0,1)

Low Tone [Hz]	High Tone [Hz]	KEY	DTO n3	DTO n2	DTO n1	DTO n0
697	1209	1	0	0	0	1
	1336	2	0	0	1	0
	1477	3	0	0	1	1
770	1209	4	0	1	0	0
	1336	5	0	1	0	1
	1477	6	0	1	1	0
852	1209	7	0	1	1	1
	1336	8	1	0	0	0
	1477	9	1	0	0	1
941	1336	0	1	0	1	0
	1209	*	1	0	1	1
	1477	#	1	1	0	0
697	1633	A	1	1	0	1
770	1633	B	1	1	1	0
852	1633	C	1	1	1	1
941	1633	D	0	0	0	0

DECODED OUTPUT

Decoded DTMF signals are output at DTO00-03,10-13 pins through tri-state buffers.
The outputs are enabled by DTOE pin.

DTOE Input	DTO00-03, DTO10-13 Output
0	Hi-Impedance
1	Decoded Output

GUARD TIME SETTING

Input Signal Available Time(t_{REC}) and Inter Digit Pause Time(t_{ID}) can be settled by adjusting Guard Time as follows. Guard Time is adjusted by GTPn, GTAn(n=0-3.)

$$\frac{\text{Input Signal Available Time}(t_{REC})}{\text{Inter Digit Pause Time}(t_{ID})} = \frac{\text{Detecting Signal Time}(t_{DP})}{\text{Detecting Signal-stop Time}(t_{DA})} + \frac{\text{Guard Time}(t_{GTP})}{\text{Guard Time}(t_{GTA})}$$

Range of adjusting Guard Time(t_{GTP} , t_{GTA})	1ms - 121 ms
Step of adjusting Guard Time(t_{GTP} , t_{GTA})	8ms

Regarding the relation between GTPn / GTAn(n=0-3) and Guard Time, see the next page.
Also the relation between Input Signal Available Time(t_{REC}) and Inter Digit Pause Time(t_{ID}) is shown.

Relation between GTPn(n=0- 3) Register and GUARD TIME(t_{GTP})/Input Signal Available Time(t_{REC})

GTP Register				tGTP[ms] typ	tREC[ms]=tGTP+tDP			
3	2	1	0		min	typ	max	
0	0	0	0	1	6	12	15	
0	0	0	1	9	14	20	23	
0	0	1	0	17	22	28	31	
0	0	1	1	25	30	36	39	
0	1	0	0	33	38	44	47	← tGTP default
0	1	0	1	41	46	52	55	
0	1	1	0	49	54	60	63	
0	1	1	1	57	62	68	71	
1	0	0	0	65	70	76	79	
1	0	0	1	73	78	84	87	
1	0	1	0	81	86	92	95	
1	0	1	1	89	94	100	103	
1	1	0	0	97	102	108	111	
1	1	0	1	105	110	116	119	
1	1	1	0	113	118	124	127	
1	1	1	1	121	126	132	135	

tDP[ms]		
min	typ	max
5	11	14

Relation between GTAn(n=0- 3) Register and GUARD TIME(t_{GTA})/Inter Digit Pause Time(t_{ID})

GTA Register				tGTA[ms] typ	tID[ms]=tGTA+tDA			
3	2	1	0		min	typ	max	
0	0	0	0	1	1.5	5	9.5	
0	0	0	1	9	9.5	13	17.5	
0	0	1	0	17	17.5	21	25.5	← tGTA default
0	0	1	1	25	25.5	29	33.5	
0	1	0	0	33	33.5	37	41.5	
0	1	0	1	41	41.5	45	49.5	
0	1	1	0	49	49.5	53	57.5	
0	1	1	1	57	57.5	61	65.5	
1	0	0	0	65	65.5	69	73.5	
1	0	0	1	73	73.5	77	81.5	
1	0	1	0	81	81.5	85	89.5	
1	0	1	1	89	89.5	93	97.5	
1	1	0	0	97	97.5	101	105.5	
1	1	0	1	105	105.5	109	113.5	
1	1	1	0	113	113.5	117	121.5	
1	1	1	1	121	121.5	125	129.5	

tDA[ms]		
min	typ	max
0.5	4	8.5

NOTE

tGTA in tables above are typical value. Regard the margin of ±1ms.

tone GENERATOR

Generates two kinds of tone, 400Hz and 1300Hz.
One of them is selected by TMDn register.

SELECTION OF TONE

Selects 1 tone from 400Hz/1300Hz by TMDn register.

Tone selection register

TMDn	Tone frequency	Remarks
0	400Hz	Reset
1	1300Hz	

(n=0,1)

SELECTION OF OUTPUT PIN

VRX0, VRX1, TNOOUT is available for Tone output pin by S1-S9 switch.
S1-S9 switch is controlled by each register.

Tone output by switch controlling

Output circuits	VRX0	VRX1	TNOOUT	Register setting	Remarks
toneGEN0	S1	S4	S7	"0" : OFF "1" : ON	All "0" when reset
toneGEN1	S2	S5	S8		
AUX	S3	S6	S9		

tone OUTPUT ENABLE

Inputting "1" to TNOEn, defined tone is output.

Tone Output Enable

TONEn	Output States
0	AGND
1	Tone

AUX INPUT

Input signal from external CPU/Tone generators.
Signals are output on VRXn, TNOOUT via VRnR, VRTN.
Output signals are switched onto each pin by S3, S6, and S9 which are controlled by registers.
(See "SELECTION OF OUTPUT PIN" above.)

Must input with an external cap(>0.1uF.)
Input impedance is 200kΩ±25%.

SERIAL INTERFACE

The internal registers can be read/written with SCLK, DATA, and \overline{CS} pins.

1word consists of 14bits. The first 2bits are the instruction code which specifies read/write. The following 3bits specify the address. The rest of 8bits are for setting registers.

B13	B12	B11	B10	B9	B8	B7	B6	B5	B4	B3	B2	B1	B0
I1	I0	A2	A1	A0	*	D7	D6	D5	D4	D3	D2	D1	D0
Instruc-tion code (2bit)		Address (3bit)			*	Data for setting internal registers (8bit)							

*)Dummy bit for adjusting the I/O timing when reading data.

INSTRUCTION CODE

I1	I0	Read/Write
1	0	Read
1	1	Write
Other codes		No action

SCLK and WRITE / READ

- (1) Input data are loaded into the internal shift register at the rising edge of SCLK.
- (2) The rising edge of SCLK is counted after the falling edge of \overline{CS} .
- (3) When \overline{CS} is "L" and more than 14 SCLK pulses:
[WRITE] Data are loaded into the internal register at the rising edge of the SCLK 14th pulse.
[READ] DATA pin is switched to an input pin at the falling edge of the SCLK 14th pulse.

\overline{CS} and WRITE / READ CANCELLATION

- (1) WRITE is cancelled when \overline{CS} goes up before the rising edge of the SCLK 14th pulse.
- (2) READ is cancelled when \overline{CS} goes up before the falling edge of the SCLK 14th pulse.

SERIAL WRITE / READ (SERIAL ACCESS)

- (1) \overline{CS} must go up to "H" before the next access in successive access.
- (2) When the next access is going to be done , if \overline{CS} remains to be "L", successive access can not be done.

WRITE

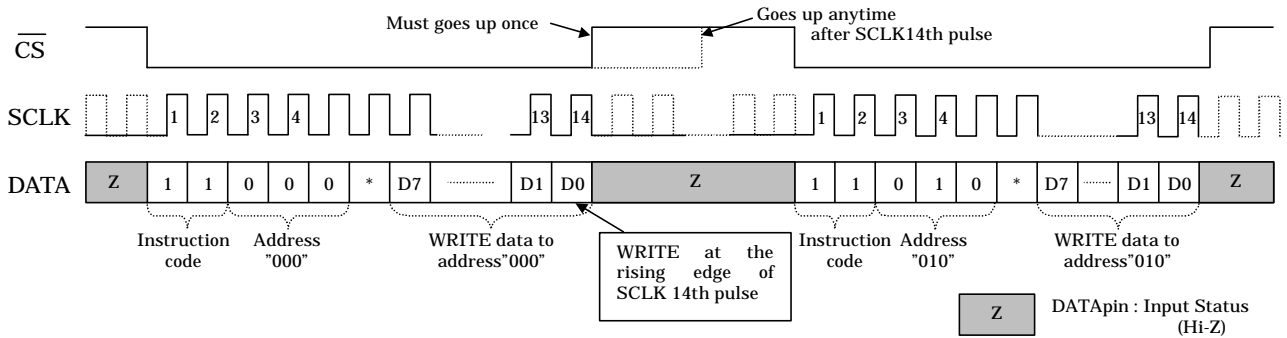

WRITE - CANCELLATION -

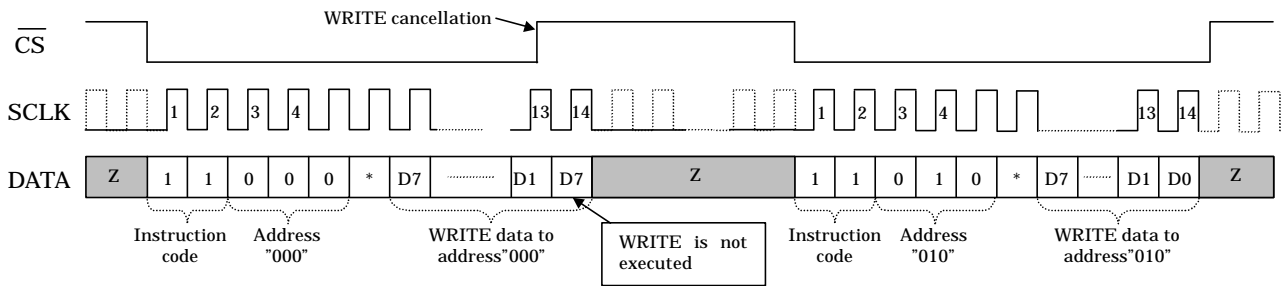

WRITE - SERIAL ACCESS -

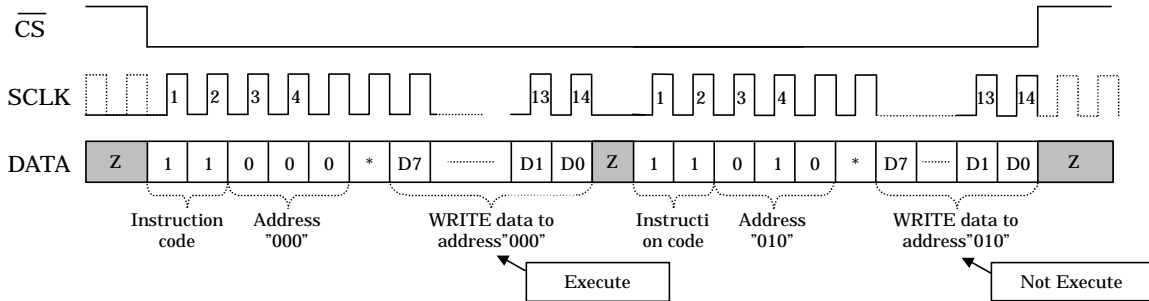

READ

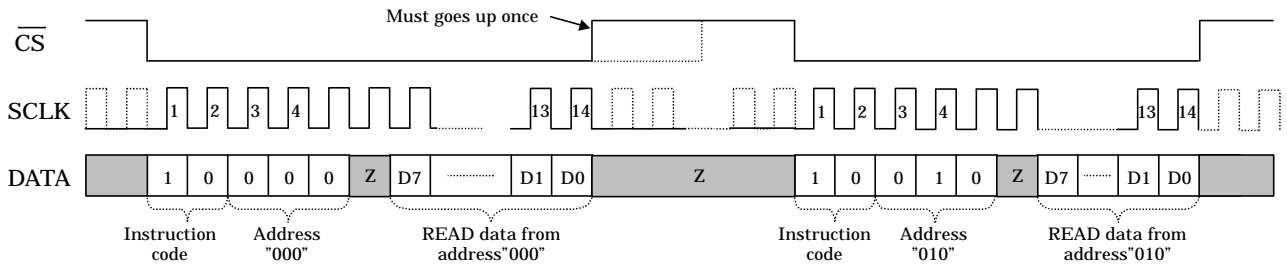

READ - OUTPUT PERIOD OF DATA PIN -

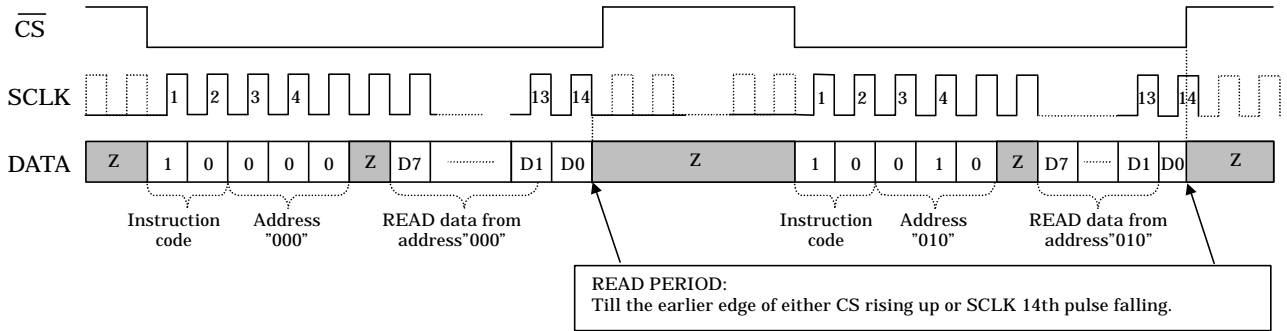

READ - SERIAL ACCESS -

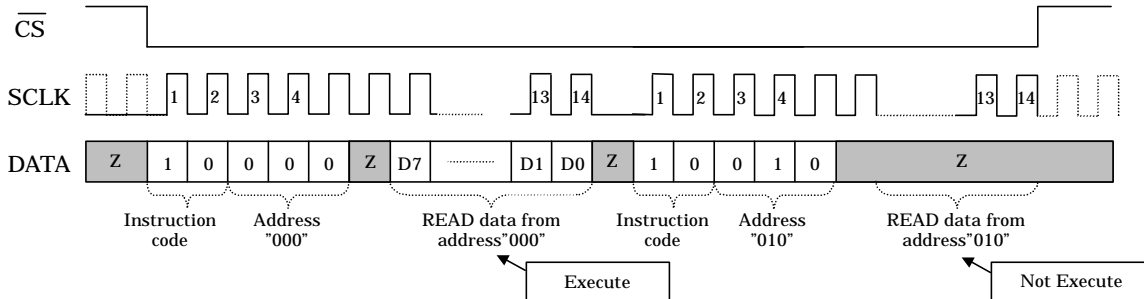

DISCORD OF INSTRUCTION CODE

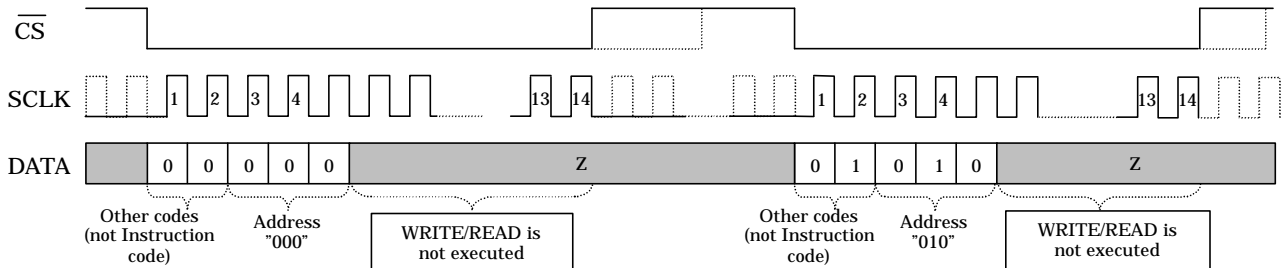

REGISTER

REGISTER MAP

Bit 11	Bit 10	Bit 9	Bit 8	Bit 7	Bit 6	Bit 5	Bit 4	Bit 3	Bit 2	Bit 1	Bit 0
A2	A1	A0	*	D7	D6	D5	D4	D3	D2	D1	D0
0	0	0	*	-	VR0T2	VR0T1	VR0T0	-	VR0R2	VR0R1	VR0R0
0	0	1	*	-	VR1T2	VR1T1	VR1T0	-	VR1R2	VR1R1	VR1R0
0	1	0	*	-	S9	S8	S7	-	VRTN2	VRTN1	VRTN0
0	1	1	*	-	S6	S5	S4	-	S3	S2	S1
1	0	0	*	PCMIF1	PCMIF0	SEL2B	1stFS	PDDT1	PDDT0	PDCH1	PDCH0
1	0	1	*	-	-	-	ALAWN	MTDX1	MTDX0	TMD1	TMD0
1	1	0	*	GTA3	GTA2	GTA1	GTA0	GTP3	GTP2	GTP1	GTP0

*) Dummy Bit

Note) All registers are available for write/read.

INITIALIZATION OF REGISTERS

Only at POWER ON RESET, registers are initialized.

When POWER ON RESET is not used, all registers should be set through a serial interface.

FUNCTION OF REGISTER

Address	Bit	Name	Default	Function	Refer to	
000	0	VR0R0	0	Receive gain adjustment on ch0 0 to -12dB by 3dBstep 000: 0dB 1xx: -12dB	18	
	1	VR0R1	0			
	2	VR0R2	0	000: 0dB 1xx: -12dB		
	3	-	0	Not used		
	4	VR0T0	0	Transmit gain adjustment on ch0 0 to -12dB by 3dBstep 000: 0dB 1xx: -12dB		
	5	VR0T1	0			
	6	VR0T2	0	000: 0dB 1xx: -12dB		
	7	-	0	Not used		
001	0	VR1R0	0	Receive gain adjustment on ch1 0 to -12dB by 3dBstep 000: 0dB 1xx: -12dB	18	
	1	VR1R1	0			
	2	VR1R2	0	000: 0dB 1xx: -12dB		
	3	-	0	Not used		
	4	VR1T0	0	Transmit gain adjustment on ch1 0 to -12dB by 3dBstep 000: 0dB 1xx: -12dB		
	5	VR1T1	0			
	6	VR1T2	0	000: 0dB 1xx: -12dB		
	7	-	0	Not used		
010	0	VRTN0	0	Gain adjustment of tone output 0 to -12dB by 3dBstep 000: 0dB 1xx: -12dB	18	
	1	VRTN1	0			
	2	VRTN2	0	000: 0dB 1xx: -12dB		
	3	-	0	Not used		
	4	S7	0	Switch regulation for tone output 0: Tone OFF 1: Tone ON	21	
	5	S8	0			
	6	S9	0	0: Tone OFF 1: Tone ON		
	7	-	0	Not used		
8	-	-	Dummy bit			
011	0	S1	0	Switch regulation for tone output 0: Tone OFF 1: Tone ON		21
	1	S2	0			
	2	S3	0	0: Tone OFF 1: Tone ON		
	3	-	0	Not used		
	4	S4	0	Switch regulation for tone output 0: Tone OFF 1: Tone ON		
	5	S5	0			
	6	S6	0	0: Tone OFF 1: Tone ON		
	7	-	0	Not used		
8	-	-	Dummy bit			

Address	Bit	Name	Default	Function	Refer to
100	0	PDCH0	0	CODEC ch0,1 Power down control 0: Power ON 1: Power OFF	15
	1	PDCH1	0		
	2	PDDT0	0	DTMF Receiver 0,1 Power down control 0: Power ON 1: Power OFF	
	3	PDDT1	0		
	4	1stFS	0	First FS select 0: FS0 1: FS1	9
	5	SEL2B	0	PCM data channel assignment 0: CH0->B1	12
	6	PCMIF0	0	PCM interface select Multiplex/Non Multiplex	9
	7	PCMIF1	0		
	8	-	-	Dummy bit	
101	0	TMD0	0	TONEGEN 0,1 tone frequency select 0: 400Hz 1: 1300Hz	21
	1	TMD1	0		
	2	MTDX0	0	PCM output(DX0,1pin) Mute 0: PCM OUT 1: PCM MUTE	17
	3	MTDX1	0		
	4	ALAWN	1	A-law/u-law select 0:A-law 1:u-law	8
	5	-	0	Not used	
	6	-	0		
	7	-	0		
8	-	-	Dummy bit		
110	0	GTP0	0	DTMF Receiver Guard Time t_{GTP} setting	20
	1	GTP1	0		
	2	GTP2	0		
	3	GTP3	0		
	4	GTA0	0	DTMF Receiver Guard Time t_{GTA} setting	20
	5	GTA1	0		
	6	GTA2	0		
	7	GTA3	0		
	8	-	-	Dummy bit	

ABSOLUTE MAXIMUM RATINGS

Parameter	Symbol	Min	Max	Units
Power Supply Voltages				
Digital Power Supply	DVDD	-0.3	6.5	V
Analog Power Supply	AVDD	-0.3	6.5	V
DVSS Voltage	DVSS	-0.1	0.1	V
Digital Input Voltage	VTD	-0.3	AVDD+0.3	V
Analog Input Voltage	VTA	-0.3	AVDD+0.3	V
Input current (except power supply pins)	IIN	-10	10	mA
Storage Temperature	Tstg	-55	125	°C

Note 1) All voltages with respect to ground. : AVSS=DVSS=0V

Warning: Exceeding absolute maximum ratings may cause permanent damage.

Normal operation is not guaranteed at these extremes.

RECOMMENDED OPERATING CONDITIONS

Parameter	Symbol	Min	Typ	Max	Units
Power Supplies ¹⁾					
Analog power supply	AVDD	4.75	5.0	5.25	V
Digital power supply	DVDD	4.75	5.0	AVDD	V
Ambient Operating Temperature	Ta	-40		85	°C
Frame Sync Frequency	FS0,FS1		8		kHz

Note 1) If DVDD is greater than AVDD, then IDD will increase

Note) All voltages reference to ground : AVSS=DVSS=0V

ELECTRICAL CHARACTERISTICS

Unless otherwise noted, guaranteed for AVDD=DVDD=+5V +/- 5%, Ta = -40 ~ +85 °C, FS0,FS1=8kHz.

DC Characteristics

Parameter	Symbol	Conditions	Min	Typ	Max	Units
Power Consumption	PDD1	PDCH0,1 PDDT0,1=0,0 All output unloaded		85	105	mW
BCLK=2048kHz	PDD2	PDCH0,1 PDDT0,1=1,0 All output unloaded		60	78.8	
Output High Voltage1 (CMOS level)	VOH1	IOH=-1.6mA Except for DTOn0-n3(n=0,1)	0.8VDD			V
Output Low Voltage1 (CMOS level)	VOL1	IOL=1.6mA Except for DTOn0-n3(n=0,1)			0.4	V
Input High Voltage (TTL level)	VIH		2.0			V
Input Low Voltage (TTL level)	VIL				0.8	V
Input Leakage Current	Ii		-10		+10	uA
Input Capacitance	Ci				5	pF
Output Leakage Current	Io	Tri-state mode	-10		+10	uA

CODEC**Absolute Gain**

Parameter	Conditions	Min	Typ	Max	Units
Analog Input Level	Input: 0dBm0@1020Hz		0.849		Vrms
Absolute Transmit Gain		-0.6	-	0.6	dB
Analog Output Level	Input: 0dBm0@1020Hz		0.849		Vrms
Absolute Receive Gain		-0.6	-	0.6	dB
Maximum Overload Level	3.14dBm0		1.219		Vrms

Gain Tracking

Parameter	Conditions	Min	Typ	Max	Units
Transmit Gain Tracking Error	Reference Level: -55dBm0 ~ -50dBm0	-1.2	-	1.2	dB
	-10dBm0 -50dBm0 ~ -40dBm0	-0.4	-	0.4	
	1020Hz Tone -40dBm0 ~ 3dBm0	-0.2	-	0.2	
Receive Gain Tracking Error	Reference Level: -55dBm0 ~ -50dBm0	-1.2	-	1.2	dB
	-10dBm0 -50dBm0 ~ -40dBm0	-0.4	-	0.4	
	1020Hz Tone -40dBm0 ~ 3dBm0	-0.2	-	0.2	

Frequency Response

Parameter	Conditions	Min	Typ	Max	Units	
Transmit Frequency Response	Relative to: 0dBm0@1020Hz	0.05kHz	-	-	-30	dB
		0.06kHz	-	-	-26	
		0.2kHz	-1.8	-	0	
		0.3 ~ 3.0kHz	-0.15	-	0.15	
		3.4kHz	-0.8	-	0	
		4.0kHz	-	-	-14	
Receive Frequency Response	Relative to: 0dBm0@1020Hz	0 ~ 3.0kHz	-0.15	-	0.15	dB
		3.4kHz	-0.8	-	0	
		4.0kHz	-	-	-14	

Distortion

Parameter	Conditions	Min	Typ	Max	Units	
Transmit Signal to Distortion	1020Hz Tone	-40dBm0 ~ -45dBm0	25	-	-	dB
		-30dBm0 ~ -40dBm0	30	-	-	
		0dBm0 ~ -30dBm0	36	-	-	
Receive Signal to Distortion	1020Hz Tone	-40dBm0 ~ -45dBm0	25	-	-	dB
		-30dBm0 ~ -40dBm0	30	-	-	
		0dBm0 ~ -30dBm0	36	-	-	
Single Frequency Distortion Transmit		-	-	-46	dB	
Single Frequency Distortion Receive		-	-	-46	dB	
Intermodulation Distortion	-6dBm@860Hz,1380Hz	-	-	-42	dB	

Note) C-message Weighted for u-Law, Psophometric Weighted for A-Law

Envelope delay Distortion

Parameter	Conditions	Min	Typ	Max	Units
Transmit Delay, Absolute	f =1600Hz	-	-	560	us
Transmit Delay, Relative Relative to f=1600Hz	f =500Hz ~600Hz	-	-	220	us
	f =600Hz ~1000Hz	-	-	145	
	f =1000Hz ~2600Hz	-	-	75	
	f =2600Hz ~2800Hz	-	-	105	
	f =2800Hz ~3000Hz	-	-	155	
Receive Delay, Absolute	f =1600Hz			450	us
Receive Delay, Relative Relative to f=1600Hz	f =500Hz ~1000Hz	-40	-	-	us
	f =1000Hz ~1600Hz	-30	-	-	
	f =1600Hz ~2600Hz	-	-	90	
	f =2600Hz ~2800Hz	-	-	125	
	f =2800Hz ~3000Hz	-	-	175	

Noise

Parameter	Conditions	Min	Typ	Max	Units	
Idle Channel Noise ¹⁾ A□D	u-law, C-message	-	5	10	dBrnC0	
	A-law, Psophometric	-	-85	-80	dBm0p	
Idle Channel Noise ²⁾ D□A	u-law, C-message	-	5	10	dBrnC0	
	A-law, Psophometric	-	-85	-80	dBm0p	
Noise, Single Frequency	VFXIN = 0 Vrms, DR = DX f=0 ~100kHz	-	-	-53	dBm0	
PSRR, Transmit	AVDD=DVDD=5V±100mVop f=0 ~50kHz	40	-	-	dB	
PSRR, Receive	AVDD=DVDD=5V±100mVop f=0 ~50kHz	40	-	-	dB	
Spurious Out-of-Band Signal at VRX Output ³⁾	0dBm0, 0.3 ~3.4kHz PCM CODE	4.6 ~7.6kHz	-	-	-30	dB
		7.6 ~8.4kHz	-	-	-40	
		8.4 ~100kHz	-	-	-32	

Note 1) Analog Input = Analog Ground

Note 2) Digital Input(RD) = +0 Code

Note 3) Not tested in production. Parameters guaranteed by design.

Interchannel Crosstalk

Parameter	Conditions	Min	Typ	Max	Units
Transmit to Receive	0dBm0@VFXIN, Idle PCM code	-	-	-75	dB
Receive to Transmit	0dBm0 code level, VFXIN = 0 Vrms	-	-	-75	dB
Transmit to Transmit	0dBm0@VFXIN, Idle PCM code	-	-	-75	dB
Receive to Receive	0dBm0 code level, VFXIN = 0 Vrms	-	-	-75	dB

Intrachannel Crosstalk

Parameter	Conditions	Min	Typ	Max	Units
Transmit to Receive	0dBm0@VFXIN, Idle PCM code	-	-	-75	dB
Receive to Transmit	0dBm0 code level, VFXIN = 0 Vrms	-	-	-75	dB

Analog Interface Transmit Input Amplifier

Parameter	Conditions	Min	Typ	Max	Units
Input Leakage Current	0.6V < V < 4.2V	-100	-	+100	nA
Input Resistance		10	-	-	MΩ
Load Resistance		10	-	-	kΩ
Load Capacitance		-	-	50	pF
Output Voltage Swing		-	3.6	-	V _{p-p}
Output Impedance		-	-	10	Ω

Analog Interface Receive Output

Parameter	Conditions	Min	Typ	Max	Units
Output Voltage	0dBm0 PCM code	2.3	2.4	2.5	V
Load Resistance		10			kΩ
Load Capacitance				50	pF
Output Voltage Swing			3.6		V _{p-p}
Output Impedance				10	Ω

Analog Interface Receive Output Amplifier

Parameter	Conditions	Min	Typ	Max	Units
Input Leakage Current	0.6V < V < 4.2V	-100	-	+100	NA
Input Resistance		10	-	-	MΩ
Load Resistance		10	-	-	kΩ
Load Capacitance		-	-	50	pF
Output Voltage Swing		-	3.6	-	V _{p-p}
Output Impedance		-	-	10	Ω

Others**Volume VR0T,VR0R,VR1T,VR1R,VRTN**

Parameter	Pin	Conditions	Min	typ	max	Unit
Step margin		Relative to: 0dB	-0.5		+0.5	dB

AUX Input / Output

Parameter	Pin	Conditions	Min	typ	max	Unit
Input level	TNOUT	Input with 0.1uF: 3kHz VRTN=0dB			0	dBm
Input impedance	AUX		150	200	250	kΩ
Abcolute gain	VRX0,1 TNOUT	Input: 1kHz, -9dBm VRTN=0dB	-1	0	+1	dB
Frequency (Relative to output signal level when 1kHz input)	VRX0,1 TNOUT	Input: 10kHz, -9dBm VRTN=0dB	-1	0	+1	dB

Tone Generator

Parameters		Conditions	min	typ	Max	Units
Signal Frequency	400Hz		381	400	419	Hz
	1300Hz		1290	1300	1310	Hz
Transmit Signal Level			-11	-10	-9	dBm
Out of band noise level	4k-8kHz				P-20	dB
	8k-12kHz				P-40	dB
	Each 4kHz bandwidth higher than 12kHz				P-60	dB

Note) dBm = decibels above or below a reference power of 1mW into a 600Ω load.

P = output level of in band transmit signal.

DTMF Receiver

Parameter	Conditions	min	typ	Max	Units
Valid Input Signal Levels (each tone of composite signal)	Note2,3,6	-19		+1	dBm
Twist accept	Note3,6,8		±10		dB
Frequency Deviation accept	Note2,6			±1.5% ±2Hz	
Frequency Deviation Reject	Note2,6	±3.5%			
Third Tone Tolerance	Note1,2,6,7		-16		dB
Noise Tolerance	Note1,2,4,6,7		-12		dB
Dial Tone Tolerance	Note1,2,5,6,7		-17		dB
Input Impedance DTIN0, DTIN1		500			kΩ

Note1) Nominal DTMF frequencies are used.

Note2) Both tones of the composite signal have equal amplitudes.

Note3) Tone pair is deviated by ±1.5% ±2Hz.

Note4) Bandwidth limited to 3kHz Gaussian noise.

Note5) Precise dial tone frequencies of 350Hz±2% and 440Hz±2%.

Note6) For error rate of better than 1 in 10,000.

Note7) Referenced to minimum valid accept level.

Note8) Twist = high tone / low tone

Note) dBm = decibels above or below a reference power of 1mW into a 600Ω load.

DTMFReceiver

Parameters	Symbol	Condition	Min	Typ	Max	Units	Remarks
Tone Present Detection Time	t_{DP}		5	11	14	ms	
Tone Absent Detection Time	t_{DA}		0.5	4	8.5	ms	
Tone Duration Accept(*1)	t_{REC}		48	-	-	ms	
Tone Duration Reject(*1)	t_{REJ}		-	-	37	ms	
Interdigit Pause Accept(*1)	T_{ID}		26.5	-	-	ms	
Interdigit Pause Reject(*1)	t_{DO}		-	-	16.5	ms	
Propagation Delay(GT to DTOnx)	t_{PQ}	DTOE=5V,unloaded	-	-	12	us	
Propagation Delay(GT to STD)	t_{PSTD}	DTOE=5V,unloaded	-	-	14	us	
Output Data Set Up(DTOnx to STD)	t_{QSTD}	DTOE=5V,unloaded	-	-	2	us	
Output Data Enable(DTOE to DTO)	t_{PTE}	$R_L=10k, C_L=50pF$		10	40	ns	
Output Data Disable(DTOE to DTO)	t_{PTD}	$R_L=10k, C_L=50pF$		10	40	ns	

(*1) When GTPn, GPAn(n=0-3) are default. Adjustable by setting GTPn, GPAn(n=0-3).
See p.19 & p.20.

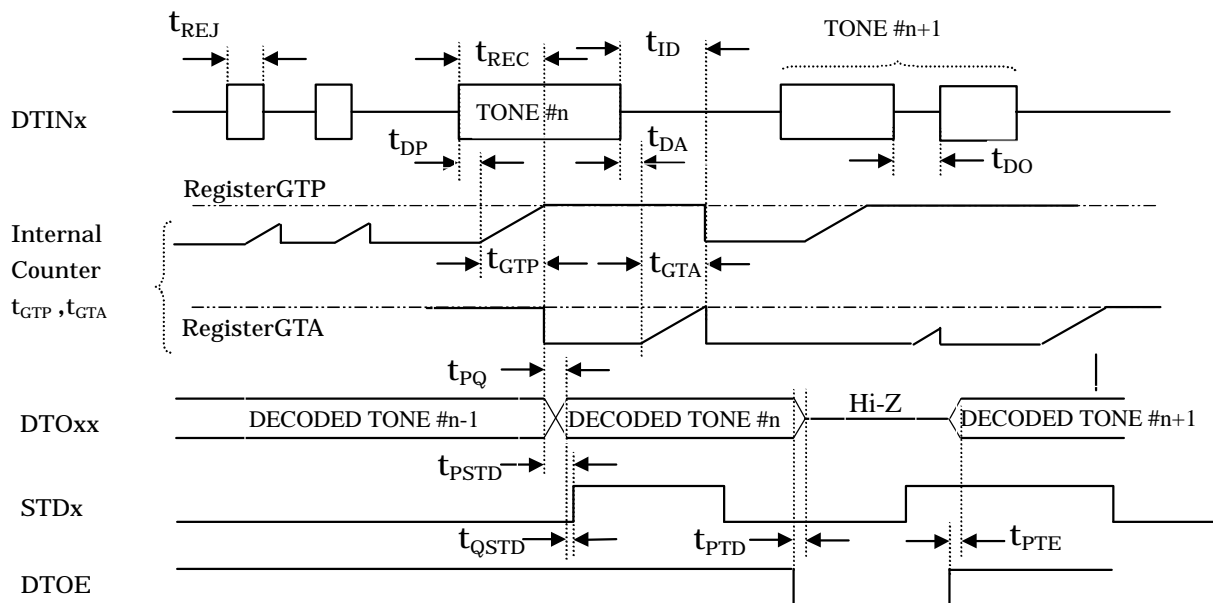

Figure 1 : DTMF Receiver Timing

Timing Specification

Unless otherwise noted, the specification applies for TA = -40 to +85°C, DVDD = AVDD = 5V±5%, DVSS = AVSS = 0V and FS0,FS1 = 8kHz. All timing parameters are measured at VOH = 2.0V and VOL = 0.7V.

Long Frame, Short Frame, GCI, IDL Timing

Parameter	Symbol	Min	Typ	Max	Unit	Ref fig
FS Frequency	1/t _{PF}	-	8	-	kHz	Fig.2 Fig.3 Fig.4 Fig.5
BCLK Frequency	1/t _{PB}	64		4096	kHz	
BCLK Pulse Width High	t _{WBH}	80			ns	
BCLK Pulse Width Low	t _{WBL}	80			ns	
Rising Time: (BCLK,FS0,FS1,DX0,DX1,DR0,DR1)	t _R			40	ns	
Falling Time: (BCLK,FS0,FS1,DX0,DX1,DR0,DR1)	t _F			40	ns	
Hold Time: BCLK Low to FS High	t _{HBF}	40			ns	
Setup Time: FS High to BCLK Low	t _{SFB}	70			ns	
Setup Time: DR to BCLK Low	t _{SDB}	40			ns	
Hold Time: BCLK Low to DR	t _{HBD}	40			ns	
Delay Time: BCLK High to DX valid (Note1)	t _{DBD}			60	ns	
Long Frame						
Hold Time: 2 nd period of BCLK Low to FS Low	t _{HBFL}	40			ns	Fig.2
Delay Time: FS or BCLK High, whichever is later, to DX valid (Note1)	t _{DZFL}			60	ns	
Delay Time: FS or BCLK Low, whichever is later, to DX High-Z (Note1)	t _{DZCL}	10		60	ns	
FS Pulse Width Low	t _{WFSL}	1			BCLK	
Short Frame						
Hold Time: BCLK Low to FS Low	t _{HBFS}	40			ns	Fig.3
Setup Time: FS Low to BCLK Low	t _{SFBS}	40			ns	
Delay Time: BCLK Low to DX High-Z (Note1)	t _{DZCS}	10		60	ns	
GCI						
BCLK Frequency	1/t _{PB}	512		4096	kHz	Fig.4
Delax Time: Second BCLK Low to DX High-Z	t _{DZCG}	10		60	ns	
Setup Time: DR to Second BCLK High	t _{SDBG}	40			ns	
Hold Time: Second BCLK High to DR	t _{HBDG}	40			ns	
IDL						
BCLK Frequency	1/t _{PB}	256		4096	kHz	Fig.5

Note1) When with 150pF cap, and two LSTTL operating.

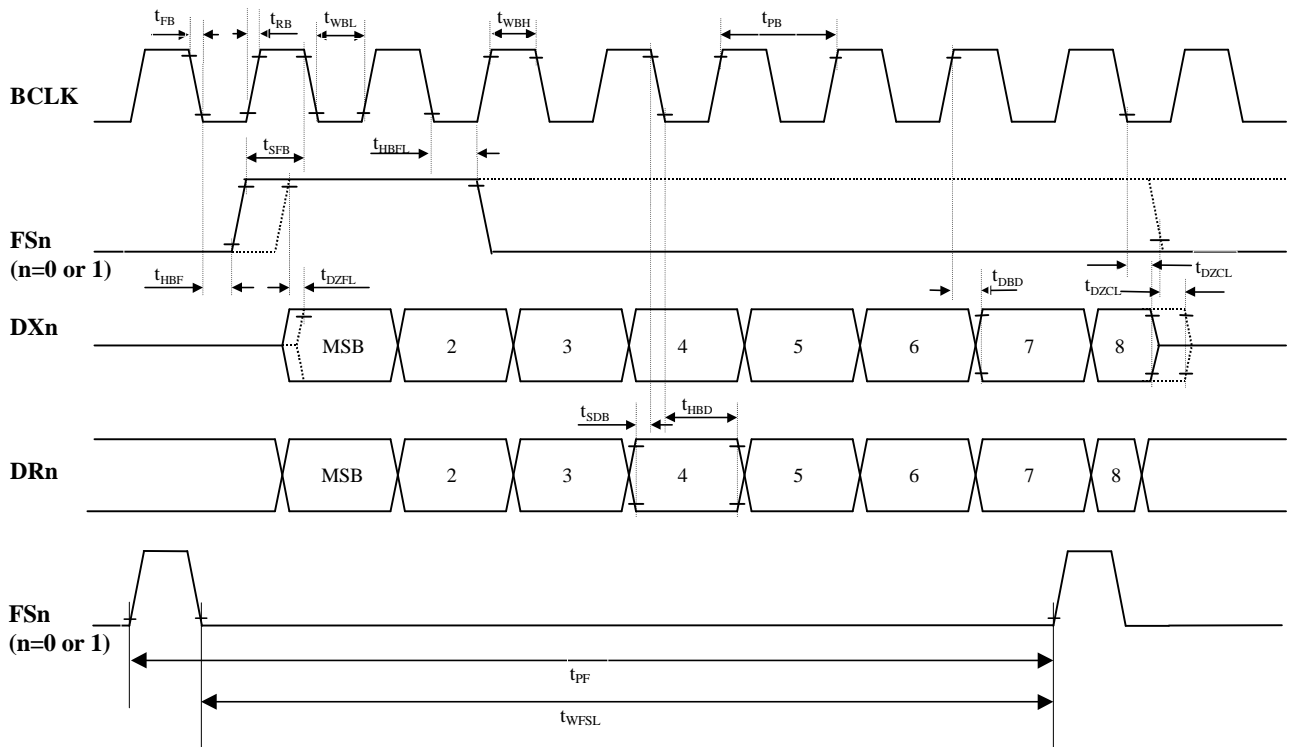

Figure2 : PCM Interface Timing < Long Frame >

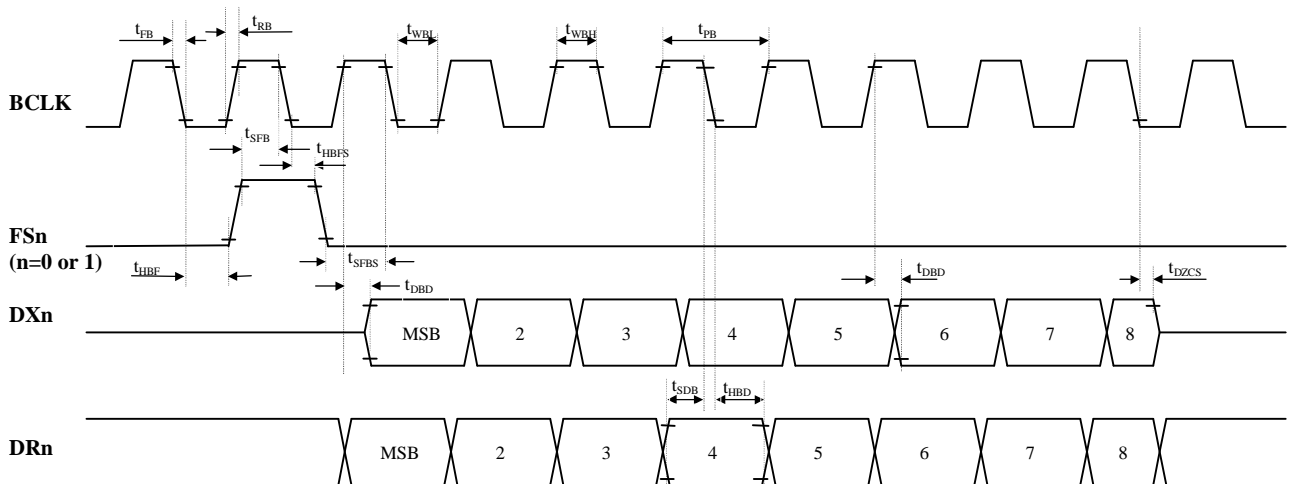

Figure3 : PCM Interface Timing < Short Frame >

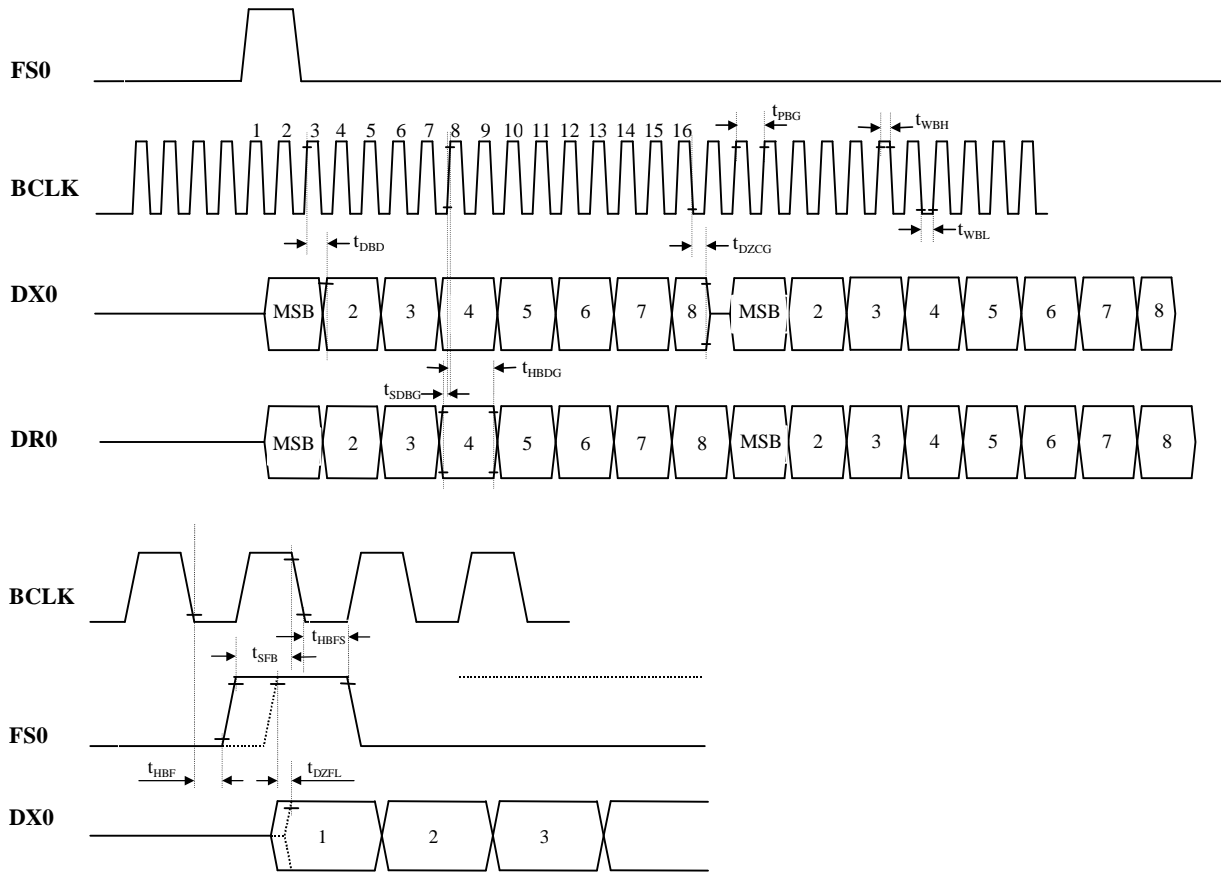

Figure4 : PCM Interface Timing < GCI >

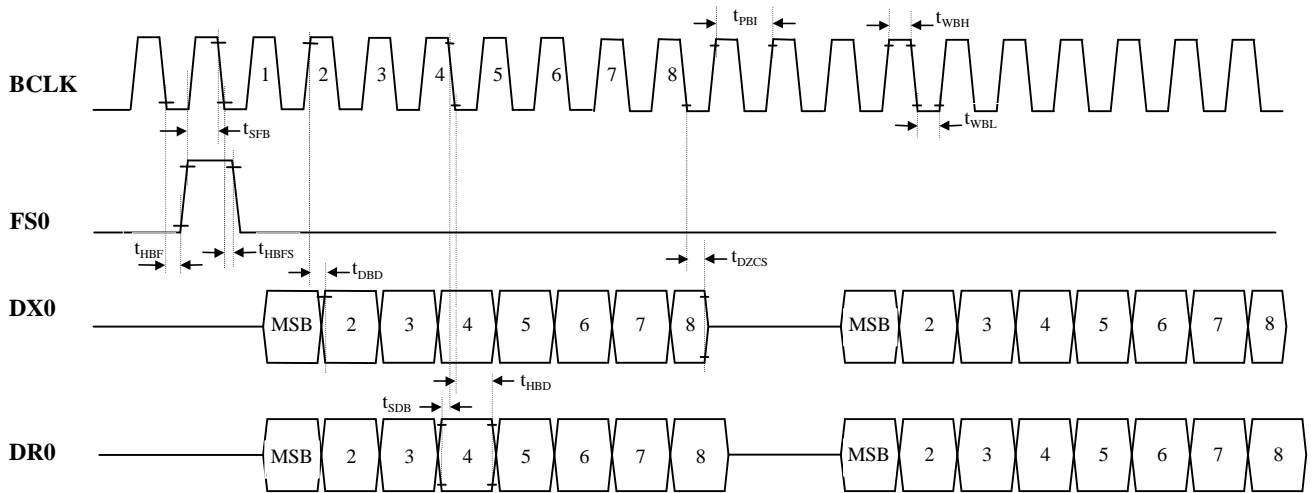

Figure5 : PCM Interface Timing < IDL >

Serial Interface Timing

Parameter	Symbol	Min	Typ	Max	Unit	Ref fig
SCLK Frequency	$1/t_{PSCLK}$			4	MHz	Fig.6
SCLK Pulse Width High	t_{WSH}	40			ns	
SCLK Pulse Width Low	t_{WSL}	40			ns	
\overline{CS} Pulse Width Low	t_{WCL}	14			SCLK	
Hold Time: SCLK High to \overline{CS} Low	t_{HCS}	80			ns	
Setup Time: \overline{CS} Low to SCLK High	t_{SCS}	40			ns	
Rising Time: \overline{CS} , SCLK	t_R			100	ns	
Falling Time: \overline{CS} , SCLK	t_F			100	ns	
W R I T E						
Setup Time: DATA to SCLK High	t_{SDC}	40			ns	Fig.6
Hold Time: SCLK High to DATA	t_{HDC}	40			ns	
Hold Time: SCLK Low to \overline{CS} High	t_{HCS2}	0			ns	
R E A D						
Delay Time: SCLK Low to DATA pin drive	t_{DVD}	0			ns	Fig.7
Delay Time: SCLK Low to DATA valid	t_{DDD}			60	ns	
Delay Time: SCLK Low to DATA High-Z	t_{DZSD}	0		60	ns	Fig.8
Delay Time: \overline{CS} High to DATA High-Z	t_{DZCD}	0		60	ns	
\overline{CS} Pulse Width High	t_{WCH}	40			ns	

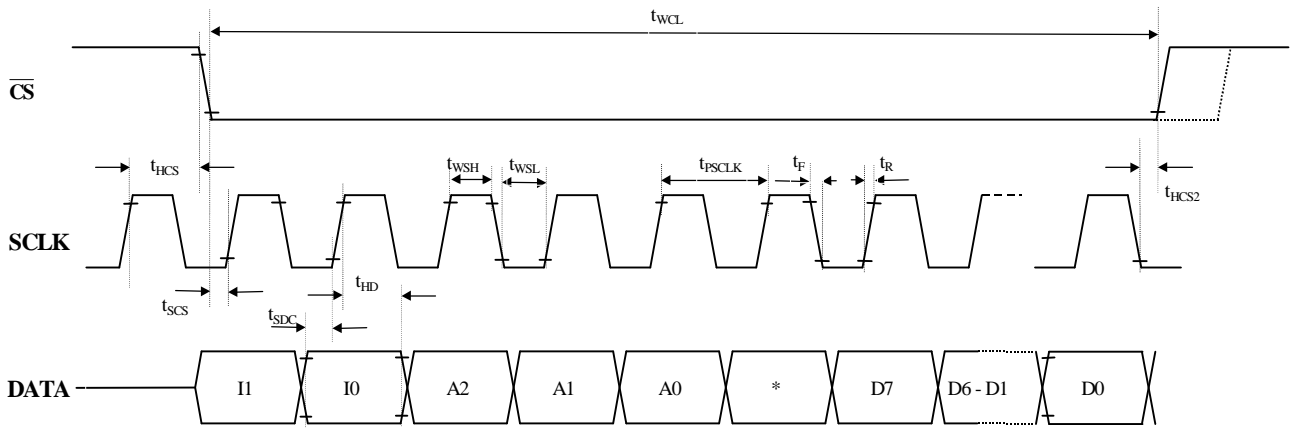

Figure6 : Serial Interface Timing < WRITE >

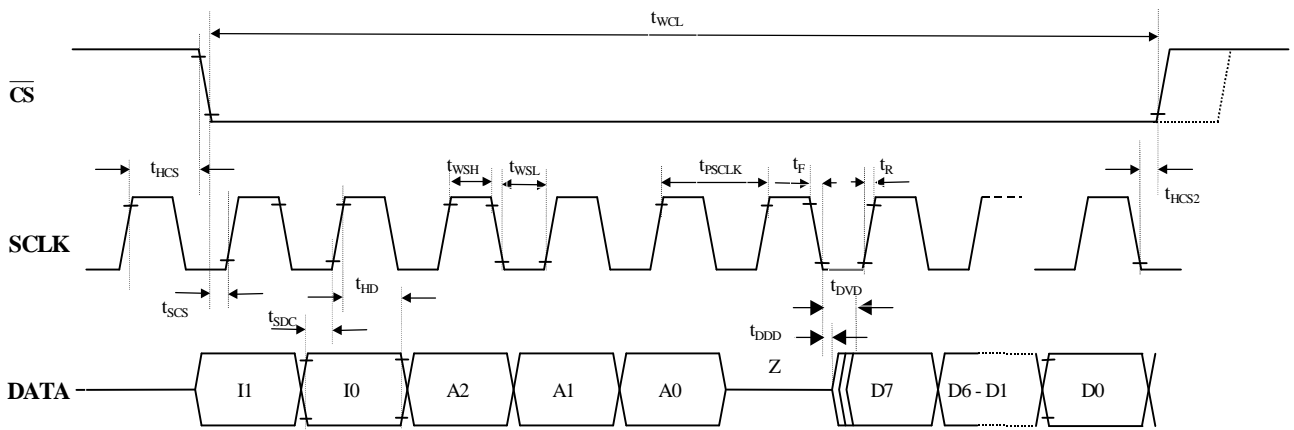

Figure7 : Serial Interface Timing < READ >

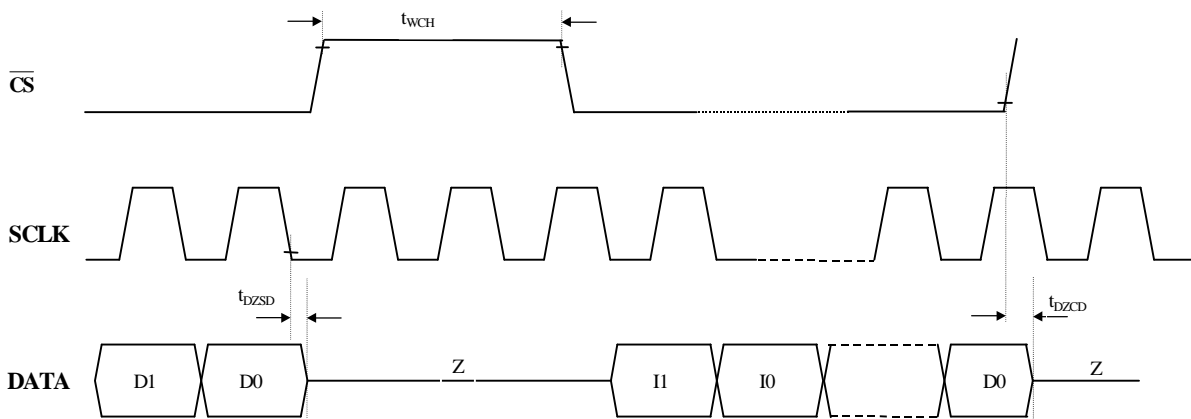
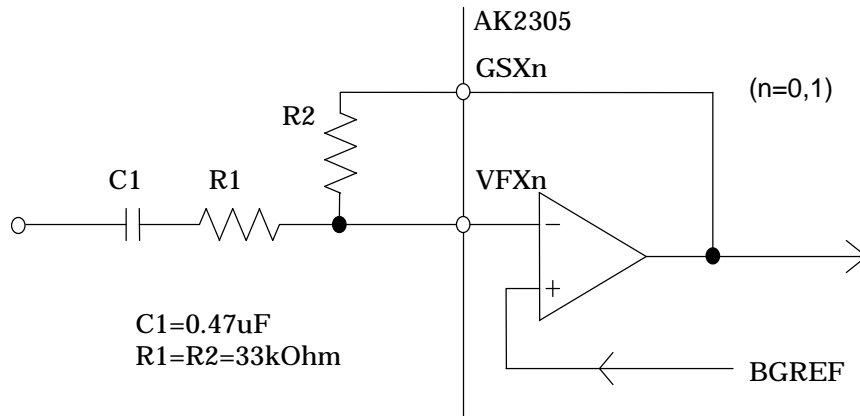

Figure8 : Serial Interface Timing < READ >

APPLICATION CIRCUIT EXAMPLE

Analog input circuit(AMPT0,1)

AK2305 has an op-amp at analog input of each channel. Each op-amp can be used as a gain adjustment. Op-amp can be used as an inverting amplifier. Feedback resistor must be 10kΩ or larger.



Analog output circuit(AMPR0,1)

AK2305 has an op-amp at analog input of each channel. Each op-amp can be used as a gain adjustment. Op-amp can be used as an inverting amplifier. Feedback resistor must be 10kΩ or larger.

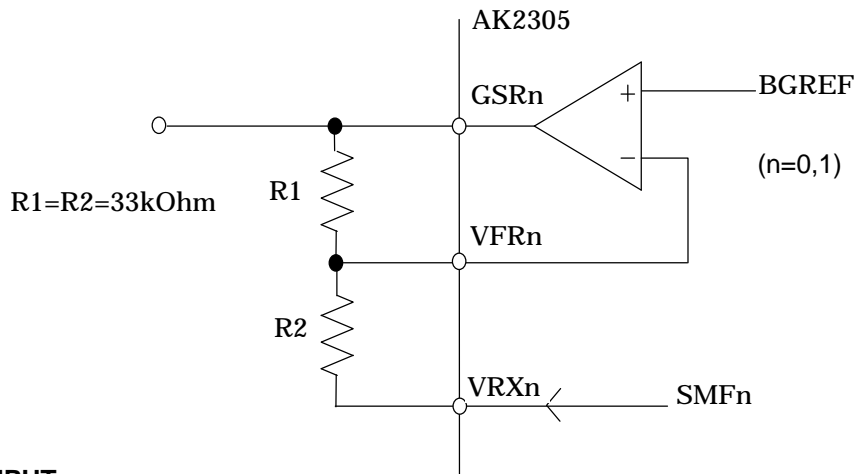

AUX INPUT

An external tone is input to AUX through an external capacitance of more than 0.1uF.

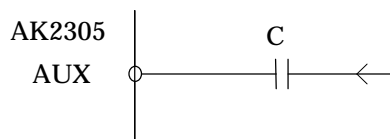

DTIN0, DTIN1 INPUT

There are the following 2 cases in case of that DTMF tone is input through DTIN0,DTIN1.

- (1)DTMF tone is output from AMPT0,AMPT1 included AK2305
Connect GSXn with DTINn directly.

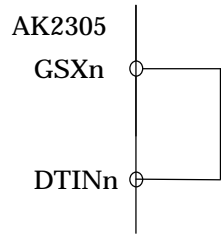

- (2) DTMF tone is output from an external amplifier
DTMF tone is input to DTIN0,DTIN1 through an external capacitance of more than 0.1uF.

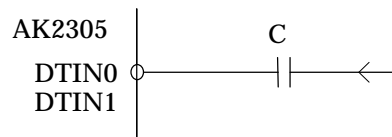

Analog ground stabilization capacitor

An external capacitor of more than 0.1uF should be connected between VREF and AVSS to stabilize analog ground (VREF).

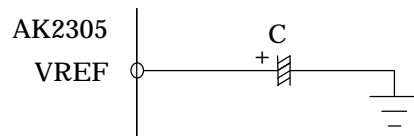

PLL Loop filter capacitor

An external capacitor of more than 0.22uF should be connected between LPC and AVSS.

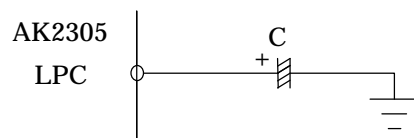

Power Supply

To attenuate the power supply noise, connect capacitors between AVDD and AVSS, and DVDD and DVSS, as shown below.

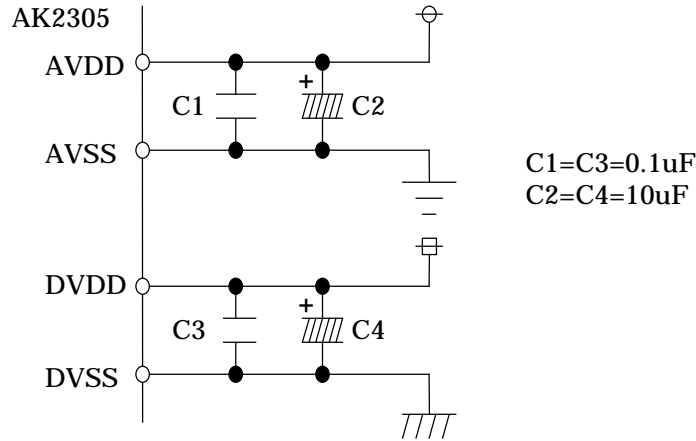

To use the same supply for both digital and analog power supply (DVDD and AVDD), insert 10Ω resistor between AVDD and DVDD. AVSS and DVSS must be separated on the board, and connected them at power supply unit.

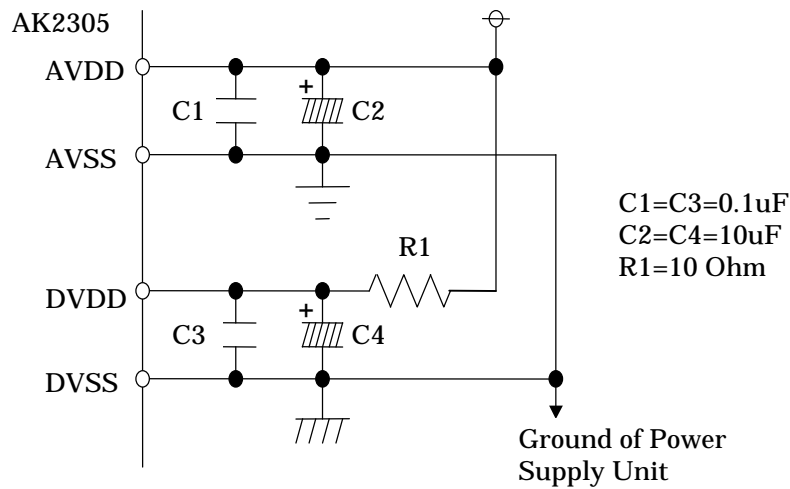

PACKAGING INFORMATION

- 48pin LQFP

Marking

- (1) Pin#1 indication
- (2) Date Code: 5 digit XXXXX
- (3) Marketing Code: AK2305
- (4) AKM Logo

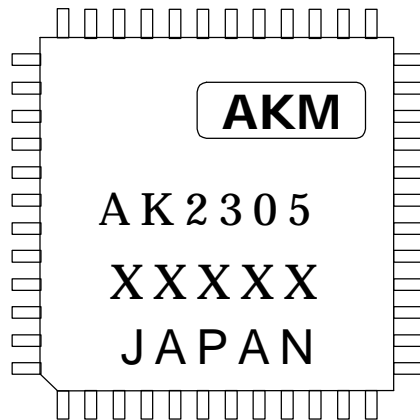

Outline Dimensions

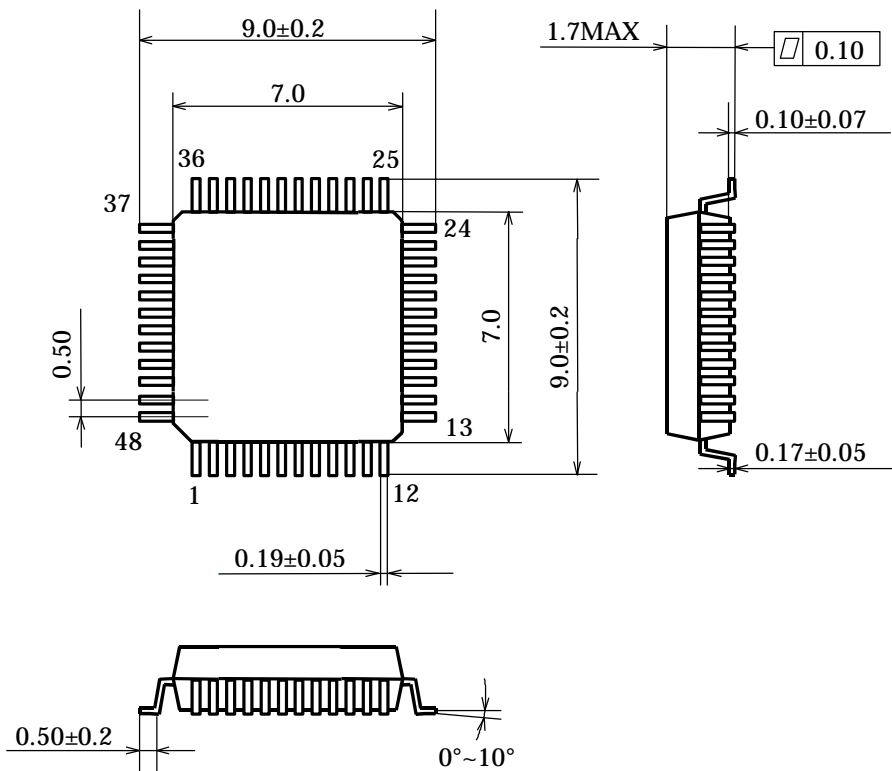

IMPORTANT NOTICE

AKM assumes no liability for infringement of any patent, intellectual property, or other right in the application or use of any information contained herein.

Any export of these products, or devices or systems containing them, may require an export license or other official approval under the law and regulations of the country of export pertaining to customs and tariffs, currency exchange, or strategic materials.

AKM products are neither intended nor authorized for use as critical components in any safety, life support, or other hazard related device or system, and AKM assumes no responsibility relating to any such use, except with the express written consent of the Representative Director of AKM. As used here:

- (a) A hazard related device or system is one designed or intended for life support or maintenance of safety or for applications in medicine, aerospace, nuclear energy, or other fields, in which its failure to function or perform may reasonably be expected to result in loss of life or in significant injury or damage to person or property.
- (b) A critical component is one whose failure to function or perform may reasonably be expected to result, whether directly or indirectly, in the loss of the safety or effectiveness of the device or system containing it, and which must therefore meet very high standards of performance and reliability.

It is the responsibility of the buyer or distributor of an AKM product who distributes, disposes of, or otherwise places the product with a third party to notify that party in advance of the above content and conditions, and the buyer or distributor agrees to assume any and all responsibility and liability for and hold AKM harmless from any and all claims arising from the use of said product in the absence of such notification.



LittleDiode supplies new, hard to find or obsolete electronic components and semiconductors all over the world.

With over two million different components listed you are sure to find the part you need.

Feel free to visit us today at our online store:

LittleDiode.com

Looking forward to providing you with the best possible service.