



# AK4541

## AC'97™ Rev 2.1 Multimedia Audio CODEC

**Features**

- **AC'97 Rev. 2.1 Compliant**
- **18bit Resolution A/D and D/A**
- **Exceeds a PC98/99 Performance Categories:**
  - A/D..... 87dBA SNR
  - D/A..... 87dBA SNR
  - D/A+Mixer..... 85dBA SNR
  - A-A..... 92dBA SNR
- **Analog Inputs:**
  - 4 Stereo Inputs: LINE, CD, VIDEO, AUX
  - Speakerphone and PC BEEP Inputs
  - 2 Independent MIC Inputs
- **Direct PC\_Beep Pass Through for lower system costs**
- **Analog Output:**
  - Stereo LINE Output with volume control
  - True Line Level with volume control
  - Mono Output with volume control
- **Multiple codec Capability**
  - The AK4541 can work as a Primary or Secondary.
- **EAPD(External Amplifier Powerdown) Support**
- **Power Supplies:**
  - Analog 3.3V, Digital 3.3V
- **Lower Power Consumption:**
  - 135mW at full operation
- **48 Pin LQFP Package**

**General Description**

The AK4541 is a 18bit high performance codec compliant with Audio Codec '97 Rev 2.1 requirements. The AC Link serial interface allows the AK4541 to be used with digital controllers as well as custom logic accelerators to meet PC98 and PC99 requirements for a PCI audio solution.

The AK4541 provides two pairs of stereo outputs with independent volume controls along with a mono output, multiple stereo and mono inputs, are combined to create flexible mixing, gain and mute functions to provide a complete integrated audio solution for PCs.

The AK4541 can function as a Primary AC'97 or Secondary codec depending on the codec ID configuration(Multiple codec extension), making the AK4541 suitable for the docking station application and multiple codec applications such as 4 speaker output or 6 speaker output.

Sampling at 48kHz, the AK4541 provides excellent audio performance. It offers extreme low power consumption, and flexible power-down modes for use in Sub-NoteBook, laptops, desktop PCs, and aftermarket add-in boards.

Like the earlier pin-compatible AK4540, AK4542 and AK4543, the AK4541 is available in a compact 48-lead LQFP package.

The AK4541 is a pin compatible upgrade for the AK4540, AK4542 and AK4543, some software changes will be required to experience the extra functions of the AK4541.

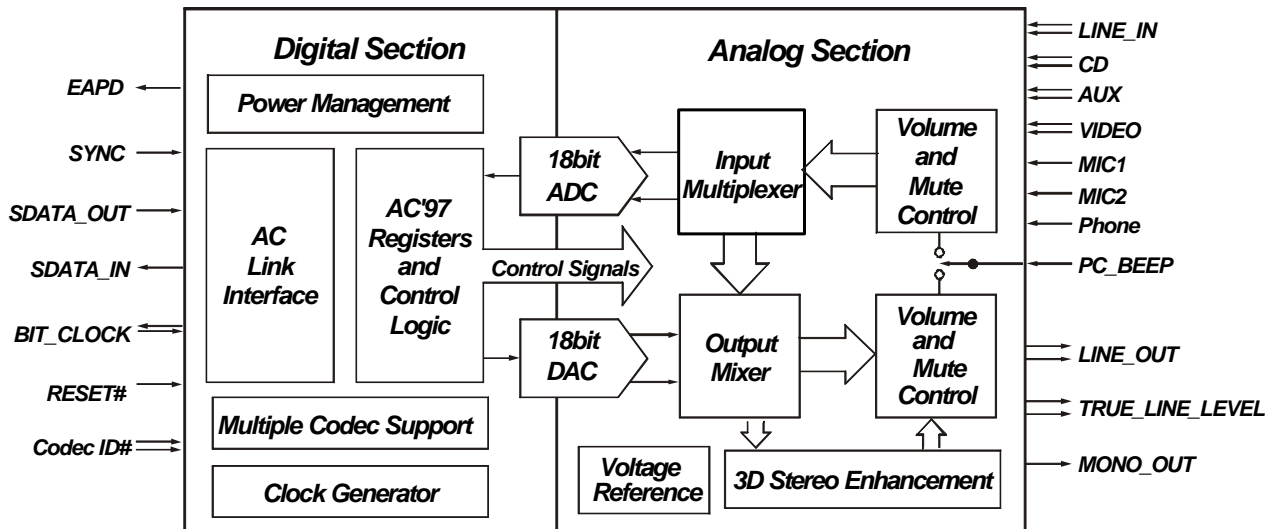

\* AKM assumes no responsibility for the usage beyond the conditions in this data sheet.

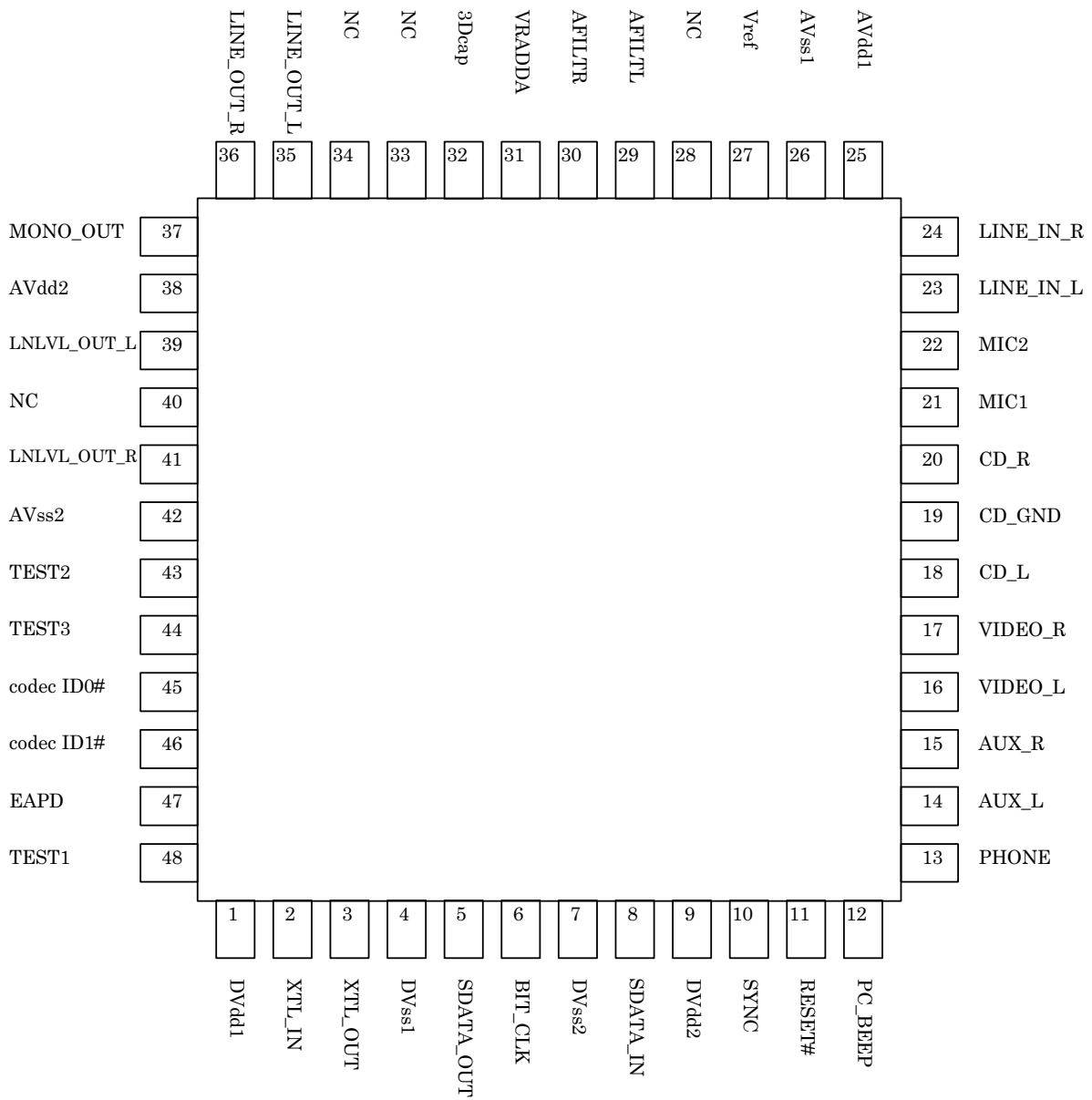

Pin/Function			
No.	Signal Name	I/O	Description
1	DVdd1	-	Digital power supply; 3.3V(DVdd1 = DVdd2) 0.1uF + 4.7uF capacitors should be connected to digital ground.
2	XTL_IN (MCLKI)	I	24.576MHz(512fs) crystal is normally connected. If a crystal is not connected, an external clock can be used.
3	XTL_OUT(open)	O	24.576MHz(512fs) crystal. If an external clock is used, this pin should be open.
4	DVss1	-	Digital Ground; 0V This pin should be directly connected to DVss2 on board.
5	SDATA_OUT	I	Serial 256-bit AC'97 data stream from digital controller
6	BIT_CLK	IO	12.288MHz(256fs) serial data clock Output when Primary codec(codec ID=00). Input when Secondary codec(codec ID=01, 10, 11).
7	DVss2	-	Digital Ground; 0V This pin should be directly connected to DVss1 on board.
8	SDATA_IN	O	Serial 256-bit AC'97 data stream to digital controller
9	DVdd2	-	Digital power supply; 3.3V(DVdd1 = DVdd2) 0.1uF + 4.7uF capacitors should be connected to digital ground.
10	SYNC	I	AC'97 Sync Clock, 48kHz(1fs) fixed rate sampling rate
11	RESET#	I	AC'97 Master Hardware Reset
12	PC_BEEP	I	PC Speaker beep pass through
13	PHONE	I	From telephony subsystem speakerphone
14	AUX_L	I	Aux Left Channel
15	AUX_R	I	Aux Right Channel
16	VIDEO_L	I	Video Audio Left Channel
17	VIDEO_R	I	Video Audio Right Channel
18	CD_L	I	CD Audio Left Channel
19	CD_GND	I	CD Audio analog ground; 0V CD_GND or analog ground should be connected.
20	CD_R	I	CD Audio Right Channel
21	MIC1	I	Desktop Microphone Input
22	MIC2	I	Second Microphone Input
23	LINE_IN_L	I	Line In Left Channel
24	LINE_IN_R	I	Line In Right Channel
25	AVdd1	-	Analog power supply; 3.3V(AVdd1=AVdd2) 0.1uF + 4.7uF capacitors should be connected to AVss1(analog ground).
26	AVss1	-	Analog Ground; 0V
27	Vref	O	Reference Voltage Output; 0.1uF + 4.7uF capacitors should be connected to Avss1(analog ground).
28	NC	-	No Connection
29	AFILTL	O	Anti-Aliasing Filter Cap; Connected to analog ground with 1nF capacitor.
30	AFILTR	O	Anti-Aliasing Filter Cap; Connected to analog ground with 1nF capacitor.
31	VRADDA	O	Vref for ADC and DAC; 0.1uF capacitor should be connected to analog ground.
32	3Dcap	O	3D Enhancement Cap; 27nF capacitor should be connected to analog ground.
33	NC	-	No Connection
34	NC	-	No Connection
35	LINE_OUT_L	O	Line Out Left Channel
36	LINE_OUT_R	O	Line Out Right Channel
37	MONO_OUT	O	To telephony subsystem speakerphone
38	AVdd2	-	Analog power supply; 3.3V(AVdd1=AVdd2) 0.1uF capacitor should be connected to AVss2(analog ground).
39	LNLVL_OUT_L	O	True Line Level Out Left Channel
40	NC	-	No Connection
41	LNLVL_OUT_R	O	True Line Level Out Right Channel
42	AVss2	-	Analog Ground; 0V
43	TEST2	I	Test pin (This pin should be open for normal operation)
44	TEST3	I	Test pin (This pin should be open for normal operation)
45	Codec ID0#	I	Codec ID configuration(ID select input for multiple codec extension) See Page20.
46	Codec ID1#	I	Codec ID configuration(ID select input for multiple codec extension) See Page20.
47	EAPD	O	External amplifier powerdown See Page 20.

48	TEST1	I	Test pin (This pin should be open for normal operation)
----	-------	---	---

Absolute Maximum Rating				
-------------------------	--	--	--	--

AVss1, AVss2, DVss1, DVss2 =0V (Note 1)

Parameter	Symbol	min	max	Units
Power Supplies				
Analog(AVdd1 & AVdd2)	VA	-0.3	6.0	V
Digital(DVdd1 & DVdd2)	VD	-0.3	6.0	V
Input Current (any pins except for supplies)	IIN	-	±10	mA
Analog Input Voltage	VINA	-0.3	VA+0.3	V
Digital Input Voltage	VIND	-0.3	VD+0.3	V
Ambient Temperature	Ta	-10	70	°C
Storage Temperature	Ta	-65	150	°C

Note 1: All voltages with respect to ground.

AGND(AVss1, AVss2) and DGND(DVss1, DVss2) must be the same voltage.

Warning: Operation at or beyond these limits may results in permanent damage to the device.

Normal operation is not guaranteed at these extremes.

Recommended Operating Condition						
---------------------------------	--	--	--	--	--	--

AGND, DGND=0V (Note 1)

Parameter	Symbol	min	typ	max	Units
Power Supplies					
AK4541					
Analog	VA	3.135	3.3	3.465	V
Digital	VD	3.135	3.3	3.465	V

Note 1 : All voltages with respect to ground.

## AK4541 Analog Characteristics

Ta=25°C, AVdd=DVdd=3.3V±5% or 5V±5%, fs=48KHz, Signal Frequency =1kHz

All volume setting for ADC/DAC performance measurement is 0dB.

Parameter	min	Typ	max	Units
<b>Audio-ADC</b>				
Resolution			18	Bits
S/N (A weighted)	82	87		dB
S/(N+D) (-1dB analog input)	70	76.5		dBFS
Inter Channel Isolation	68	75		dB
Inter Channel Gain Mismatch			0.5	dB
Full Scale Input Voltage	0.6	0.7	0.8	Vrms
Power Supply Rejection		50		dB
<b>Audio DAC: measured at AOUTL/AOUTR via MIXER path</b>				
Resolution			18	Bits
S/N (A weighted) : mixer+DAC measured at AOUT	80	85		dB
S/(N+D) (-1dB digital input)	70	80		dBFS
Inter Channel Isolation	70	80		dB
Inter Channel Gain Mismatch			1.0	dB
Full Scale Output Voltage	0.56	0.66	0.76	Vrms
Total Out-of-Band Noise (28.8kHz - 100kHz)		-70		dB
Power Supply Rejection		50		dB
<b>MIC Amplifier / MUX</b>				
Gain : 20dB is selected	18	20	22	dB
<b>Master volume (Mono, Stereo, True Line Level Out) : 1.5dB x 32 step</b>				
Step Size		-1.5		dB
Attenuation Control Range	-46.5		0	dB
Load Resistance	10			kΩ
<b>PC Beep : 3dB x 16 step</b>				
Step Size		-3.0		dB
Attenuation Control Range	-45		0	dB
<b>Analog Mixer : 1.5dB x 32 step</b>				
Step Size		-1.5		dB
Gain Control Range	-34.5		+12	dB
<b>Record Gain : 1.5dB x 16 step</b>				
Step Size		+1.5		dB
Gain Control Range	0		+22.5	dB
<b>Mixer</b>				
Input Voltage (except for MIC)		0.7		Vrms
Input Voltage MIC : Gain = 0dB		0.7		Vrms
MIC : Gain = 20dB		0.07		Vrms
S/N(A weighed) : 0dB setting, 1 path is selected at Mixer CD to AOUT: Other analog input to AOUT	83	92		dB
Input Impedance (Input gain=0dB, Rec_MUTE=off) PC_BEEP only	(10)	80		kΩ
Others(PHONE, LINE, CD, AUX, VIDEO)	(10)	40		kΩ
Input Impedance (MIC1 and MIC2)	(10)	22		kΩ
<b>Power Supplies</b>				
Analogue Power Supply Current (AVdd1 & AVdd2) All ON mode(all PR_bits are 0) Cold Reset status(Reset#=L, Vref is ON) All OFF mode(all PR_bits are 1)		34 2.2 0	51 5 0.2	mA mA mA
Digital Power Supply Current (DVdd1 & DVdd2) All ON mode(all PR_bits are 0) at DVDD=3.3V All OFF mode(all PR_bits are 1)		6.6 0	10 0.2	mA mA

## Filter Characteristics

Ta=25°C, AVdd=DVdd=3.3V±5% or 5V±5% , fs=48KHz(fixed)

Parameter	min	typ	Max	Units
ADC Digital Filter (Decimation LPF)				
Passband (±0.2dB)	0		19.2	kHz
Stopband	28.8			kHz
Stopband Attenuation	70			dB
Group Delay			0.5	ms
ADC Digital Filter (HPF)				
Frequency Response;	-3dB	7.5		Hz
	-0.5dB	21		
	-0.1dB	49		
DAC Digital Filter				
Passband (±0.2dB)	0		19.2	kHz
Stopband	28.8			kHz
Group Delay			0.5	ms
Stopband Rejection	70			dB
DAC Post filter				
Passband Frequency Response (0 - 19.2kHz)		±0.1		dB

## AK4541 DC Characteristics

Ta=-10~70°C, VD= VA=3.3V±5%, 50pF external load

Parameter	Symbol	min	typ	Max	Units
“H” level input voltage	VIH		-	-	V
XTAL_IN		0.7xVD			V
RESET#, SYNC, SDATA_OUT, BIT_CLK		0.7xVD			V
ID0#, ID1#, SEL_CMOS(Pull up)		0.8xVD			V
“L” level input voltage	VIL		-		V
XTAL_IN				0.3xVD	V
RESET#, SYNC, SDATA_OUT, BIT_CLK				0.3xVD	V
ID0#, ID1#, SEL_CMOS(Pull up)				0.2xVD	V
“H” level output voltage Iout= -1mA	VOH	VD-0.5	-	-	V
“L” level output voltage Iout= 1mA	VOL	-	-	0.5	V
Input leakage current(exclude pull up pins)	Iin	-	-	±10	μA
Pull up resistance	Rup	50	100	200	kΩ

## Switching Characteristics

Ta=25°C, AVdd=DVdd=3.3V±5%, 50pF external load

Parameter	Symbol	min	Typ	max	Units
Master Clock Frequency Note) If Crystal is not used.	Fmclk	- 45	24.576 50	- 55	MHz %
AC link Interface Timing					
BIT_CLK frequency	Fbclk		12.288		MHz
BIT_CLK clock Period(Tbclk=1/Fbclk)	Tbclk	-	81.38		ns
BIT_BLK low pulse width	Tclk_low	36.0	40.7	45	ns
BIT_BLK low pulse width	Tclk_high	36.0	40.7	45	ns
BIT_CLK rise time	Trise_clk	-	-	6	ns
BIT_CLK fall time	Tfall_clk	-	-	6	ns
SYNC frequency		-	48	-	kHz
SYNC low pulse width	Tsync_low	-	19.5 (240 cycle)	-	μs (Tbclk)
SYNC high pulse width	Tsync_high	-	1.3 (16 cycle)	-	μs (Tbclk)
SYNC rise time	Trise_sync	-	-	6	ns
SYNC fall time	Tfall_sync	-	-	6	ns
Setup time(SDATA_IN,SDATA_OUT)	Tsetup	10.0	-	-	ns
Hold time(SDATA_IN,SDATA_OUT)	Thold	25.0	-	-	ns
SDATA_IN delay time from BIT_CLK rising edge	Tdelay	-	-	15	ns
SDATA_IN rise time	Trise_din	-	-	6	ns
SDATA_IN fall time	Tfall_din	-	-	6	ns
SDATA_OUT rise time	Trise_dout	-	-	6	ns
SDATA_OUT fall time	Tfall_dout	-	-	6	ns
Cold Rest (SDATA_OUT=L, SYNC=L)					
RESET# active low pulse width	Trst_low	1.0	-	-	μs
RESET# inactive to BIT_CLK delay	Trst2clk	162.8 (2 cycle)			ns (Tbclk)
Warm Rest Timing					
SYNC active low pulse width	Tsync_high	1.0	1.3 (16 cycle)	-	μs (Tbclk)
SYNC inactive to BIT_CLK delay	Tsync2clk	162.8 (2 cycle)			ns (Tbclk)
AC-link Low Power Mode Timing					
End of Slot 2 to BIT_CLK, SDATA_IN Low	Ts2_pdwn	-	-	1.0	μs
Activate Test Mode Timing					
Setup to trailing edge of RESET#	Tsetup2rst	15.0	-	-	ns
Hold from RESET# rising edge	Thold2rst	100	-	-	ns
Rising edge of RESET# to Hi-Z	Toff	-	-	50	ns
Falling edge of RESET# to "L"	Tlow	-	-	50	ns

Note) The use of a crystal is recommended. If a master clock is supplied (or if an external oscillator is used), Master Clock should be supplied to XTAL\_IN and XTAL\_OUT should be left open.

■ Power On

Note that a AK4541 must be in cold reset at power on and RESET# must be low until master clock becomes stable, or a reset must be done once master clock is stable. AVdd or DVdd can be powered from independent supplies.

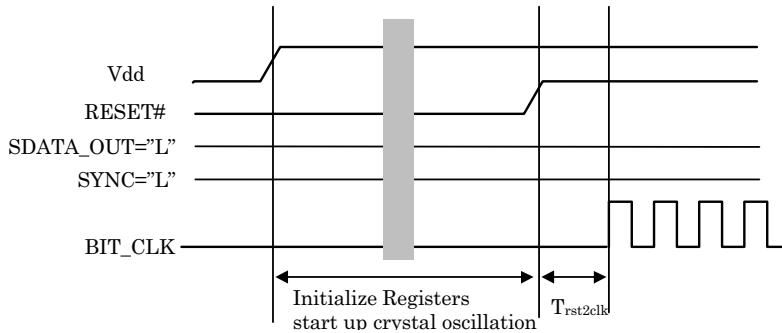

When using the AK4541 in the multiple codec mode, all codec's connected to the AC-link are waken up at the same time. A common reset line should be used to insure clock synchronization after power up.

■ Cold Reset Timing

Note that both SDATA\_OUT and SYNC must be low at the rising edge of RESET# for a cold reset to occur. The AK4541 initializes all registers including the Powerdown Control Registers, BIT-CLK is reactivated and each analog output is in Hi-Z state except for PC Beep while RESET# pin is low. The PC Beep is directly routed to L & R line outputs when AK4541 is in Cold Reset. This is done to allow system sounds to be passed to speaker removing for an internal redundant speaker.

At the rising edge of RESET#, the AK4541 initiates the initialization of analog circuit, which takes 516fs cycles. After that, the mixer of the AK4541 is ready for normal operation.

Status bit in the slot 0 is "0" (not ready) when the AK4541 is in RESET period ("L") or in initialization process. After initialization cycles, the status bit goes to "1" indicating a ready condition.

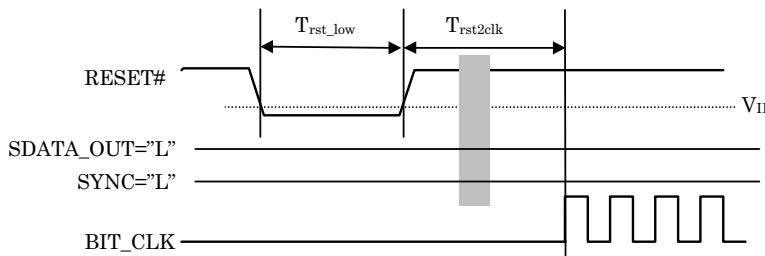

When the AK4541 is used under the multiple codec configuration and when cold reset is issued, all AK4541 connected to the AC-link will execute a cold reset concurrently.

■ Warm Reset

The AK4541 initiates a warm reset process by receiving a single pulse on the sync(Pin10). The AK4541 then clears PR4 bit and PR5 bit in the Powerdown Control Register. However, warm reset does not influence PR0~PR3 or PR6,7 bits in Powerdown Control Register(26h). Note that SYNC signal should synchronize with BIT\_CLK after AK4541 starts to output BIT\_CLK clock. And if an external clock is used, an external clock should be supplied before issuing a sync pulse for warm reset.

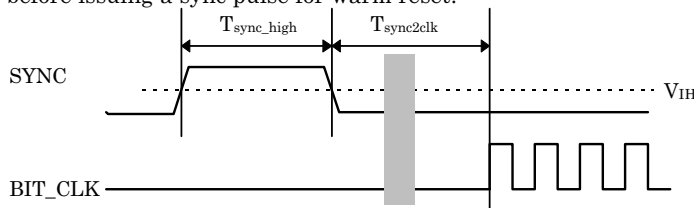

Please refer to Powerdown/Powerup sequence of multiple codec configuration on the warm reset when the AK4541 is used under the multiple codec configuration .(See page 24, 25)

■BIT\_CLK Timing

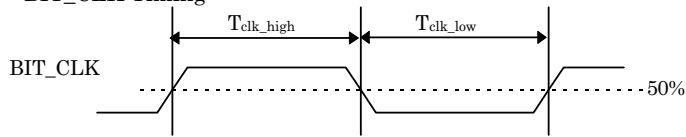

■SYNC Timing

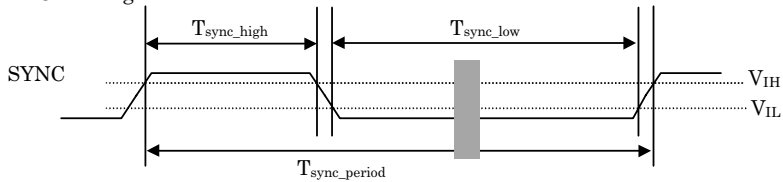

■Setup and Hold Timing

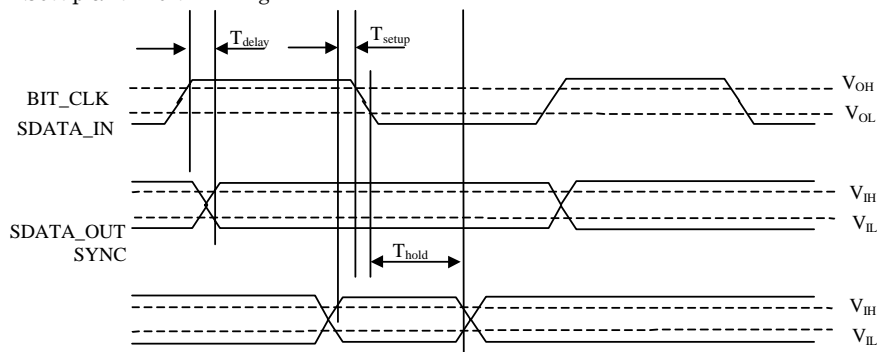

■Signal Rise and Fall Times

(50pF external load : from 10% 90% of DVdd)

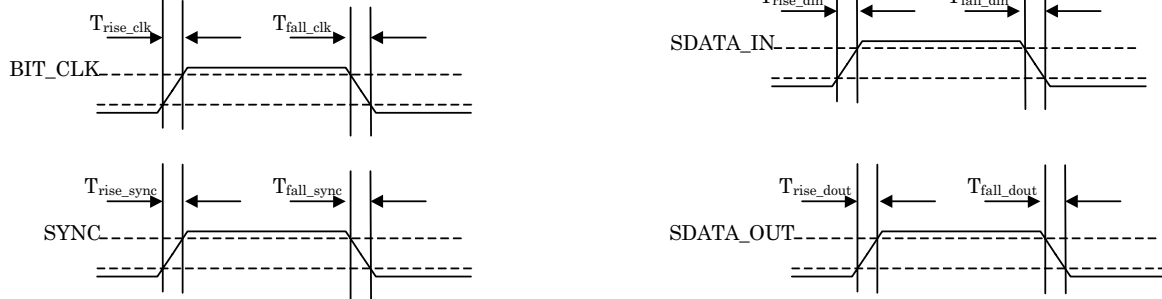

■AC-link Low Power Mode Timing

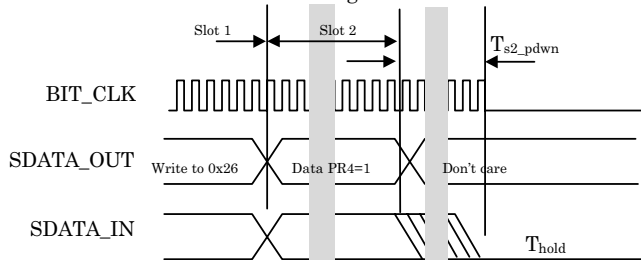

### ■ Activate Test Mode

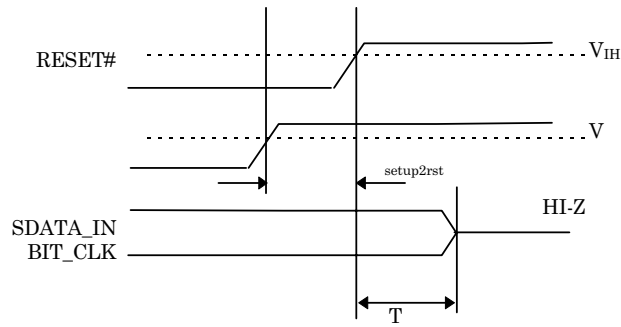

### ■ AKM Test Mode

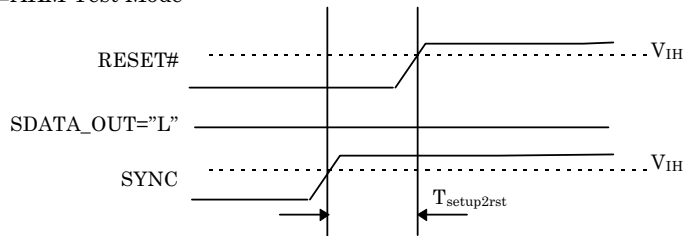

#### Notes:<sup>1</sup>

1. All AC-link signals are normally low through the trailing edge of RESET#. Bringing SDATA\_OUT high for the rising edge of RESET# causes the AK4541 AC-link outputs to go high impedance which is suitable for ATE in circuit testing. Note that the AK4541 enters in the ATE test mode regardless SYNC is high or low.
2. Bringing both SYNC high and SDATA\_OUT low for the rising edge of RESET# causes AKM test mode.
3. Once test modes have been entered, the only way to return to the normal operating state is to issue "cold reset" which issues RESET# with both SYNC and SDATA\_OUT low.

<sup>1</sup> All the following sentences written with small italic font in this document quote the AC'97 component specification.

General Description
---------------------

### ■ AC '97 Connection to the Digital AC '97 controller

<sup>2</sup>AC '97 communicates with its companion AC '97 controller via a digital serial link, "AC-link". All digital audio streams, and command/status information are communicated over this point to point serial interconnect. A breakout of the signals connecting the two is shown in the following figure.

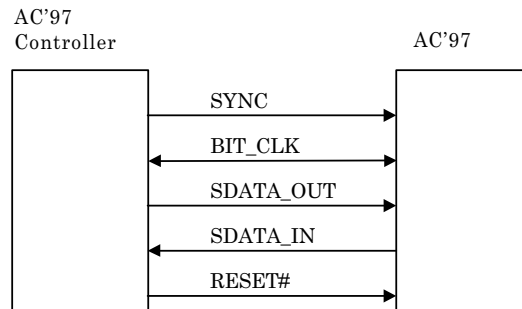

### ■ AC'97 Digital Interface

The AK4541 incorporates a 5 pin digital serial interface that links it to the AC '97 controller. AC-link is a bi-directional, fixed rate(48kHz), serial PCM digital stream. It handles multiple input, and output audio streams, as well as control register accesses employing a time division multiplexed (TDM) scheme. The AC-link architecture divides each audio frame into 12 outgoing and 12 incoming data streams, each with 20-bit sample resolution. DAC and ADC resolution of the AK4541 is 18 bit resolution. The data streams currently defined by the AC '97 specification include:

- |  |                       |
|--|-----------------------|
| <b>● PCM Playback</b>                        | <b>2 output slots</b> |
| <i>2 channel composite PCM output stream</i> |                       |
| <b>● PCM Record data</b>                     | <b>2 input slots</b>  |
| <i>2 channel composite PCM input stream</i>  |                       |
| <b>● Control</b>                             | <b>2 output slot</b>  |
| <i>Control register write port</i>           |                       |
| <b>● Status</b>                              | <b>2 input slots</b>  |
| <i>Control register read port</i>            |                       |

SYNC, fixed at 48 KHz, is derived by dividing down the serial bit clock (BIT\_CLK). BIT\_CLK, fixed at 12.288 MHz, provides the necessary clocking granularity to support 12, 20-bit outgoing and incoming time slots. AC-link serial data is transitioned on each rising edge of BIT\_CLK. The receiver of AC-link data, the AK4541 for outgoing data and AC '97 controller for incoming data, samples each serial bit on the falling edges of BIT\_CLK.

The AK4541 outputs BIT\_CLK when it is assigned as Primary codec by the codec ID configuration ID1# and ID0#. The other hand, the AK4541 receives BIT\_CLK when assigned as the Secondary codec from the Primary device.

The AC-link protocol provides for a special 16-bit slot (Slot 0) wherein each bit conveys a valid tag for its corresponding time slot within the current audio frame. A "1" in a given bit position of slot 0 indicates that the corresponding time slot within the current audio frame has been assigned to a data stream, and contains valid data. If a slot is "Tagged" invalid, it is the responsibility of the source of the data, (The AK4541 for the input stream, AC '97 controller for the output stream), to stuff all bit positions with 0's during that slot's active time.

SYNC remains high for a total duration of 16 BIT\_CLKs at the beginning of each audio frame. The portion of the audio frame where SYNC is high is defined as the "Tag Phase". The remainder of the audio frame where SYNC is low is defined as the "Data Phase".

Note that SDATA\_OUT and SDATA\_IN data is delayed one BIT\_CLK because AC'97 controller causes SYNC signal high at a rising edge of BIT\_CLK which initiates a frame.

"Output" stream means the direction from AC'97 controller to the AK4541, and "Input" stream means the direction from the AK4541 to AC'97 controller

<sup>2</sup>All the following sentences written with small italic font in this document quote the AC'97 component specification.

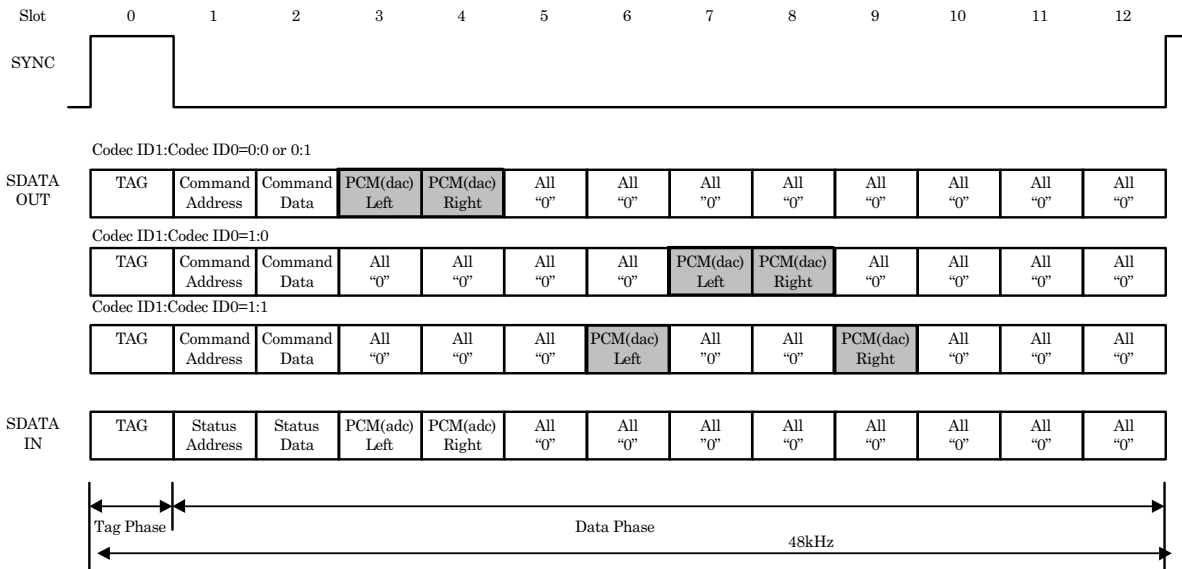

AC-link protocol identifies 13slots of data per frame. The frequency of sync is fixed to 48kHz. Only Slot 0, which is the Tag phase, is 16bits, all other slots are 20bits in length. These slots are explained in later sections.

AC-link Audio Output Frame (SDATA\_OUT)

a)Slot 0

Primary codec (Codec ID1 : Codec ID0 = 0 : 0)

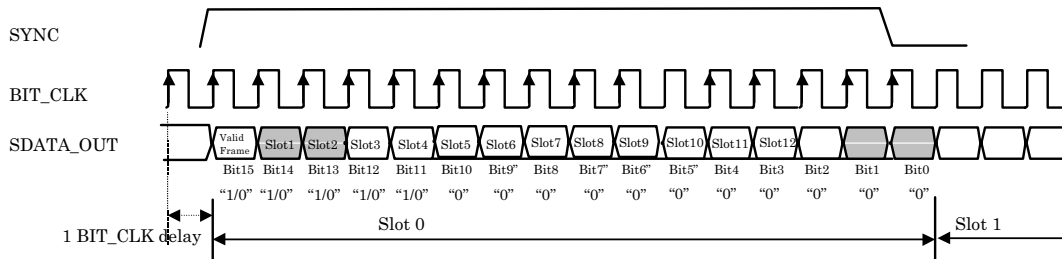

Secondary codec (Codec ID1 : Codec ID0 ≠ 0 : 0)

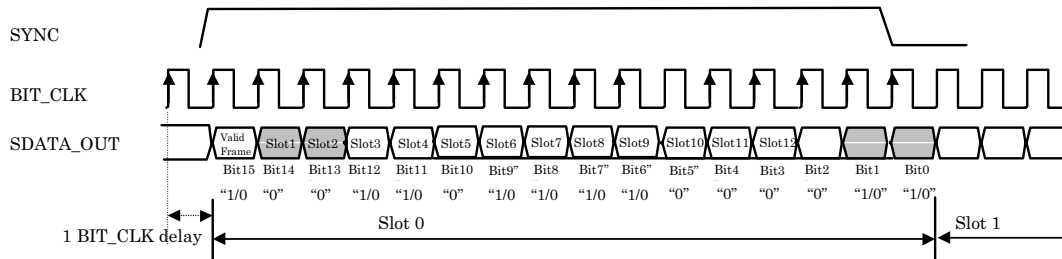

The AK4541 checks bit15 (valid frame bit). Note that when the valid frame bit is "1", at least one bit14-6 (slot 1-9) or bit1-0 must be valid, bit5-2 will be "0"and should be ignored.

If bit15 is "0", the AK4541 ignores all following information in the frame.

The AK4541 then checks the validity of each bit in the TAG phase (slot 0).

If each bit is "0", the AK4541 ignores the slot indicated by "0". On the other hand, if each bit is "1", the slot is valid. All bits in slot10-12(bit5-3) are "0" and bit2 is also "0".

The AK4541 monitors bit1 and 0, which are codec ID configuration bits used in multiple codec implementations.

These bits are used to identify which codec the frame data is issued to.

When codec ID configuration bits1 and 0 which are set by the codec ID configuration 45/46 strapping pins(codec ID0# and ID1#) are set to zero(00), the frame is aimed for the Primary codec. And when codec ID configuration bit1 and 0 are set to non-zero values(01, 10, or 11), the frame is meant for Secondary codec.

A new audio output frame begins with a low to high transition of SYNC. SYNC is synchronous to the rising edge of BIT\_CLK. On the immediately following falling edge of BIT\_CLK, the AK4541 samples the assertion of SYNC. This falling edge marks the time when both sides of AC-link are aware of the start of a new audio frame. On the next rising of BIT\_CLK, the AC '97 controller transitions SDATA\_OUT into the first bit position of slot 0 (Valid Frame bit). Each new bit position is presented to AC-link on a rising edge of BIT\_CLK, and subsequently sampled by the AK4541 on the following falling edge of BIT\_CLK. This sequence ensures that data transitions, and subsequent sample points for both incoming and outgoing data streams are time aligned.

Data should be sent to the AC'97 codec with MSB first through the Pin labeled SDATA\_OUT.

The following table shows the relationship of bits14&13 and the Read/Write operations depending on codec ID configuration.

Bit 15 Valid Frame	Bit 14: Slot1 Valid Bit (Command Address)	Bit 13: Slot 2 Valid Bit (Command Data)	Read/Write Operation of Primary AK4541	Read/Wrire Operation of Secondary AK4541
1	1	1	Read/Write(Normal Operation)	Ignore
1	0	1	Ignore	Ignore
1	1	0	Read: Normal Operation Write: Ignore	Ignore
1	0	0	Ignore	Read/Write(Normal Operation)

AK4541 Addressing: Slot0 Tag Bits

b)Slot1:Command Address Port

Slot1 gives the address of the command data, which is given in the slot 2. The AK4541 has 20 valid registers of 16bit data. See Page17(See AC'97 register map).

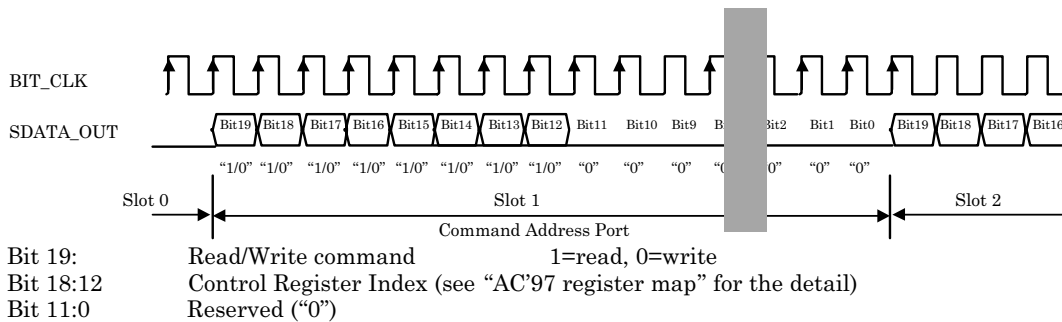

Bit18 is equivalent to the most significant bit of the index register address. The AK4541 ignores from bit11 to bit0. These bits will be reserved for future enhancement and must be stuffed with 0's by the AC'97 controller.

c)Slot2:Command Data Port

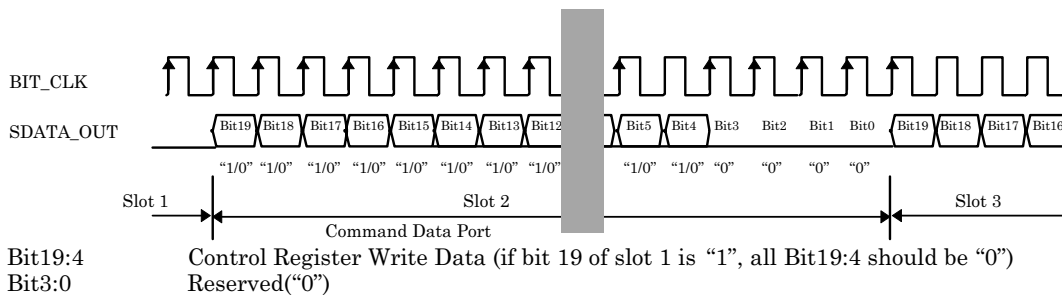

If bit19 in slot1 is "0", a write command, the AC'97 controller must output Command Data Port data in slot 2 of the same frame. If the bit19 in slot1 is "1", a read, the AK4541 will ignore any Command Data Port data in slot2.

Bit19 is equivalent to D15 bit of mixer register value.

## d)Slot3 PCM Playback Left Channel (18bits)

In the case of codec ID1:codec ID0=0:0 or 0:1, the AK4541 uses the playback(DAC) data format in slot3 for left channel.

Playback data format is 18bits MSB first 2's complement. The AC'97 controller should stuff bits1-0 with "0". If valid bit (slot3) in the slot 0 is invalid ("0"), the AK4541 interprets the data as all "0".

Bit19:2 Playback data  
Bit 1:0 "0"

## e)Slot4 PCM Playback Right Channel (18bits)

In the case of codec ID1:codec ID0=0:0 or 0:1, the AK4541 uses the playback(DAC) data format in the slot4 for right channel. Playback data format is MSB first. Data format is 18bits 2's complement. The AC'97 controller should stuff bits1-0 with "0". If valid bit (slot 4) in the slot 0 is invalid ("0"), the AK4541 interprets the data as all "0".

Bit19:2 Playback data  
Bit 1:0 "0"

## f)Slot5 is Not used in the AK4541

The AK4541 will ignore stuffed in this slot.

## g)Slot6 PCM Playback Left Channel (18bits)

In case of codec ID1:codec ID0=1:1, the AK4541 uses the playback(DAC) data in slot 6 for left channel.

Playback data format is 18bits MSB first 2's complement. The AC'97 controller should stuff bit1-0 with "0". If valid bit (slot6) in the slot 0 is invalid ("0"), the AK4541 interprets the data as all "0".

Bit19:2 Playback data  
Bit 1:0 "0"

## h)Slot7 PCM Playback Left Channel (18bits)

In case of codec ID1:codec ID0=1:0, the AK4541 uses the playback(DAC) data in slot7 for left channel.

Playback data format is 18bits MSB first 2's complement. The AC'97 controller should stuff bit1-0 with "0". If valid bit (slot7) in the slot 0 is invalid ("0"), the AK4541 interprets the data as all "0".

Bit19:2 Playback data  
Bit 1:0 "0"

## i)Slot8 PCM Playback Right Channel (18bits)

In case of codec ID1:codec ID0=1:0, the AK4541 uses the playback(DAC) data in slot8 for right channel.

Playback data format is 18bits MSB first 2's complement. The AC'97 controller should stuff bit1-0 with "0". If valid bit (slot8) in the slot 0 is invalid ("0"), the AK4541 interprets the data as all "0".

Bit19:2 Playback data  
Bit 1:0 "0"

## j)Slot9 PCM Playback Right Channel (18bits)

In case of codec ID1:codec ID0=1:1, the AK4541 uses the playback(DAC) data in slot 9 for right channel.

Playback data format is 18bits MSB first 2's complement. The AC'97 controller should stuff bit1-0 with "0". If valid bit (slot9) in the slot 0 is invalid ("0"), the AK4541 interprets the data as all "0".

Bit19:2 Playback data  
Bit 1:0 "0"

## k)Slot10-12 is Not used in the AK4541

The AK4541 will ignore stuffed in these data slots.

■AC-link Input Frame(SDATA\_IN)

Each AC-link frame consists of one 16bit tag phase and twelve 20bit slots used for data and control.

a)Slot0

Slot0 is a special frame, and consists of 16bits. Slot0 is also called the “Tag phase”. The AK4541 supports bits 15-11 and bits1-0. Each bit indicates “1”=valid(normal operation) or ready, “0”=invalid(abnormal operation) or not ready.

If the first bit in the slot 0 is valid, the AK4541 is ready for normal operation. <sup>3</sup>If the “Codec Ready” bit is invalid, the following bits and remaining slots are all “0”. The AC’97 controller should ignore the following bits in the slot 0 and all other slots.

Bit 14 means that Slot 1(Status Address) output is valid or invalid. And Bit 13 means that Slot 2(Status Data ) is valid or invalid.

The following table shows the relationship between Bit 14,13 and each Status of the AK4541.

Bit 15 (Codec Ready)	Bit 14 (Status Address)	Bit 13 (Status Data)	Status
1	1	1	There is a Read Command in the previous frame. Then both Slot 1 and Slot 2 output normal data. If the access to non-implemented register or odd register is requested, the AK4541 returns “valid 7-bit register address in slot 1 and returns “valid”0000h data in slot 2 on the next AC-link frame.
1	1	0	Prohibited or non-existing
1	0	0	There is no Read Command in the previous frame. Both Slot 1 and Slot 2 output All’0’.
1	0	1	Prohibited or non-existing

Note 1). The above Read sequence is done as response for previous frames read command. That is, if the previous frame is a Write Command, AK4541 outputs bit14 =”0”, bit13 =”0” and slot 1&2 = All’0’.

Bit12 means the output of Slot 3(PCM(ADC) Left) is valid or invalid. And Bit 11 means the output of Slot 4(PCM(ADC)Left) is valid or invalid. Bits10-0 are filled with “0”.

A new audio input frame begins with a low to high transition of SYNC. SYNC is synchronous to the rising edge of BIT\_CLK. On the immediately following falling edge of BIT\_CLK, the AK4541 samples the assertion of SYNC. This falling edge marks the time when both sides of AC-link are aware of the start of a new audio frame. On the next rising of BIT\_CLK, the AK4541 transitions SDATA\_IN into the first bit position of slot 0 (“Codec Ready” bit). Each new bit position is presented to AC-link on a rising edge of BIT\_CLK, and subsequently sampled by the AC ’97 controller on the following falling edge of BIT\_CLK. This sequence ensures that data transitions, and subsequent sample points for both incoming and outgoing data streams are time aligned.

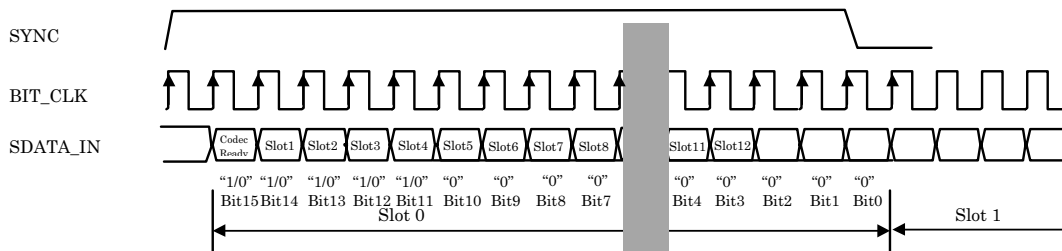

b)Slot1 Status Address Port

Audio input frame slot1’s stream echoes the control register index, for historical reference, for the data to be returned in slot2. (Assuming that slot1 valid bit and slot2 valid bit in the slot0 had been tagged “valid” by the AK4541)

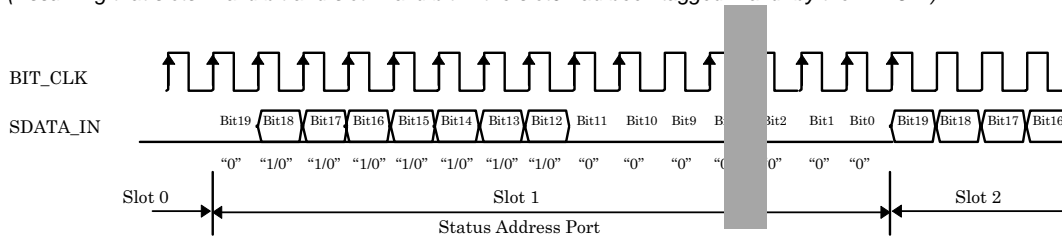

<sup>3</sup> When the AC’97 is not ready for normal operation, output bits are not specified in this documents and should be considered as invalid.

---

This address shows the register index for which data is being returned in the slot2.

This address port is a copy of slot1 of the output frame, and index address input to SDATA\_OUT is loop ed back to the AC'97 controller through SDATA\_IN. This allows the controller to insure the AK4541 receives the correct data.

c)Slot2: Status Data Port

Status data addressed by the command address port of Output Stream is output through SDATA\_IN pin.

Bit19:4 Control Register Read Data (the contents of indexed address in the slot 1)

Bit3:0 "0"

Note that the address of Status Data Port data is consistent with Status Address Port data of slot 1 *in the same frame*. If the read operation is issued in the frame N by the AC'97 controller, Status Data Port data is output through SDATA\_IN in the frame N+1. Note that data is only available in this frame, only one time and that the following frames are invalid if another read operation is not issued.

d)Slot3: PCM Record Left Channel

Record(ADC) data format is 18bits MSB first 2's complement. Lower 2bits of the frame are ignored. If ADC block is powered down, slot-3 valid bit in the slot 0 is invalid ("0"), and data is as all "0".

Bit19:2 Audio ADC left channel output

Bit1:0 "0"

e)Slot4: PCM Record Right Channel

Record(ADC) data format is 18bits MSB first 2's complement. Lower 2bits of the frame are ignored. If ADC block is powered down, slot-4 valid bit in the slot 0 is invalid ("0"), and data is as all "0".

Bit19:2 Audio ADC right channel output

Bit1:0 "0"

f)Slot5: Modem Line Codec

The AK4541 does not incorporate the modem codec, all bits are stuffed with "0" in this slot.

Bit19:0 "0"

g)Slot6: Microphone Record Data

The AK4541 does not incorporate the 3<sup>rd</sup> ADC for microphone, all bits are stuffed with "0" in this slot.

Bit19:0 "0"

h)Slots7-12 Reserved for future enhancement

Bits19:0 "0"

### ■AC'97 Register Map

Each Register is a 16bit word.

Note: The AK4541 outputs "valid" 0000h if the controller reads an unused or invalid register address.

Reg Num	Name	D15	D14	D13	D12	D11	D10	D9	D8	D7	D6	D5	D4	D3	D2	D1	D0	Default
00h	Reset	0	"0"	"1"	"0"	"1"	"1"	"0"	"1"	"0"	"1"	"0"	"1"	"0"	"0"	"0"	"0"	2D50h
02h	Master Volume	Mute	X	ML5	ML4	ML3	ML2	ML1	ML0	X	X	MR5	MR4	MR3	MR2	MR1	MR0	8000h
04	LINVL Volume	Mute	X	ML5	ML4	ML3	ML2	ML1	ML0	X	X	MR5	MR4	MR3	MR2	MR1	MR0	8000h
06h	Master Volume Mono	Mute	X	X	X	X	X	X	X	X	X	MR5	MR4	MR3	MR2	MR1	MR0	8000h
0Ah	PC_BEEP Volume	Mute	X	X	X	X	X	X	X	X	X	PV3	PV2	PV1	PV0	X	X	0000h
0Ch	Phone Volume	Mute	X	X	X	X	X	X	X	X	X	GN4	GN3	GN2	GN1	GN0	GN0	8008h
0Eh	Mic Volume	Mute	X	X	X	X	X	X	X	X	20dB	X	GN4	GN3	GN2	GN1	GN0	8008h
10h	Line In Volume	Mute	X	X	GL4	GL3	GL2	GL1	GL0	X	X	X	GR4	GR3	GR2	GR1	GR0	8808h
12h	CD Volume	Mute	X	X	GL4	GL3	GL2	GL1	GL0	X	X	X	GR4	GR3	GR2	GR1	GR0	8808h
14h	Video Volume	Mute	X	X	GL4	GL3	GL2	GL1	GL0	X	X	X	GR4	GR3	GR2	GR1	GR0	8808h
16h	Aux Volume	Mute	X	X	GL4	GL3	GL2	GL1	GL0	X	X	X	GR4	GR3	GR2	GR1	GR0	8808h
18h	PCM Out Volume	Mute	X	X	GL4	GL3	GL2	GL1	GL0	X	X	X	GR4	GR3	GR2	GR1	GR0	8808h
1Ah	Record Select	X	X	X	X	X	SL2	SL1	SL0	X	X	X	X	X	SR2	SR1	SR0	0000h
1Ch	Record Gain	Mute	X	X	X	GL3	GL2	GL1	GL0	X	X	X	GR3	GR2	GR1	GR0	GR0	8000h
20h	General Purpose	POP	X	3D	X	X	X	MIX	MS	LPBK	X	X	X	X	X	X	X	0000h
22h	3D Control	X	X	X	X	X	X	X	X	X	X	X	X	X	X	DP1	DP0	0000h
26h	Powerdown Ctrl/Stat	PR7	PR6	PR5	PR4	PR3	PR2	PR1	PR0	X	X	X	X	REF	ANL	DAC	ADC	na
28h	Extended Audio ID	ID1	ID0	X	X	X	AMAP	X	X	X	X	X	X	X	X	X	X	x200h
7Ch	Vendor ID1	"0"	"1"	"0"	"0"	"0"	"0"	"0"	"1"	"0"	"1"	"0"	"0"	"1"	"0"	"1"	"1"	414Bh
7Eh	Vendor ID2	"0"	"1"	"0"	"0"	"1"	"1"	"0"	"1"	"0"	"0"	"0"	"0"	"0"	"0"	"1"	"0"	4D02h

\*) Vender ID of AKM is "AKM": This ID has been approved by Intel.

\*) The AK4541 outputs "X" bits as "0".

\*) A write on "Invalid" registers will not affect the operation of the AK4541.

\*) ANL, DAC, ADC Bit in register 26h are all "0" following cold reset. When each section is ready for normal operation, the corresponding bit becomes "1". The Powerdown register(26h) is not affected by a write to Reset register(0h). See "Mixer Registers" in AC'97 specification for details. Vref is controlled only by PR3.

### ■Reset Register (Index 00h)

<Write>

When any value is written to this register, all registers in the AK4541 except for register "26h" Powerdown Ctrl/Stat Register are reset to the default values. The value of this register is not altered.

<Read>

Reading this register returns "2D50h" composed of the ID code of the part, a code for the type of 3D enhancement, 18

bit ADC/DAC resolution, and a code for True Line Level Out.

\*Setting D14 – D10 "01011" means AKM 3D enhancement which is registered in Audio Codec '97 Component Specification Rev 1.03 and 2.1.

\*Setting D8 "1" indicates 18bit ADC resolution and D6"1" does DAC resolution.

\*Setting D4 "1" means True Line Level Out is supported with Volume Control(Index 04h).

### ■ Play Master Volume Registers (Index 02h,06h) and LINVL(True Line Level Out) Volume Register(Index 04h)

The following table shows the relationship between bits and the attenuation value with step size of 1.5dB. The AK4541 has a range of 0dB to -46.5dB. The AK4541 does not support the optional MX5 bit.

The AK4541 detects when MX5 is set and set all 5 LSBs to 1s. Example: When the driver writes a "01xxxx" the AK4541 interpret that as "0011111". When this register is read, the returned value is "0011111".

Mute	MX5	MX4	MX3	MX2	MX1	MX0	Att.
0	0	0	0	0	0	0	0dB
0	0	0	0	0	0	1	-1.5dB
0	0	0	0	0	1	0	-3.0dB
0	0	0	0	0	1	1	-4.5dB
-----							
0	0	1	1	1	1	0	-45.0dB
0	0	1	1	1	1	1	-46.5dB
-----							
0	1	X	X	X	X	X	-46.5dB
-----							
1	X	X	X	X	X	X	Mute

### ■ PC BEEP Register (Index 0Ah)

The following table shows the relationship between bits and the attenuation value. The attenuation step is -3dB with a range of 0 to -45dB. PC\_BEEP of the AK4541 is mute off at default state.

*The PC BEEP is routed to L & R Line outputs directly when AK4541 is in a RESET State(Reset# is "L"). This is so that Power on Self Test(POST) codes can be heard by the user in case of a hardware problem with the PC. After Reset# goes "H", direct PC beep pass thru becomes OFF.*

Mute	PV3	PV2	PV1	PV0	Att.
0	0	0	0	0	0dB
0	0	0	0	1	-3.0dB
0	0	0	1	0	-6.0dB
-----					
0	1	1	1	1	-45.0dB
1	X	X	X	X	Mute

### ■ Analog Mixer Input Gain Registers (Index 0Ch-18h)

The following table shows the relationship between bits and the gain/attenuation value. Attenuation step is 1.5dB with a range of +12dB to -34.5dB.

Mute	Gx4	Gx3	Gx2	Gx1	Gx0	Att.
0	0	0	0	0	0	+12dB
0	0	0	0	0	1	+10.5dB
-----						
0	0	1	0	0	0	0dB
0	0	1	0	0	1	-1.5dB
-----						
0	1	1	1	1	0	-33.0dB
0	1	1	1	1	1	-34.5dB
1	X	X	X	X	X	Mute

### ■ Record Select Control Register (Index 1Ah)

SR2	SR1	SR0	Att.
0	0	0	Mic
0	0	1	CD In (R)
0	1	0	Video In (R)
0	1	1	Aux In (R)
1	0	0	Line In (R)
1	0	1	Stereo Mix (R)
1	1	0	Mono Mix
1	1	1	Phone

SR2	SL1	SL0	Att.
0	0	0	Mic
0	0	1	CD In (L)
0	1	0	Video In (L)
0	1	1	Aux In (L)
1	0	0	Line In (L)
1	0	1	Stereo Mix (L)
1	1	0	Mono Mix
1	1	1	Phone

### ■ Record Gain Register (Index 1Ch)

Mute	Gx3	Gx2	Gx1	Gx0	Gain
0	0	0	0	0	0dB
0	0	0	0	1	1.5dB
0	0	0	1	0	3.0dB
-----					
0	1	1	1	1	22.5dB
1	X	X	X	X	Mute

### ■ General Purpose Register (Index 20h)

The following table indicates how to control several miscellaneous functions of the AK4541.

	Bit	Function
POP	D15	PCM(DAC) Bypass 3D 0= Via 3D Path, 1= 3D Bypass
3D	D13	3D Stereo Enhancement 0=Off, 1=On
MIX	D9	3D Stereo Enhancement 0=Off, 1=On
MS	D8	Mic Select 0=Mic1, 1 =Mic2
LPBK	D7	ADC/DAC Loopback Mode 1= Loopback

An active bit("1") in D15(POP) will pass DAC output to Line\_OUT or LNLVL\_OUT directly, while a "0" in D15 will put DAC output into Input Mixers or AKM's 3D enhancement circuit.

D13(3D) will activate the AKM's 3D enhancement.

LPBK(ADC/DAC Loopback Mode) bit enables loopback of the ADC output to slot3 &4 of DAC input for both the Primary codec and Secondary codec on the same AC-Link Generally done for system testing.

### ■ 3D Control Register (Index 22h)

The following table shows the relationship between the bit and depth of 3D enhancement.

DP1	DP0	Depth	Recommended Application
0	0	0%	Off
0	1	50%	Audio
1	0	70%	Audio
1	1	100%	Game

### ■ Powerdown Control/Status Register (Index 26h)

BitsD0 to D3 are read only status bits. Any write to these bits will not affect the operation of the AK4541. These bits are used as status bits to subsections of the AC'97 codec. A "1" indicates the subsection of the AK4541 is "ready" or that is capable of performing in normal operation.

Bit	Function
REF D3	Vref up to nominal state 0=NOT ready, 1=ready,
ANL D2	Analog mixers, etc ready 0=NOT ready, 1=ready
DAC D1	DAC section ready to accept data 0=NOT ready, 1=ready
ADC D0	ADC section ready to transmit data 0=NOT ready, 1=ready

The power down modes are as follows.

Bit	Function
PR0 D8	PCM in ADC's & Input Mux Powerdown
PR1 D9	PCM out DACs Powerdown
PR2 D10	Analog Mixer Powerdown (Vref still on)
PR3 D11	Analog Mixer Powerdown (Vref off)
PR4 D12	Digital Interface (AC-link) Powerdown
PR5 D13	Internal Clk disable
PR6 D14	True Line Level Out Powerdown
PR7 D15	EAPD(External Amplifier Powerdown)

When PR3 is set to "1", the ADC, DAC, Mixer, True Line Level Out, and VREF are powered down even if any PRx bit are "0". When PR3 bit is reset to "0", the AK4541 resumes the previous state by referencing previous PRx bit. In this case, the AK4541 outputs corresponding slot-x valid bits in the slot 0 as "0" until the AK4541 results in normal operation(Codec Ready).

EAPD(External Amplifier Power Down) bit controls an external audio amplifier. EAPD="0" places a "0"(L) on the output pin, enabling an external audio amplifier, EAPD="1"(H) shuts it down. Powered up default is EAPD="0"(external audio amplifier enabled).

### ■ Extended Audio ID(Index 28h)

The Extended Audio ID(28h) is a read only register. 2bits D15&D14 can be read for codec identification. D15 ,14 are automatically set with the codec ID1#(46pin) and ID0#(45pin). ID1# and ID0# can be strapped and adopt inverted polarity and default to 00=Primary(via internal pull up) when left floating. Depended on codec ID configuration, the AK4541 is assigned to Primary codec or Secondary codec. Note that codec ID configuration has to be fixed before Powering up of the device.

ID1#(pin 46)		ID0#(pin45)		Configuration (Codec ID)
Physical Connection	Logic Value	Physical Connection	Logic Value	
NC	0	NC	0	Primary ID00
NC	0	GND	1	Secondary ID01
GND	1	NC	0	Secondary ID10
GND	1	GND	1	Secondary ID11

The AMAP (bit D9 of this read only register) will always be set to "1" indicating that DAC input slot will follow to AC'97 recommendation as shown in next table.(CODEC ID is configured via ID1#m ID0# pins)  
The audio DAC mapping can be changed based on the codec ID configuration.

Codec ID	AC-link Frame Data used for DACs		Comments
	PCM Left DAC uses data from Slot#	PCM Right DAC uses data from Slot#	
00	3	4	Original Definition(Master)
01	3	4	Original Definition(Docking)
10	7	8	Left/Right surround channels
11	6	9	Center/LFE channels

**■ Vendor ID Registers (Index 7Ch, 7Eh)**

*This register is a read only register that is used to determine the specific vendor identification. The ID method is Microsoft Plug and Play Vendor ID code with upper byte of 7Ch register, the first character of that id, lower byte of 7Ch register, the second character and upper byte of 7Eh register the third character. These three characters are ASCII encoded. Lower byte of 7E register is for the Vendor Revision number.*

AKM's vendor ID is "AKM", and revision number is 02. As ASCII code "A" is 41h, "K" is 4Bh, and "M" is 4Dh, Vendor ID registers are 414Bh and 4D02h respectively.

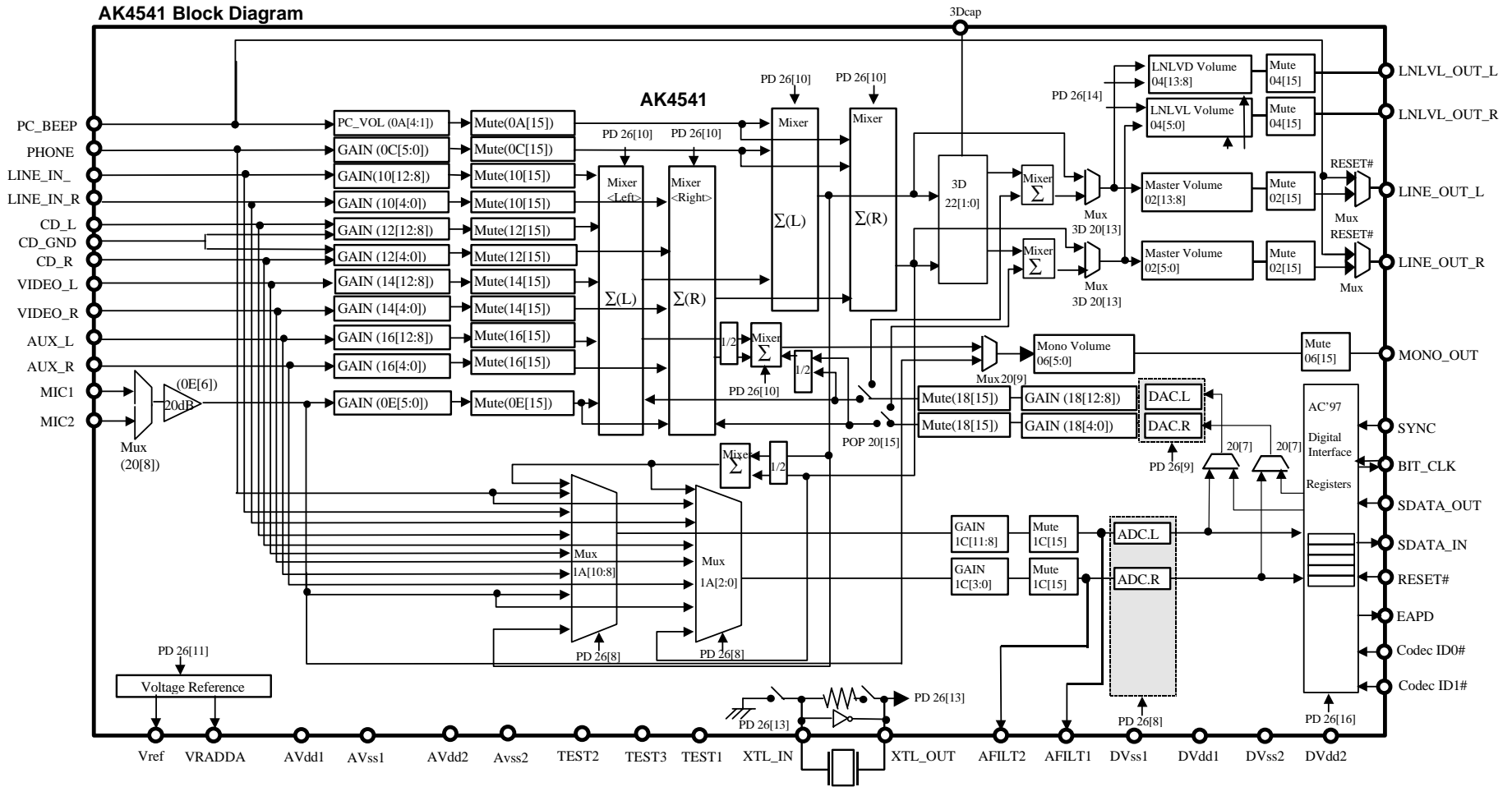

■Power Management/Low Power Modes

The AK4541 is capable of operating at multiple reduced power modes for when no activity is required. The state of power down is controlled by the Powerdown Register (26h). There are 8 separate commands for power down. See the table below for the different modes. As the AK4541 operates at static mode, the registers will not lose their values even if the master clock is stopped only upon power.

Powerdown Mode Truth Table

	ADC	DAC	Mixer	VREF	ACLINK	Internal CLK	LNLVL_OUT	EAPD
PR0="1"	PD	don't care	don't care	don't care	Don't care	don't care	don't care	don't care
PR1="1"	don't care	PD	don't care	don't care	Don't care	don't care	don't care	don't care
PR2="1"	don't care	don't care (No DAC out)	PD	don't care	Don't care	don't care	PD	don't care
PR3="1"	PD	PD	PD	PD	Don't care	don't care	PD	don't care
PR4="1"	PD	PD	don't care	don't care	PD	don't care	don't care	don't care
PR5="1"	PD	PD	don't care	don't care	PD	PD	don't care	don't care
PR6="1"	don't care	don't care	don't care	don't care	Don't care	don't care	PD	don't care
PR7="1"	don't care	don't care	don't care	don't care	Don't care	don't care	don't care	PD

\*: PD means Powerdown .

\*: No DAC out means that there is no PCM out because mixer is disabled.

From normal operation sequential writes to the Powerdown Register are performed to power down subsections of the AK4541 one at a time. After everything has been shut off, a final write (of PR4) can be executed to shut down the AC '97 digital interface (AC-link). The part will remain in sleep mode with all its registers holding their static values. To wake up, the AC '97 controller will send a pulse on the sync line issuing a warm reset. This will restart the AK4541 digital (resetting PR4 to zero). The AK4541 can also be woken up with a cold reset. A cold reset will cause a loss of values of the registers as a cold reset will set them to their default states. When a subsection is powered back on the Powerdown Control/Status register (index 26h) should be read to verify that the section is ready (i.e. stable) before attempting any operation that requires its normal operation.

And the below figure illustrates one example of procedure to do a complete powerdown/power up of AK4541.

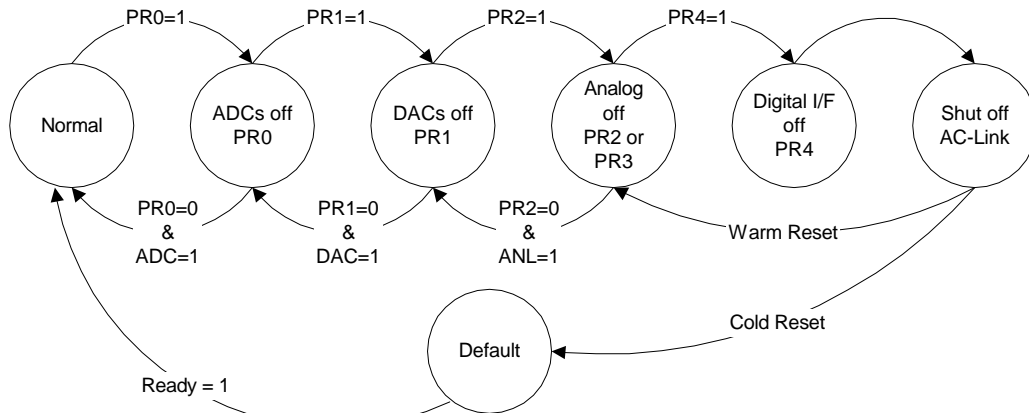

One example of AK4541 Powerdown/Powerup flow

When PR3 bit is set to "1", the ADC, DAC, Mixer, True Line Level Out, and VREF will be powered down even if any PRx bits are "0". When PR3 bit is reset to "0", the AK4541 resumes with the previous state by referencing PRx bit. In this case, the AK4541 outputs "0" (invalid) for corresponding slot-x valid bits in the slot 0 until the corresponding block of the AK4541 is operating with normal operation.

Setting the PR4 bit causes the Powerdown mode of AK4541 and AC-Link of AK4541 shut down. In this case, when Warm Reset is executed, PR4 bit is cleared and the AC-Link is reactivated. A cold reset is issued, the AK4541 is restored to operation with the default register settings.

In addition, setting PR5 bit causes the Powerdown mode of AK4541 and the internal clock of AK4541 to be stopped. When a warm reset is done in this case, PR5 bit is cleared to 0 and internal clock and AC-Link are reactivated.

When Cold reset is executed, AK4541 is set up to the operation with default register setting, no powerdown modes active.

The next figure illustrates a state when all the mixers should work with the static volume settings that are contained in their associated registers. This is used when the user is playing a CD (or external LINE\_IN source) through the AC '97 codec to the speakers but has most of the system in a low power mode. The procedure for this follows the previous except that the analog mixer is never shut down.

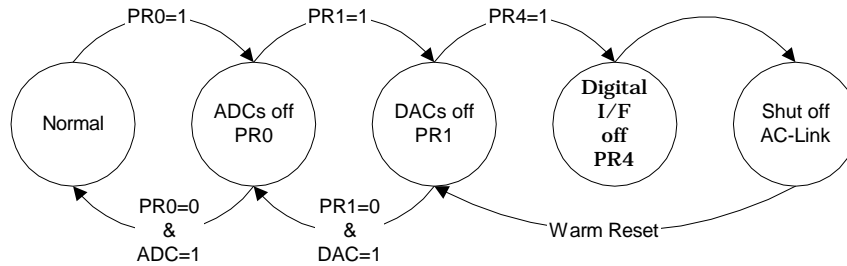

AK4541 Powerdown/Powerup flow with analog still alive

■ Powerdown/Powerup sequence of multiple codec configuration

There can be up to 4 Codecs on the extended AC-link. Multiple Codec AC-link implementations must run off a common BIT\_CLK. The Primary Codec generates the master AC-link BIT\_CLK for both the AC '97 Digital Controller and any Secondary Codecs. The AK4541 may be used as a master or slave in any systems using more than one codec.

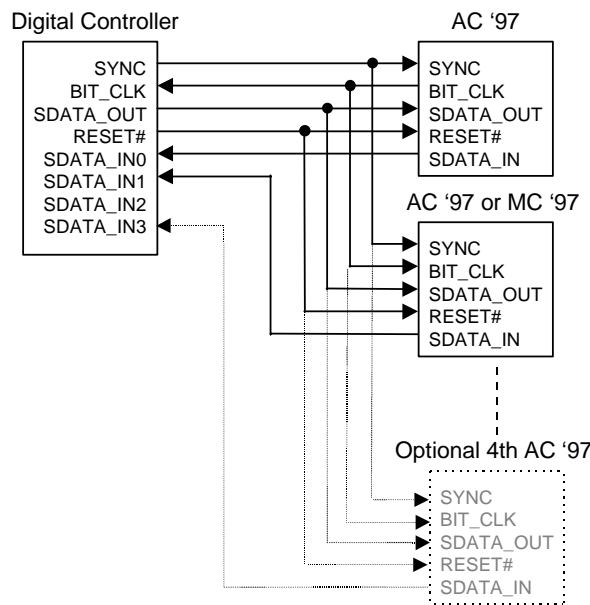

Multiple Codec Example

Under the multiple codec circumstances, there is no restriction on setting PR0(ADC), PR1(DAC), PR2(Mixer), PR6(LNLVL\_OUT) and PR7(EAPD) to "1" or "0".

As suggested in the AC'97 Specification Rev2.1, the AC-Link Powerdown(PR"4") and Vref Powerdown(PR5="1") under the Multiple codec configuration are NOT recommended in order to continue supplying BIT\_CLK to the Secondary codecs.

The below table shows the relationship for the AC-Link Powerdown/Powerup procedure.

AC-Link Powerdown Procedure	Subsequent Procedure for Powerup	Comments
RESET#=L	Cold Reset	Cold Reset wakes up all of codecs with default register setting concurrently.
Shutdown(Complete Powerdown)	Cold Reset	Cold Reset wakes up all of codecs with default register setting concurrently.

Note:

- 1) The AC-Link Powerdown of Primary AC'97 will stop supplying the BIT\_CLK to the Secondary AC'97.
- 2) When the AC-Link Powerdown is issued to the Secondary of AC'97, the Secondary of AC'97 will go to the AC-Link Powerdown and Warm Reset will be followed by Syn signal at the next time frame.

#### ■ Testability

##### Activating the Test Modes

AC '97 has two test modes. One is for ATE in circuit test and the other is for vendor specific tests. AC '97 enters the ATE in circuit test mode regardless of SYNC signal (high or low) if SDATA\_OUT is sampled high at the trailing edge of RESET#. If AC '97 enters AKM test mode when coming out of RESET if SYNC is high with SDATA\_OUT low. These cases will never occur during standard operating conditions.

Regardless of the test mode, the AC '97 controller must issue a "Cold" reset to resume normal operation of the AC '97 Codec.

##### Test Mode Functions

ATE in circuit test mode

When AC '97 is placed in the ATE test mode, its digital AC-link outputs (i.e. BIT\_CLK and SDATA\_IN) are driven to a high impedance state. This allows ATE in circuit testing of the AC '97 controller.

System Design

The following figure shows the system connection diagram.

Primary codec: codec ID1:codecID0=0:0  
AVDD: 3.3V  
DVDD: 3.3V

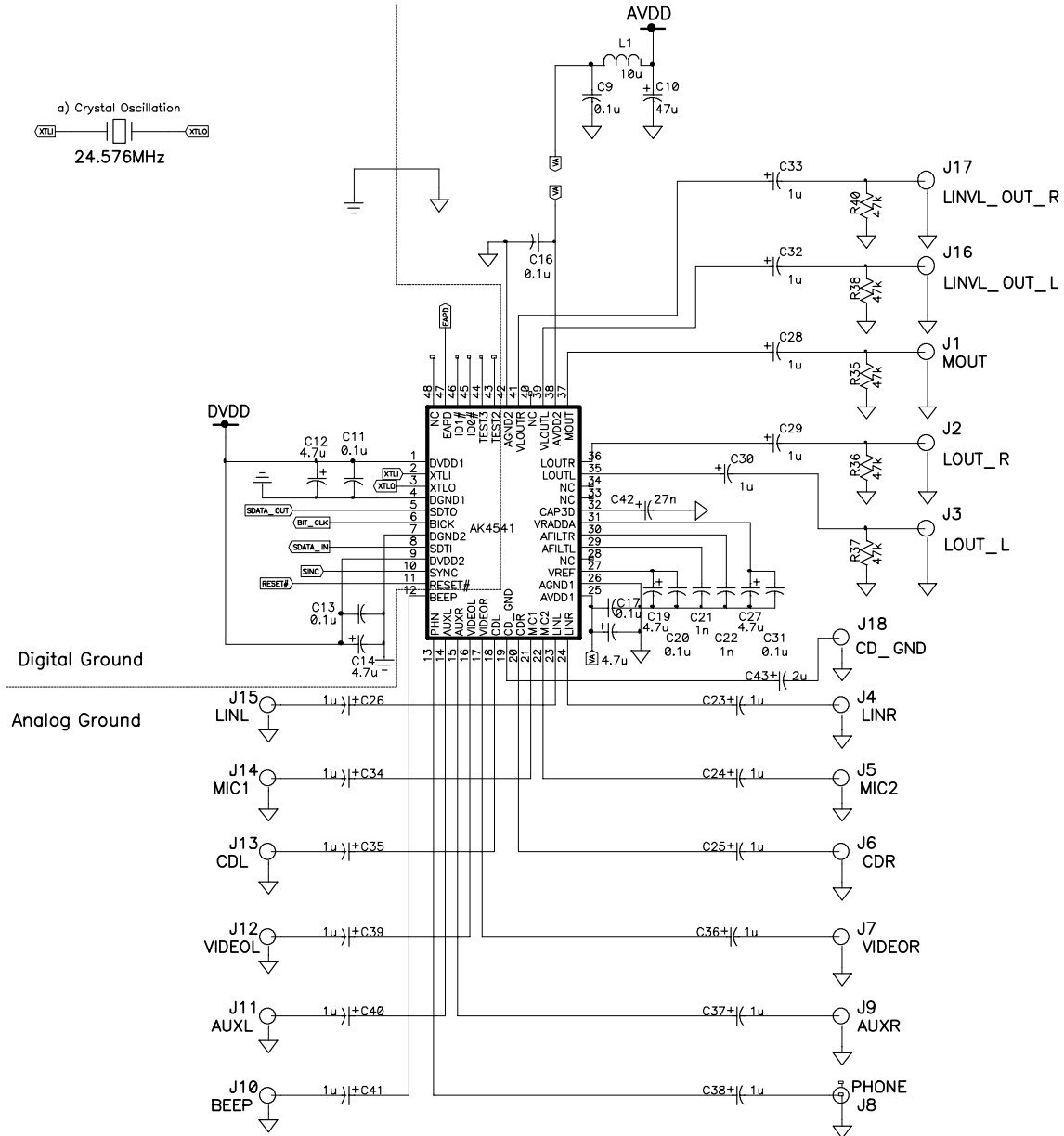

Secondary codec codec ID1:codecID0=0:1,1:0 or 1:1

This figure is the case of ID1 =0 and ID0=1.

AVDD: 3.3V

DVDD: 3.3V

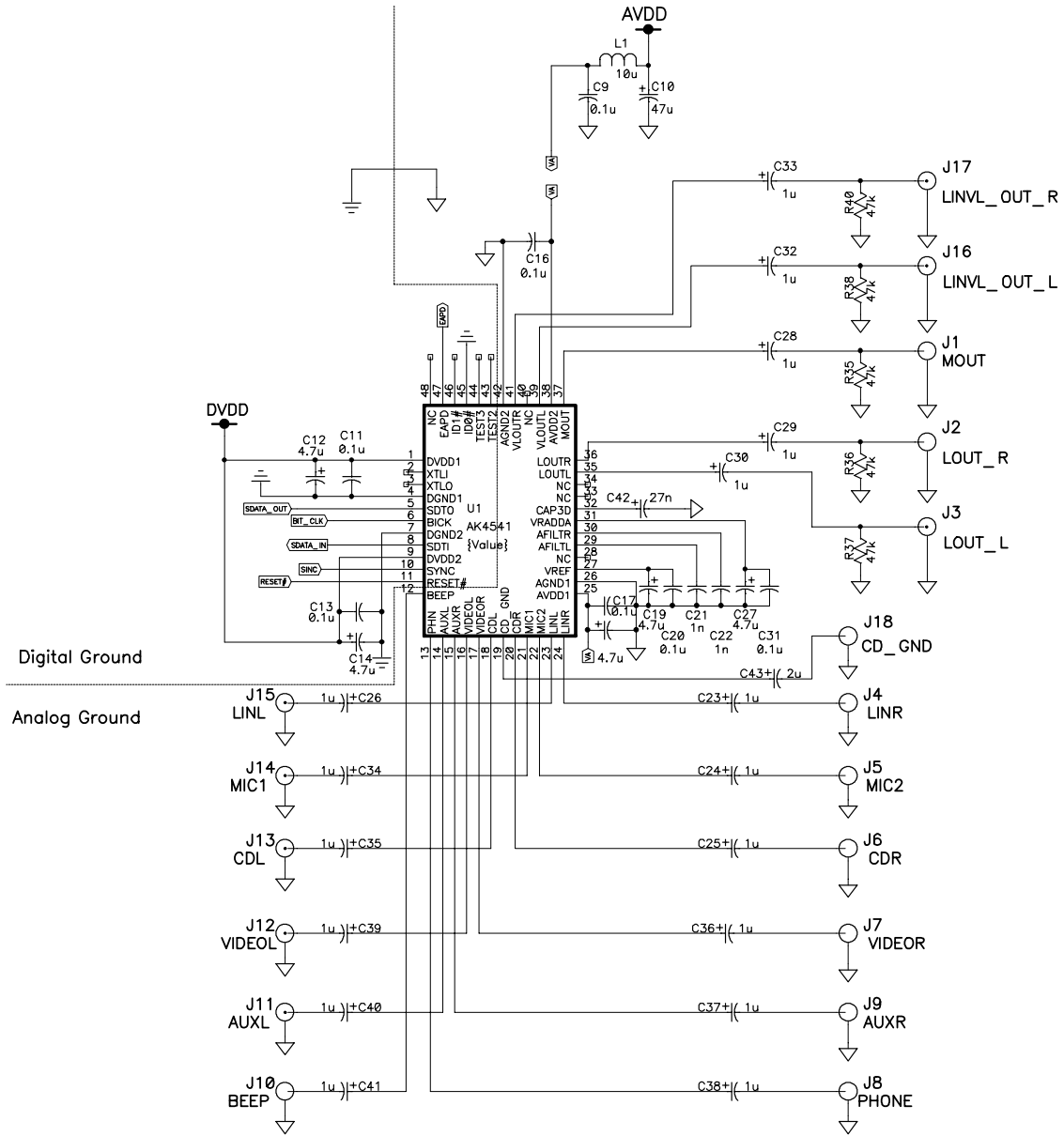

1. Grounding and Power Supply Decoupling

AVdd1 and AVdd2 should be connected and derived from same AVdd. And DVdd1 and DVdd2 also should be connected and derived from same DVdd. Analog ground and digital ground should be connected together near to where the supplies are brought onto the printed circuit board. Decoupling capacitors should be as near to the AK4541 as possible, with the small value ceramic capacitor being the nearest. The most important capacitor placements are on the Vref pin and AVdd pins.

No specific power supply sequencing is required on the AK4541.

2. On-chip Voltage Reference

The on-chip voltage reference is output on the VRADDA, Vref pins are used for decoupling. A electrolytic capacitor less than 10uF in parallel with a 0.1 uF ceramic capacitor attached to these pins eliminates the effects of high frequency noise. No load current may be drawn from VRADDA, or Vref pins. All signals, especially clocks, should be kept away from the VRADDA, and Vref pins in order to avoid unwanted coupling into delta-sigma modulators.

3. Codec ID configuration Pin 45,46

ID1#(pin 46)		ID0#(pin45)		Configuration
Physical Connection	Logic Value	Physical Connection	Logic Value	
NC	0	NC	0	Primary
NC	0	GND	1	Secondary ID01
GND	1	NC	0	Secondary ID10
GND	1	GND	1	Secondary ID11

4. Analog input

Since many analog levels can be as 1Vrms or 2Vrms, the circuit shown below can be used to attenuate the analog input 1Vrms or 2Vrms to 0.7Vrms which is the maximum voltage allowed for all the stereo line-level inputs.

a) 1Vrms input

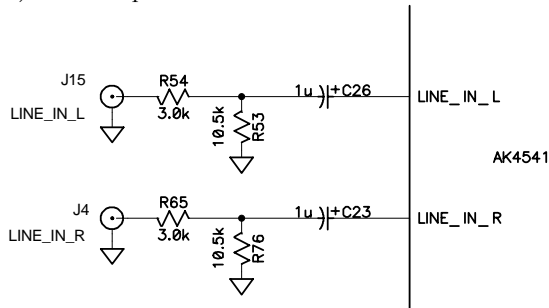

b) 2Vrms input

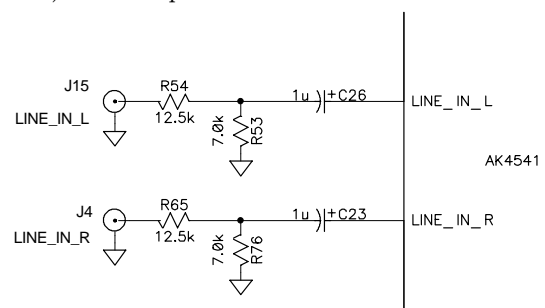

5. PC\_BEEP

If PC\_BEEP isn't used, this input pin should be NC(open) or connected to Analog-Ground via capacitor. In this case, the register for PC-Beep(04h,D15) should be set to mute on"1". (Note that the default of PC\_BEEP is mute off.)

In addition, when PC\_BEEP is connected through capacity to Analog-Ground, PC\_BEEP is recommended to be separated from other non-used input pins.

Package

48pin LQFP(Unit:mm)

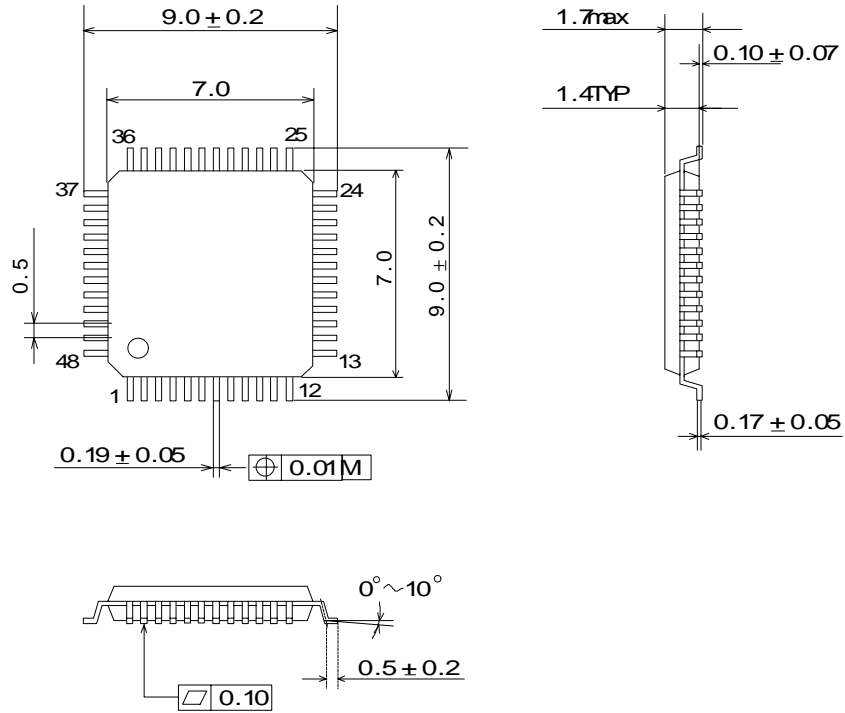

---

Marking

---

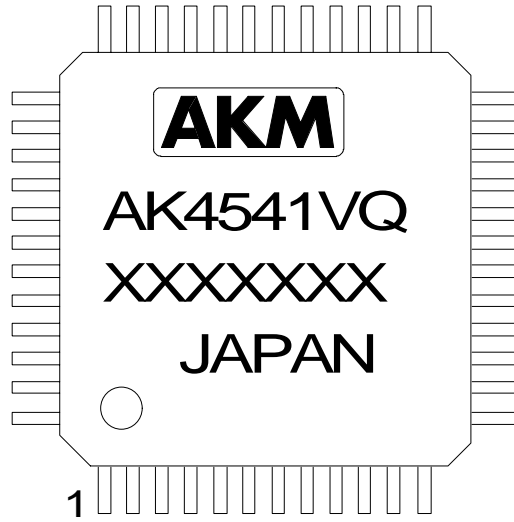

- 1) Pin #1 indication
- 2) Date Code : XXXXXXXX (7 digits)
- 3) Marketing Code : AK4541VQ
- 4) Country of Origin
- 5) Asahi Kasei Logo

<b>Appendix</b>
-----------------

## 1. Summary of the relationship of Slot 0 tag bit between SDATA\_OUT and SDATA\_IN

Whenever the AC '97 Digital Controller addresses the Primary AK4541 or the AK4541 responds to a read command, Slot 0 tag bits should always be set to indicate actual Slot 1 and Slot 2 data validity.

Function	Slot 0, bit 15 (Valid Frame)	Slot 0, bit 14 (Valid Slot 1 Address)	Slot 0, bit 13 (Valid Slot 2 Data)	Slot 0, Bits 1-0 (Codec ID)
AC'97 Digital Controller Primary Read Frame N, SDATA_OUT	1	1	0	00
AC'97 Digital Controller Primary Write Frame N, SDATA_OUT	1	1	1	00
AK4541 Status Frame N+1, SDATA_IN	1	1	1	00

Primary AK4541 Addressing: Slot 0 tag bits

When the AC '97 Digital Controller addresses a Secondary AK4541, the Slot 0 Tag bits for Address and Data must be "0". A non-zero 2-bit Codec ID in the LSBs of Slot 0 indicates a valid Read or Write Address in Slot 1, and the Slot 1 R/W bit indicates presence or absence of valid Data in Slot 2.

Function	Slot 0, bit 15 (Valid Frame)	Slot 0, bit 14 (Valid Slot 1 Address)	Slot 0, bit 13 (Valid Slot 2 Data)	Slot 0, Bits 1-0 (Codec ID)
AC'97 Digital Controller Secondary Read Frame N, SDATA_OUT	1	0	0	01, 10, or 11
AC'97 Digital Controller Secondary Write Frame N, SDATA_OUT	1	0	0	01, 10, or 11
AK4541 Status Frame N+1, SDATA_IN	1	1	1	00

Secondary AK4541 Addressing: Slot 0 tag bits

**IMPORTANT NOTICE**

- These products and their specifications are subject to change without notice. Before considering any use or application, consult the Asahi Kasei Microsystems Co., Ltd. (AKM) sales office or authorized distributor concerning their current status.
- AKM assumes no liability for infringement of any patent, intellectual property, or other right in the application or use of any information contained herein.
- Any export of these products, or devices or systems containing them, may require an export license or other official approval under the law and regulations of the country of export pertaining to customs and tariffs, currency exchange, or strategic materials.
- AKM products are neither intended nor authorized for use as critical components in any safety, life support, or other hazard related device or system, and AKM assumes no responsibility relating to any such use, except with the express written consent of the Representative Director of AKM. As used here:
  - (a) A hazard related device or system is one designed or intended for life support or maintenance of safety or for applications in medicine, aerospace, nuclear energy, or other fields, in which its failure to function or perform may reasonably be expected to result in loss of life or in significant injury or damage to person or property.
  - (b) A critical component is one whose failure to function or perform may reasonably be expected to result, whether directly or indirectly, in the loss of the safety or effectiveness of the device or system containing it, and which must therefore meet very high standards of performance and reliability.
- It is the responsibility of the buyer or distributor of an AKM product who distributes, disposes of, or otherwise places the product with a third party to notify that party in advance of the above content and conditions, and the buyer or distributor agrees to assume any and all responsibility and liability for and hold AKM harmless from any and all claims arising from the use of said product in the absence of such notification.

This datasheet has been downloaded from:

[www.DatasheetCatalog.com](http://www.DatasheetCatalog.com)

Datasheets for electronic components.



LittleDiode supplies new, hard to find or obsolete electronic components and semiconductors all over the world.

With over two million different components listed you are sure to find the part you need.

Feel free to visit us today at our online store:

[LittleDiode.com](http://LittleDiode.com)

Looking forward to providing you with the best possible service.