



### GENERAL DESCRIPTION

The AK4586 is a single chip CODEC that includes two channels of ADC and six channels of DAC. The ADC outputs 24bit data and the DAC accepts up to 24bit input data. The ADC has the Enhanced Dual Bit architecture with wide dynamic range. The DAC introduces the new developed Advanced Multi-Bit architecture, and achieves wider dynamic range and lower outband noise.

The AK4586 also has a digital audio receiver (DIR) compatible with 96kHz, 24bits. The AK4586 can automatically detect a Non-PCM bit stream. The digital audio output can be selected from the ADC output or the digital input. Control may be set directly by programmed through a separate serial interface.

The AK4586 has a dynamic range of 100dB for ADC, 106dB for DAC and is well suited for digital surround for home theater and car audio. The AK4586 also has the balance volume control corresponding to the AC-3 system. The AK4586 is available in a small 44pin LQFP package which will reduce system space.

\*AC-3 is a trademark of Dolby Laboratories.

### FEATURES

- 2ch 24bit ADC**
  - 64x Oversampling
  - Sampling Rate up to 96kHz
  - Linear Phase Digital Anti-Alias Filter
  - Single-Ended Input
  - S/(N+D): 90dB
  - Dynamic Range, S/N: 100dB
  - Digital HPF for offset cancellation
  - Overflow flag
- 6ch 24bit DAC**
  - 128x Oversampling
  - Sampling Rate up to 96kHz
  - 24bit 8 times Digital Filter
  - Single-Ended Outputs
  - On-chip Switched-Capacitor Filter
  - S/(N+D): 90dB
  - Dynamic Range, S/N: 106dB
  - Individual channel digital volume with 256 levels and 0.5dB step
  - Soft mute
  - Zero Detect Function
- 4 inputs 24bit DIR**
  - Supports IEC60958 consumer mode, S/PDIF, EIAJ CP1201 consumer mode
  - Low jitter Analog PLL
  - PLL Lock Range: 32k ~ 96kHz
  - Clock Source: PLL or X'tal
  - 4 channel Receivers input and 1 through transmission output
  - De-emphasis for 32kHz, 44.1kHz and 48kHz
  - Dedicated Detect Pins
    - Non-PCM Bit Stream Detect, DTS-CD Bit Stream Detect,
    - Validity Flag Detect, 96kHz Sampling Detect,
    - Unlock & Parity Error Detect, Emphasis Detect, fs change Detect
  - Supports up to 24bit Audio Data Format
  - Audio I/F: Master or Slave Mode
  - 32bits Channel Status Buffer

- Burst Preamble bit Pc, Pd Buffer for Non-PCM bit stream
- Master Clock Outputs: 128fs/256fs/512fs
- I/F format: MSB justified, LSB justified(20bit,24bit), I<sup>2</sup>S or TDM
- High Jitter Tolerance
- TTL Level Digital I/F
- 4-wire Serial and I<sup>2</sup>C Bus  $\mu$ P I/F for mode setting
- External Master Clock Input:
  - 256fs, 384fs or 512fs for fs=44.1kHz to 48kHz
  - 128fs, 192fs or 256fs for fs=88.2kHz to 96kHz
- Power Supply: 4.5 to 5.5V
- Power Supply for output buffer: 2.7 to 5.5V
- Small 44pin LQFP

■ Block Diagram

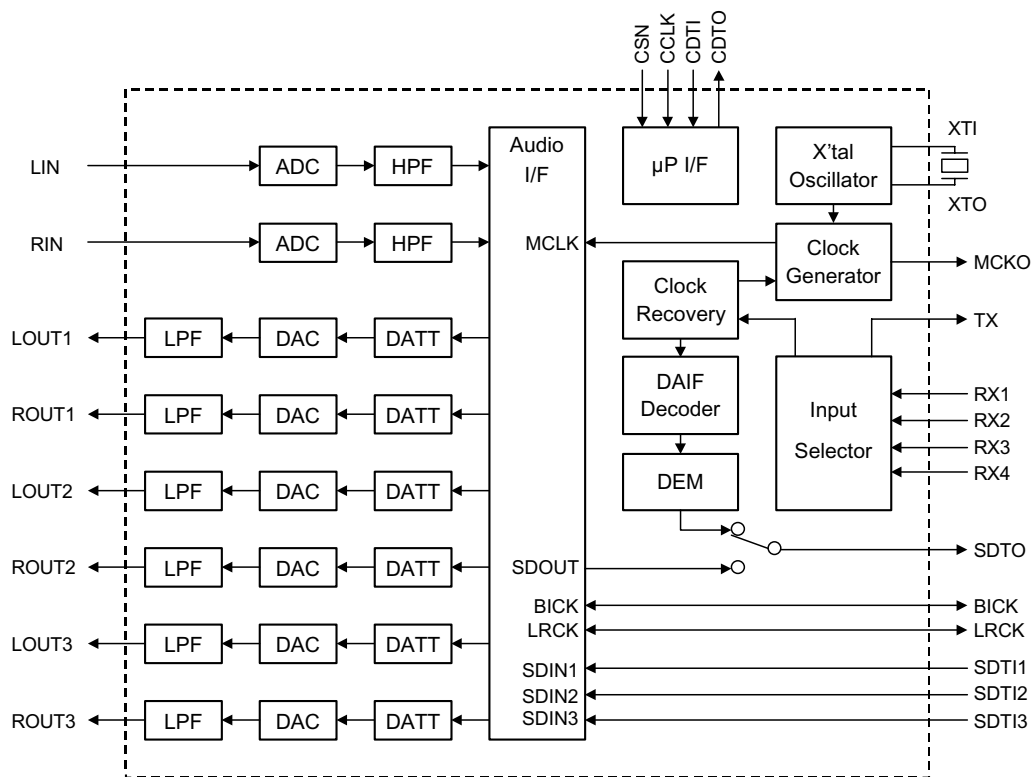

■ Ordering Guide

AK4586VQ  
AKD4586

-40 ~ +85°C  
Evaluation Board for AK4586

44pin LQFP(0.8mm pitch)

■ Pin Layout

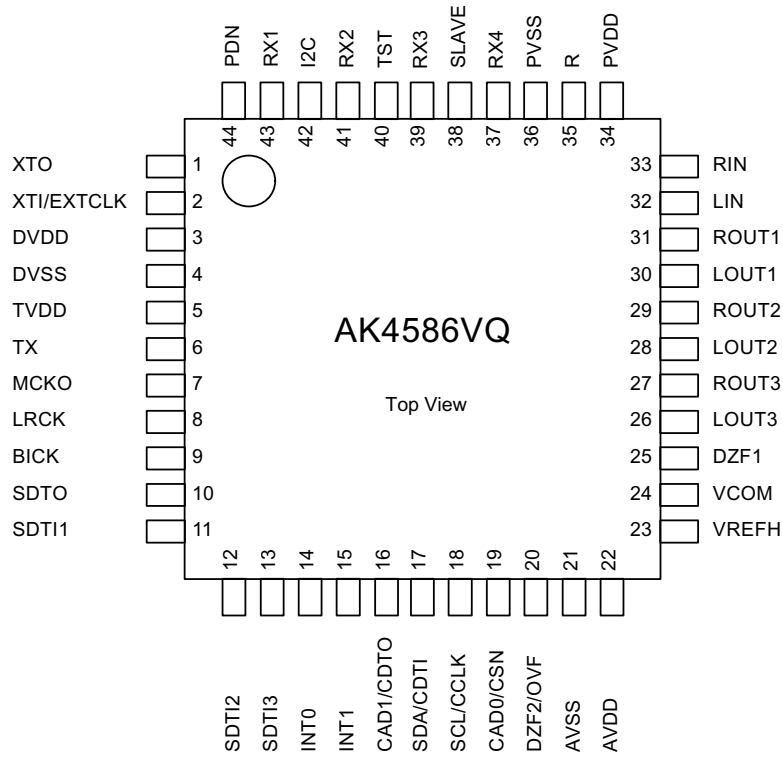

### ■ Compatibility with AK4527B/29

Functions	AK4527B/29	AK4586
ADC S/(N+D)	92dB	90dB
ADC Dynamic Range, S/N	102dB	100dB
DAC channel	6ch/8ch	6ch
Master mode	Not available	Available
Parallel mode	Available	Not available
Read operation for internal register	Not available	Available
Chip address at 4-wire serial mode	2bit selectable	fixed to "00"

### ■ Compatibility with AK4112A

Functions	AK4112A	AK4586
Power supply	2.7 ~ 3.6V	4.5 ~ 5.5V
Rock range	22k ~ 108kHz	32k ~ 96kHz
Master clock output	2 pins	1 pin
External master clock input	256fs/512fs	256fs/384fs/512fs for Normal speed 128fs/192fs/256fs for Double speed
Detect pins	4 pins	2 pins
DTS-CDdetect	Not available	Available
CRC	Available	Not available
Parallel mode	Available	Not available
I <sup>2</sup> C bus mode	Not available	Available
Digital input level	CMOS	TTL

PIN/FUNCTION			
No.	Pin Name	I/O	Function
1	XTO	O	X'tal Output Pin
2	XTI	I	X'tal Input Pin
	EXTCLK	I	External Master Clock Input Pin
3	DVDD	-	Digital Power Supply Pin, 4.5V~5.5V
4	DVSS	-	Digital Ground Pin, 0V
5	TVDD	-	Output Buffer Power Supply Pin, 2.7V~5.5V
6	TX	O	Transmit channel (through data) Output Pin
7	MCKO	O	Master Clock Output Pin
8	LRCK	I/O	Input/Output Channel Clock Pin
9	BICK	I/O	Audio Serial Data Clock Pin
10	SDTO	O	Audio Serial Data Output Pin
11	SDTI1	I	DAC1 Audio Serial Data Input Pin
12	SDTI2	I	DAC2 Audio Serial Data Input Pin
13	SDTI3	I	DAC3 Audio Serial Data Input Pin
14	INT0	O	Interrupt 0 pin
15	INT1	O	Interrupt 1 pin
16	CDTO	O	Control Data Output Pin in 4-wire serial control mode
	CAD1	I	Chip Address 1 Pin in I <sup>2</sup> C bus control mode
17	CDTI	I	Control Data Input Pin in 4-wire serial control mode
	SDA	I/O	Control Data Input/Output Pin in I <sup>2</sup> C bus control mode
18	CCLK	I	Control Data Clock Pin in 4-wire serial control mode
	SCL	I	Control Data Clock Pin in I <sup>2</sup> C bus control mode
19	CSN	I	Chip Select Pin in 4-wire serial control mode
	CAD0	I	Chip Address 0 Pin in I <sup>2</sup> C bus control mode
20	DZF2	O	Zero Input Detect 2 Pin (Note 1) When the input data of the group 1 follow total 8192 LRCK cycles with "0" input data, this pin goes to "H".
	OVF	O	Analog Input Overflow Detect Pin (Note 2) This pin goes to "H" if the analog input of Lch or Rch is overflows.
21	AVSS	-	Analog Ground Pin, 0V
22	AVDD	-	Analog Power Supply Pin, 4.5V~5.5V

No.	Pin Name	I/O	Function
23	VREFH	I	Positive Voltage Reference Input Pin, AVDD
24	VCOM	O	Common Voltage Output Pin, AVDD/2 Large external capacitor around 2.2 $\mu$ F is used to reduce power-supply noise.
25	DZF1	O	Zero Input Detect 1 Pin (Note 1) When the input data of the group 1 follow total 8192 LRCK cycles with "0" input data, this pin goes to "H".
26	LOUT3	O	DAC3 Lch Analog Output Pin
27	ROUT3	O	DAC3 Rch Analog Output Pin
28	LOUT2	O	DAC2 Lch Analog Output Pin
29	ROUT2	O	DAC2 Rch Analog Output Pin
30	LOUT1	O	DAC1 Lch Analog Output Pin
31	ROUT1	O	DAC1 Rch Analog Output Pin
32	LIN	I	Lch Analog Input Pin
33	RIN	I	Rch Analog Input Pin
34	PVDD	-	PLL Power Supply Pin, 4.5V~5.5V
35	R	-	External Resistor Pin 18k $\Omega$ +/-1% resistor to PVSS externally.
36	PVSS	-	PLL Ground Pin, 0V
37	RX4	I	Receiver Channel 4 Pin (Internal biased pin)
38	SLAVE	I	Slave Mode Pin "L": Master mode or Slave mode, "H": Slave mode
39	RX3	I	Receiver Channel 3 Pin (Internal biased pin)
40	TST	I	Test Pin This pin should be connected to DVSS.
41	RX2	I	Receiver Channel 2 Pin (Internal biased pin)
42	I2C	I	Control Mode Select Pin "L": 4-wire Serial, "H": I <sup>2</sup> C Bus
43	RX1	I	Receiver Channel 1 Pin (Internal biased pin)
44	PDN	I	Power-Down & Reset Pin When "L", the AK4586 is powered-down, all output pins go to "L" and the control registers are reset to default state. If the state of CAD1-0 changes, then the AK4586 must be reset by PDN.

## Notes:

1. The group 1 and 2 can be selected by DZFM2-0 bits.
2. This pin becomes OVF pin if OVFE bit is set to "1".
3. All input pins except internal biased pins should not be left floating.

**ABSOLUTE MAXIMUM RATINGS**

(AVSS, DVSS, PVSS=0V; Note 4)

Parameter		Symbol	min	max	Units
Power Supplies	Analog	AVDD	-0.3	6.0	V
	Digital	DVDD	-0.3	6.0	V
	PLL	PVDD	-0.3	6.0	V
	Output buffer	TVDD	-0.3	6.0	V
	AVSS-DVSS  (Note 5)	$\Delta$ GNDD1	-	0.3	V
	AVSS-PVSS  (Note 5)	$\Delta$ GNDD2	-	0.3	V
Input Current (any pins except for supplies)		IIN	-	$\pm$ 10	mA
Analog Input Voltage		VINA	-0.3	AVDD+0.3	V
Digital Input Voltage (XTI/EXTCLK, SDTI1-3, CDTI/SDA, CCLK/SCL, CSN/CAD0 pins)		VIND1	-0.3	DVDD+0.3	V
(LRCK, BICK, CDTO/CAD1 pins)		VIND2	-0.3	TVDD+0.3	V
(RX1-4, SLAVE, TST, I2C, PDN pins)		VIND3	-0.3	PVDD+0.3	V
Ambient Temperature (power applied)		Ta	-40	85	°C
Storage Temperature		Tstg	-65	150	°C

Notes:

4. All voltages with respect to ground.
5. AVSS, DVSS and PVSS must be connected to the same analog ground plane.

WARNING: Operation at or beyond these limits may result in permanent damage to the device.  
Normal operation is not guaranteed at these extremes.

**RECOMMENDED OPERATING CONDITIONS**

(AVSS, DVSS, PVSS=0V; Note 4)

Parameter		Symbol	min	typ	max	Units
Power Supplies (Note 6)	Analog	AVDD	4.5	5.0	5.5	V
	Digital	DVDD	4.5	5.0	5.5	V
	PLL	PVDD	4.5	5.0	5.5	V
	Output buffer	TVDD	2.7	5.0	5.5	V

Notes:

4. All voltages with respect to ground.
6. The power up sequence between AVDD, DVDD, PVDD and TVDD is not critical.

WARNING: AKM assumes no responsibility for the usage beyond the conditions in this datasheet.

<b>ANALOG CHARACTERISTICS</b>
-------------------------------

(Ta=25°C; AVDD, DVDD, PVDD, TVDD=5V; AVSS, DVSS=0V; VREFH=AVDD; fs=48kHz; BICK=64fs; Signal Frequency=1kHz; 24bit Data; Measurement Frequency=20Hz~20kHz at fs=48kHz, 20Hz~40kHz at fs=96kHz; unless otherwise specified)

Parameter	min	typ	max	Units
<b>ADC Analog Input Characteristics</b>				
Resolution			24	Bits
S/(N+D) (-0.5dBFS)	fs=48kHz	82	90	dB
	fs=96kHz	78	86	dB
DR (-60dBFS)	fs=48kHz, A-weighted	92	100	dB
	fs=96kHz, A-weighted	91	100	dB
S/N (Note 7)	fs=48kHz, A-weighted	92	100	dB
	fs=96kHz, A-weighted	91	100	dB
Interchannel Isolation		90	110	dB
<b>DC Accuracy</b>				
Interchannel Gain Mismatch		0.2	0.3	dB
Gain Drift		20	-	ppm/°C
Input Voltage	fs=48kHz AIN=0.62xVREFH	2.90	3.10	Vpp
	fs=96kHz AIN=0.65xVREFH	3.05	3.25	Vpp
Input Resistance (Note 8)		15	25	kΩ
Power Supply Rejection (Note 9)			50	dB
<b>DAC Analog Output Characteristics</b>				
Resolution			24	Bits
S/(N+D)	fs=48kHz	80	90	dB
	fs=96kHz	78	86	dB
DR (-60dBFS)	fs=48kHz, A-weighted	95	106	dB
	fs=96kHz, A-weighted	94	106	dB
S/N (Note 10)	fs=48kHz, A-weighted	95	106	dB
	fs=96kHz, A-weighted	94	106	dB
Interchannel Isolation		90	110	dB
<b>DC Accuracy</b>				
Interchannel Gain Mismatch		0.2	0.5	dB
Gain Drift		20	-	ppm/°C
Output Voltage AOUT=0.6xVREFH		2.75	3.0	Vpp
Load Resistance		5		kΩ
Power Supply Rejection (Note 9)			50	dB
<b>Power Supplies</b>				
Power Supply Current				
Normal Operation (PDN = "H") (Note 11)				
AVDD			39	mA
PVDD			9	mA
DVDD+TVDD fs=48kHz (Note 12)			28	mA
fs=96kHz			39	mA
Power-down mode (PDN = "L") (Note 13)			80	μA

## Notes:

7. S/N measured by CCIR-ARM is 96dB(@fs=48kHz).
8. Input resistance is 16kΩ typically at fs=96kHz.
9. PSR is applied to AVDD, DVDD, PVDD and TVDD with 1kHz, 50mVpp. VREFH pin is held a constant voltage.
10. S/N measured by CCIR-ARM is 102dB(@fs=48kHz).
11. CL=20pF, X'tal=24.576MHz, CM1-0= "10", OCKS= "10".
12. TVDD=3mA(typ).
13. In the power-down mode. RX inputs are open and all digital input pins including clock pins (MCLK, BICK, LRCK) are held DVSS.

FILTER CHARACTERISTICS							
(Ta=25°C; AVDD, DVDD, PVDD=4.5~5.5V; TVDD=2.7~5.5V; fs=48kHz)							
Parameter	Symbol	min	typ	max	Units		
<b>ADC Digital Filter (Decimation LPF):</b>							
Passband (Note 14)		±0.1dB	PB	0		18.9	kHz
		-0.2dB		-	20.0	-	kHz
		-3.0dB		-	23.0	-	kHz
Stopband	SB	29.4					kHz
Passband Ripple	PR				±0.1		dB
Stopband Attenuation	SA	65					dB
Group Delay (Note 15)	GD			17.0			1/fs
Group Delay Distortion	ΔGD			0			μs
<b>ADC Digital Filter (HPF):</b>							
Frequency Response (Note 14)		-3dB	FR		1.0		Hz
		-0.1dB			6.5		Hz
<b>DAC Digital Filter:</b>							
Passband (Note 14)		-0.1dB	PB	0		21.8	kHz
		-6.0dB		-	24.0	-	kHz
Stopband	SB	26.2					kHz
Passband Ripple	PR				±0.02		dB
Stopband Attenuation	SA	54					dB
Group Delay (Note 15)	GD			19.1			1/fs
<b>DAC Digital Filter + Analog Filter:</b>							
Frequency Response:		0 ~ 20.0kHz	FR		±0.2		dB
		40.0kHz (Note 16)	FR		±0.3		dB

## Notes:

14. The passband and stopband frequencies scale with fs.  
For example, 21.8kHz at -0.1dB is 0.454 x fs. The reference frequency of these responses is 1kHz.
15. The calculating delay time which occurred by digital filtering. This time is from setting the input of analog signal to setting the 24bit data of both channels to the output register for ADC.  
For DAC, this time is from setting the 20/24bit data of both channels on input register to the output of analog signal.
16. fs=96kHz.

DC CHARACTERISTICS						
(Ta=25°C; AVDD, DVDD, PVDD=4.5~5.5V; TVDD=2.7~5.5V)						
Parameter	Symbol	min	typ	max	Units	
High-Level Input Voltage (Except XTI pin)	VIH	2.2	-	-	V	
	(XTI pin)	VIH	70%DVDD	-	-	V
Low-Level Input Voltage (Except XTI pin)	VIL	-	-	0.8	V	
	(XTI pin)	VIL	-	30%DVDD	V	
Input Voltage at AC Coupling (Note 17)	VAC	40%DVDD	-	-	Vpp	
High-Level Output Voltage (Except TX, DZF1, DZF2/OVF pins: Iout=-400μA)	VOH	TVDD-0.5	-	-	V	
	(TX pin: Iout=-400μA)	VOH	DVDD-0.5	-	-	V
	(DZF1, DZF2/OVF pins: Iout=-400μA)	VOH	AVDD-0.5	-	-	V
Low-Level Output Voltage (Except SDA pin: Iout= 400μA)	VOL	-	-	0.5	V	
	(SDA pin: Iout= 3mA)	VOL	-	0.4	V	
Input Leakage Current	Iin	-	-	±10	μA	

## Notes:

17. In case of connecting capacitance to XTI pin (refer to Figure 4).

<b>SWITCHING CHARACTERISTICS</b>
----------------------------------

(Ta=25°C; AVDD, DVDD, PVDD=4.5~5.5V; TVDD=2.7~5.5V; CL=20pF)

Parameter	Symbol	min	typ	max	Units
<b>Master Clock Timing</b>					
<b>Crystal Resonator</b>					
Frequency	fXTAL	11.2896		24.576	MHz
<b>External Clock</b>					
256fsn, 128fsd:	fCLK	11.2896		12.288	MHz
Pulse Width Low	tCLKL	27			ns
Pulse Width High	tCLKH	27			ns
384fsn, 192fsd:	fCLK	16.9344		18.432	MHz
Pulse Width Low	tCLKL	20			ns
Pulse Width High	tCLKH	20			ns
512fsn, 256fsd:	fCLK	22.5792		24.576	MHz
Pulse Width Low	tCLKL	15			ns
Pulse Width High	tCLKH	15			ns
<b>MCKO output</b>					
Frequency	fMCK	5.6448		24.576	MHz
Duty (Note 18)	dMCK	40	50	60	%
PLL Clock Recover Frequency	fPLL	32		96	kHz
<b>LRCK Timing</b>					
<b>TDM= "0"</b>					
LRCK frequency Normal Speed Mode	fsn	32		48	kHz
LRCK frequency Double Speed Mode	fsd	88.2		96	kHz
Duty Cycle	Duty	45		55	%
<b>TDM= "1" (Slave mode)</b>					
LRCK frequency	fsn	32		48	kHz
"H" time	tLRH	1/256fs			ns
"L" time	tLRL	1/256fs			ns
<b>TDM= "1" (Master mode)</b>					
LRCK frequency	fsn	32		48	kHz
"H" time (Note 19)	tLRH		1/8fs		ns

## Notes:

18. Except the case CLKDIV= "0" for the external clock input. CL=15pF when MCKO is above 22.5792MHz.

19. "L" time at I<sup>2</sup>S format.

Parameter	Symbol	min	typ	max	Units
<b>Audio Interface Timing (Slave mode)</b>					
<b>TDM= "0"</b>					
BICK Period	tBCK	160			ns
BICK Pulse Width Low	tBCKL	65			ns
Pulse Width High	tBCKH	65			ns
LRCK Edge to BICK "↑" (Note 20)	tLRB	45			ns
BICK "↑" to LRCK Edge (Note 20)	tBLR	45			ns
LRCK to SDTO(MSB) (Note 21)	tLRS			40	ns
BICK "↓" to SDTO	tBSD			40	ns
SDTI1-3, DAUX Hold Time	tSDH	40			ns
SDTI1-3, DAUX Setup Time	tSDS	25			ns
<b>TDM= "1"</b>					
BICK Period	tBCK	81			ns
BICK Pulse Width Low	tBCKL	32			ns
Pulse Width High	tBCKH	32			ns
LRCK Edge to BICK "↑" (Note 20)	tLRB	20			ns
BICK "↑" to LRCK Edge (Note 20)	tBLR	20			ns
BICK "↓" to SDTO	tBSD			20	ns
SDTI1 Hold Time	tSDH	10			ns
SDTI1 Setup Time	tSDS	10			ns
<b>Audio Interface Timing (Master mode)</b>					
<b>TDM= "0"</b>					
BICK Frequency	fBCK		64fs		Hz
BICK Duty	dBCK		50		%
BICK "↓" to LRCK Edge	tMBLR	-20		20	ns
BICK "↓" to SDTO	tBSD			40	ns
SDTI1-3 Hold Time	tSDH	40			ns
SDTI1-3 Setup Time	tSDS	25			ns
<b>TDM= "1"</b>					
BICK Frequency	fBCK		256fs		Hz
BICK Duty	dBCK		50		%
BICK "↓" to LRCK Edge	tMBLR	-12		12	ns
BICK "↓" to SDTO	tBSD			20	ns
SDTI1 Hold Time	tSDH	10			ns
SDTI1 Setup Time	tSDS	10			ns

## Notes:

20. BICK rising edge must not occur at the same time as LRCK edge.

21. MSB justified format.

Parameter	Symbol	min	typ	max	Units
<b>Control Interface Timing (3-wire Serial mode):</b>					
CCLK Period	tCCK	200			ns
CCLK Pulse Width Low	tCCKL	80			ns
Pulse Width High	tCCKH	80			ns
CDTI Setup Time	tCDS	40			ns
CDTI Hold Time	tCDH	40			ns
CSN "H" Time	tCSW	150			ns
CSN "↓" to CCLK "↑"	tCSS	50			ns
CCLK "↑" to CSN "↑"	tCSH	50			ns
CDTO Delay	tDCD			45	ns
CSN "↑" to CDTO Hi-Z	tCCZ			70	ns
<b>Control Interface Timing (I<sup>2</sup>C Bus mode):</b>					
SCL Clock Frequency	fSCL	-		100	kHz
Bus Free Time Between Transmissions	tBUF	4.7		-	μs
Start Condition Hold Time (prior to first clock pulse)	tHD:STA	4.0		-	μs
Clock Low Time	tLOW	4.7		-	μs
Clock High Time	tHIGH	4.0		-	μs
Setup Time for Repeated Start Condition	tSU:STA	4.7		-	μs
SDA Hold Time from SCL Falling (Note 22)	tHD:DAT	0		-	μs
SDA Setup Time from SCL Rising	tSU:DAT	0.25		-	μs
Rise Time of Both SDA and SCL Lines	tR	-		1.0	μs
Fall Time of Both SDA and SCL Lines	tF	-		0.3	μs
Setup Time for Stop Condition	tSU:STO	4.0		-	μs
Pulse Width of Spike Noise Suppressed by Input Filter	tSP	0		50	ns
<b>Power-down &amp; Reset Timing</b>					
PDN Pulse Width (Note 23)	tPD	150			ns
PDN "↑" to SDTO valid (Note 24)	tPDV		522		1/fs

## Notes:

22. Data must be held for sufficient time to bridge the 300 ns transition time of SCL.  
 23. The AK4586 can be reset by bringing PDN "L" to "H" upon power-up.  
 24. These cycles are the number of LRCK rising from PDN rising.  
 25. I<sup>2</sup>C is a registered trademark of Philips Semiconductors.

Purchase of Asahi Kasei Microsystems Co., Ltd I<sup>2</sup>C components conveys a license under the Philips I<sup>2</sup>C patent to use the components in the I<sup>2</sup>C system, provided the system conform to the I<sup>2</sup>C specifications defined by Philips.

### S/PDIF RECEIVER CHARACTERISTICS

(Ta=25°C; AVDD, DVDD, PVDD=4.5~5.5V; TVDD=2.7~5.5V)

Parameter	Symbol	min	typ	max	Units
Input Resistance	Zin		10		kΩ
Input Voltage	VTH	200			mVpp
Input Hysteresis	VHY	-	50		mV
Input Sample Frequency	fs	32	-	96	kHz

■ Timing Diagram

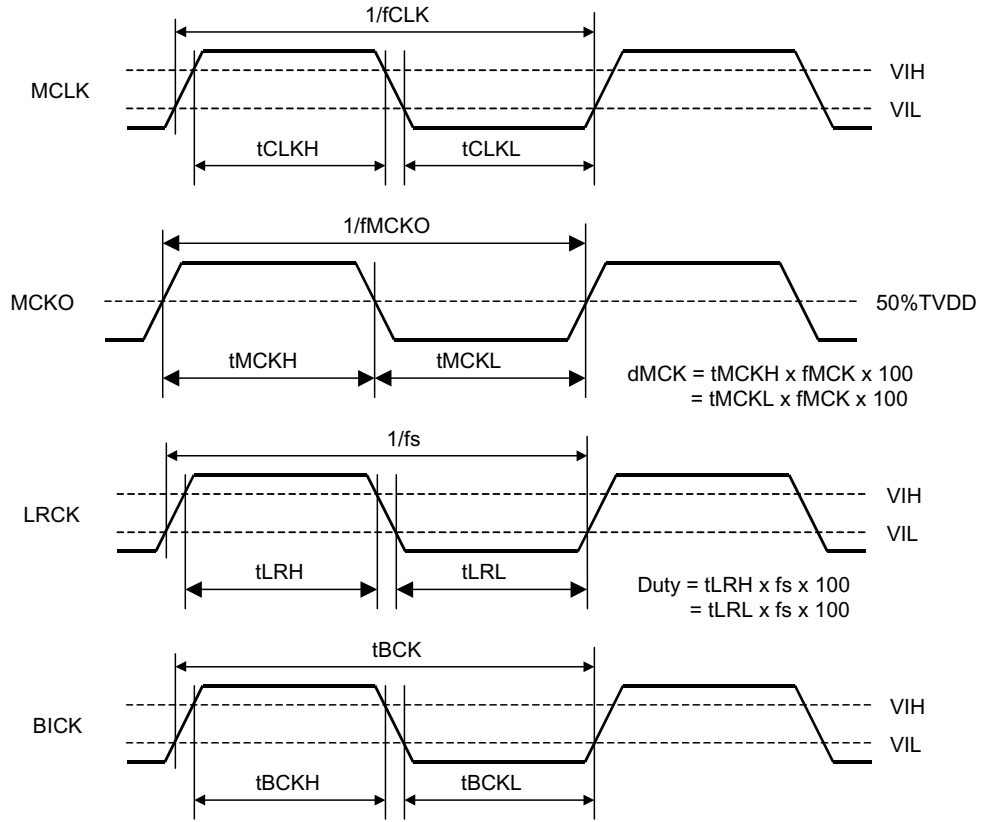

Clock Timing (TDM= "0")

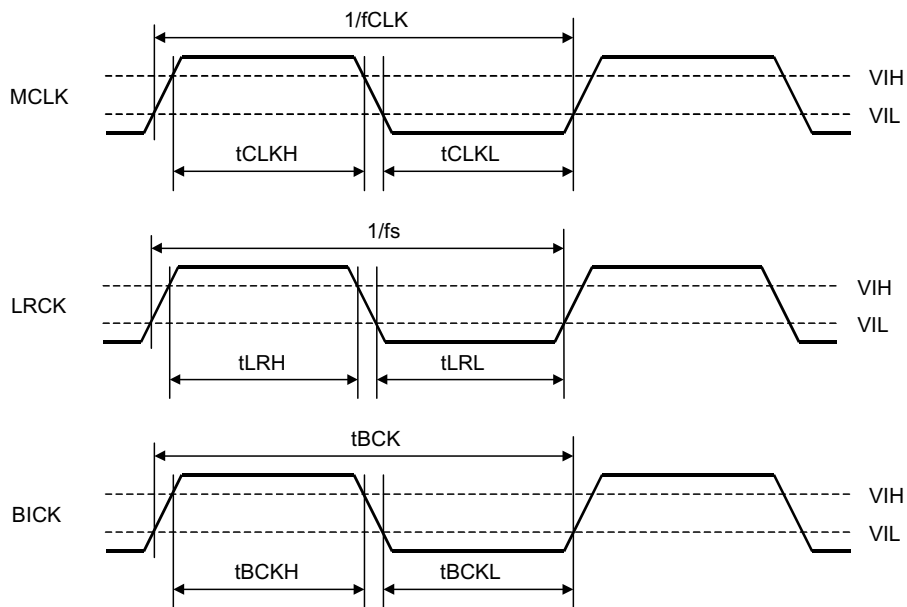

Clock Timing (TDM= "1")

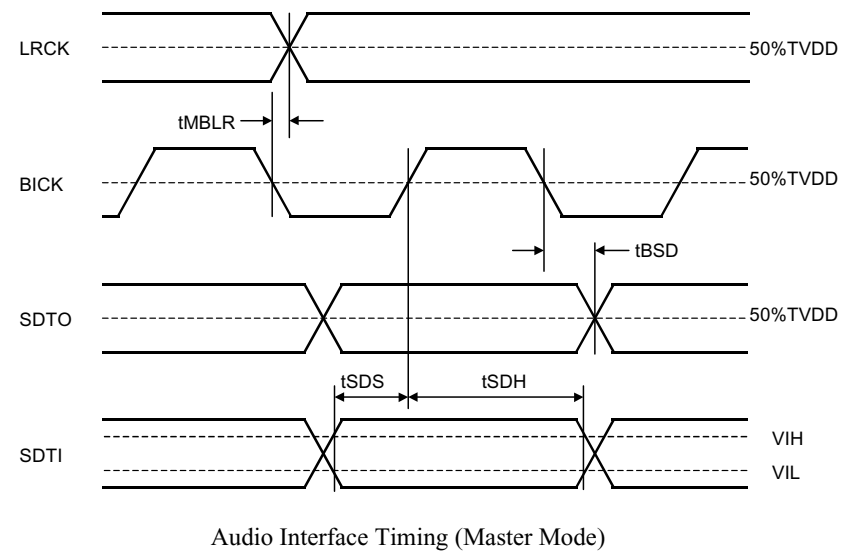
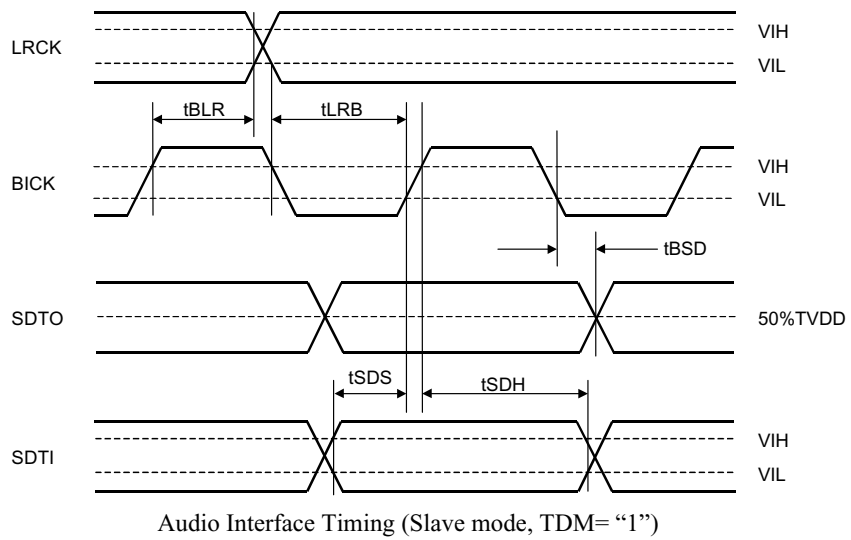
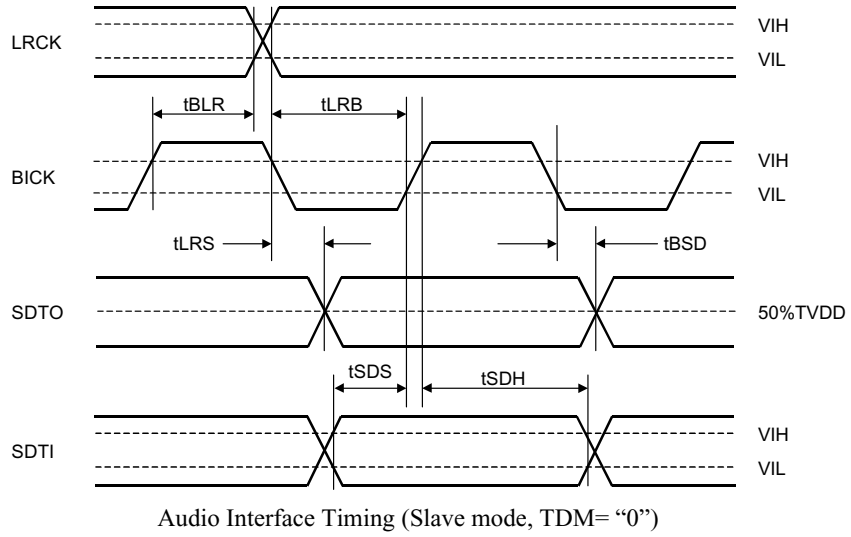

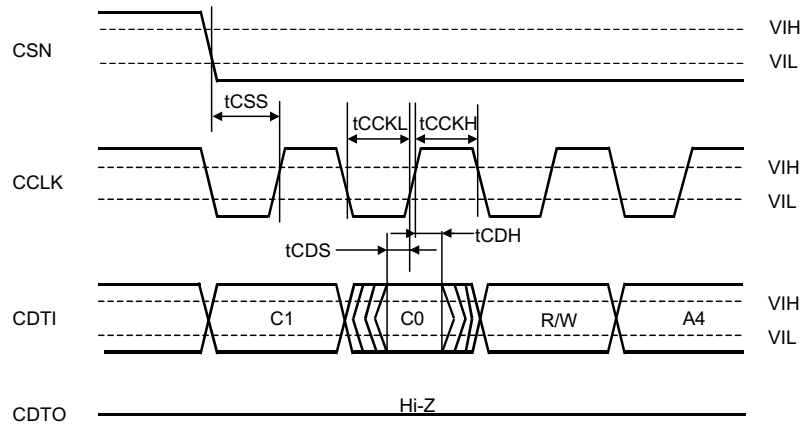

WRITE/READ Command Input Timing (4-wire serial mode)

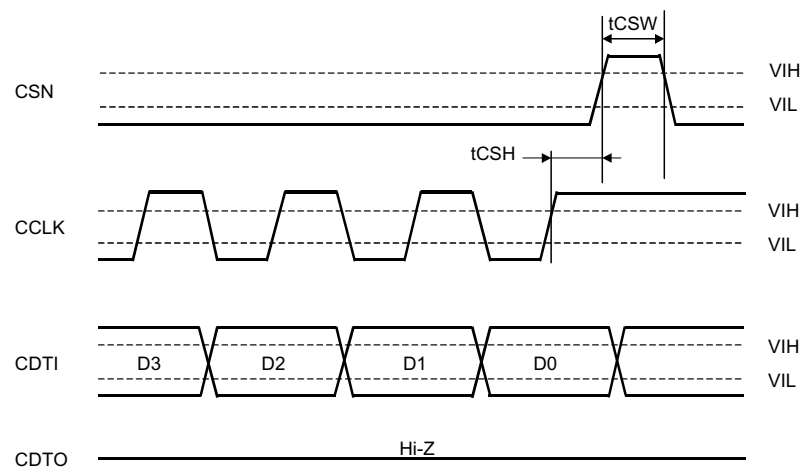

WRITE Data Input Timing (4-wire serial mode)

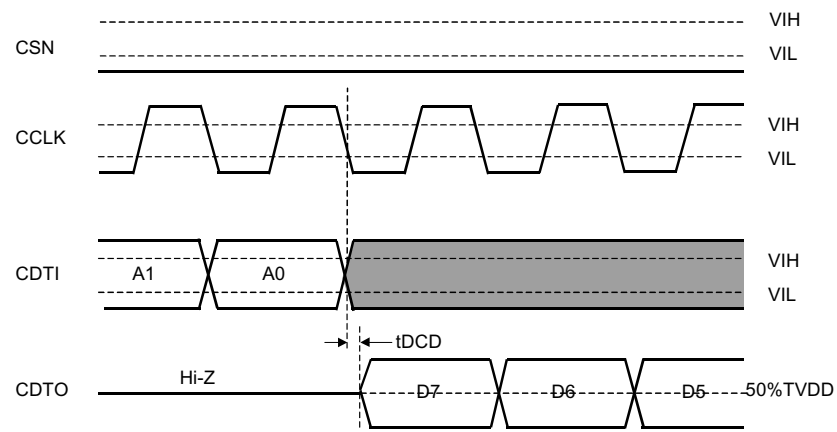

READ Data Output Timing 1 (4-wire serial mode)

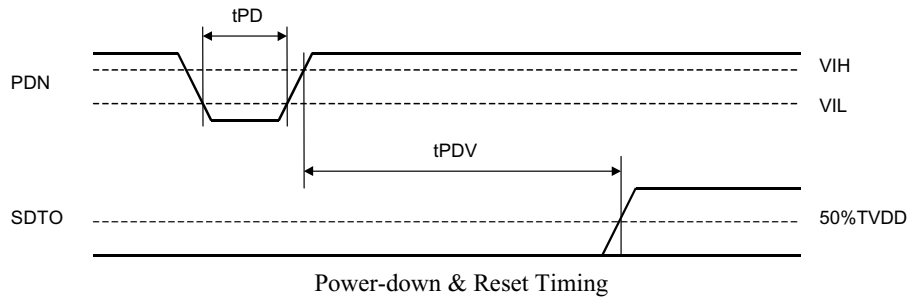
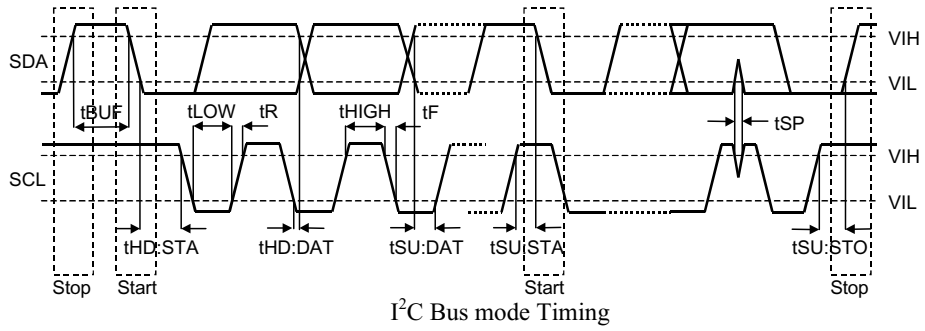
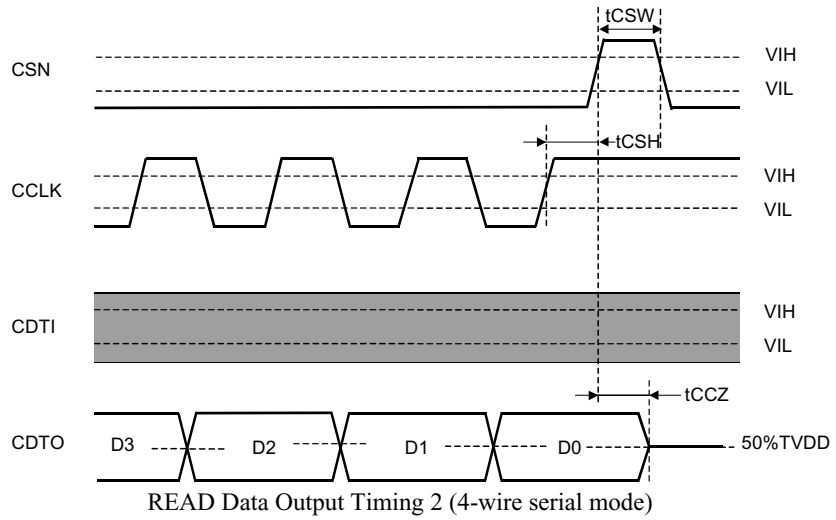

<b>OPERATION OVERVIEW</b>
---------------------------

### ■ Non-PCM (AC-3, MPEG, etc.), DTS-CD Bitstream Detect

The AK4586 has the Non-PCM stream auto detect function. When the 32bit mode Non-PCM preamble based on Dolby “AC-3 Data Stream in IEC60958 Interface” is detected, the AUTO bit goes to “1”. The 16bit mode Non-PCM preamble is not detected. The AUTO bit remains “0” at that time. The 96bit sync code consists of 0x0000, 0x0000, 0x0000, 0x0000, 0xF872 and 0x4E1F. Detection of this pattern will set the AUTO bit “1”. Once the AUTO is set to “1”, it will remain “1” until 4096 frames pass through the chip without additional sync pattern being detected. When those preambles are detected, the burst preambles Pc and Pd that follow those sync codes are stored to registers 0DH-10H. The AK4586 also has the DTS-CD stream auto detect function. When the AK4586 detects the DTS-CD bitstreams, the DTSCD bit goes to “1”. When the next sync code does not come within 4096 flames, the DTSCD bit goes to “0” until the AK4586 detects the stream again.

### ■ Clock Recovery and 96kHz Detect

On chip low jitter PLL has a wide lock range with 32kHz to 96kHz and the lock time is less than 20ms. The 96kHz detect bit RFS96 goes to “1” when the sampling rate is 88.2kHz or more and “0” at 48kHz or less. PLL loses lock when the received sync interval is incorrect.

### ■ Clock Operation Mode

The CM0 and CM1 bits select the clock source of MCKO and the data source of SDTO (Table 1). In mode 2, the clock source is switched from PLL to X'tal when PLL goes to the unlock state. In mode 3, the clock source is fixed to X'tal, but PLL is also operating and the recovered data such as C bits can be monitored.

Mode	CM1	CM0	UNLOCK	PLL	X'tal	Clock source	SDTO
0	0	0	-	ON	OFF	PLL	RX
1	0	1	-	OFF	ON	X'tal	ADC
2	1	0	0	ON	ON	PLL	RX
			1	ON	ON	X'tal	ADC
3	1	1	-	ON	ON	X'tal	ADC

Default

ON: Oscillation (Power-up), OFF: STOP (Power-down)

Table 1. Clock Operation Mode Select

### ■ System Clock

The AK4586 has the master clock output pin, MCKO. This clock is derived from either the recovered clock or from the crystal oscillator. In the PLL mode, the frequency of the master clock output (MCKO) is set by OCKS0 and OCKS1 bits as shown in Table 2. 96kHz sampling is not supported at mode 2. MCKO goes to “L” when the AK4586 detect 96kHz sampling at mode 2. Sampling speed mode is set by RFS96 or XFS96 bit (Table 3). In the x'tal mode, the x'tal frequency rate to fs is set by ICKS1-0 bits (Table 4). In the x'tal mode, the frequency of the MCKO pin becomes half of the crystal oscillator if the CLKDIV bit is set to “1” (Table 5). ICKS1-0 and XFS96 bits should be changed while RSTN bit is “0”. If the external clocks are not present, the AK4586 should be in the power-down mode (PDN= “L”) or in the reset mode (RSTN= “0”).

Mode	OCKS1	OCKS0	MCKO	fs
0	0	0	256fs	32kHz~96kHz
1	0	1	128fs	32kHz~96kHz
2	1	0	512fs	32kHz~48kHz
3	1	1	Reserved	

Default

Table 2. Master Clock Output Frequency Select (PLL mode)

Clock mode	AFS96	RFS96	XFS96	Sampling Speed (fs)	
				Normal Speed Mode	Double Speed Mode
X'tal mode	x	x	0	Normal Speed Mode	44.1kHz~48kHz
			1	Double Speed Mode	88.2kHz~96kHz
PLL mode	0	x	0	Normal Speed Mode	32kHz~48kHz
			1	Double Speed Mode	88.2kHz~96kHz
	1	0	x	Normal Speed Mode	32kHz~48kHz
			1	x	Double Speed Mode

Table 3. Sampling Speed Mode (x: Don't care)

Mode	ICKS1	ICKS0	Normal	Double	Default
0	0	0	256fs	128fs	
1	0	1	384fs	192fs	
2	1	0	512fs	256fs	
3	1	1	256fs	256fs	

Table 4. Master Clock Input Frequency Select (X'tal mode)  
 (In the x'tal mode, ADC is automatically powered down at 128fs and 192fs in the double speed mode.)

CLKDIV	MCKO	Default
0	XTI x1	
1	XTI x1/2	

Table 5. Master Clock Output Select (X'tal mode)

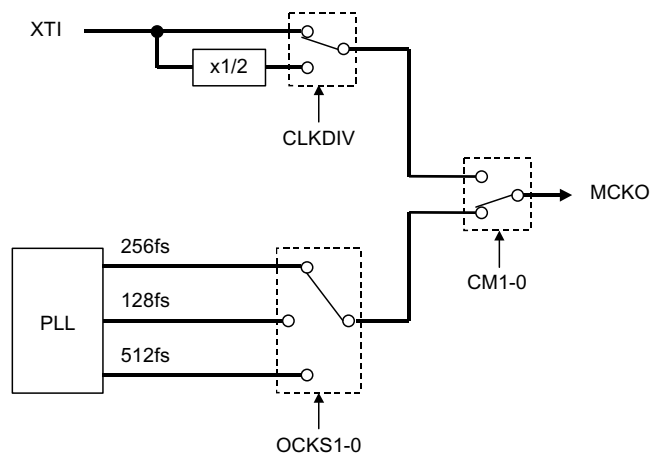

Figure 1. Master Clock Output Select

■ Clock Source

The following circuits are available to feed the clock to XTI pin of AK4586.

1) X'tal

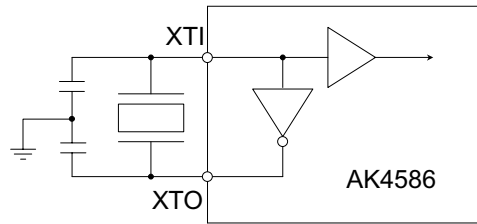

Figure 2. X'tal mode

Note: External capacitance depends on the crystal oscillator (Typ. 10-40pF)

2) External clock

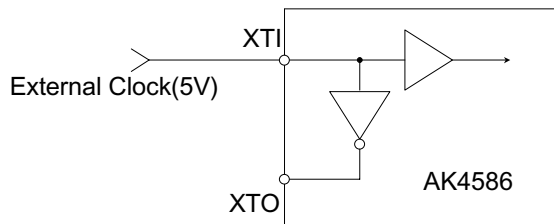

Figure 3. External clock mode(5V)

Note: Input clock must not exceed DVDD.

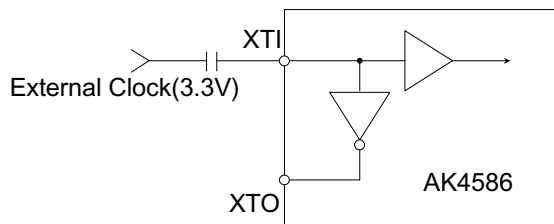

Figure 4. External clock mode(3.3V)

Note: 3.3V external clock should be AC coupled.

The amplitude of the clock should be larger than 40%DVDD.

3) Fixed to the Clock Operation Mode 0

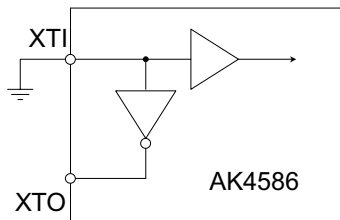

Figure 5. Off mode

### ■ Sampling Frequency and Pre-emphasis Detect

The AK4586 outputs the encoded information of sampling frequency and pre-emphasis in channel status to FS0, FS1 and PEM bits in control register. These information are output from channel 1 at default. It can be switched to channel 2 by CS12 bit in control register.

FS1	FS0	fs	Byte 3 Bits 0-3
0	0	44.1kHz	0000
0	1	Reserved	all others
1	0	48kHz	0100
1	1	32kHz	1100

Table 6. Sampling frequency information in Consumer Mode

PEM	Pre-emphasis	Byte 0 Bits 3-5
0	OFF	≠ 0X100
1	ON	0X100

Table 7. Pre-emphasis information in Consumer Mode

## ■ De-emphasis Filter Control

The AK4586 includes the digital de-emphasis filter ( $t_c=50/15\mu s$ ) by IIR filter corresponding to three sampling frequencies (32kHz, 44.1kHz and 48kHz). When DEAU bit = "1", the de-emphasis filter is enabled automatically by sampling frequency and pre-emphasis information in the channel status. The AK4586 goes to this mode at default and the de-emphasis filter is controlled by the status bits in channel 1 (Table 8). DEM1-0 and DFS bits can control the de-emphasis filter when DEAU is "0" (Table 9). The internal de-emphasis filter is bypassed and the recovered data is output without any change if either pre-emphasis or de-emphasis mode is OFF. The internal de-emphasis filter is bypassed if the Non-PCM or the DTS-CD bitstream is detected at DEAU= "1". The internal de-emphasis filter is bypassed if bit 0 of the channel status byte 0 is "1".

RFS96	FS1	FS0	DEM
0	0	0	44.1kHz
0	0	1	OFF
0	1	0	48kHz
0	1	1	32kHz
1	0	0	OFF
1	0	1	OFF
1	1	0	OFF
1	1	1	OFF

Default

Table 8. De-emphasis Auto Control at DEAU="1" and PEM="1"

Sampling Speed	DEM1	DEM0	DEM
Normal Speed	0	0	44.1kHz
Normal Speed	0	1	OFF
Normal Speed	1	0	48kHz
Normal Speed	1	1	32kHz
Double Speed	0	0	OFF
Double Speed	0	1	OFF
Double Speed	1	0	OFF
Double Speed	1	1	OFF

Default

Table 9. De-emphasis Manual Control at DEAU="0" and PEM="1"

## ■ System Reset and Power-Down

The AK4586 has a power-down mode for all circuits by PDN pin or can be partially powered-down by internal register. The AK4586 should be reset once by bringing PDN pin = "L" upon power-up. ADC, DAC and PLL are powered-down at PWVRN= "0".

PDN	PWADN	PWDAN	PWVRN	RSTN	CM1-0	Function	Register initialization
L	x	x	x	x	x	All power down	Yes
x	0	x	x	x	x	ADC power down	No
x	x	0	x	x	x	DAC power down	No
x	x	x	0	x	x	VREF power down	No
x	x	x	x	0	x	Timing Reset	No
x	x	x	x	x	00	X'tal power down	No
x	x	x	x	x	01	PLL power down	No

Table 10. Reset & Power Down

■ **Biphase Input and Through Output**

Four receiver inputs (RX1-4) are available. Each input includes amplifier corresponding to unbalance mode and can accept the signal of 200mV or more. IPS1-0 selects the receiver channel (Table 11), and OPS1-0 selects the source of the bit stream driving the transmit channel (TX, Table 12). The TX output can be stopped by setting TXE bit “0”.

IPS1	IPS0	INPUT Data
0	0	RX1
0	1	RX2
1	0	RX3
1	1	RX4

Default

Table 11. Recovery data select

OPS1	OPS0	INPUT Data
0	0	RX1
0	1	RX2
1	0	RX3
1	1	RX4

Default

Table 12. Output data select

■ Biphase signal input/output circuit

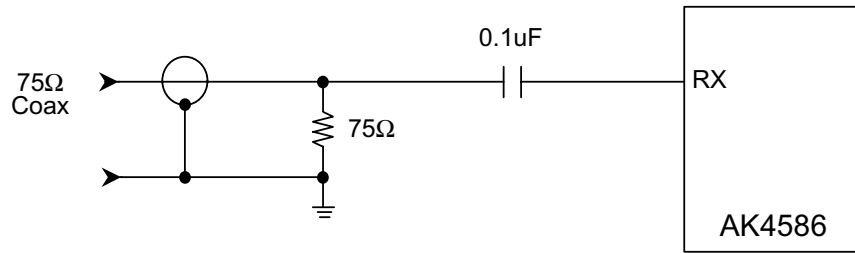

Figure 6. Consumer Input Circuit (Coaxial Input)

- Note 1: In case of coaxial input, if a coupling level to this input from the next RX input line pattern exceeds 50mV, there is a possibility to occur an incorrect operation. In this case, it is possible to lower the coupling level by adding this decoupling capacitor.
- Note 2: Ground of RCA connector and terminator should be connected to PVSS of the AK4586 with low impedance on PC board.

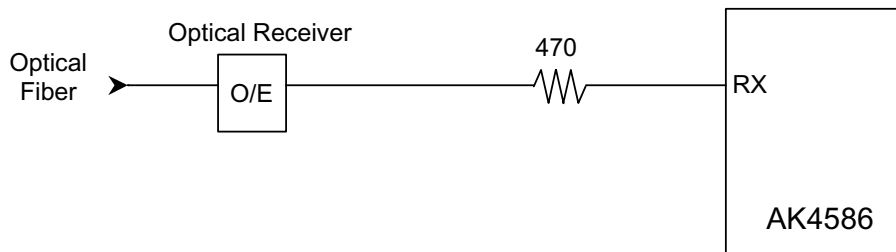

Figure 7. Consumer Input Circuit (Optical Input)

In case of coaxial input, as the input level of RX line is small, be careful not to crosstalk among RX input lines. For example, by inserting the shield pattern among them.

The AK4586 includes the TX output buffer. The output level meets combination 0.5V+/-20% using the external resistor network. The T1 in Figure 8 is a transformer of 1:1.

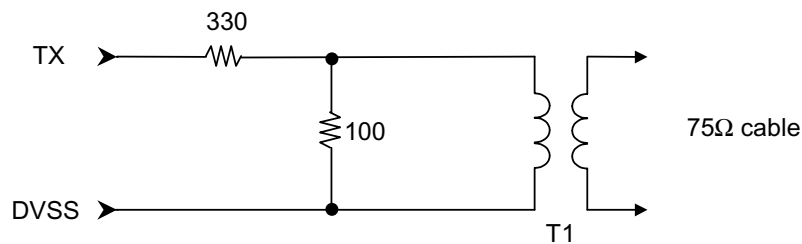

Figure 8. TX External Resistor Network

■ Error Handling

There are the following eight factors which INT1-0 pins go to “H”.

1. UNLOCK: “1” when the PLL goes UNLOCK state.  
The AK4586 loses lock when the distance between two preambles is not correct or when those preambles are not correct.
2. PAR: “1” when parity error or biphas coding error is detected.  
Updated every sub-frame cycle. Reading this register resets itself.
3. AUTO: “1” when Non-PCM Bit Stream is detected.
4. DTSCD: “1” when DTS-CD Bit Stream is detected.
5. AUDION: “1” when the “AUDIO” bit in recovered channel status indicates “1”.
6. STC: “1” when FS1, FS0 or PEM bit changes. Reading this register resets itself.
7. V: “1” when validity flag is detected.
8. RFS96: “1” when fs=88.2kHz or more (RFS96 bit is set by XFS96 bit at x’tal mode or AFS96= “0”).

INT1-0 pins output the ORed signal among those eight factors. However, each factor can be masked by each mask bit. When each bit masks those factors, the factor does not affect INT1-0 pins operation (those masks do not affect those registers (UNLOCK, PAR, etc.) themselves). Once INT0 pin goes to “H”, it maintains “H” for 1024 cycles (this value can be changed by EFH1-0 bits) after the all factors are removed. Once the PAR bit goes to “1”, it holds “1” until reading the register. While the AK4586 loses lock, the channel status bits are not updated and hold the previous data. At initial state, INT0 outputs the ORed signal between UNLOCK and PAR. INT1 outputs the ORed signal among AUTO, DTSCD, AUDION and V. INT1-0 pins are “L” when the PLL is OFF (Clock Operation Mode 1).

Register								Pin	
UNLOCK	PAR	AUTO	DTSCD	AUDION	STC	V	RFS96	SDTO	TX
1	x	x	x	x	x	x	x	“L”	Output
0	1	x	x	x	x	x	x	Previous Data	Output
0	0	1	x	x	x	x	x	Output	Output
0	0	x	1	x	x	x	x	Output	Output
0	0	x	x	1	x	x	x	Output	Output
0	0	x	x	x	1	x	x	Output	Output
0	0	x	x	x	x	1	x	Output	Output
0	0	x	x	x	x	x	1	Output	Output

Table 13. Error handling

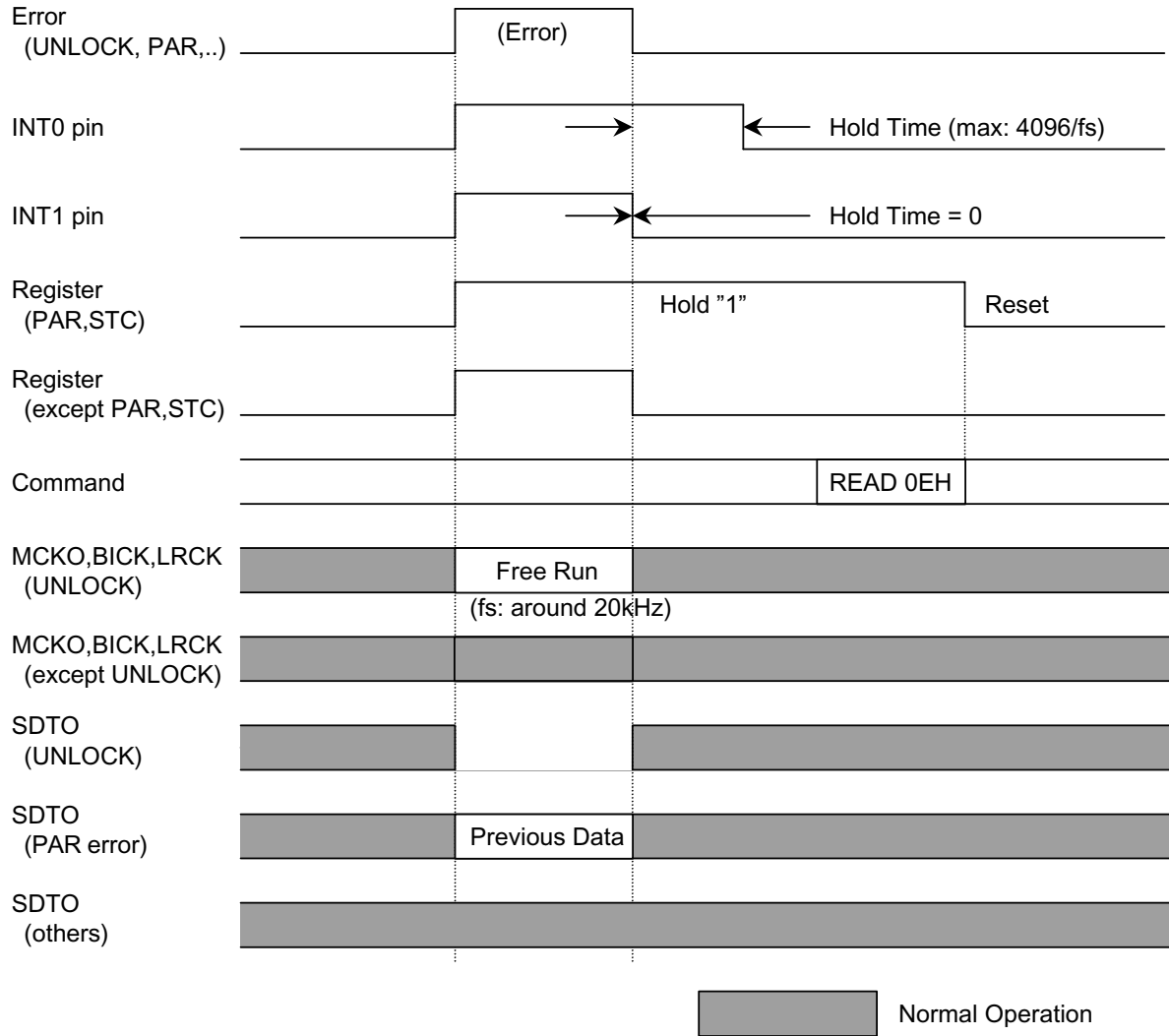

Figure 9. INT0/1 pin timing

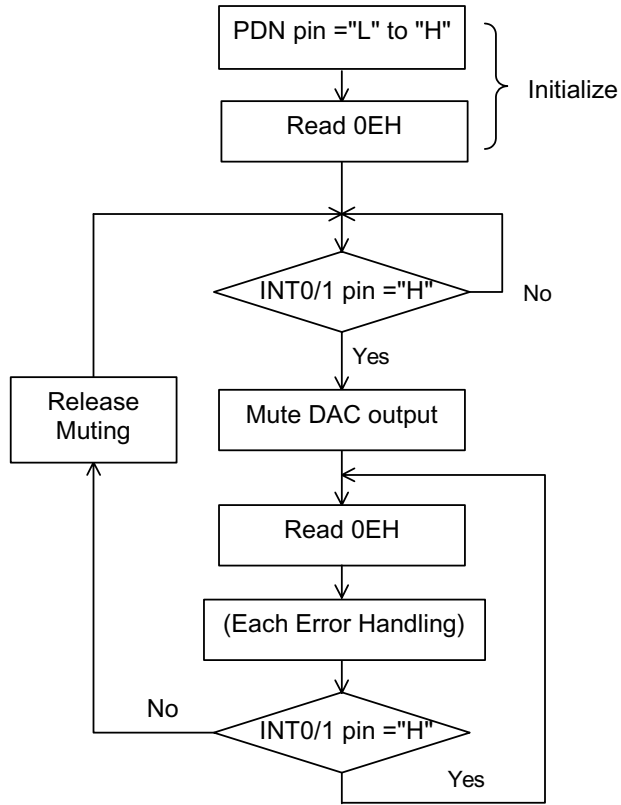

Figure 10. Error Handling Sequence Example

■ Audio Serial Interface Format

Eight serial data formats can be selected by the DIF2-0 bits as shown in Table 14 at the SLAVE pin “L”. If the SLAVE pin is “H”, the AK4586 is fixed in the slave mode and two serial data format can be selected by the DIF0 bit. In all formats the serial data is MSB-first, 2’s compliment format. The SDTO is clocked out on the falling edge of BICK and the SDTI1-3 are latched on the rising edge of BICK. BICK outputs 64fs clock in Mode 0-5. Mode 6-7 are the slave mode, and BICK is available up to 128fs at fs=48kHz. In the format equal or less than 20bit (mode 0-2), LSBs in sub-frame are truncated. In mode 3-7, the last 4LSBs are auxiliary data (see Figure 11).

When the Parity Error or Biphase Error occurs in a sub-frame, the AK4586 continues to output the last normal sub-frame data from SDTO repeatedly until the error is removed. When the Unlock Error occurs, the AK4586 outputs “0” from SDTO.

Mode 4, 5, 6 and 7 in SDTI input formats can be used for 16-20bit data by zeroing the unused LSBs.

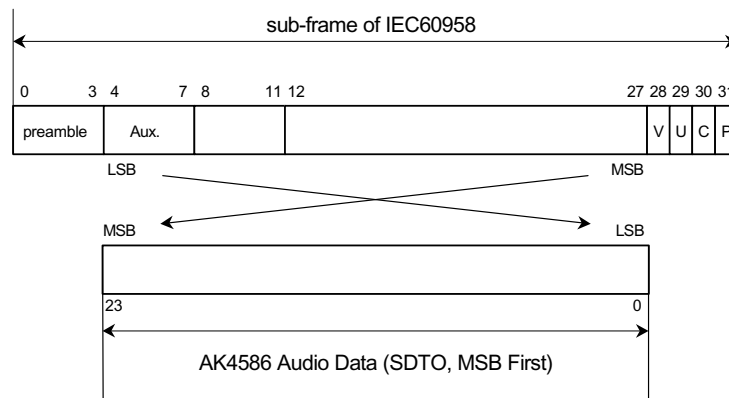

Figure 11. Bit configuration

Mode	SLAVE	DIF			SDTO	SDTI1-3	LRCK		BICK	
		2	1	0			I/O	I/O		
0	0	0	0	0	16bit, Right justified	16bit, Right justified	H/L	O	64fs	O
1		0	0	1	18bit, Right justified	18bit, Right justified	H/L	O	64fs	O
2		0	1	0	20bit, Right justified	20bit, Right justified	H/L	O	64fs	O
3		0	1	1	24bit, Right justified	24bit, Right justified	H/L	O	64fs	O
4		1	0	0	24bit, Left justified	24bit, Left justified	H/L	O	64fs	O
5		1	0	1	24bit, I <sup>2</sup> S	24bit, I <sup>2</sup> S	L/H	O	64fs	O
6		1	1	0	24bit, Left justified	24bit, Left justified	H/L	I	64-128fs	I
7	1	1	1	24bit, I <sup>2</sup> S	24bit, I <sup>2</sup> S	L/H	I	64-128fs	I	
6	1	x	x	0	24bit, Left justified	24bit, Left justified	H/L	I	64-128fs	I
7		x	x	1	24bit, I <sup>2</sup> S	24bit, I <sup>2</sup> S	L/H	I	64-128fs	I

Default

Table 14. Audio Data Format (TDM= “0”)

The audio serial interface format becomes the TDM I/F format if TDM bit is set to “1”. In the TDM mode, the serial data of all DAC (six channels) is input to the SDTI1 pin. The input data to SDTI2-3 pins is ignored. BICK should be fixed to 256fs. In the slave mode, “H” time and “L” time of LRCK should be 1/256fs at least. In the master mode, “H” time (“L” time at I<sup>2</sup>S mode) of LRCK is 1/8fs typically. LOOP1-0 should be set to “00” at the TDM mode. TDM mode cannot be used in double speed mode.

Mode	SLAVE	DIF			SDTO	SDTI1-3	LRCK		BICK	
		2	1	0			I/O	I/O		
8	0	0	0	0	16bit, Right justified	16bit, Right justified	↑	O	256fs	O
9		0	0	1	18bit, Right justified	18bit, Right justified	↑	O	256fs	O
10		0	1	0	20bit, Right justified	20bit, Right justified	↑	O	256fs	O
11		0	1	1	24bit, Right justified	24bit, Right justified	↑	O	256fs	O
12		1	0	0	24bit, Left justified	24bit, Left justified	↑	O	256fs	O
13		1	0	1	24bit, I <sup>2</sup> S	24bit, I <sup>2</sup> S	↓	O	256fs	O
14		1	1	0	24bit, Left justified	24bit, Left justified	↑	I	256fs	I
15		1	1	1	24bit, I <sup>2</sup> S	24bit, I <sup>2</sup> S	↓	I	256fs	I
14	1	x	x	0	24bit, Left justified	24bit, Left justified	↑	I	256fs	I
15		x	x	1	24bit, I <sup>2</sup> S	24bit, I <sup>2</sup> S	↓	I	256fs	I

Table 15. Audio Data Format (TDM= “1”)

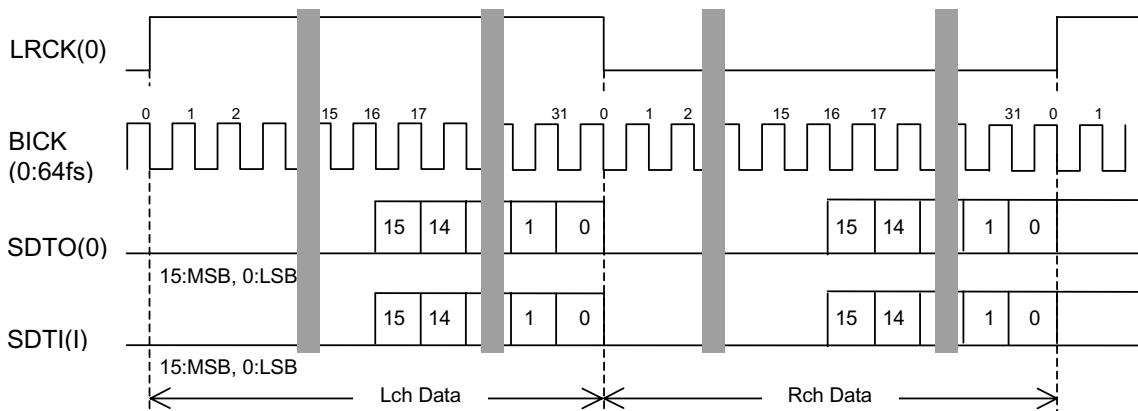

Figure 12. Mode 0 Timing

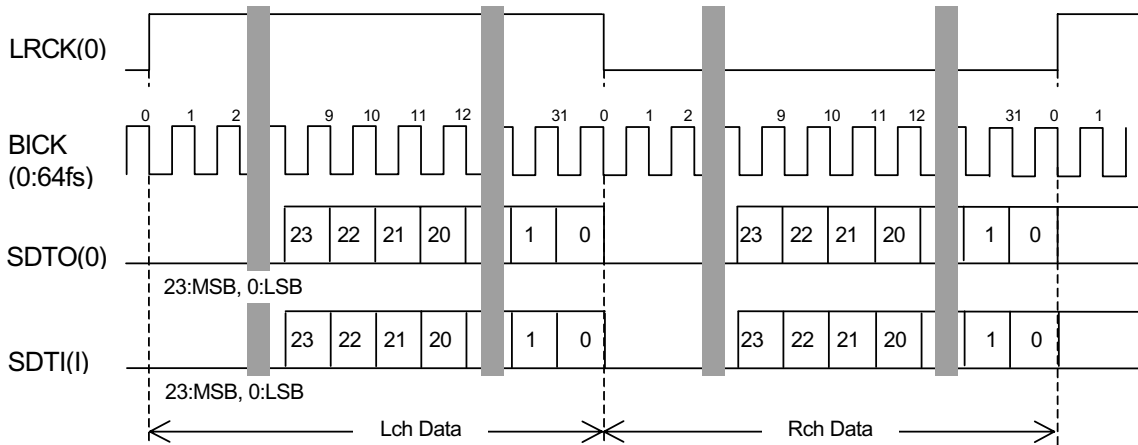

Figure 13. Mode 3 Timing

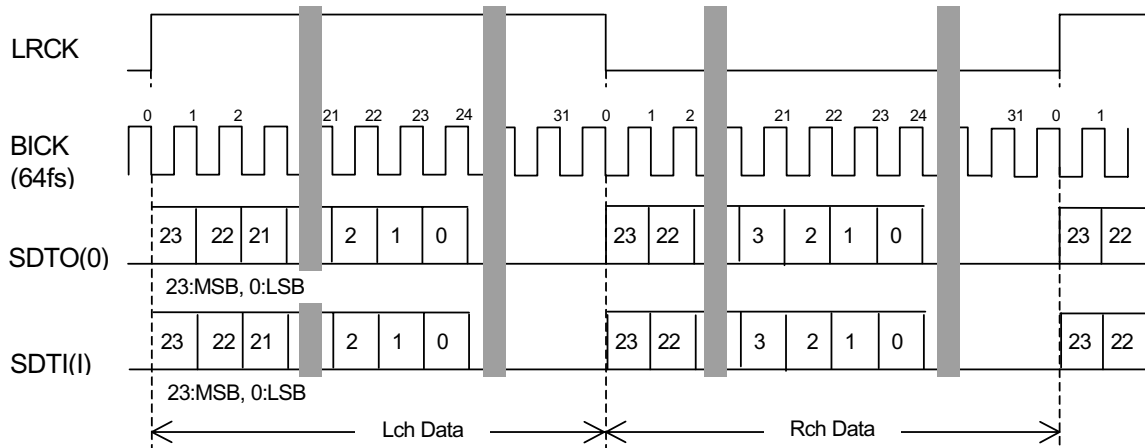

Figure 14. Mode 4, 6 Timing  
 Mode 4: LRCK, BICK: Output  
 Mode 6: LRCK, BICK: Input

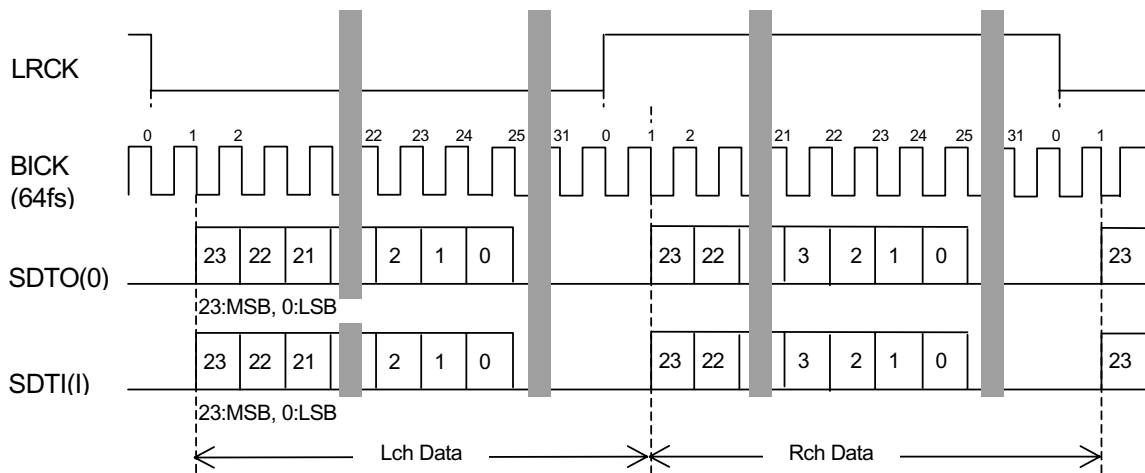

Figure 15. Mode 5, 7 Timing  
 Mode 5: LRCK, BICK: Output  
 Mode 7: LRCK, BICK: Input

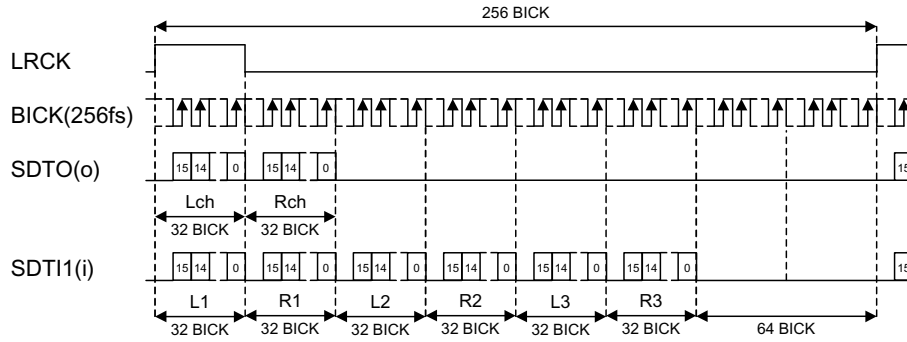

Figure 16. Mode 8 Timing

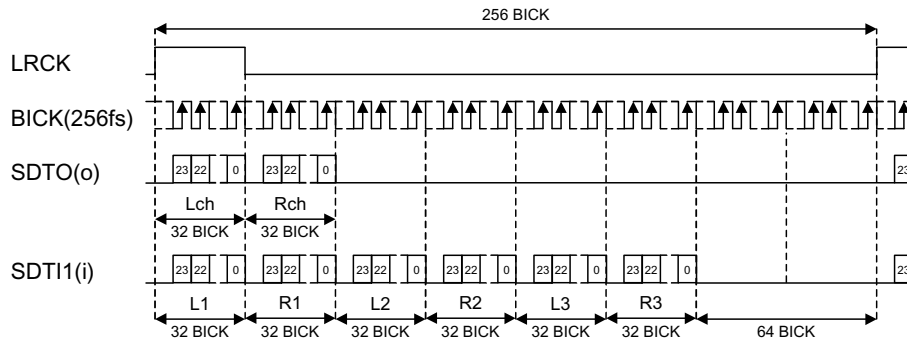

Figure 17. Mode 11 Timing

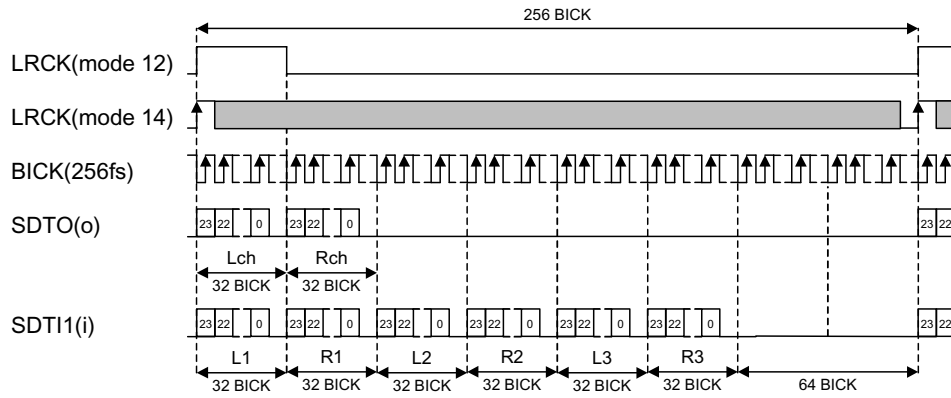

Figure 18. Mode 12, 14 Timing  
 Mode 12: LRCK, BICK: Output  
 Mode 14: LRCK, BICK: Input

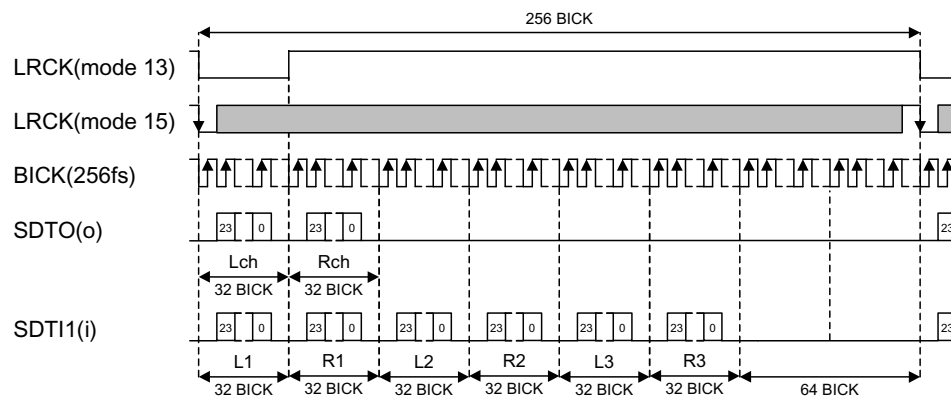

Figure 19. Mode 13, 15 Timing  
 Mode 13: LRCK, BICK: Output  
 Mode 15: LRCK, BICK: Input

### ■ Digital High Pass Filter

The ADC has a digital high pass filter for DC offset cancel. The cut-off frequency of the HPF is 1.0Hz at  $f_s=48\text{kHz}$  and also scales with sampling rate ( $f_s$ ).

### ■ Overflow Detection

The AK4586 has overflow detect function for analog input. Overflow detect function is enable if OVFE bit is set to “1”. OVF pin goes to “H” if analog input of Lch or Rch overflows (more than -0.3dBFS). OVF output for overflowed analog input has the same group delay as ADC ( $GD = 17.0/f_s = 354\mu\text{s}@f_s=48\text{kHz}$ ). OVF is “L” for  $522/f_s (=10.9\text{ms}@f_s=48\text{kHz})$  after PDN = “↑”, and then overflow detection is enabled.

### ■ Zero detection

The AK4586 has two pins for zero detect flag outputs. Channel grouping can be selected by DZFM2-0 bits (Table 16). DZF1 pin corresponds to the group 1 channels and DZF2 pin corresponds to the group 2 channels. However DZF2 pin becomes OVF pin if OVFE bit is set to “1”. For example, DZF1 is AND of all six channels and DZF2 is disabled (“L”) at mode 0.

When the input data of all channels in the group 1(group 2) are continuously zeros for 8192 LRCK cycles, DZF1(DZF2) pin goes to “H”. DZF1(DZF2) pin immediately goes to “L” if input data of any channels in the group 1(group 2) is not zero after going DZF1(DZF2) “H”.

Mode	DZFM			AOUT						
	2	1	0	L1	R1	L2	R2	L3	R3	
0	0	0	0	DZF1	DZF1	DZF1	DZF1	DZF1	DZF1	
1	0	0	1	DZF1	DZF1	DZF1	DZF1	DZF1	DZF2	
2	0	1	0	DZF1	DZF1	DZF1	DZF1	DZF2	DZF2	
3	0	1	1	DZF1	DZF1	DZF1	DZF2	DZF2	DZF2	
4	1	0	0	DZF1	DZF1	DZF2	DZF2	DZF2	DZF2	
5	1	0	1	DZF1	DZF2	DZF2	DZF2	DZF2	DZF2	
6	1	1	0	DZF2	DZF2	DZF2	DZF2	DZF2	DZF2	
7	1	1	1	disable (DZF1=DZF2 = “L”)						Default

Table 16. Zero detect control

## ■ Digital Attenuator

The AK4586 has channel-independent digital attenuator (256 levels, 0.5dB step). Attenuation level of each channel can be set by each ATT7-0 bits (Table 17).

ATT7-0	Attenuation Level
00H	0dB
01H	-0.5dB
02H	-1.0dB
:	:
FDH	-126.5dB
FEH	-127.0dB
FFH	MUTE ( $-\infty$ )

Default

Table 17. Attenuation level of digital attenuator

Transition time between set values of ATT7-0 bits can be selected by ATS1-0 bits (Table 18).

Mode	ATS1	ATS0	ATT speed
0	0	0	7424/fs
1	0	1	1061/fs
2	1	0	256/fs
3	1	1	Reserved

Default

Table 18. Transition time between set values of ATT7-0 bits

The transition between set values is soft transition of 7425 levels in mode 0. It takes 7424/fs (155ms@fs=48kHz) from 00H(0dB) to FFH(MUTE) in mode 0. If PDN pin goes to “L”, the ATTs are initialized to 00H. The ATTs are 00H when RSTN = “0”. When RSTN return to “1”, the ATTs fade to their current value. Digital attenuator is independent of soft mute function.

### ■ Soft mute operation

Soft mute operation is performed at digital domain. When the SMUTE bit goes to “1”, the output signal is attenuated by  $-\infty$  during 1024 LRCK cycles. When the SMUTE bit is returned to “0”, the mute is cancelled and the output attenuation gradually changes to 0dB during 1024 LRCK cycles. If the soft mute is cancelled within 1024 LRCK cycles after starting the operation, the attenuation is discontinued and returned to 0dB. The soft mute is effective for changing the signal source without stopping the signal transmission.

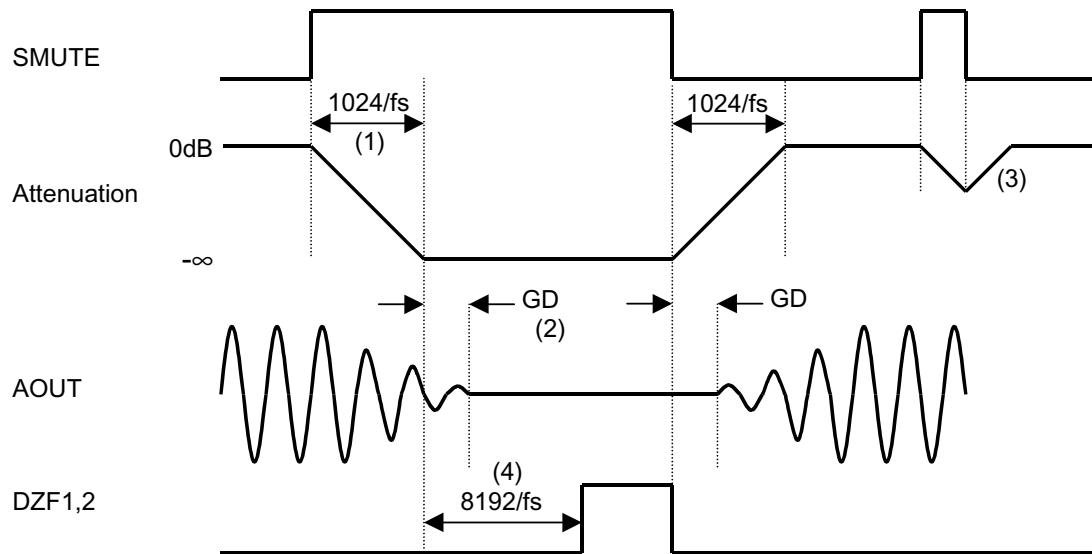

Notes:

- (1) The output signal is attenuated by  $-\infty$  during 1024 LRCK cycles ( $1024/f_s$ ).
- (2) Analog output corresponding to digital input have the group delay (GD).
- (3) If the soft mute is cancelled within 1024 LRCK cycles, the attenuation is discontinued and returned to 0dB.
- (4) When the input data of all channels in the group are continuously zeros for 8192 LRCK cycles, DZF pin corresponding to the group goes to “H”. DZF pin immediately goes to “L” if input data of any channel in the group is not zero after going DZF “H”.

Figure 20. Soft mute and zero detection

■ Serial Control Interface

(1) 4-wire Serial Control Mode (I2C = "L")

The internal registers may be either written or read by the 4-wire  $\mu$ P interface pins: CSN, CCLK, CDTI & CDTO. The data on this interface consists of Chip address (2bits, CAD1-0 are fixed to "00"), Read/Write (1bit), Register address (MSB first, 5bits) and Control data (MSB first, 8bits). Address and data is clocked in on the rising edge of CCLK and data is clocked out on the falling edge. For write operations, data is latched after the 16th rising edge of CCLK, after a high-to-low transition of CSN. For read operations, the CDTO output goes high impedance after a low-to-high transition of CSN. The maximum speed of CCLK is 5MHz. PDN= "L" resets the registers to their default values.

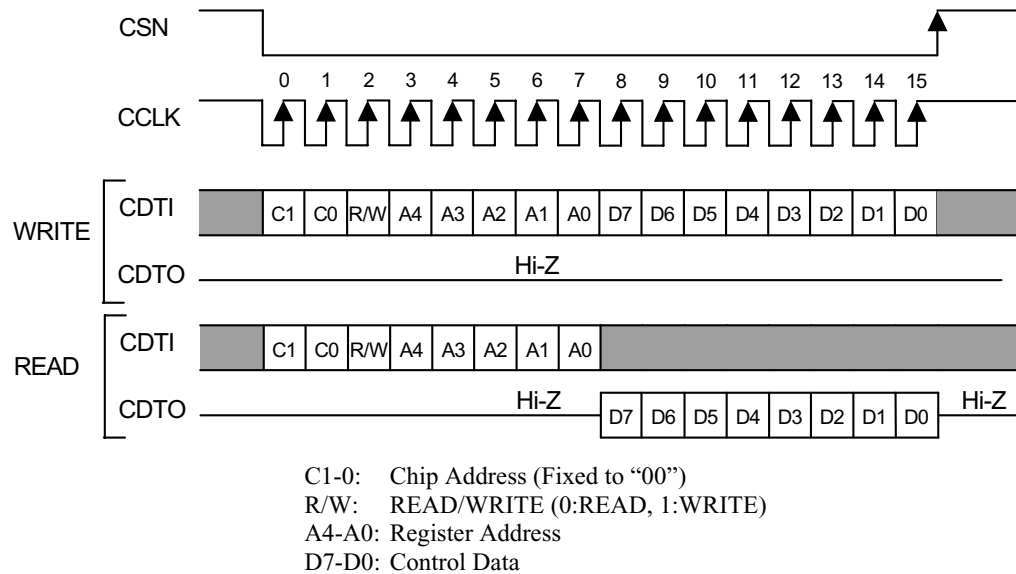

Figure 21. 4-wire Serial Control I/F Timing

(2) I<sup>2</sup>C-bus Control Mode (I2C= "H")

AK4586 supports the standard-mode I<sup>2</sup>C-bus (max:100kHz). Then AK4586 cannot be incorporated in a fast-mode I<sup>2</sup>C-bus system (max:400kHz).

(2)-1. WRITE Operations

Figure 22 shows the data transfer sequence at the I<sup>2</sup>C-bus mode. All commands are preceded by a START condition. A HIGH to LOW transition on the SDA line while SCL is HIGH indicates a START condition (Figure 28). After the START condition, a slave address is sent. This address is 7 bits long followed by an eighth bit which is a data direction bit (R/W). The most significant five bits of the slave address are fixed as "00100". The next two bits are CAD1 and CAD0 (device address bits). These two bits identify the specific device on the bus. The hard-wired input pins (CAD1 pin and CAD0 pin) set them (Figure 23). If the slave address match that of the AK4586, the AK4586 generates the acknowledge and the operation is executed. The master must generate the acknowledge-related clock pulse and release the SDA line (HIGH) during the acknowledge clock pulse (Figure 29). A "1" for R/W bit indicates that the read operation is to be executed. A "0" indicates that the write operation is to be executed.

The second byte consists of the address for control registers of the AK4586. The format is MSB first, and those most significant 3-bits are fixed to zeros (Figure 24). Those data after the second byte contain control data. The format is MSB first, 8bits (Figure 25). The AK4586 generates an acknowledge after each byte has been received. A data transfer is always terminated by a STOP condition generated by the master. A LOW to HIGH transition on the SDA line while SCL is HIGH defines a STOP condition (Figure 28).

The AK4586 is capable of more than one byte write operation by one sequence. After receipt of the third byte, the AK4586 generates an acknowledge, and awaits the next data again. The master can transmit more than one byte instead of terminating the write cycle after the first data byte is transferred. After the receipt of each data, the internal 5bits address counter is incremented by one, and the next data is taken into next address automatically. If the address exceed 1FH prior to generating the stop condition, the address counter will "roll over" to 00H and the previous data will be overwritten. The data on the SDA line must be stable during the HIGH period of the clock. The HIGH or LOW state of the data line can only change when the clock signal on the SCL line is LOW (Figure 30) except for the START and the STOP condition.

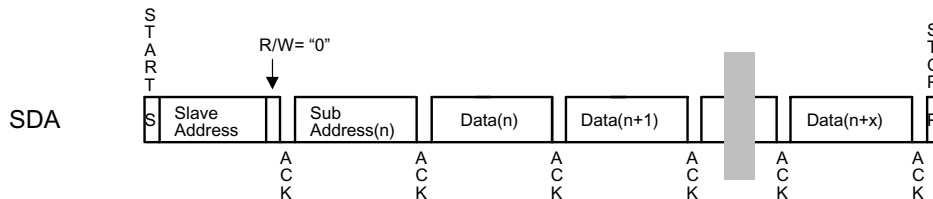

Figure 22. Data transfer sequence at the I<sup>2</sup>C-bus mode

0	0	1	0	0	CAD1	CAD0	R/W
---	---	---	---	---	------	------	-----

(Those CAD1/0 should match with CAD1/0 pins)

Figure 23. The first byte

0	0	0	A4	A3	A2	A1	A0
---	---	---	----	----	----	----	----

Figure 24. The second byte

D7	D6	D5	D4	D3	D2	D1	D0
----	----	----	----	----	----	----	----

Figure 25. Byte structure after the second byte

(2)-2. READ Operations

Set R/W bit = "1" for the READ operation of the AK4586. After transmission of a data, the master can read next address's data by generating the acknowledge instead of terminating the write cycle after the receipt the first data word. After the receipt of each data, the internal 5bits address counter is incremented by one, and the next data is taken into next address automatically. If the address exceed 1FH prior to generating the stop condition, the address counter will "roll over" to 00H and the previous data will be overwritten.

The AK4586 supports two basic read operations: CURRENT ADDRESS READ and RANDOM READ.

(2)-2-1. CURRENT ADDRESS READ

The AK4586 contains an internal address counter that maintains the address of the last word accessed, incremented by one. Therefore, if the last access (either a read or write) was to address n, the next CURRENT READ operation would access data from the address n+1. After receipt of the slave address with R/W bit set to "1", the AK4586 generates an acknowledge, transmits 1byte data which address is set by the internal address counter and increments the internal address counter by 1. If the master does not generate an acknowledge to the data but generate the stop condition, the AK4586 discontinues transmission

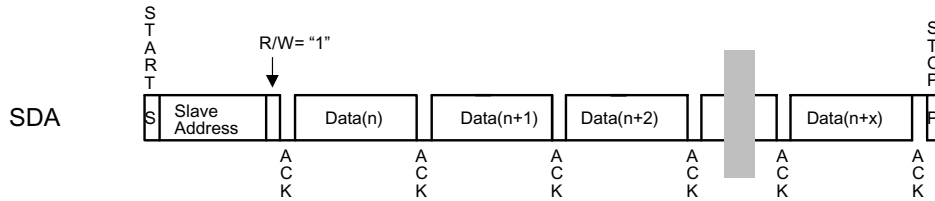

Figure 26. CURRENT ADDRESS READ

(2)-3-2. RANDOM READ

Random read operation allows the master to access any memory location at random. Prior to issuing the slave address with the R/W bit set to "1", the master must first perform a "dummy" write operation. The master issues the start condition, slave address(R/W="0") and then the register address to read. After the register address's acknowledge, the master immediately reissues the start condition and the slave address with the R/W bit set to "1". Then the AK4586 generates an acknowledge, 1byte data and increments the internal address counter by 1. If the master does not generate an acknowledge to the data but generate the stop condition, the AK4586 discontinues transmission.

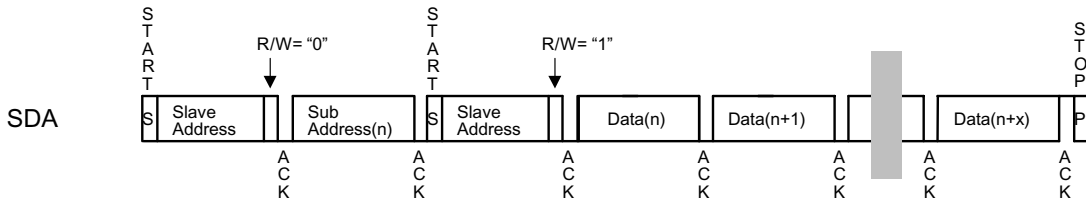

Figure 27. RANDOM ADDRESS READ

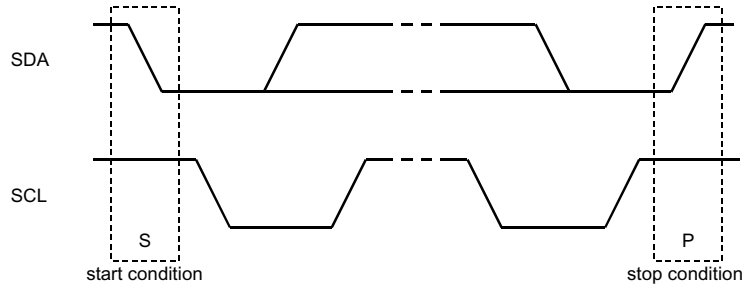

Figure 28. START and STOP conditions

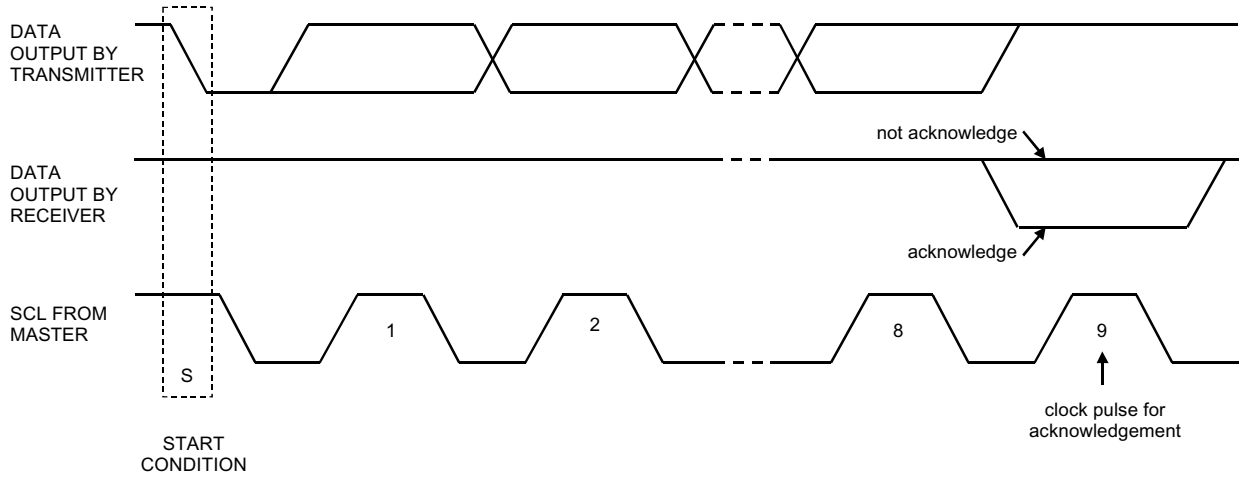

Figure 29. Acknowledge on the I<sup>2</sup>C-bus

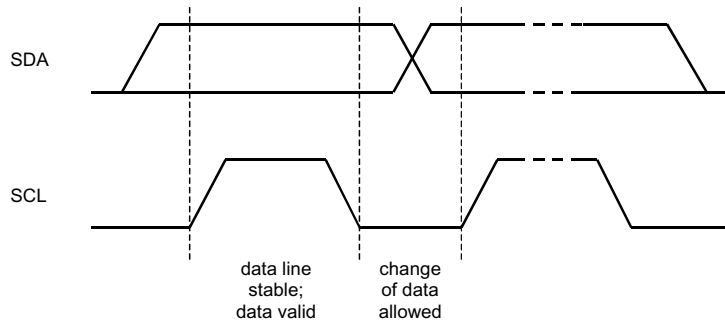

Figure 30. Bit transfer on the I<sup>2</sup>C-bus

### ■ Mapping of Program Registers

Addr	Register Name	D7	D6	D5	D4	D3	D2	D1	D0
00H	Power Down & Reset	0	0	0	0	PWVRN	PWADN	PWDAN	RSTN
01H	Path Control	0	0	LOOP1	LOOP0	IPS1	IPS0	OPS1	OPS0
02H	Clock Mode Control	0	CLKDIV	OCKS1	OCKS0	ICKS1	ICKS0	CM1	CM0
03H	Output Control	0	SMUTE	TXE	BCU	OVFE	DZFM2	DZFM1	DZFM0
04H	Receiver Control	XFS96	AFS96	CS12	EFH1	EFH0	DEAU	DEM1	DEM0
05H	I/F Format & ATT Speed	0	0	ATS1	ATS0	TDM	DIF2	DIF1	DIF0
06H	LOUT1 Volume Control	ATT7	ATT6	ATT5	ATT4	ATT3	ATT2	ATT1	ATT0
07H	ROUT1 Volume Control	ATT7	ATT6	ATT5	ATT4	ATT3	ATT2	ATT1	ATT0
08H	LOUT2 Volume Control	ATT7	ATT6	ATT5	ATT4	ATT3	ATT2	ATT1	ATT0
09H	ROUT2 Volume Control	ATT7	ATT6	ATT5	ATT4	ATT3	ATT2	ATT1	ATT0
0AH	LOUT3 Volume Control	ATT7	ATT6	ATT5	ATT4	ATT3	ATT2	ATT1	ATT0
0BH	ROUT3 Volume Control	ATT7	ATT6	ATT5	ATT4	ATT3	ATT2	ATT1	ATT0
0CH	INT0 Mask	MRFS0	MV0	MSTC0	MAUD0	MDTS0	MAUT0	MPAR0	MUNL0
0DH	INT1 Mask	MRFS1	MV1	MSTC1	MAUD1	MDTS1	MAUT1	MPAR1	MUNL1
0EH	Receiver Status 0	RFS96	V	STC	AUDION	DTSCD	AUTO	PAR	UNLOCK
0FH	Receiver Status 1	0	0	0	0	0	PEM	FS1	FS0
10H	Channel Status Byte 0	C7	C6	C5	C4	C3	C2	C1	C0
11H	Channel Status Byte 1	C15	C14	C13	C12	C11	C10	C9	C8
12H	Channel Status Byte 2	C23	C22	C21	C20	C19	C18	C17	C16
13H	Channel Status Byte 3	C31	C30	C29	C28	C27	C26	C25	C24
14H	Burst Preamble Pc Byte 0	PC7	DTSCD	PC5	PC4	PC3	PC2	PC1	PC0
15H	Burst Preamble Pc Byte 1	PC15	PC14	PC13	PC12	PC11	PC10	PC9	PC8
16H	Burst Preamble Pd Byte 0	PD7	PD6	PD5	PD4	PD3	PD2	PD1	PD0
17H	Burst Preamble Pd Byte 1	PD15	PD14	PD13	PD12	PD11	PD10	PD9	PD8

Note: For addresses from 18H to 1FH, data is not written.

When PDN goes to “L”, the registers are initialized to their default values.

When RSTN bit goes to “0”, the internal timing is reset and DZF1-2 pins go to “H”, but registers are not initialized to their default values.

All data can be written to the register even if PWVRN, PWADN or PWDAN bit is “0”.

## ■ Register Definitions

Addr	Register Name	D7	D6	D5	D4	D3	D2	D1	D0
00H	Power Down & Reset	0	0	0	0	PWVRN	PWADN	PWDAN	RSTN
	R/W	RD	RD	RD	RD	R/W	R/W	R/W	R/W
	Default	0	0	0	0	1	1	1	1

RSTN: Internal timing reset

0: Reset. DZF1-2 pins go to “H”, but registers are not initialized.

1: Normal operation

PWDAN: Power-down control of DAC1-3

0: Power-down

1: Normal operation

PWADN: Power-down control of ADC

0: Power-down

1: Normal operation

PWVRN: Power-down control of reference voltage

0: Power-down. ADC, DAC and PLL are powered-down.

1: Normal operation

Addr	Register Name	D7	D6	D5	D4	D3	D2	D1	D0
01H	Path Control	0	0	LOOP1	LOOP0	IPS1	IPS0	OPS1	OPS0
	R/W	RD	RD	R/W	R/W	R/W	R/W	R/W	R/W
	Default	0	0	0	0	0	0	0	0

OPS1-0: Output Through Data Select (Table 12)

Default: “00”, RX1

IPS1-0: Input Recovery Data Select (Table 11)

Default: “00”, RX1

LOOP1-0: Loopback mode enable

00: Normal (No loop back)

01: LIN → LOUT1, LOUT2, LOUT3, LOUT4

RIN → ROUT1, ROUT2, ROUT3, ROUT4

The ADC digital output (RX data in the PLL mode) is connected to the digital DAC input. In this mode, the input DAC data to SDTI1-3 is ignored.

10: SDTI1(L) → SDTI2(L), SDTI3(L)

SDTI1(R) → SDTI2(R), SDTI3(R)

In this mode the input DAC data to SDTI2-3 is ignored.

11: N/A

LOOP1-0 should be set to “00” at TDM bit “1”.

Addr	Register Name	D7	D6	D5	D4	D3	D2	D1	D0
02H	Clock Mode Control	0	CLKDIV	OCKS1	OCKS0	ICKS1	ICKS0	CM1	CM0
	R/W	RD	R/W	R/W	R/W	R/W	R/W	R/W	R/W
	Default	0	0	0	0	0	0	0	0

CM1-0: Master Clock Operation Mode Select (Table 1)

Default: "00", mode 0

OCKS1-0: Master Clock Output Frequency Select at PLL mode (Table 2)

Default: "00", mode 0

ICKS1-0: Master Clock Input Frequency Select at X'tal mode (Table 4)

Default: "00", mode 0

CLKDIV: Master Clock Output Select at X'tal mode (Table 5)

0: Same frequency as crystal oscillator

1: Half frequency of crystal oscillator

Addr	Register Name	D7	D6	D5	D4	D3	D2	D1	D0
03H	Output Control	0	SMUTE	TXE	BCU	OVFE	DZFM2	DZFM1	DZFM0
	R/W	RD	R/W	R/W	R/W	R/W	R/W	R/W	R/W
	Default	0	0	1	0	0	1	1	1

DZFM2-0: Zero detect mode select (Table 16)

Initial: "111", disable

OVFE: Overflow detection enable

0: Disable, pin#20 becomes DZF2 pin.

1: Enable, pin#20 becomes OVF pin.

BCU: Block Start and C/U/V Output Mode

When BCU=1, the 4 output pins change another function.

DZF1 Pin → Block start signal

DZF2 Pin → C bit

INT1 Pin → U bit

TX Pin → V bit

The block signal goes high at the start of frame 0 and remains high until the end of frame 31.

(B, C, U, V output timing at RX mode, master mode)

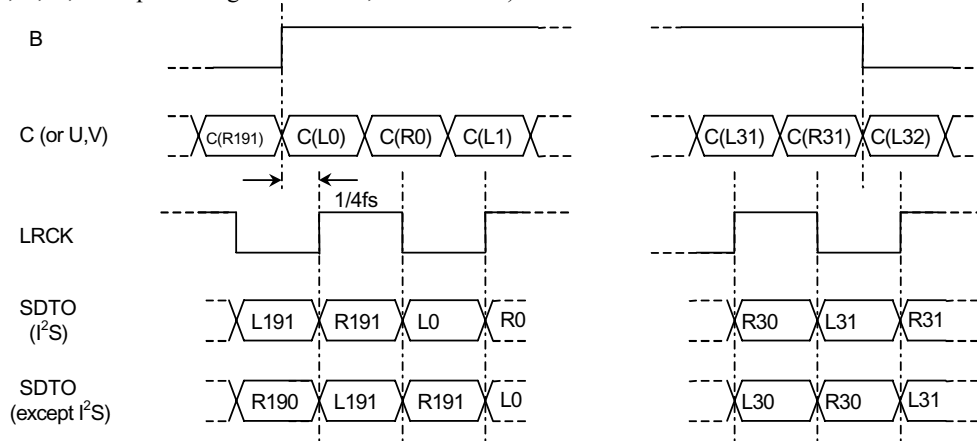

TXE: TX Output Enable

0: Disable. TX output is "L".

1: Enable

SMUTE: Soft Mute Enable (Figure 20)

0: Normal operation

1: All DAC outputs soft-muted

Addr	Register Name	D7	D6	D5	D4	D3	D2	D1	D0
04H	Receiver Control	XFS96	AFS96	CS12	EFH1	EFH0	DEAU	DEM1	DEM0
	R/W	R/W	R/W	R/W	R/W	R/W	R/W	R/W	R/W
	Default	0	1	0	0	1	1	0	1

DEM1-0: De-emphasis Control (Table 9)

The setting of DEM1-0 bits is ignored at DEAU bit “1”.

Default: “01”, OFF

DEAU: De-emphasis Auto Detect Enable

0: Disable

1: Enable

EFH1-0: Interrupt 0 Pin Hold Count Select

00: 512 LRCK

01: 1024 LRCK (default)

10: 2048 LRCK

11: 4096 LRCK

CS12: Channel Status Select

0: Channel 1

1: Channel 2

Selects which channel status is used to derive C-bit buffers, AUDION, PEM, FS1 and FS0.

AFS96: Sampling Speed Mode Auto Setting Mode Enable (Table 3)

0: Disable, sampling mode is set by XFS96 bit.

1: Enable, sampling mode is automatically set by the register value of RFS96 bit at PLL mode.

XFS96: ADC and DAC Sampling Speed Mode Select (X’tal Mode or AFS96= “0”, Table 3)

0: Normal speed mode

1: Double speed mode

The sampling speed mode is defined by RFS96 and the setting of XFS96 is ignored at AFS96 bit “1” in the PLL mode.

Addr	Register Name	D7	D6	D5	D4	D3	D2	D1	D0
05H	I/F Format & ATT Speed	0	0	ATS1	ATS0	TDM	DIF2	DIF1	DIF0
	R/W	RD	RD	R/W	R/W	R/W	R/W	R/W	R/W
	Default	0	0	0	0	0	1	0	0

DIF2-0: Audio Data Format Control (Table 14, Table 15)

Default: “100”, mode 4

TDM: TDM Format Select

0: Normal format

1: TDM format

ATS1-0: Digital attenuator transition time setting (Table 18)

Default: “00”, mode 0

Addr	Register Name	D7	D6	D5	D4	D3	D2	D1	D0
06H	LOUT1 Volume Control	ATT7	ATT6	ATT5	ATT4	ATT3	ATT2	ATT1	ATT0
07H	ROUT1 Volume Control	ATT7	ATT6	ATT5	ATT4	ATT3	ATT2	ATT1	ATT0
08H	LOUT2 Volume Control	ATT7	ATT6	ATT5	ATT4	ATT3	ATT2	ATT1	ATT0
09H	ROUT2 Volume Control	ATT7	ATT6	ATT5	ATT4	ATT3	ATT2	ATT1	ATT0
0AH	LOUT3 Volume Control	ATT7	ATT6	ATT5	ATT4	ATT3	ATT2	ATT1	ATT0
0BH	ROUT3 Volume Control	ATT7	ATT6	ATT5	ATT4	ATT3	ATT2	ATT1	ATT0
	R/W	R/W	R/W	R/W	R/W	R/W	R/W	R/W	R/W
	Default	0	0	0	0	0	0	0	0

ATT7-0: Attenuation Level (Table 17)  
 Default: all "0" (0dB)

Addr	Register Name	D7	D6	D5	D4	D3	D2	D1	D0
0CH	INT0 Mask	MRFS0	MV0	MSTC0	MAUD0	MDTS0	MAUT0	MPAR0	MUNL0
	R/W	R/W	R/W	R/W	R/W	R/W	R/W	R/W	R/W
	Default	1	1	1	1	1	1	0	0

MULK0: Mask Enable for UNLOCK bit (Default: 0)

0: Mask disable 1: Mask enable

MPAR0: Mask Enable for PAR bit (Default: 0)

0: Mask disable 1: Mask enable

MAUT0: Mask Enable for AUTO bit (Default: 1)

0: Mask disable 1: Mask enable

MDTS0: Mask Enable for DTSCD bit (Default: 1)

0: Mask disable 1: Mask enable

MAUD0: Mask Enable for AUDIO bit (Default: 1)

0: Mask disable 1: Mask enable

MSTC0: Mask Enable for STC bit (Default: 1)

0: Mask disable 1: Mask enable

MV0: Mask Enable for V bit (Default: 1)

0: Mask disable 1: Mask enable

MRFS0: Mask Enable for RFS96 bit (Default: 1)

0: Mask disable 1: Mask enable

Addr	Register Name	D7	D6	D5	D4	D3	D2	D1	D0
0DH	INT1 Mask	MRFS1	MV1	MSTC1	MAUD1	MDTS1	MAUT1	MPAR1	MUNL1
	R/W	R/W	R/W	R/W	R/W	R/W	R/W	R/W	R/W
	Default	1	0	1	0	0	0	1	1

MULK1: Mask Enable for UNLOCK bit (Default: 1)

0: Mask disable 1: Mask enable

MPAR1: Mask Enable for PAR bit (Default: 1)

0: Mask disable 1: Mask enable

MAUT1: Mask Enable for AUTO bit (Default: 0)

0: Mask disable 1: Mask enable

MDTS1: Mask Enable for DTSCD bit (Default: 0)

0: Mask disable 1: Mask enable

MAUD1: Mask Enable for AUDIO bit (Default: 0)

0: Mask disable 1: Mask enable

MSTC1: Mask Enable for STC bit (Default: 1)

0: Mask disable 1: Mask enable

MV1: Mask Enable for V bit (Default: 0)

0: Mask disable 1: Mask enable

MRFS1: Mask Enable for RFS96 bit (Default: 1)

0: Mask disable 1: Mask enable



Addr	Register Name	D7	D6	D5	D4	D3	D2	D1	D0
10H	Channel Status Byte 0	C7	C6	C5	C4	C3	C2	C1	C0
11H	Channel Status Byte 1	C15	C14	C13	C12	C11	C10	C9	C8
12H	Channel Status Byte 2	C23	C22	C21	C20	C19	C18	C17	C16
13H	Channel Status Byte 3	C31	C30	C29	C28	C27	C26	C25	C24
R/W		RD							
Default		Not initialized							

C31-0: Channel Status Byte 3-0

Addr	Register Name	D7	D6	D5	D4	D3	D2	D1	D0
14H	Burst Preamble Pc Byte 0	PC7	PC6	PC5	PC4	PC3	PC2	PC1	PC0
15H	Burst Preamble Pc Byte 1	PC15	PC14	PC13	PC12	PC11	PC10	PC9	PC8
16H	Burst Preamble Pd Byte 0	PD7	PD6	PD5	PD4	PD3	PD2	PD1	PD0
17H	Burst Preamble Pd Byte 1	PD15	PD14	PD13	PD12	PD11	PD10	PD9	PD8
R/W		RD							
Default		Not initialized							

PC15-0: Burst Preamble Pc Byte 0 and 1

PD15-0: Burst Preamble Pd Byte 0 and 1

■ Burst Preambles in Non-PCM Bitstreams

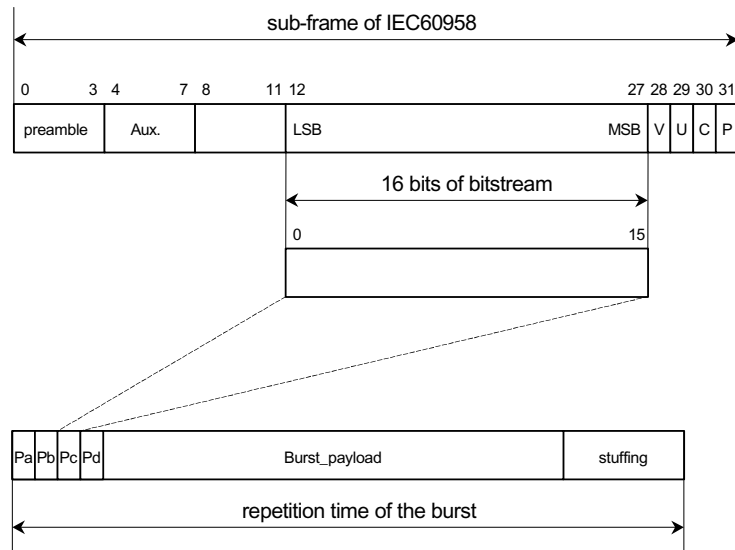

Figure 31. Data structure in IEC60958

Preamble word	Length of field	Contents	Value
Pa	16 bits	sync word 1	0xF872
Pb	16 bits	sync word 2	0x4E1F
Pc	16 bits	Burst info	see Table 20
Pd	16 bits	Length code	numbers of bits

Table 19. Burst preamble words

Bits of Pc	Value	Contents	Repetition time of burst in IEC60958 frames
0-4	0	data type NULL data	≤4096
	1	Dolby AC-3 data	1536
	2	reserved	
	3	PAUSE	
	4	MPEG-1 Layer1 data	384
	5	MPEG-1 Layer2 or 3 data or MPEG-2 without extension	1152
	6	MPEG-2 data with extension	1152
	7	reserved	
	8	MPEG-2, Layer1 Low sample rate	384
	9	MPEG-2, Layer2 or 3 Low sample rate	1152
	10	reserved	
	11	DTS type I	512
	12	DTS type II	1024
	13	DTS type III	2048
	14	ATRAC	512
	15	ATRAC2/3	1024
	16-26	reserved	
27	(reserved for MPEG-4 AAC data)	512	
28	MPEG-2 AAC data	1024	
29-31	reserved		
5, 6	0	reserved, shall be set to "0"	
7	0	error-flag indicating a valid burst_payload	
	1	error-flag indicating that the burst_payload may contain errors	
8-12		data type dependent info	
13-15	0	bit stream number, shall be set to "0"	

Table 20. Fields of burst info Pc

■ Non-PCM Bitstream timing

1) When Non-PCM preamble is not coming within 4096 frames,

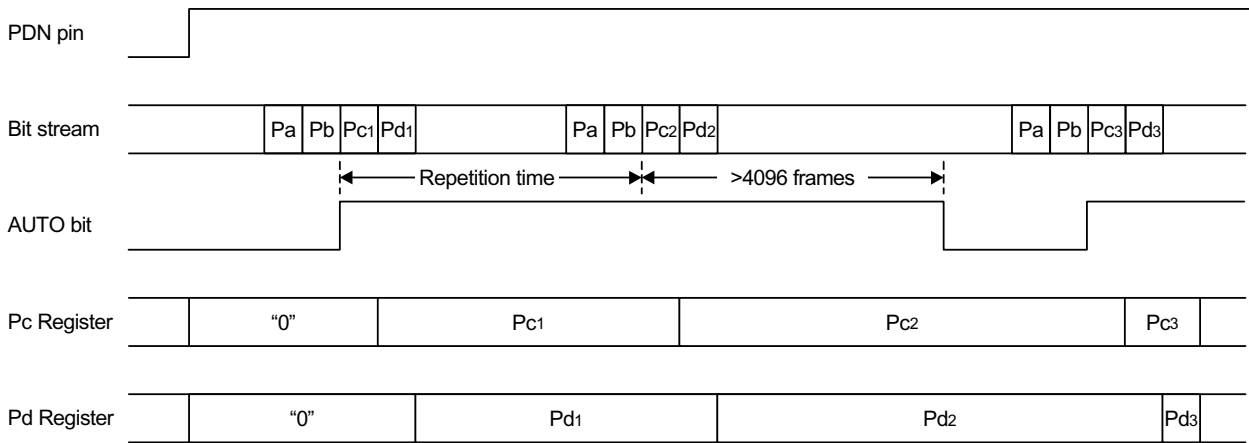

Figure 32. Timing example 1

2) When Non-PCM bitstream stops (when MULK0=0),

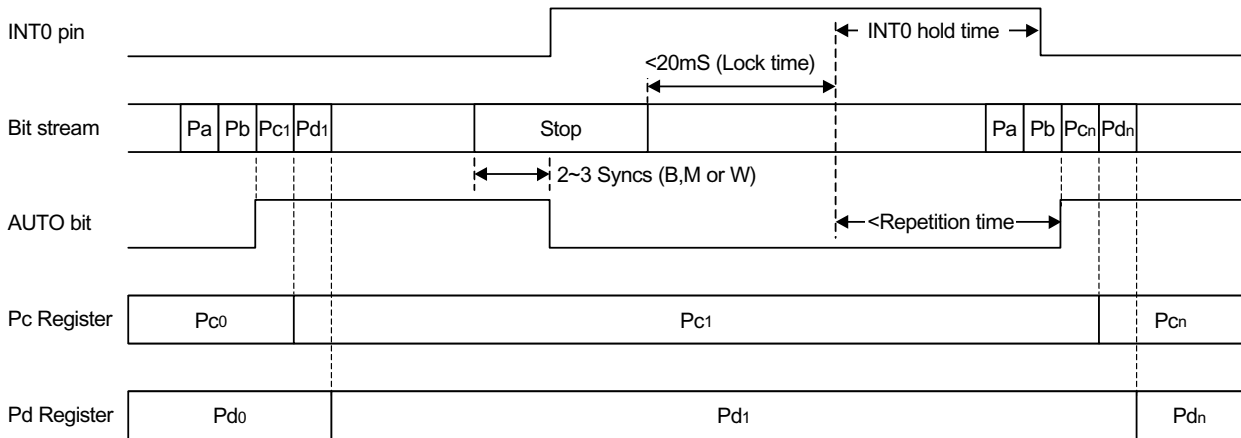

Figure 33. Timing example 2

**SYSTEM DESIGN**

Figure 34 shows the system connection diagram. An evaluation board is available which demonstrates application circuits, the optimum layout, power supply arrangements and measurement results.

Condition: TVDD=3.3V, Master mode, 4-wire serial control mode, DZFM2-0 = "100"

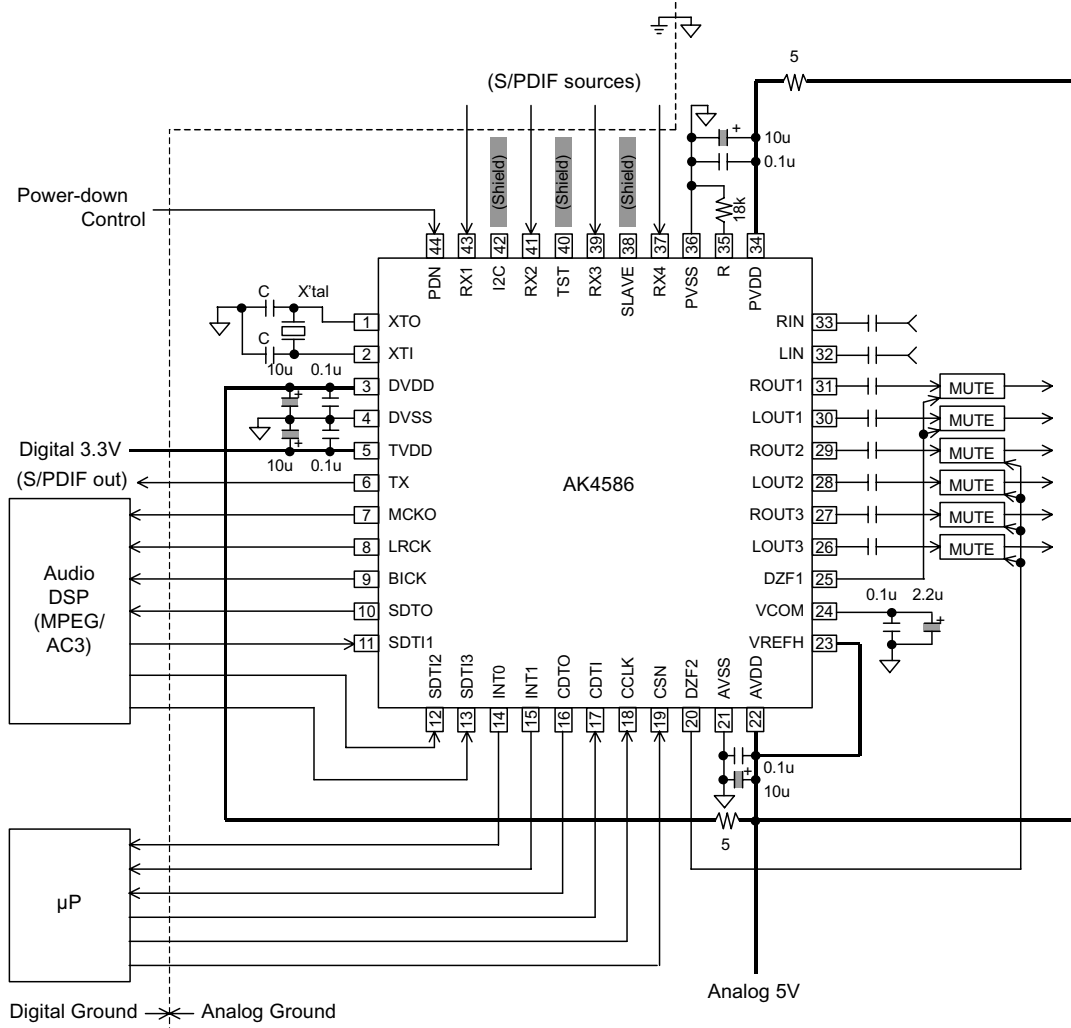

Figure 34. Typical Connection Diagram

Notes:

- "C" depends on the crystal.
- AVSS, DVSS and PVSS must be connected the same analog ground plane.
- Digital signals, especially clocks, should be kept away from the R pin in order to avoid an effect to the clock jitter performance.
- In case of coaxial input, ground of RCA connector and terminator should be connected to PVSS of the AK4586 with low impedance on PC board.

## 1. Grounding and Power Supply Decoupling

The AK4586 requires careful attention to power supply and grounding arrangements. AVDD, DVDD and PVDD are usually supplied from analog supply in system. Alternatively if AVDD, DVDD and PVDD are supplied separately, the power up sequence is not critical. **AVSS, DVSS and PVSS of the AK4586 must be connected to analog ground plane.** System analog ground and digital ground should be connected together near to where the supplies are brought onto the printed circuit board. Decoupling capacitors should be as near to the AK4586 as possible, with the small value ceramic capacitor being the nearest.

## 2. Voltage Reference Inputs

The voltage of VREFH sets the analog input/output range. VREFH pin is normally connected to AVDD with a 0.1 $\mu$ F ceramic capacitor. VCOM is a signal ground of this chip. An electrolytic capacitor 2.2 $\mu$ F parallel with a 0.1 $\mu$ F ceramic capacitor attached to VCOM pin eliminates the effects of high frequency noise. No load current may be drawn from VCOM pin. All signals, especially clocks, should be kept away from the VREFH and VCOM pins in order to avoid unwanted coupling into the AK4586.

## 3. Analog Inputs

ADC inputs are single-ended and internally biased to VCOM. The input signal range scales with the supply voltage and nominally 0.6 x VREFH Vpp (typ). The ADC output data format is 2's complement. The DC offset is removed by the internal HPF.

The AK4586 samples the analog inputs at 64fs. The digital filter rejects noise above the stop band except for multiples of 64fs. The AK4586 includes an anti-aliasing filter (RC filter) to attenuate a noise around 64fs.

## 4. Analog Outputs

The analog outputs are also single-ended and centered around the VCOM voltage. The input signal range scales with the supply voltage and nominally 0.6 x VREFH Vpp. The DAC input data format is 2's complement. The output voltage is a positive full scale for 7FFFFFFH(@24bit) and a negative full scale for 800000H(@24bit). The ideal output is VCOM voltage for 000000H(@24bit). The internal analog filters remove most of the noise generated by the delta-sigma modulator of DAC beyond the audio passband.

DC offsets on analog outputs are eliminated by AC coupling since DAC outputs have DC offsets of a few mV.

PACKAGE

44pin LQFP (Unit: mm)

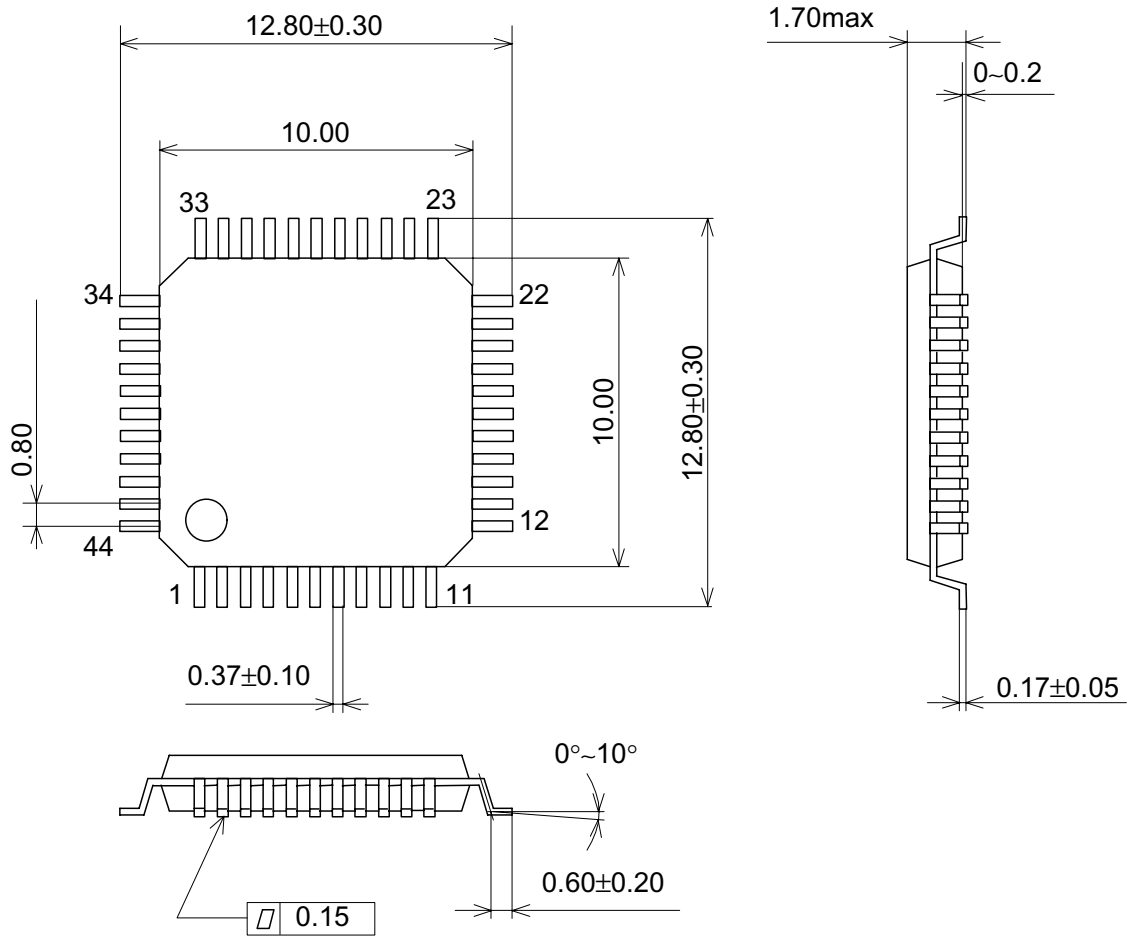

■ Package & Lead frame material

Package molding compound:	Epoxy
Lead frame material:	Cu
Lead frame surface treatment:	Solder plate

<b>MARKING</b>
----------------

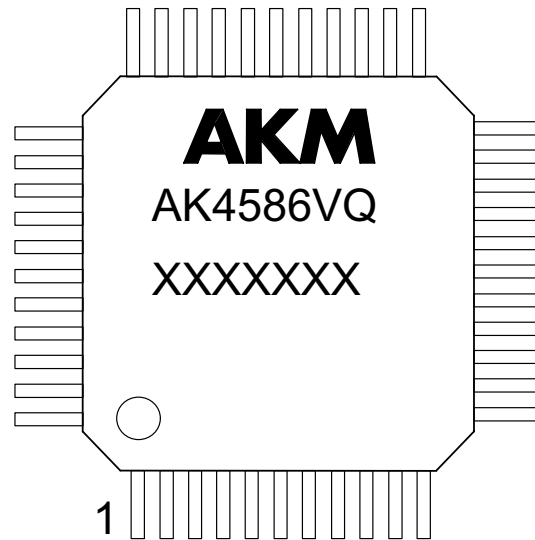

- 1) Pin #1 indication
- 2) Date Code: XXXXXXX(7 digits)
- 3) Marking Code: AK4586VQ
- 4) Asahi Kasei Logo

**IMPORTANT NOTICE**

- These products and their specifications are subject to change without notice. Before considering any use or application, consult the Asahi Kasei Microsystems Co., Ltd. (AKM) sales office or authorized distributor concerning their current status.
- AKM assumes no liability for infringement of any patent, intellectual property, or other right in the application or use of any information contained herein.
- Any export of these products, or devices or systems containing them, may require an export license or other official approval under the law and regulations of the country of export pertaining to customs and tariffs, currency exchange, or strategic materials.
- AKM products are neither intended nor authorized for use as critical components in any safety, life support, or other hazard related device or system, and AKM assumes no responsibility relating to any such use, except with the express written consent of the Representative Director of AKM. As used here:
  - (a) A hazard related device or system is one designed or intended for life support or maintenance of safety or for applications in medicine, aerospace, nuclear energy, or other fields, in which its failure to function or perform may reasonably be expected to result in loss of life or in significant injury or damage to person or property.
  - (b) A critical component is one whose failure to function or perform may reasonably be expected to result, whether directly or indirectly, in the loss of the safety or effectiveness of the device or system containing it, and which must therefore meet very high standards of performance and reliability.
- It is the responsibility of the buyer or distributor of an AKM product who distributes, disposes of, or otherwise places the product with a third party to notify that party in advance of the above content and conditions, and the buyer or distributor agrees to assume any and all responsibility and liability for and hold AKM harmless from any and all claims arising from the use of said product in the absence of such notification.

This datasheet has been downloaded from:

[www.DatasheetCatalog.com](http://www.DatasheetCatalog.com)

Datasheets for electronic components.



LittleDiode supplies new, hard to find or obsolete electronic components and semiconductors all over the world.

With over two million different components listed you are sure to find the part you need.

Feel free to visit us today at our online store:

[LittleDiode.com](http://LittleDiode.com)

Looking forward to providing you with the best possible service.