



Integrated Device Technology, Inc.

CMOS STATIC RAM 64K (16K x 4-BIT)

IDT7188S
IDT7188L

FEATURES:

- High-speed (equal access and cycle times)
 - Military: 25/35/45/55/70/85ns (max.)
- Low power consumption
- Battery backup operation — 2V data retention (L version only)
- Available in high-density industry standard 22-pin, 300 mil ceramic DIP
- Produced with advanced CMOS technology
- Inputs/outputs TTL-compatible
- Military product compliant to MIL-STD-883, Class B

DESCRIPTION:

The IDT7188 is a 65,536-bit high-speed static RAM organized as 16K x 4. It is fabricated using IDT's high-performance, high-reliability technology — CMOS. This state-of-the-art technology, combined with innovative circuit design

techniques, provides a cost effective approach for memory intensive applications.

Access times as fast as 25ns are available. The IDT7188 offers a reduced power standby mode, ISB_1 , which is activated when \overline{CS} goes HIGH. This capability significantly decreases power while enhancing system reliability. The low-power version (L) version also offers a battery backup data retention capability where the circuit typically consumes only 30 μ W operating from a 2V battery.

All inputs and outputs are TTL-compatible and operate from a single 5V supply. The IDT7188 is packaged in 22-pin, 300 mil ceramic DIP providing excellent board-level packing densities.

Military grade product is manufactured in compliance with the latest revision of MIL-STD-883, Class B, making it ideally suited to military temperature applications demanding the highest level of performance and reliability.

FUNCTIONAL BLOCK DIAGRAM

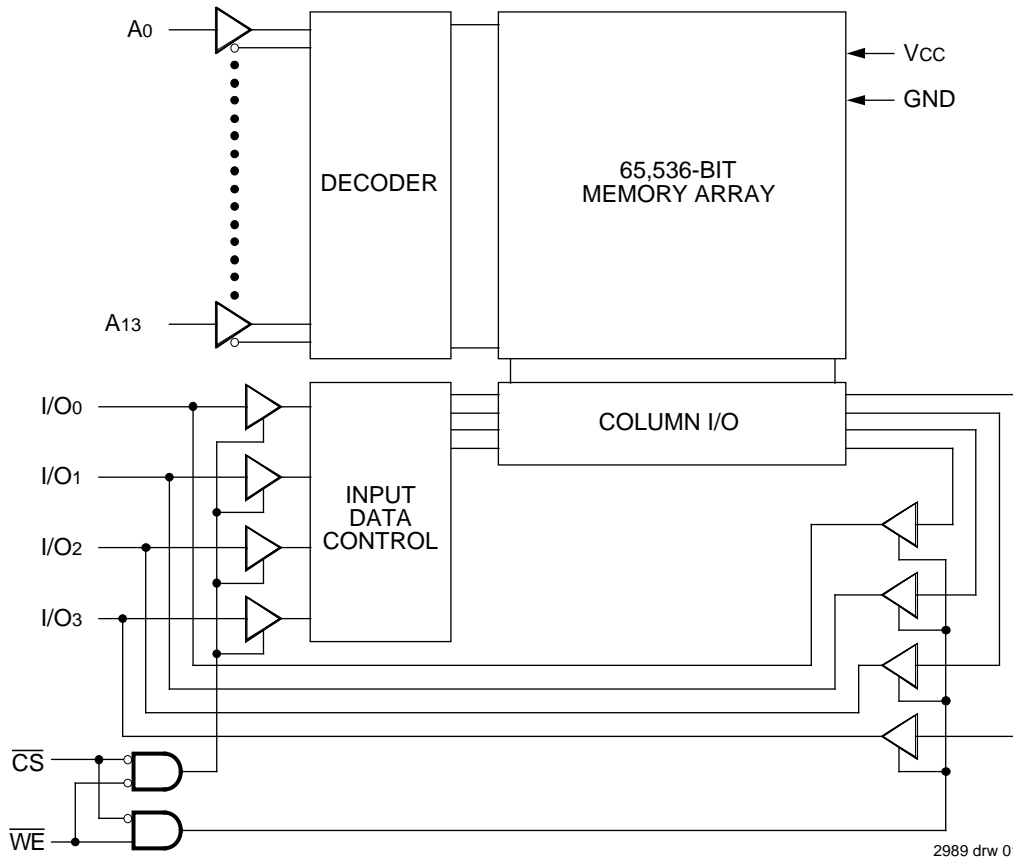

The IDT logo is a registered trademark of Integrated Device Technology, Inc.

MILITARY TEMPERATURE RANGE

AUGUST 1996

PIN CONFIGURATIONS

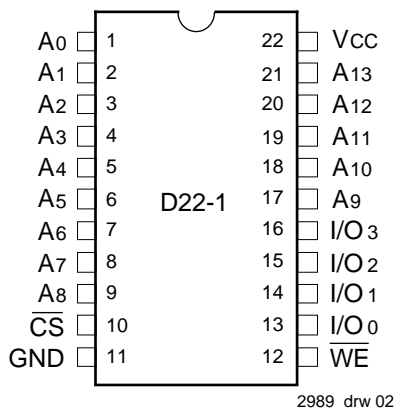

DIP
TOP VIEW

PIN DESCRIPTIONS

Name	Description
A ₀ –A ₁₃	Address Inputs
\overline{CS}	Chip Select
\overline{WE}	Write Enable
I/O ₀₋₃	Data Input/Output
V _{CC}	Power
GND	Ground

2989 tbl 01

TRUTH TABLE⁽¹⁾

Mode	\overline{CS}	\overline{WE}	I/O	Power
Standby	H	X	High Z	Standby
Read	L	H	DOUT	Active
Write	L	L	DIN	Active

NOTE:

1. H = V_{IH}, L = V_{IL}, X = don't care.

2989 tbl 02

ABSOLUTE MAXIMUM RATINGS⁽¹⁾

Symbol	Rating	Com'l.	Mil.	Unit
V _{TERM}	Terminal Voltage with Respect to GND	–0.5 to +7.0	–0.5 to +7.0	V
T _A	Operating Temperature	0 to +70	–55 to +125	°C
T _{BIAS}	Temperature Under Bias	–55 to +125	–65 to +135	°C
T _{STG}	Storage Temperature	–55 to +125	–65 to +150	°C
P _T	Power Dissipation	1.0	1.0	W
I _{OUT}	DC Output Current	50	50	mA

NOTE:

2989 tbl 03

1. Stresses greater than those listed under ABSOLUTE MAXIMUM RATINGS may cause permanent damage to the device. This is a stress rating only and functional operation of the device at these or any other conditions above those indicated in the operational sections of this specification is not implied. Exposure to absolute maximum rating conditions for extended periods may affect reliability.

CAPACITANCE (T_A = +25°C, f = 1.0MHz, V_{CC} = 0V)

Symbol	Parameter ⁽¹⁾	Conditions	Max.	Unit
C _{IN}	Input Capacitance	V _{IN} = 0V	6	pF
C _{I/O}	I/O Capacitance	V _{OUT} = 0V	6	pF

NOTE:

2989 tbl 04

1. This parameter is determined by device characterization, but is not production tested.

RECOMMENDED DC OPERATING CONDITIONS

Symbol	Parameter	Min.	Typ.	Max.	Unit
V _{CC}	Supply Voltage	4.5	5.0	5.5	V
GND	Supply Voltage	0	0	0	V
V _{IH}	Input High Voltage	2.2	—	6.0	V
V _{IL}	Input Low Voltage	–0.5 ⁽¹⁾	—	0.8	V

NOTE:

2989 tbl 05

1. V_{IL} (min.) = –3.0V for pulse width less than 20ns, once per cycle.

RECOMMENDED OPERATING TEMPERATURE AND SUPPLY VOLTAGE

Grade	Temperature	GND	V _{CC}
Military	–55°C to +125°C	0V	5V ± 10%
Commercial	0°C to +70°C	0V	5V ± 10%

2989 tbl 06

DC ELECTRICAL CHARACTERISTICS

V_{CC} = 5.0V ± 10%

Symbol	Parameter	Test Condition	IDT7188S		IDT7188L		Unit	
			Min.	Max.	Min.	Max.		
I _{LI}	Input Leakage Current	V _{CC} = Max., V _{IN} = GND to V _{CC}	MIL. COM'L.	— 10 5	— 5 2	— 5 2	μA	
I _{LO}	Output Leakage Current	V _{CC} = Max., \overline{CS} = V _{IH} , V _{OUT} = GND to V _{CC}	MIL. COM'L.	— 10 5	— 5 2	— 5 2	μA	
V _{OL}	Output Low Voltage	I _{OL} = 10mA, V _{CC} = Min.		—	0.5	—	0.5	V
		I _{OL} = 8mA, V _{CC} = Min.		—	0.4	—	0.4	
V _{OH}	Output High Voltage	I _{OH} = -4mA, V _{CC} = Min.		2.4	—	2.4	—	V

2989 tbl 07

DC ELECTRICAL CHARACTERISTICS⁽¹⁾

(V_{CC} = 5V ± 10%, V_{LC} = 0.2V, V_{HC} = V_{CC} - 0.2V)

Symbol	Parameter	Power	7188S25 7188L25		7188S35 7188L35		7188S45 7188L45		7188S55/70 7188L55/70		7188S85 7188L85		Unit
			Com'l.	Mil.	Com'l.	Mil.	Com'l.	Mil.	Com'l.	Mil.	Com'l.	Mil.	
I _{CC1}	Operating Power Supply Current \overline{CS} = V _{IL} , Outputs Open V _{CC} = Max., f = 0 ⁽²⁾	S	—	105	—	105	—	105	—	105	—	105	mA
		L	—	80	—	80	—	80	—	80	—	80	
I _{CC2}	Dynamic Operating Current \overline{CS} = V _{IL} , Outputs Open V _{CC} = Max., f = f _{MAX} ⁽²⁾	S	—	155	—	140	—	140	—	140	—	140	mA
		L	—	120	—	115	—	110	—	110	—	105	
I _{SB}	Standby Power Supply Current (TTL Level) \overline{CS} ≥ V _{IH} , V _{CC} = Max., Outputs Open, f = f _{MAX} ⁽²⁾	S	—	60	—	50	—	50	—	50	—	50	mA
		L	—	40	—	40	—	35	—	35	—	35	
I _{SB1}	Full Standby Power Supply Current (CMOS Level) \overline{CS} ≥ V _{HC} , V _{CC} = Max., V _{IN} ≥ V _{HC} or V _{IN} ≤ V _{LC} , f = 0 ⁽²⁾	S	—	20	—	20	—	20	—	20	—	20	mA
		L	—	1.5	—	1.5	—	1.5	—	1.5	—	1.5	

NOTES:

- All values are maximum guaranteed values.
- At f = f_{MAX} address and data inputs are cycling at the maximum frequency of read cycles of 1/trc. f = 0 means no input lines change.

2989 tbl 08

DATA RETENTION CHARACTERISTICS OVER ALL TEMPERATURE RANGES

(L Version Only) $V_{HC} = V_{CC} - 0.2V$

Symbol	Parameter	Test Condition	Min.	Typ. ⁽¹⁾ V _{CC} @		Max. V _{CC} @		Unit
				2.0v	3.0V	2.0V	3.0V	
V _{DR}	V _{CC} for Data Retention	—	2.0	—	—	—	—	V
I _{CCDR}	Data Retention Current	MIL. COM'L.	—	10	15	600	900	μA
			—	10	15	150	225	
t _{CDR} ⁽³⁾	Chip Deselect to Data Retention Time	$\overline{CS} \geq V_{HC}$ $V_{IN} \geq V_{HC}$ or $\leq V_{LC}$	0	—	—	—	—	ns
t _R ⁽³⁾	Operation Recovery Time		t _{RC} ⁽²⁾	—	—	—	—	ns
I _{LI} ⁽³⁾	Input Leakage Current		—	—	—	2	2	μA

NOTES:

- TA = +25°C.
- t_{RC} = Read Cycle Time.
- This parameter is guaranteed by device characterization but is not production tested.

2989 tbl 09

LOW V_{CC} DATA RETENTION WAVEFORM

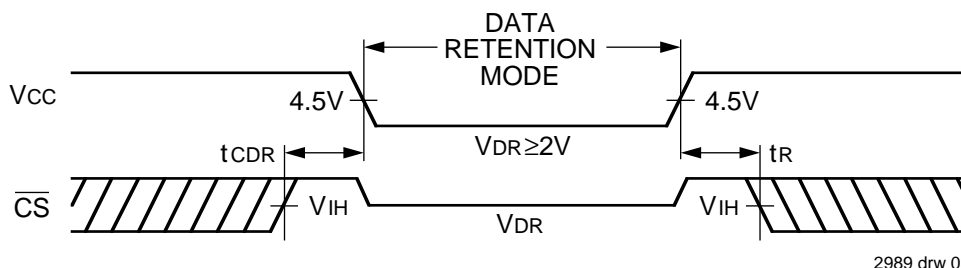

2989 drw 03

AC TEST CONDITIONS

Input Pulse Levels	GND to 3.0V
Input Rise/Fall Times	5ns
Input Timing Reference Levels	1.5V
Output Reference Levels	1.5V
AC Test Load	See Figures 1 and 2

2989 tbl 10

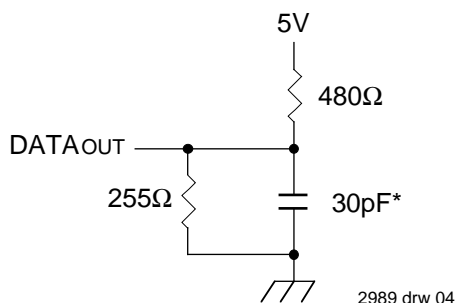

2989 drw 04

Figure 1. AC Test Load

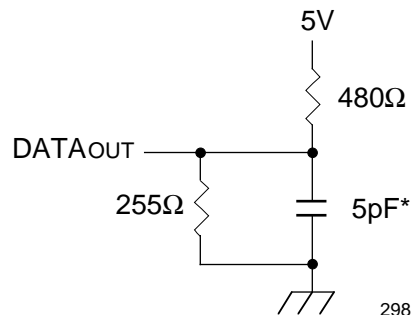

2989 drw 05

Figure 2. AC Test Load
(for t_{HZ}, t_{LZ}, t_{WZ}, t_{OHZ} and t_{OW})

*Includes scope and jig capacitances

AC ELECTRICAL CHARACTERISTICS ($V_{CC} = 5.0V \pm 10\%$, All Temperature Ranges)

Symbol	Parameter	7188S25 7188L25		7188S35/45 7188L35/45		7188S55/70 7188L55/70		7188S85 7188L85		Unit
		Min.	Max.	Min.	Max.	Min.	Max.	Min.	Max.	
Read Cycle										
t _{RC}	Read Cycle Time	25	—	35/45	—	55/70	—	85	—	ns
t _{AA}	Address Access Time	—	25	—	35/45	—	55/70	—	85	ns
t _{ACS}	Chip Select Access Time	—	25	—	35/45	—	55/70	—	85	ns
t _{OH}	Output Hold from Address Change	5	—	5	—	5	—	5	—	ns
t _{LZ} ⁽¹⁾	Output Selection to Output in Low-Z	5	—	5	—	5	—	5	—	ns
t _{HZ} ⁽¹⁾	Chip Deselect to Output in High-Z	—	10	—	14	—	20/25	—	30	ns
t _{PU} ⁽¹⁾	Chip Select to Power Up Time	0	—	0	—	0	—	0	—	ns
t _{PD} ⁽¹⁾	Chip Deselect to Power Down Time	—	25	—	35/45	—	55/70	—	85	ns

NOTES:

2989 tbl 11

1. This parameter is guaranteed by device characterization but is not production tested.

TIMING WAVEFORM OF READ CYCLE NO. 1^(1, 2)

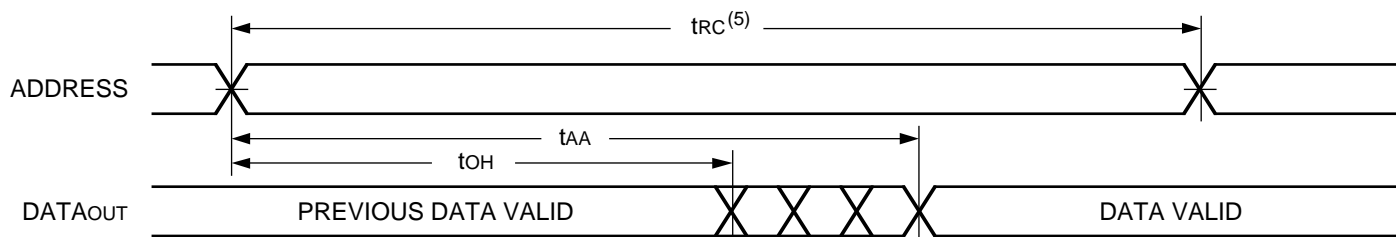

2989 drw 06

TIMING WAVEFORM OF READ CYCLE NO. 2^(1, 3)

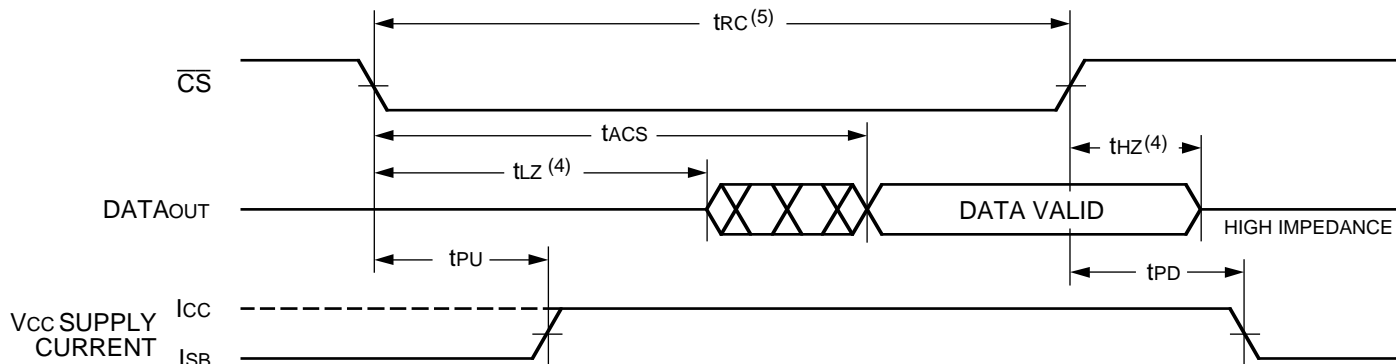

2989 drw 07

NOTES:

1. \overline{WE} is HIGH for Read cycle.
2. \overline{CS} is LOW for Read cycle.
3. Address valid prior to or coincident with \overline{CS} transition LOW.
4. Transition is measured $\pm 200mV$ from steady state voltage.
5. All Read cycle timings are referenced from the last valid address to the first transitioning address.

AC ELECTRICAL CHARACTERISTICS ($V_{CC} = 5.0V \pm 10\%$, All Temperature Ranges)

Symbol	Parameter	7188S25 7188L25		7188S35/45 7188L35/45		7188S55/70 7188L55/70		7188S85 7188L85		Unit
		Min.	Max.	Min.	Max.	Min.	Max.	Min.	Max.	
Write Cycle										
t _{WC}	Write Cycle Time	20	—	30/40	—	50/60	—	75	—	ns
t _{CW}	Chip Select to End-of-Write	20	—	25/35	—	50/60	—	75	—	ns
t _{AW}	Address Valid to End-of-Write	20	—	25/35	—	50/60	—	75	—	ns
t _{AS}	Address Set-up Time	0	—	0	—	0	—	0	—	ns
t _{WP}	Write Pulse Width	20	—	25/35	—	50/60	—	75	—	ns
t _{WR}	Write Recovery Time	0	—	0	—	0	—	0	—	ns
t _{DW}	Data Valid to End-of-Write	13	—	15/20	—	25/30	—	35	—	ns
t _{DH}	Data Hold Time	0	—	0	—	0	—	0	—	ns
t _{WZ} ⁽¹⁾	Write Enable to Output in High-Z	—	7	—	10/15	—	25/30	—	40	ns
t _{OW} ⁽¹⁾	Output Active from End-of-Write	5	—	5	—	5	—	5	—	ns

NOTES:

1. This parameter is guaranteed by device characterization.

2989 tbi 12

TIMING WAVEFORM OF WRITE CYCLE NO. 1 (\overline{WE} CONTROLLED TIMING)^(1, 2, 3)

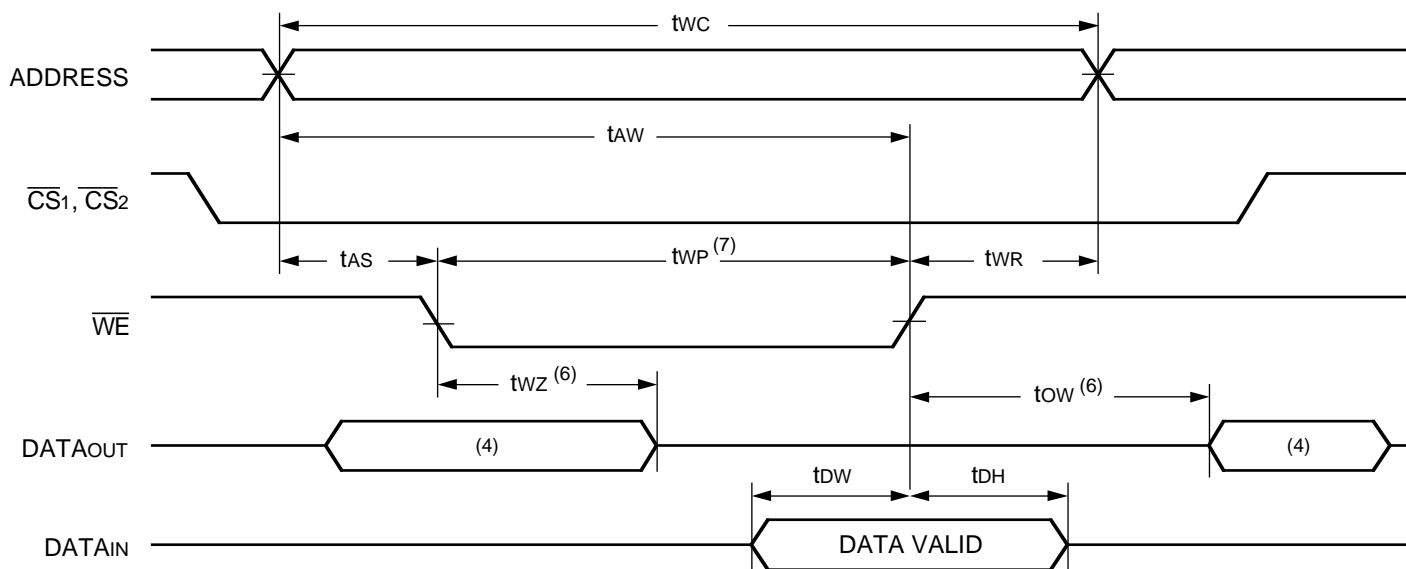

2989 drw 08

NOTES:

1. \overline{WE} or \overline{CS} must be HIGH during all address transitions.
2. A write occurs during the overlap (t_{WP}) of a LOW \overline{CS} and a LOW \overline{WE} .
3. t_{WR} is measured from the earlier of \overline{CS} or \overline{WE} going HIGH to the end of the write cycle.
4. During this period, I/O pins are in the output state so that the input signals should not be applied.
5. If the \overline{CS} LOW transition occurs simultaneously with or after the \overline{WE} LOW transition, the outputs remain in the high-impedance state.
6. Transition is measured $\pm 200mV$ from steady state.

TIMING WAVEFORM OF WRITE CYCLE NO. 2 (\overline{CS} CONTROLLED TIMING)^(1,2,3,5)

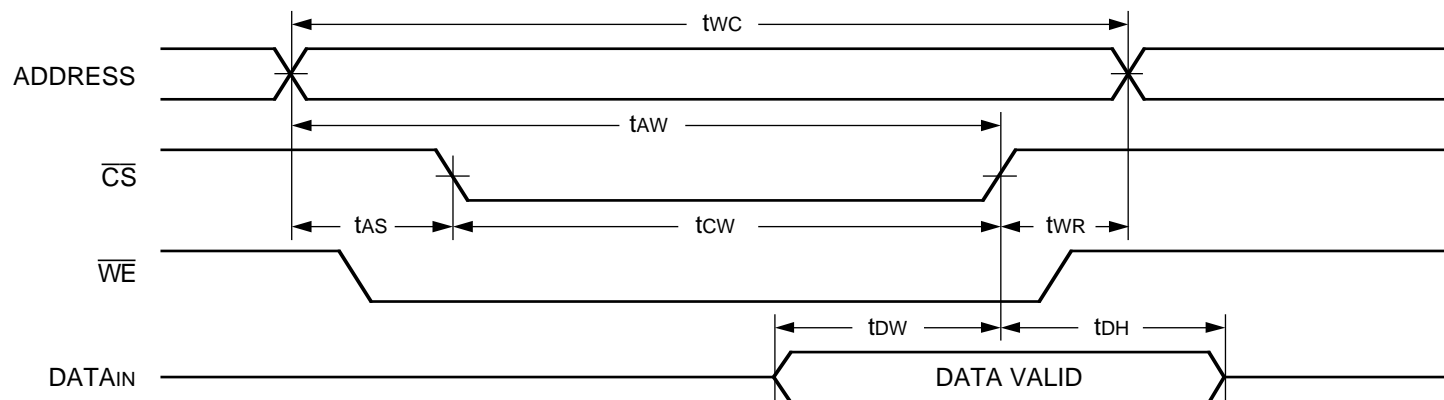

2989 drw 09

NOTES:

- \overline{WE} or \overline{CS} must be HIGH during all address transitions.
- A write occurs during the overlap (t_{WP}) of a LOW \overline{CS} and a LOW \overline{WE} .
- t_{WR} is measured from the earlier of \overline{CS} or \overline{WE} going HIGH to the end of the write cycle.
- During this period, I/O pins are in the output state so that the input signals should not be applied.
- If the \overline{CS} LOW transition occurs simultaneously with or after the \overline{WE} LOW transition, the outputs remain in the high-impedance state.
- Transition is measured $\pm 200\text{mV}$ from steady state.

ORDERING INFORMATION

IDT7188	X	XX	X	X	
Device Type	Power	Speed	Package	Process/ Temperature Range	
				B	Military (-55°C to +125°C) Compliant to MIL-STD-883, Class B
			D		300 mil Ceramic DIP (D22-1)
		25 35 45 55 70 85			} Speed in nanoseconds
	S L				

2989 drw 10

This datasheet has been downloaded from:

www.DatasheetCatalog.com

Datasheets for electronic components.



LittleDiode supplies new, hard to find or obsolete electronic components and semiconductors all over the world.

With over two million different components listed you are sure to find the part you need.

Feel free to visit us today at our online store:

LittleDiode.com

Looking forward to providing you with the best possible service.