



CMOS Static RAM 256K (64K x 4-Bit)

IDT61298SA

Features

- ◆ 64K x 4 high-speed static RAM
- ◆ Fast Output Enable (\overline{OE}) pin available for added system flexibility
- ◆ High speed (equal access and cycle times)
 - Commercial: 12/15 ns (max.)
- ◆ JEDEC standard pinout
- ◆ 300 mil 28-pin SOJ
- ◆ Produced with advanced CMOS technology
- ◆ Bidirectional data inputs and outputs
- ◆ Inputs/Outputs TTL-compatible
- ◆ Three-state outputs
- ◆ Military product compliant to MIL-STD-883, Class B

Description

The IDT61298SA is a 262,144-bit high-speed static RAM organized as 64K x 4. It is fabricated using IDT's high-performance, high-reliability

CMOS technology. This state-of-the-art technology, combined with innovative circuit design techniques, provides a cost-effective approach for memory intensive applications.

The IDT61298SA features two memory control functions: Chip Select (\overline{CS}) and Output Enable (\overline{OE}). These two functions greatly enhance the IDT61298SA's overall flexibility in high-speed memory applications.

Access times as fast as 12ns are available. The IDT61298SA offers a reduced power standby mode, $ISB1$, which enables the designer to considerably reduce device power requirements. This capability significantly decreases system power and cooling levels, while greatly enhancing system reliability.

All inputs and outputs are TTL-compatible and the device operates from a single 5V supply. Fully static asynchronous circuitry, along with matching access and cycle times, favor the simplified system design approach.

The IDT61298SA is packaged in a 300 mil, 28-pin SOJ, providing improved board-level packing densities.

Functional Block Diagram

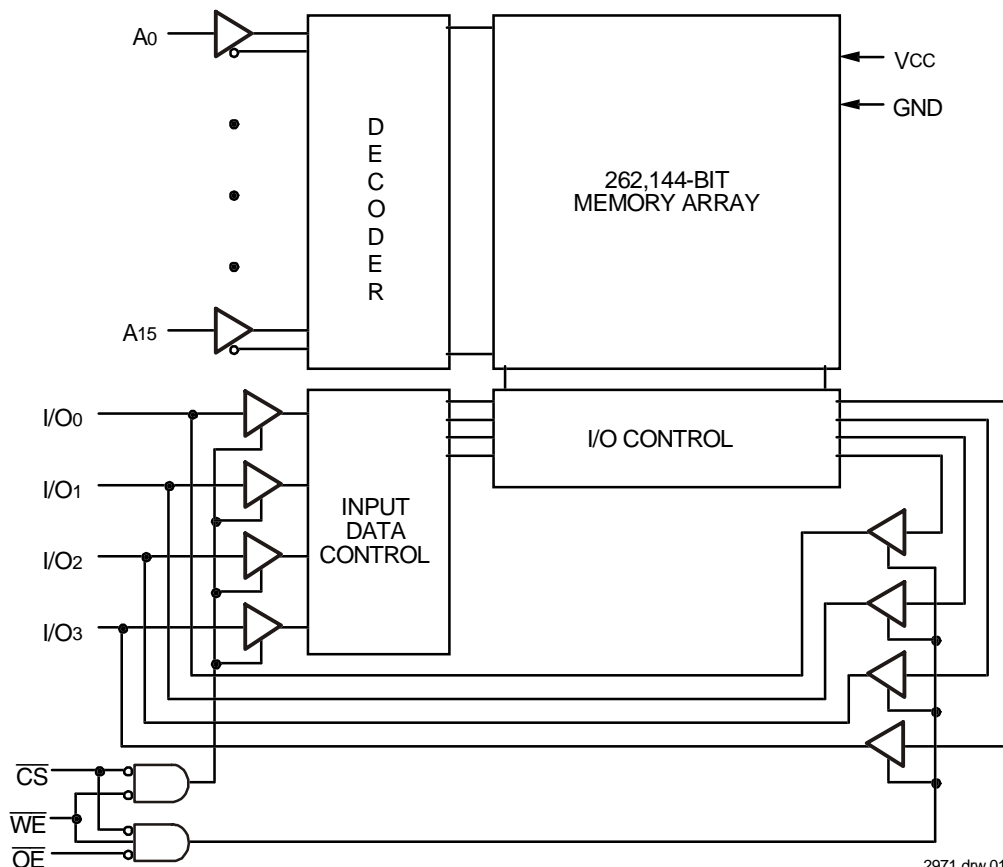

FEBRUARY 2001

Pin Configuration

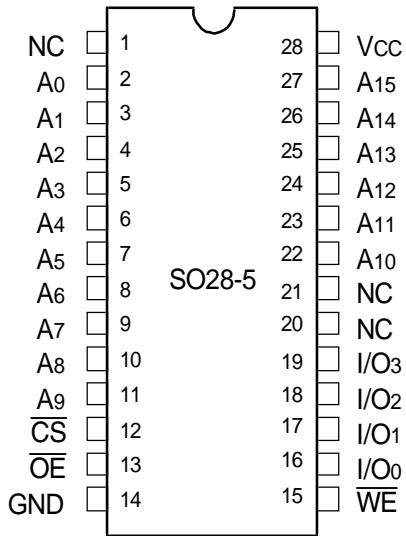

2971 drw 02

SOJ Top View

Pin Descriptions

Name	Description
A0 - A14	Addresses
I/O0 - I/O7	Data Input/Output
\overline{CS}	Chip Select
\overline{WE}	Write Enable
\overline{OE}	Output Enable
GND	Ground
V _{CC}	Power

2971 tbl 01

Truth Table^(1,2)

\overline{CS}	\overline{OE}	\overline{WE}	I/O	Function
L	L	H	DATA _{OUT}	Read Data
L	X	L	DATA _{IN}	Write Data
L	H	H	High-Z	Outputs Disabled
H	X	X	High-Z	Deselected - Standby (Isb)
V _{Hc} ⁽³⁾	X	X	High-Z	Deselected - Standby (Isb1)

2971 tbl 02

NOTES:

- H = V_{IH}, L = V_{IL}, x = Don't care.
- V_{LC} = 0.2V, V_{HC} = V_{CC} - 0.2V.
- Other inputs $\geq V_{HC}$ or $\leq V_{LC}$.

Absolute Maximum Ratings⁽¹⁾

Symbol	Rating	Com'l.	Unit
V _{TERM} ⁽²⁾	Terminal Voltage with Respect to GND	-0.5 to +7.0	V
T _A	Operating Temperature	0 to +70	°C
T _{BIAS}	Temperature Under Bias	-55 to +125	°C
T _{STG}	Storage Temperature	-55 to +125	°C
P _T	Power Dissipation	1.0	W
I _{OUT}	DC Output Current	50	mA

2971 tbl 03

NOTES:

- Stresses greater than those listed under ABSOLUTE MAXIMUM RATINGS may cause permanent damage to the device. This is a stress rating only and functional operation of the device at these or any other conditions above those indicated in the operational sections of this specification is not implied. Exposure to absolute maximum rating conditions for extended periods may affect reliability.
- V_{TERM} must not exceed V_{CC} + 0.5V.

Capacitance

(TA = +25°C, f = 1.0MHz, SOJ Package)

Symbol	Parameter ⁽¹⁾	Conditions	Max.	Unit
C _{IN}	Input Capacitance	V _{IN} = 3dV	5	pF
C _{OUT}	Output Capacitance	V _{OUT} = 3dV	7	pF

2971 tbl 04

NOTE:

- This parameter is determined by device characterization, but is not production tested.

Recommended Operating Temperature and Supply Voltage

Grade	Temperature	GND	Vcc
Commercial	0°C to +70°C	0V	5V ± 10%

2971 tbl 05

Recommended DC Operating Conditions

Symbol	Parameter	Min.	Typ.	Max.	Unit
V _{CC}	Supply Voltage	4.5	5.0	5.5	V
GND	Ground	0	0	0	V
V _{IH}	Input High Voltage	2.2	—	V _{CC} + 0.5V	V
V _{IL}	Input Low Voltage	-0.5 ⁽¹⁾	—	0.8	V

2971 tbl 06

NOTE:

- V_{IL} (min.) = -1.5V for pulse width less than 10ns, once per cycle.

DC Electrical Characteristics⁽¹⁾ (V_{CC} = 5V ± 10%, V_{LC} = 0.2V, V_{HC} = V_{CC} - 0.2V)

Symbol	Parameter	61298SA12	61298SA15	Unit
		Com'l.	Com'l.	
I _{CC}	Dynamic Operating Current $\overline{CS} \leq V_{IL}$, Outputs Open, V _{CC} = Max., f = f _{MAX} ⁽²⁾	160	140	mA
I _{SB}	Standby Power Supply Current (TTL Level) $\overline{CS} \geq V_{IH}$, V _{CC} = Max., Outputs Open, f = f _{MAX} ⁽²⁾	50	45	mA
I _{SB1}	Full Standby Power Supply Current (CMOS Level) $\overline{CS} \geq V_{HC}$, V _{CC} = Max., f = 0 ⁽²⁾ , V _{IN} ≤ V _{LC} or V _{IN} ≥ V _{HC}	20	20	mA

2971 tbl 07

NOTES:

- All values are maximum guaranteed values.
- f_{MAX} = 1/trc (all address inputs are cycling at f_{MAX}); f = 0 means no address input lines are changing.

AC Test Conditions

Input Pulse Levels	GND to 3.0V
Input Rise/Fall Times	3ns
Input Timing Reference Levels	1.5V
Output Reference Levels	1.5V
AC Test Load	See Figures 1 and 2

2971 tbl 08

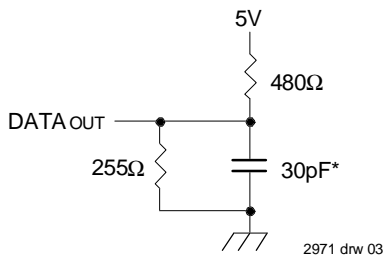

Figure 1. AC Test Load

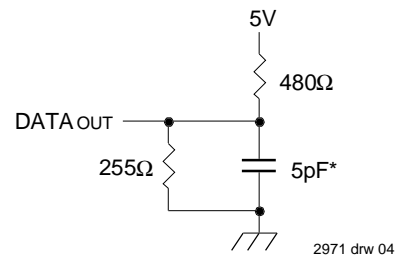

Figure 2. AC Test Load
(for t_{CLZ}, t_{OLZ}, t_{CHZ}, t_{OHZ}, t_{OW}, t_{WHZ})

*Includes scope and jig capacitances

DC Electrical Characteristics (V_{CC} = 5.0V ± 10%)

Symbol	Parameter	Test Conditions	IDT61298SA			Unit
			Min.	Typ.	Max.	
I _{IL}	Input Leakage Current	V _{CC} = Max., V _{IN} = GND to V _{CC}	—	—	5	μA
I _{LO}	Output Leakage Current	V _{CC} = Max., $\overline{CS} = V_{IH}$, V _{OUT} = GND to V _{CC}	—	—	5	μA
V _{OL}	Output Low Voltage	I _{OL} = 8mA, V _{CC} = Min. I _{OL} = 10mA, V _{CC} = Min.	—	—	0.4 0.5	V
V _{OH}	Output High Voltage	I _{OH} = -4mA, V _{CC} = Min.	2.4	—	—	V

2971 tbl 09

AC Electrical Characteristics (V_{CC} = 5.0V ± 10%)

Symbol	Parameter	61298SA12		61298SA15		Unit
		Min.	Max.	Min.	Max.	
Read Cycle						
t _{RC}	Read Cycle Time	12	—	15	—	ns
t _{AA}	Address Access Time	—	12	—	15	ns
t _{ACS}	Chip Select Access Time	—	12	—	15	ns
t _{CLZ} ⁽¹⁾	Chip Select to Output in Low-Z	4	—	4	—	ns
t _{CHZ} ⁽¹⁾	Chip Deselect to Output in High-Z	—	6	—	7	ns
t _{OE}	Output Enable to Output Valid	—	6	—	7	ns
t _{OLZ} ⁽¹⁾	Output Enable to Output in Low-Z	0	—	0	—	ns
t _{OHZ} ⁽¹⁾	Output Disable to Output in High-Z	—	6	—	6	ns
t _{OH}	Output Hold from Address Change	3	—	3	—	ns
t _{PU} ⁽¹⁾	Chip Select to Power-Up Time	0	—	0	—	ns
t _{PD} ⁽¹⁾	Chip Deselect to Power-Down Time	—	12	—	15	ns
Write Cycle						
t _{WC}	Write Cycle Time	12	—	15	—	ns
t _{CW}	Chip Select to End-of-Write	9	—	10	—	ns
t _{AW}	Address Valid to End-of-Write	9	—	10	—	ns
t _{AS}	Address Set-up Time	0	—	0	—	ns
t _{WP}	Write Pulse Width	9	—	10	—	ns
t _{WR}	Write Recovery Time	0	—	0	—	ns
t _{DW}	Data Valid to End-of-Write	6	—	7	—	ns
t _{DH}	Data Hold Time	0	—	0	—	ns
t _{WHZ} ⁽¹⁾	Write Enable to Output in High-Z	—	6	—	6	ns
t _{OW} ⁽¹⁾	Output Active from End-of-Write	4	—	4	—	ns

2971 tbl 10

NOTE:

1. This parameter is guaranteed with AC test load (Figure 2) by device characterization, but is not production tested.

Timing Waveform of Read Cycle No. 1⁽¹⁾

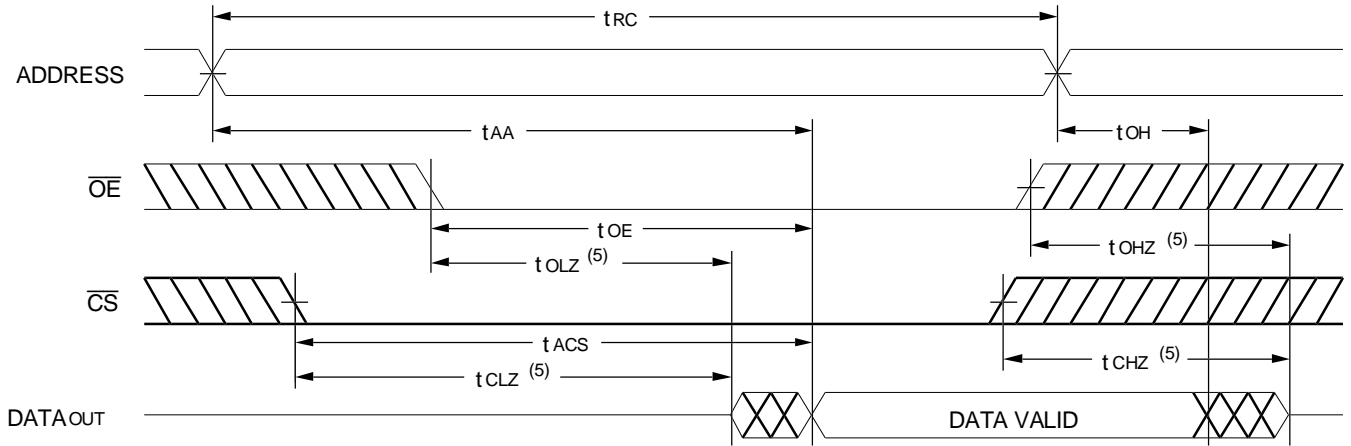

2971 drw 05

Timing Waveform of Read Cycle No. 2^(1,2,4)

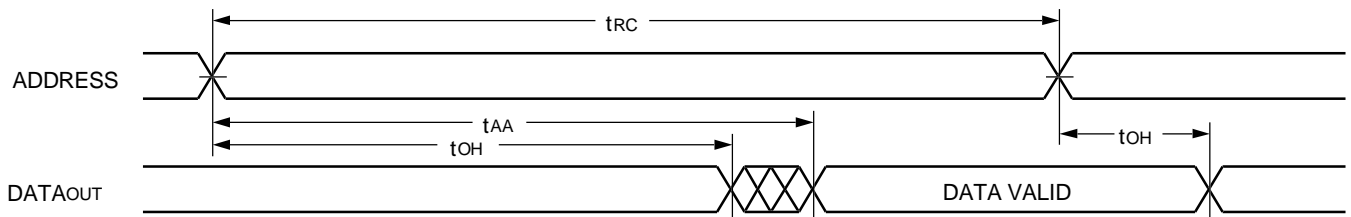

2971 drw 06

Timing Waveform of Read Cycle No. 3^(1,3,4)

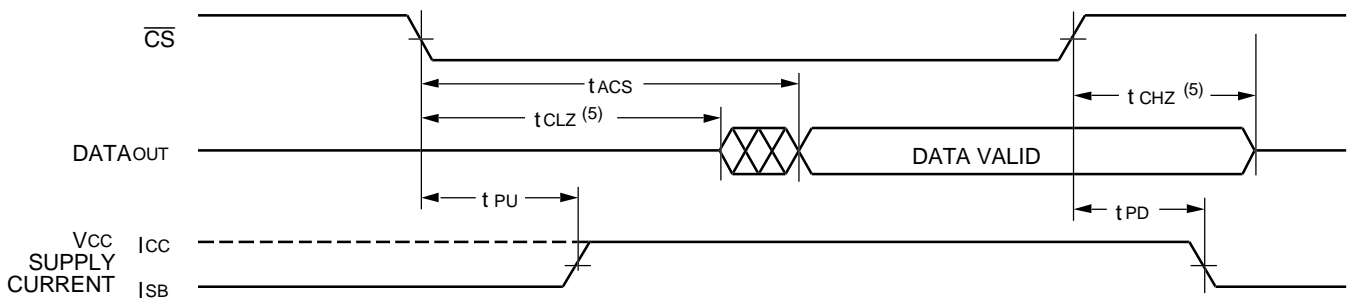

2971 drw 07

NOTES:

1. \overline{WE} is HIGH for Read cycle.
2. Device is continuously selected, \overline{CS} is LOW.
3. Address valid prior to or coincident with \overline{CS} transition LOW.
4. \overline{OE} is LOW.
5. Transition is measured $\pm 200\text{mV}$ from steady state.

Timing Waveform of Write Cycle No. 1 (\overline{WE} Controlled Timing)^(1,2,4)

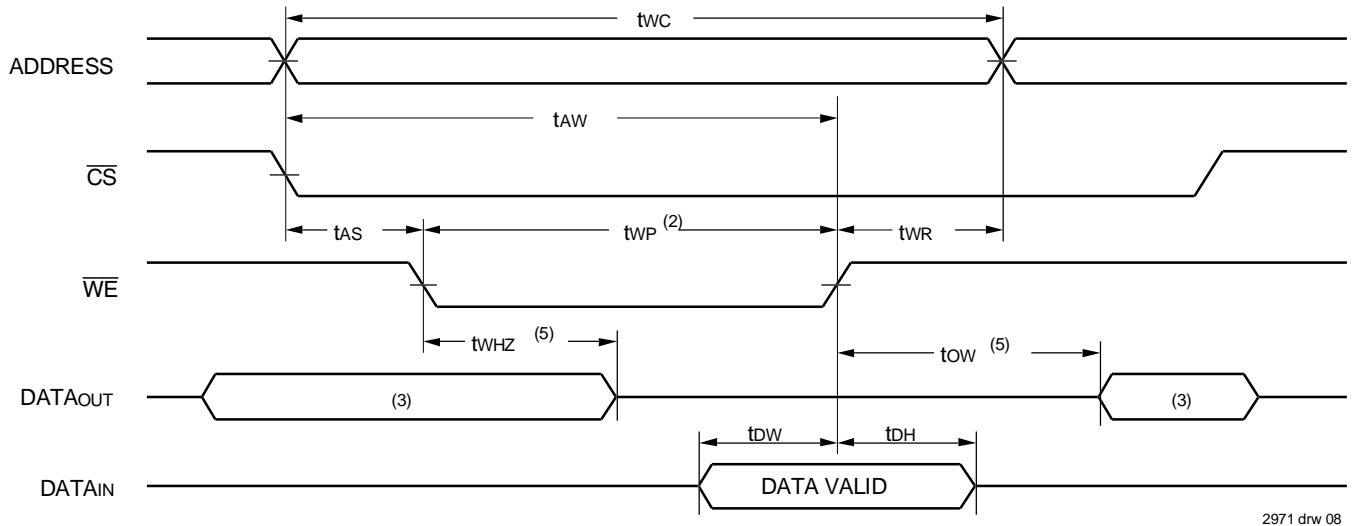

Timing Waveform of Write Cycle No. 2 (\overline{CS} Controlled Timing)^(1,4)

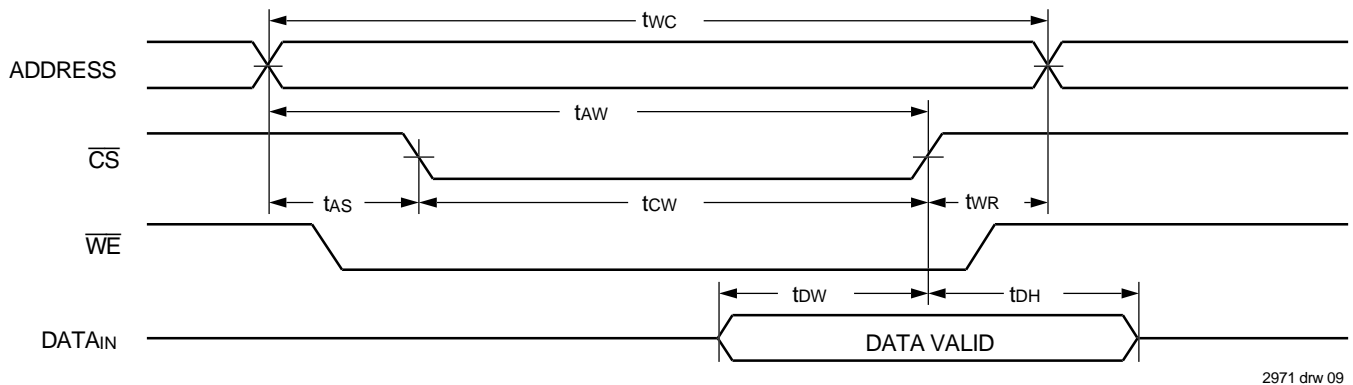

NOTES:

1. A write occurs during the overlap of a LOW \overline{CS} and a LOW \overline{WE} .
2. \overline{OE} is continuously HIGH. If \overline{OE} is LOW during a \overline{WE} controlled write cycle, the write pulse width must be the greater than or equal to $t_{WHZ} + t_{OW}$ to allow the I/O drivers to turn off and data to be placed on the bus for the required t_{OW} . If \overline{OE} is HIGH during a \overline{WE} controlled write cycle, this requirement does not apply and the minimum write pulse is as short as the specified t_{WP} .
3. During this period, I/O pins are in the output state so that the input signals must not be applied.
4. If the \overline{CS} LOW transition occurs simultaneously with or after the \overline{WE} LOW transition, the outputs remain in a high-impedance state.
5. Transition is measured $\pm 200\text{mV}$ from steady state.

Ordering Information

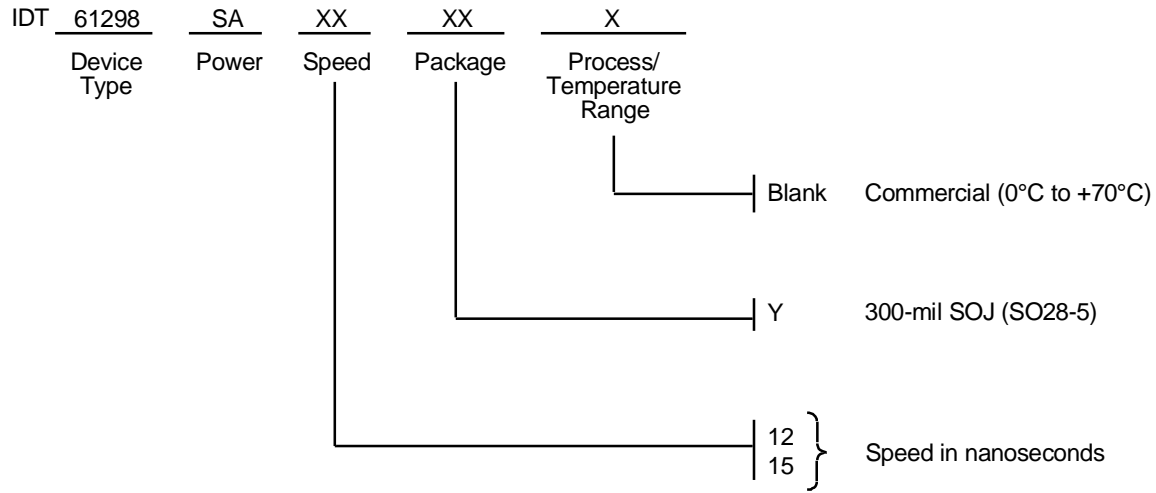

2971 drw 10

Datasheet Document History

11/22/99:		Updated to new format
	Pg. 6	Removed Note No. 1 Write Cycle No. 1 diagram, renumbered notes and footnotes
	Pg. 7	Added Datasheet Document History
08/09/00		Not recommended for new designs
02/01/01		Removed "Not recommended for new designs"



CORPORATE HEADQUARTERS
2975 Stender Way
Santa Clara, CA 95054

for SALES:
800-345-7015 or 408-727-6116
fax:408-492-8674
www.idt.com

for Tech Support:
sramhelp@idt.com
800 544-7726, x4033

The IDT logo is a registered trademark of Integrated Device Technology, Inc.



LittleDiode supplies new, hard to find or obsolete electronic components and semiconductors all over the world.

With over two million different components listed you are sure to find the part you need.

Feel free to visit us today at our online store:

LittleDiode.com

Looking forward to providing you with the best possible service.