

April 1995

Features

- 20A, 400V and 500V
- $V_{CE(ON)}$ 2.5V Max.
- T_{FALL} 1 μ s, 0.5 μ s
- Low On-State Voltage
- Fast Switching Speeds
- High Input Impedance
- Anti-Parallel Diode

Applications

- Power Supplies
- Motor Drives
- Protective Circuits

Description

The HGTH20N40C1D, HGTH20N40E1D, HGTH20N50C1D, and HGTH20N50E1D are n-channel enhancement-mode insulated gate bipolar transistors (IGBTs) designed for high voltage, low on-dissipation applications such as switching regulators and motor drivers. They feature a discrete anti-parallel diode that shunts current around the IGBT in the reverse direction without introducing carriers into the depletion region. These types can be operated directly from low power integrated circuits.

Package

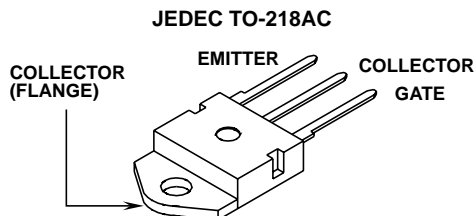

Terminal Diagram

N-CHANNEL ENHANCEMENT MODE

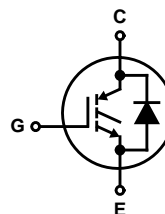

PACKAGING AVAILABILITY

PART NUMBER	PACKAGE	BRAND
HGTH20N40C1D	TO-218AC	G20N40C1D
HGTH20N40E1D	TO-218AC	G20N40E1D
HGTH20N50C1D	TO-218AC	G20N50C1D
HGTH20N50E1D	TO-218AC	G20N50E1D

NOTE: When ordering, use the entire part number.

Absolute Maximum Ratings $T_C = +25^\circ\text{C}$, Unless Otherwise Specified

	HGTH20N40C1D HGTH20N40E1D	HGTH20N50C1D HGTH20N50E1D	UNITS
Collector-Emitter Voltage	400	500	V
Collector-Gate Voltage $R_{GE} = 1M\Omega$	400	500	V
Gate-Emitter Voltage	± 20	± 20	V
Collector Current Continuous	20	20	A
Collector Current Pulsed	35	35	A
Diode Forward Current Continuous at $T_C = +25^\circ\text{C}$	35	35	A
at $T_J = +90^\circ\text{C}$	20	20	A
Power Dissipation Total at $T_C = +25^\circ\text{C}$	100	100	W
Power Dissipation Derating $T_C > +25^\circ\text{C}$	0.8	0.8	W/ $^\circ\text{C}$
Operating and Storage Junction Temperature Range	-55 to +150	-55 to +150	$^\circ\text{C}$

INTERSIL CORPORATION IGBT PRODUCT IS COVERED BY ONE OR MORE OF THE FOLLOWING U.S. PATENTS:

4,364,073	4,417,385	4,430,792	4,443,931	4,466,176	4,516,143	4,532,534	4,567,641
4,587,713	4,598,461	4,605,948	4,618,872	4,620,211	4,631,564	4,639,754	4,639,762
4,641,162	4,644,637	4,682,195	4,684,413	4,694,313	4,717,679	4,743,952	4,783,690
4,794,432	4,801,986	4,803,533	4,809,045	4,809,047	4,810,665	4,823,176	4,837,606
4,860,080	4,883,767	4,888,627	4,890,143	4,901,127	4,904,609	4,933,740	4,963,951
4,969,027							

Specifications HGTH20N40C1D, HGTH20N40E1D, HGTH20N50C1D, HGTH20N50E1D

Electrical Specifications $T_C = +25^\circ\text{C}$, Unless Otherwise Specified

PARAMETERS	SYMBOL	TEST CONDITIONS	LIMITS				UNITS	
			HGTH20N40C1D, HGTH20N40E1D		HGTH20N50C1D, HGTH20N50E1D			
			MIN	MAX	MIN	MAX		
Collector-Emitter Breakdown Voltage	BV_{CES}	$I_C = 1\text{mA}, V_{GE} = 0$	400	-	500	-	V	
Gate Threshold Voltage	$V_{GE(TH)}$	$V_{GE} = V_{CE}, I_C = 1\text{mA}$	2.0	4.5	2.0	4.5	V	
Zero Gate Voltage Collector Current	I_{CES}	$V_{CE} = 400\text{V}, T_C = +25^\circ\text{C}$	-	250	-	-	μA	
		$V_{CE} = 500\text{V}, T_C = +25^\circ\text{C}$	-	-	-	250	μA	
		$V_{CE} = 400\text{V}, T_C = +125^\circ\text{C}$	-	1000	-	-	μA	
		$V_{CE} = 500\text{V}, T_C = +125^\circ\text{C}$	-	-	-	1000	μA	
Gate-Emitter Leakage Current	I_{GES}	$V_{GE} = \pm 20\text{V}, V_{CE} = 0$	-	100	-	100	nA	
Collector-Emitter On Voltage	$V_{CE(ON)}$	$I_C = 20\text{A}, V_{GE} = 10\text{V}$	-	2.5	-	2.5	V	
		$I_C = 35\text{A}, V_{GE} = 20\text{V}$	-	3.2	-	3.2	V	
Gate-Emitter Plateau Voltage	V_{GEP}	$I_C = 10\text{A}, V_{CE} = 10\text{V}$	-	6 (Typ)	-	6 (Typ)	V	
On-State Gate Charge	$Q_{G(ON)}$	$I_C = 10\text{A}, V_{CE} = 10\text{V}$	-	33 (Typ)	-	33 (Typ)	nC	
Turn-On Delay Time	$t_{D(ON)I}$	$I_C = 20\text{A}, V_{CE(CLIP)} = 300\text{V},$ $L = 25\mu\text{H}, T_J = +100^\circ\text{C},$ $V_{GE} = 10\text{V}, R_G = 25\Omega$	-	50	-	50	ns	
Rise Time	t_{RI}		-	50	-	50	ns	
Turn-Off Delay Time	$t_{D(OFF)I}$		-	400	-	400	ns	
Fall Time	t_{FI}		40E1D, 50E1D	680 (Typ)	1000	680 (Typ)	1000	ns
			40C1D, 50C1D	400 (Typ)	500	400 (Typ)	500	ns
Turn-Off Energy Loss per Cycle (Off Switching Dissipation = $W_{OFF} \times$ Frequency)	W_{OFF}	40E1D, 50E1D	1810 (Typ)				μJ	
		40C1D, 50C1D	1070 (Typ)				μJ	
Thermal Resistance Junction-to-Case	$R_{\theta JC}$		-	1.25	-	1.25	$^\circ\text{C/W}$	
Diode Forward Voltage	V_{EC}	$I_{EC} = 20\text{A}$	-	2	-	2	V	
Diode Reverse Recovery Time	t_{RR}	$I_{EC} = 20\text{A}, dI_{EC}/dt = 100\text{A}/\mu\text{s}$	-	100	-	100	ns	

Typical Performance Curves

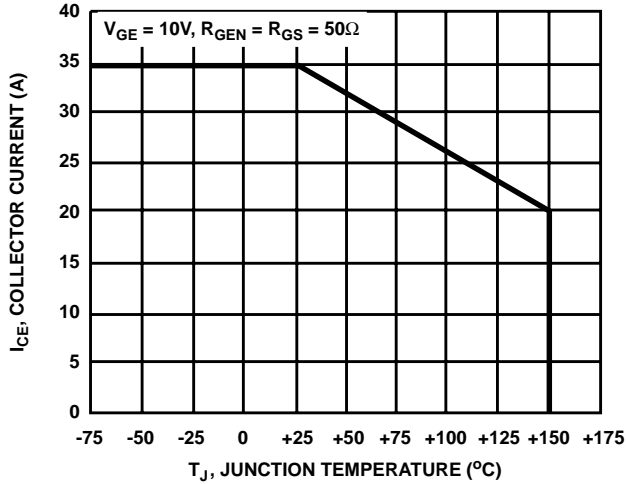

FIGURE 1. MAX. SWITCHING CURRENT LEVEL. $R_G = 50\Omega$, $V_{GE} = 0V$ ARE THE MIN. ALLOWABLE VALUES

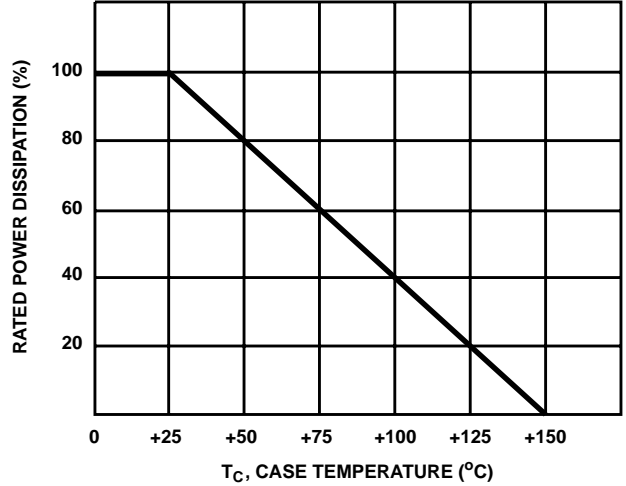

FIGURE 2. POWER DISSIPATION vs TEMPERATURE DERATING CURVE

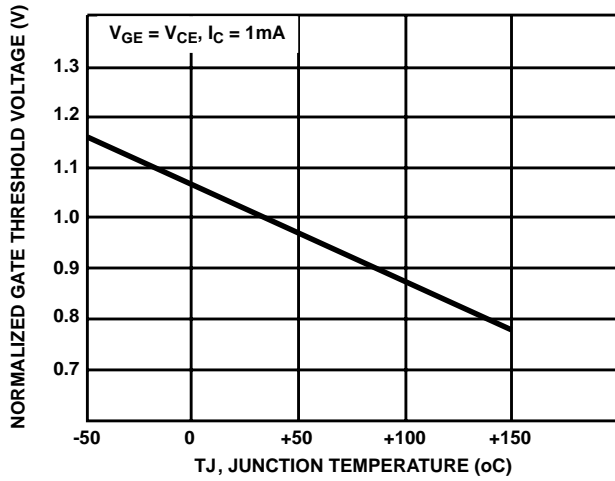

FIGURE 3. TYPICAL NORMALIZED GATE THRESHOLD VOLTAGE vs JUNCTION TEMPERATURE

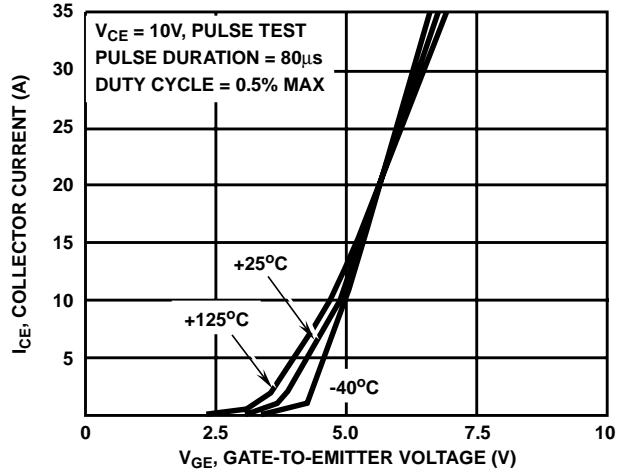

FIGURE 4. TYPICAL TRANSFER CHARACTERISTICS

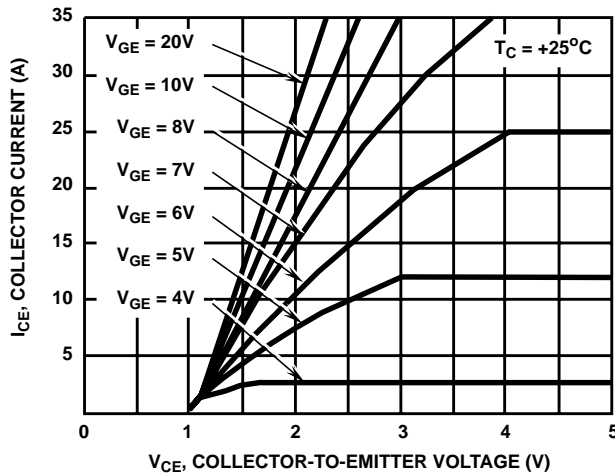

FIGURE 5. TYPICAL SATURATION CHARACTERISTICS

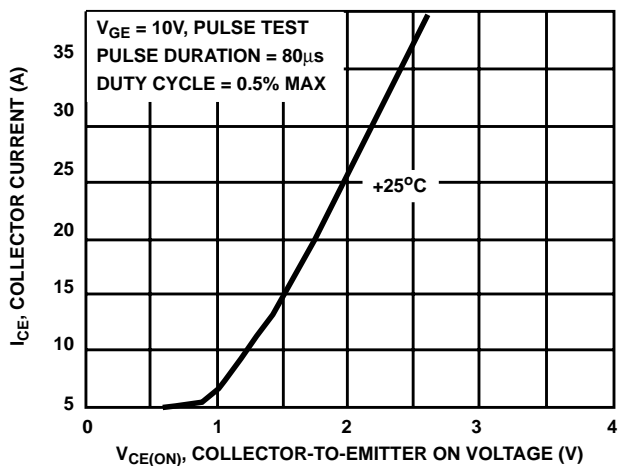

FIGURE 6. TYPICAL COLLECTOR-TO-EMITTER ON-VOLTAGE vs COLLECTOR CURRENT

Typical Performance Curves (Continued)

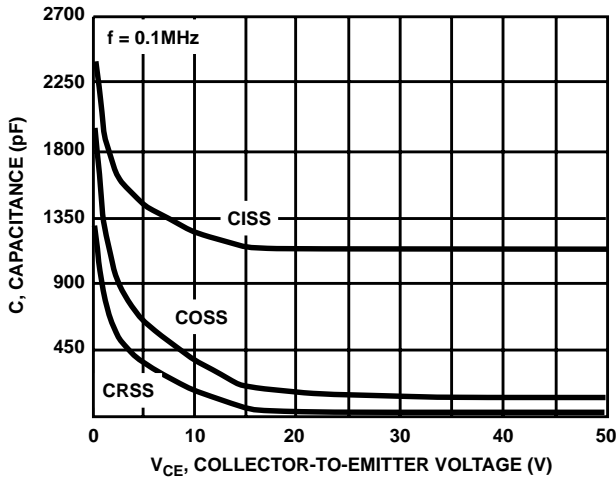

FIGURE 7. CAPACITANCE vs COLLECTOR-TO-EMITTER VOLTAGE

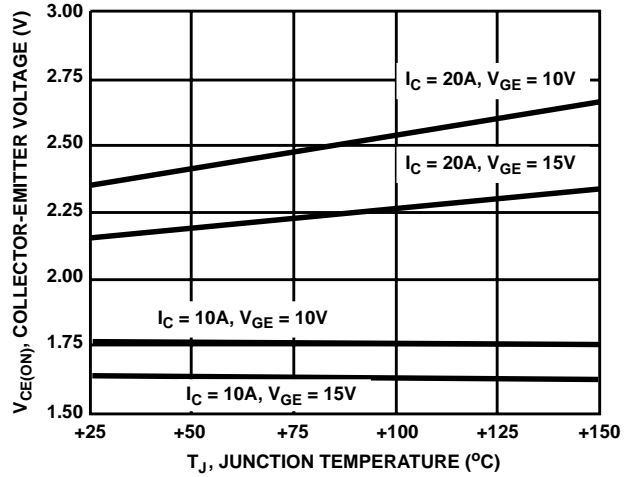

FIGURE 8. TYPICAL $V_{CE(ON)}$ vs TEMPERATURE

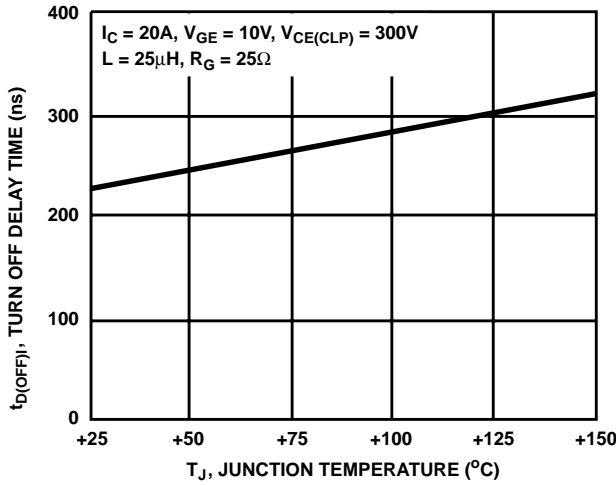

FIGURE 9. TYPICAL TURN-OFF DELAY TIME

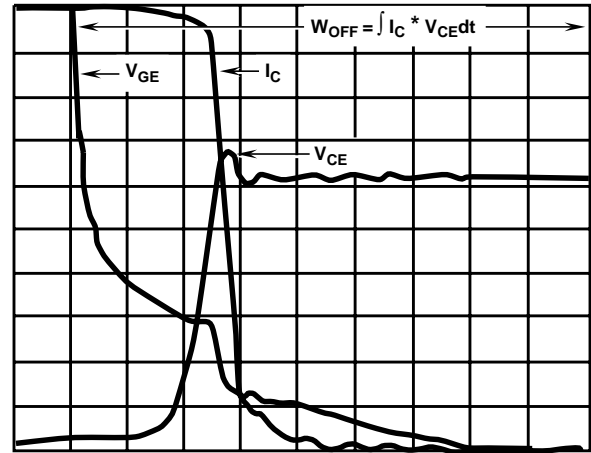

FIGURE 10. TYPICAL INDUCTIVE SWITCHING WAVEFORMS

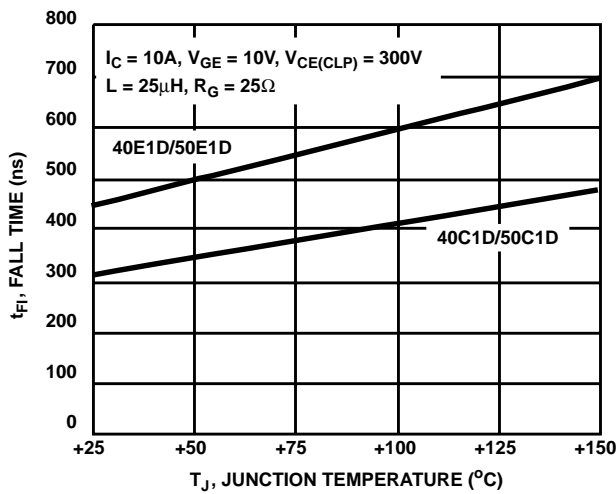

FIGURE 11. TYPICAL FALL TIME ($I_C = 10A$)

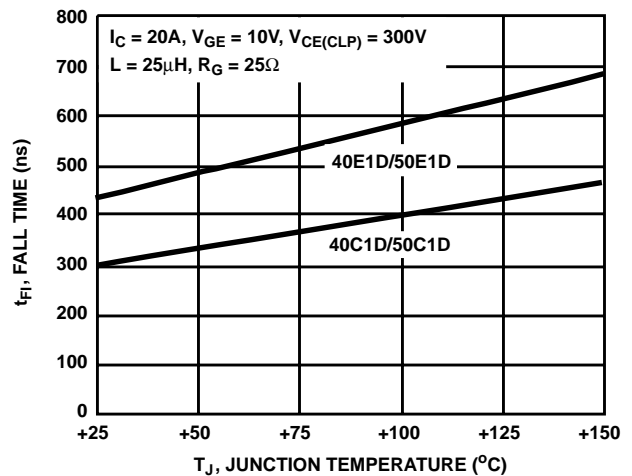

FIGURE 12. TYPICAL FALL TIME ($I_C = 20A$)

Typical Performance Curves (Continued)

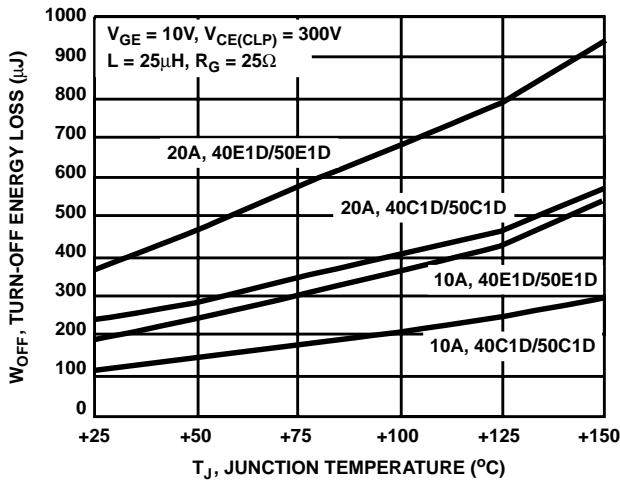
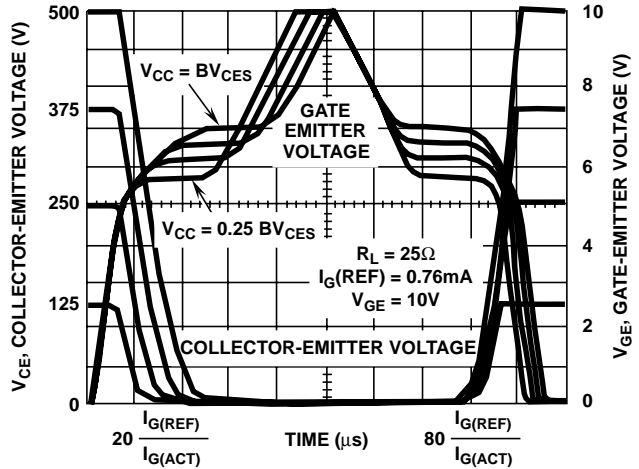

FIGURE 13. TYPICAL CLAMPED INDUCTIVE TURN-OFF SWITCHING LOSS/CYCLE



NOTE: For Turn-Off gate currents in excess of 3mA, V_{CE} Turn-Off is not accurately represented by this normalization.

FIGURE 14. NORMALIZED SWITCHING WAVEFORMS AT CONSTANT GATE CURRENT (REFER TO APPLICATION NOTES AN7254 AND AN7260)

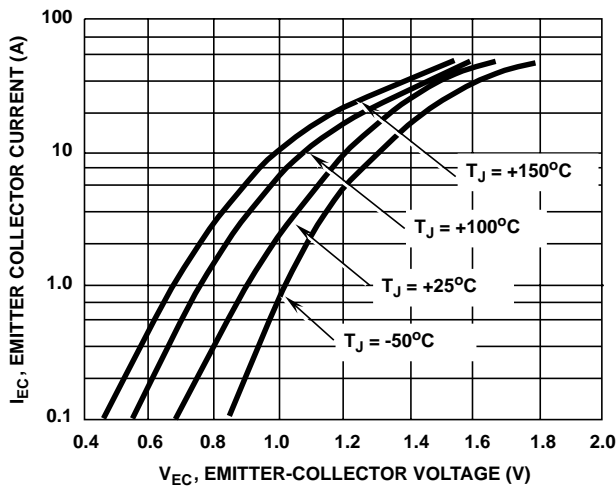

FIGURE 15. TYPICAL DIODE EMITTER-COLLECTOR VOLTAGE vs CURRENT

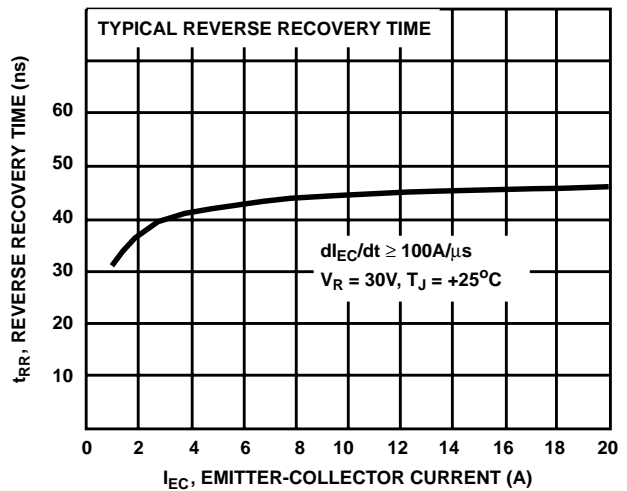

FIGURE 16. TYPICAL DIODE REVERSE RECOVERY TIME

Test Circuit

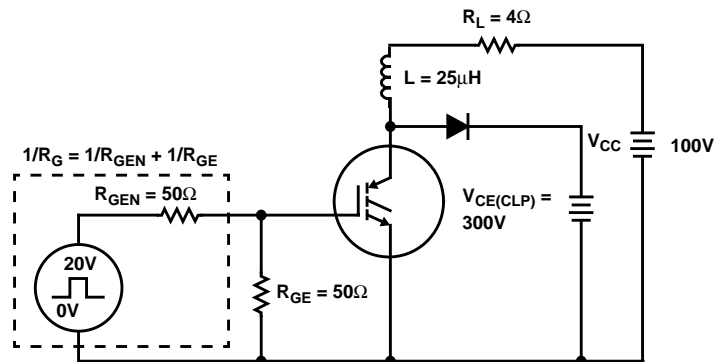

FIGURE 17. INDUCTIVE SWITCHING TEST CIRCUIT

All Intersil semiconductor products are manufactured, assembled and tested under **ISO9000** quality systems certification.

Intersil products are sold by description only. Intersil Corporation reserves the right to make changes in circuit design and/or specifications at any time without notice. Accordingly, the reader is cautioned to verify that data sheets are current before placing orders. Information furnished by Intersil is believed to be accurate and reliable. However, no responsibility is assumed by Intersil or its subsidiaries for its use; nor for any infringements of patents or other rights of third parties which may result from its use. No license is granted by implication or otherwise under any patent or patent rights of Intersil or its subsidiaries.

For information regarding Intersil Corporation and its products, see web site <http://www.intersil.com>

Sales Office Headquarters

NORTH AMERICA

Intersil Corporation
P. O. Box 883, Mail Stop 53-204
Melbourne, FL 32902
TEL: (407) 724-7000
FAX: (407) 724-7240

EUROPE

Intersil SA
Mercure Center
100, Rue de la Fusee
1130 Brussels, Belgium
TEL: (32) 2.724.2111
FAX: (32) 2.724.22.05

ASIA

Intersil (Taiwan) Ltd.
Taiwan Limited
7F-6, No. 101 Fu Hsing North Road
Taipei, Taiwan
Republic of China
TEL: (886) 2 2716 9310
FAX: (886) 2 2715 3029

This datasheet has been downloaded from:

www.DatasheetCatalog.com

Datasheets for electronic components.



LittleDiode supplies new, hard to find or obsolete electronic components and semiconductors all over the world.

With over two million different components listed you are sure to find the part you need.

Feel free to visit us today at our online store:

LittleDiode.com

Looking forward to providing you with the best possible service.