

Am29LV800T/Am29LV800B

8 Megabit (1,048,576 x 8-Bit/524,288 x 16-Bit)
CMOS 3.0 Volt-only, Sectored Flash Memory

DISTINCTIVE CHARACTERISTICS

■ Single power supply operation

- Extended voltage range: 2.7 to 3.6 volt read and write operations for battery-powered applications
- Standard voltage range: 3.0 to 3.6 volt read and write operations and for compatibility with high performance 3.3 volt microprocessors

■ High performance

- Extended voltage range: access times as fast as 100 ns
- Standard voltage range: access times as fast as 90 ns

■ Ultra low power consumption

- Automatic Sleep Mode: 200 nA typical
- Standby mode: 200 nA typical
- Read mode: 2 mA/MHz typical
- Program/erase mode: 20 mA typical

■ Flexible sector architecture

- One 16 Kbyte, two 8 Kbyte, one 32 Kbyte, and fifteen 64 Kbyte sectors (byte mode)
- One 8 Kword, two 4 Kword, one 16 Kword, and fifteen 32 Kword sectors (word mode)
- Supports control code and data storage on a single device
- Sector Protection features:
 - A hardware method of locking a sector to prevent any program or erase operations within that sector
 - Temporary Sector Unprotect feature allows code changes in previously locked sectors

■ Top or bottom boot block configurations available

■ Embedded Algorithms

- Embedded Erase algorithms automatically preprogram and erase the entire chip or any combination of designated sectors
- Embedded Program algorithms automatically write and verify bytes or words at specified addresses

■ Minimum 100,000 write cycle guarantee per sector

■ Package options

- 48-pin TSOP
- 44-pin SO

■ Compatibility with JEDEC standards

- Pinout and software compatible with single-power supply Flash
- Superior inadvertent write protection

■ Data Polling and toggle bits

- Provides a software method of detecting program or erase operation completion

■ Ready/Busy pin (RY/BY)

- Provides a hardware method of detecting program or erase cycle completion

■ Erase suspend/resume commands

- Suspends the erase operation to read data from or program data to another sector, then resumes the erase operation

■ Hardware reset pin ($\overline{\text{RESET}}$)

- Hardware method to reset the device to the read mode

GENERAL DESCRIPTION

The Am29LV800 is an 8 Mbit, 3.0 Volt-only Flash memory organized as 1 Mbyte of 8 bits each or 512K words of 16 bits each. For flexible erase and program capability, the 8 Mbits of data is divided into 19 sectors of one 16 Kbyte, two 8 Kbyte, one 32 Kbyte, and fifteen 64 Kbytes. The x8 data appears on DQ0–DQ7; the x16 data appears on DQ0–DQ15. The Am29LV800 is offered in 44-pin SO and 48-pin TSOP packages. This device is designed to be programmed in-system with the standard system 3.0 Volt V_{CC} supply. The device can also be reprogrammed in standard EPROM programmers.

The Am29LV800 provides two levels of performance. The first level offers access times as fast as 100 ns with a V_{CC} range as low as 2.7 volts, which is optimal for battery powered applications. The second level offers a 90 ns access time, optimizing performance in systems where the power supply is in the regulated range of 3.0 to 3.6 volts. To eliminate bus contention, the device has separate chip enable (\overline{CE}), write enable (\overline{WE}), and output enable (\overline{OE}) controls.

The Am29LV800 is entirely command set compatible with the JEDEC single-power-supply Flash standard. Commands are written to the command register using standard microprocessor write timings. Register contents serve as input to an internal state-machine which controls the erase and programming circuitry. Write cycles also internally latch addresses and data needed for the programming and erase operations. Reading data out of the device is similar to reading from other Flash or EPROM devices.

The Am29LV800 is programmed by executing the program command sequence. This will invoke the Embedded Program Algorithm which is an internal algorithm that automatically times the program pulse widths and verifies proper cell margin. Erase is accomplished by executing the erase command sequence. This will invoke the Embedded Erase Algorithm which is an internal algorithm that automatically pre-programs the array if it is not already programmed before executing the erase operation. During erase, the device automatically times the erase pulse widths and verifies proper cell margin.

This device also features a sector erase architecture. This allows for sectors of memory to be erased and reprogrammed without affecting the data contents of

other sectors. A sector is typically erased and verified within 1.0 second. The Am29LV800 is fully erased when shipped from the factory.

The Am29LV800 device also features hardware sector protection. This feature will disable both program and erase operations in any combination of nineteen sectors of memory.

AMD has implemented an Erase Suspend feature that enables the user to put erase on hold for any period of time to read data from or program data to a sector that was not being erased. Thus, true background erase can be achieved.

The device features single 3.0 Volt power supply operation for both read and write functions. Internally generated and regulated voltages are provided for the program and erase operations. A low V_{CC} detector automatically inhibits write operations during power transitions. The end of program or erase is detected by the RY/ \overline{BY} pin. \overline{Data} Polling of DQ7, or by the Toggle Bit (DQ6). Once the end of a program or erase cycle has been completed, the device automatically resets to the read mode.

The Am29LV800 also has a hardware \overline{RESET} pin. When this pin is driven low, execution of any Embedded Program Algorithm or Embedded Erase Algorithm will be terminated. The internal state machine will then be reset into the read mode. The \overline{RESET} pin may be tied to the system reset circuitry. Therefore, if a system reset occurs during the Embedded Program Algorithm or Embedded Erase Algorithm, the device will be automatically reset to the read mode and will have erroneous data stored in the address locations being operated on. These locations will need rewriting after the Reset. Resetting the device will enable the system's microprocessor to read the boot-up firmware from the Flash memory.

AMD's Flash technology combines years of Flash memory manufacturing experience to produce the highest levels of quality, reliability and cost effectiveness. The Am29LV800 memory electrically erases all bits within a sector simultaneously via Fowler-Nordheim tunneling. The bytes/words are programmed one byte/word at a time using the EPROM programming mechanism of hot electron injection.

Flexible Sector Architecture

- One 8 Kword, two 4 Kwords, one 16 Kword, and fifteen 32 Kwords sectors in word mode
- One 16 Kbyte, two 8 Kbytes, one 32 Kbyte, and fifteen 64 Kbyte sectors in byte mode

- Individual-sector or multiple-sector erase capability
- Sector protection is user definable

		(x8) Address Range	(x16) Address Range
SA18	16 Kbytes 8 Kwords	FC000h-FFFFFh	7E000h-7FFFFh
SA17	8 Kbytes 4 Kwords	FA000h-FBFFFh	7D000h-7DFFFh
SA16	8 Kbytes 4 Kwords	F8000h-F9FFFh	7C000h-7CFFFh
SA15	32 Kbytes 16 Kwords	F0000h-F7FFFh	78000h-7BFFFh
SA14	64 Kbytes 32 Kwords	E0000h-EFFFFh	70000h-77FFFh
SA13	64 Kbytes 32 Kwords	D0000h-DFFFFh	68000h-6FFFFh
SA12	64 Kbytes 32 Kwords	C0000h-CFFFFh	60000h-67FFFh
SA11	64 Kbytes 32 Kwords	B0000h-BFFFFh	58000h-5FFFFh
SA10	64 Kbytes 32 Kwords	A0000h-AFFFFh	50000h-57FFFh
SA9	64 Kbytes 32 Kwords	90000h-9FFFFh	48000h-4FFFFh
SA8	64 Kbytes 32 Kwords	80000h-8FFFFh	40000h-47FFFh
SA7	64 Kbytes 32 Kwords	70000h-7FFFFh	38000h-3FFFFh
SA6	64 Kbytes 32 Kwords	60000h-6FFFFh	30000h-37FFFh
SA5	64 Kbytes 32 Kwords	50000h-5FFFFh	28000h-2FFFFh
SA4	64 Kbytes 32 Kwords	40000h-4FFFFh	20000h-27FFFh
SA3	64 Kbytes 32 Kwords	30000h-3FFFFh	18000h-1FFFFh
SA2	64 Kbytes 32 Kwords	20000h-2FFFFh	10000h-17FFFh
SA1	64 Kbytes 32 Kwords	10000h-1FFFFh	08000h-0FFFFh
SA0	64 Kbytes 32 Kwords	00000h-0FFFFh	00000h-07FFFh

20478D-1

Am29LV800T Sector Architecture

Notes:

The address range is A18:A-1 if in byte mode ($\overline{\text{BYTE}} = V_{IL}$).

The address range is A18:A0 if in word mode ($\overline{\text{BYTE}} = V_{IH}$).

		(x8) Address Range	(x16) Address Range
SA18	64 Kbytes 32 Kwords	F0000h-FFFFFh	78000h-7FFFFh
SA17	64 Kbytes 32 Kwords	E0000h-EFFFFh	70000h-77FFFh
SA16	64 Kbytes 32 Kwords	D0000h-DFFFFh	68000h-6FFFFh
SA15	64 Kbytes 32 Kwords	C0000h-CFFFFh	60000h-67FFFh
SA14	64 Kbytes 32 Kwords	B0000h-BFFFFh	58000h-5FFFFh
SA13	64 Kbytes 32 Kwords	A0000h-AFFFFh	50000h-57FFFh
SA12	64 Kbytes 32 Kwords	90000h-9FFFFh	48000h-4FFFFh
SA11	64 Kbytes 32 Kwords	80000h-8FFFFh	40000h-47FFFh
SA10	64 Kbytes 32 Kwords	70000h-7FFFFh	38000h-3FFFFh
SA9	64 Kbytes 32 Kwords	60000h-6FFFFh	30000h-37FFFh
SA8	64 Kbytes 32 Kwords	50000h-5FFFFh	28000h-2FFFFh
SA7	64 Kbytes 32 Kwords	40000h-4FFFFh	20000h-27FFFh
SA6	64 Kbytes 32 Kwords	30000h-3FFFFh	18000h-1FFFFh
SA5	64 Kbytes 32 Kwords	20000h-2FFFFh	10000h-17FFFh
SA4	64 Kbytes 32 Kwords	10000h-1FFFFh	08000h-0FFFFh
SA3	32 Kbytes 16 Kwords	08000h-0FFFFh	04000h-07FFFh
SA2	8 Kbytes 4 Kwords	06000h-07FFFh	03000h-03FFFh
SA1	8 Kbytes 4 Kwords	04000h-05FFFh	02000h-02FFFh
SA0	16 Kbytes 8 Kwords	00000h-03FFFh	00000h-01FFFh

20478D-2

Am29LV800B Sector Architecture

PRODUCT SELECTOR GUIDE

Family Part Number	Am29LV800T/Am29LV800B			
Ordering Part Number: $V_{CC} = 3.0-3.6\text{ V}$	-90R			
$V_{CC} = 2.7-3.6\text{ V}$		-100	-120	-150
Max access time (ns)	90	100	120	150
\overline{CE} access time (ns)	90	100	120	150
\overline{OE} access time (ns)	40	40	50	55

BLOCK DIAGRAM

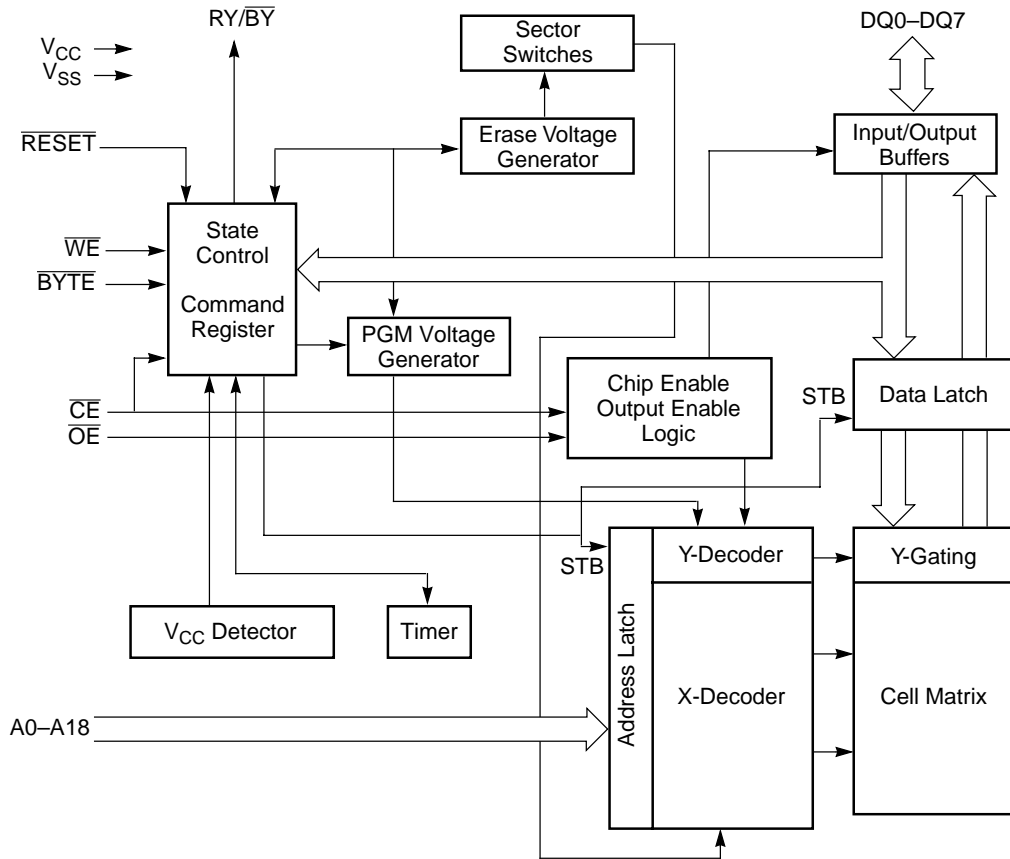

20478D-3

CONNECTION DIAGRAMS

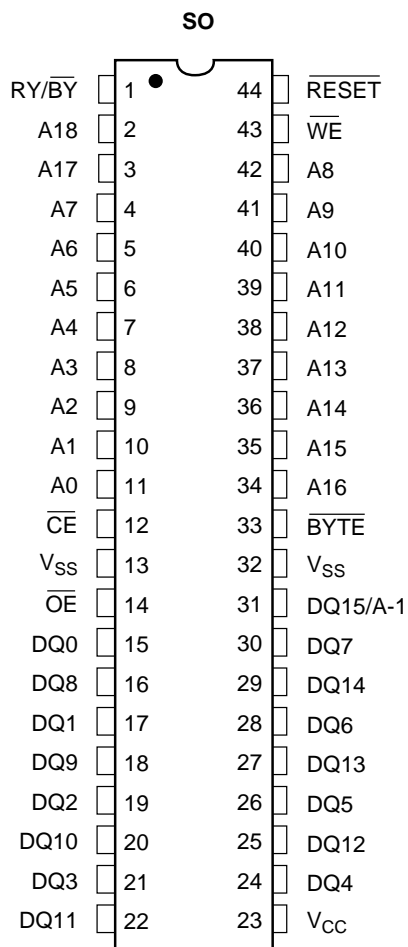

20478D-4

CONNECTION DIAGRAMS



Standard TSOP

20478D-5

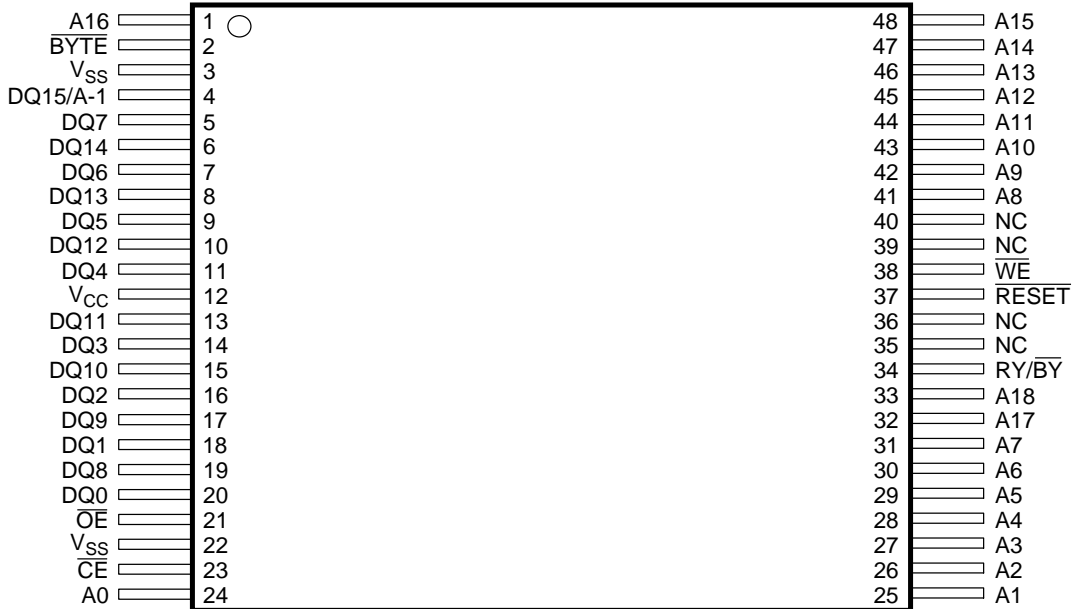

Reverse TSOP

20478D-6

PIN CONFIGURATION

A0–A18	= 19 addresses
DQ0–DQ14	= 15 data inputs/outputs
DQ15/A-1	= DQ15 data input/output (word mode), A-1 (LSB address input, byte mode)
$\overline{\text{BYTE}}$	= Selects 8-bit or 16-bit mode
$\overline{\text{CE}}$	= Chip enable
$\overline{\text{OE}}$	= Output enable
$\overline{\text{WE}}$	= Write enable
$\overline{\text{RESET}}$	= Hardware reset pin, active low
$\text{RY}/\overline{\text{BY}}$	= Ready/Busy output
V_{CC}	= Standard voltage range (3.0 to 3.6 V) for -90R Extended voltage range (2.7 to 3.6 V) for -100, -120, -150
V_{SS}	= Device ground
NC	= Pin not connected internally

LOGIC SYMBOL

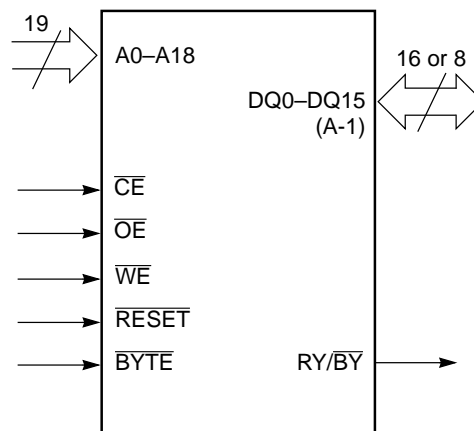

20478D-7

ORDERING INFORMATION

Standard Products

AMD standard products are available in several packages and operating ranges. The order number (Valid Combination) is formed by a combination of the elements below.

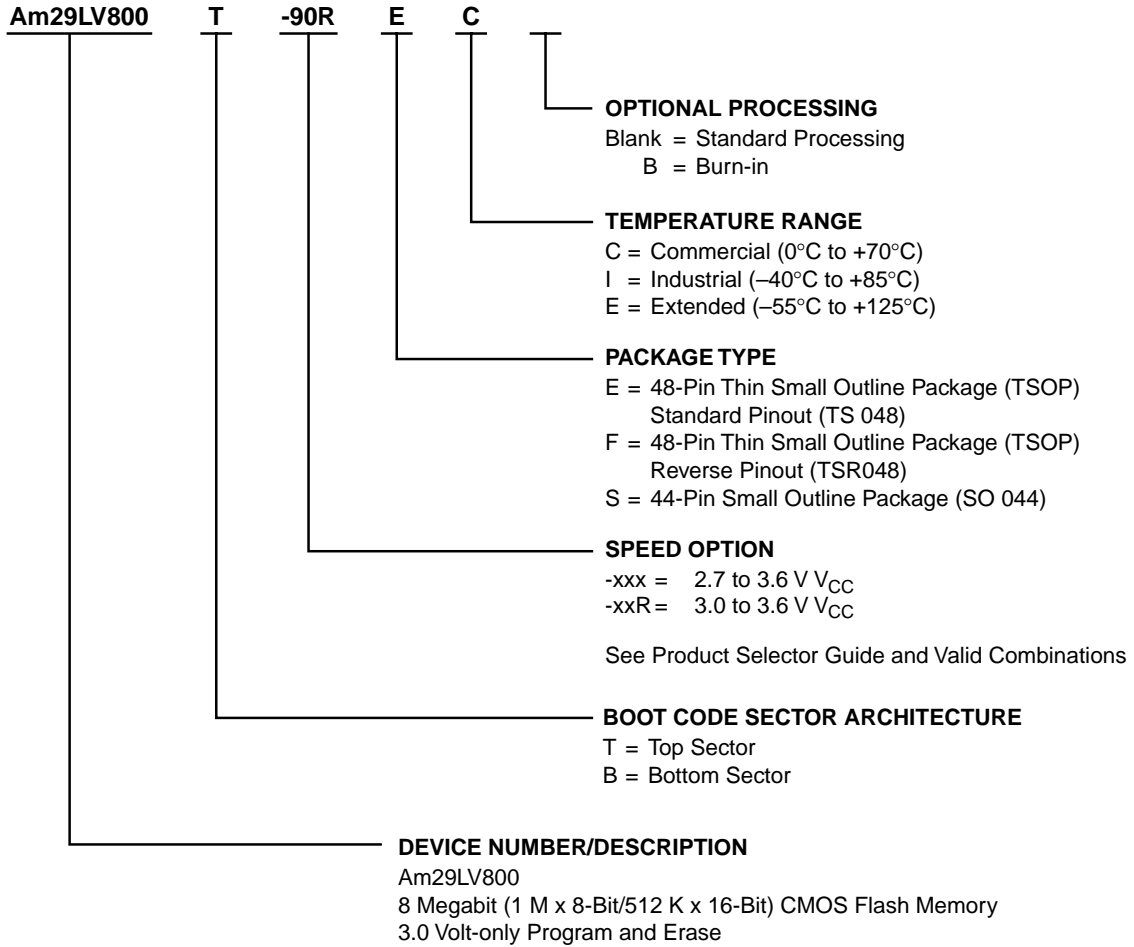

Valid Combinations	
Am29LV800T-90R, Am29LV800B-90R $V_{CC} = 3.0-3.6 V$	EC, EI, FC, FI, SC, SI

Valid Combinations	
Am29LV800T-100, Am29LV800B-100	SC, SI, SE, SEB, EC, EI, EE, EEB, FC, FI, FE, FEB
Am29LV800T-120, Am29LV800B-120	
Am29LV800T-150, Am29LV800B-150	

Table 1. Am29LV800 User Bus Operations ($\overline{\text{BYTE}} = V_{IH}$)

Operation	$\overline{\text{CE}}$	$\overline{\text{OE}}$	$\overline{\text{WE}}$	A0	A1	A6	A9	DQ0–DQ15	$\overline{\text{RESET}}$
Autoselect, Manufacturer Code (Note 1)	L	L	H	L	L	L	V_{ID}	Code	H
Autoselect Device Code (Note 1)	L	L	H	H	L	L	V_{ID}	Code	H
Read	L	L	H	A0	A1	A6	A9	D_{OUT}	H
Standby	H	X	X	X	X	X	X	HIGH Z	H
Output Disable	L	H	H	X	X	X	X	HIGH Z	H
Write	L	H	L	A0	A1	A6	A9	D_{IN} (Note 2)	H
Enable Sector Protect (Note 3)	L	V_{ID}	Pulse/H	L	H	L	V_{ID}	Code	H
Verify Sector Protect (Note 4)	L	L	H	L	H	L	V_{ID}	Code	H
Temporary Sector Unprotect	X	X	X	X	X	X	X	X	V_{ID}
Reset	X	X	X	X	X	X	X	HIGH Z	L

Table 2. Am29LV800 User Bus Operations ($\overline{\text{BYTE}} = V_{IL}$)

Operation	$\overline{\text{CE}}$	$\overline{\text{OE}}$	$\overline{\text{WE}}$	A0	A1	A6	A9	DQ0–DQ7	DQ8–DQ15	$\overline{\text{RESET}}$
Autoselect, Manufacturer Code (Note 1)	L	L	H	L	L	L	V_{ID}	Code	HIGH Z	H
Autoselect, Device Code (Note 1)	L	L	H	H	L	L	V_{ID}	Code	HIGH Z	H
Read	L	L	H	A0	A1	A6	A9	D_{OUT}	HIGH Z	H
Standby	H	X	X	X	X	X	X	HIGH Z	HIGH Z	H
Output Disable	L	H	H	X	X	X	X	HIGH Z	HIGH Z	H
Write	L	H	L	A0	A1	A6	A9	D_{IN} (Note 2)	HIGH Z	H
Enable Sector Protect (Note 3)	L	V_{ID}	Pulse/H	L	H	L	V_{ID}	Code	HIGH Z	H
Verify Sector Protect (Note 4)	L	L	H	L	H	L	V_{ID}	Code	HIGH Z	H
Temporary Sector Unprotect	X	X	X	X	X	X	X	X	HIGH Z	V_{ID}
Reset	X	X	X	X	X	X	X	HIGH Z	HIGH Z	L

Legend:

L = Logic 0, H = Logic 1, $V_{ID} = 12.0 \pm 0.5$ Volts, X = Don't care. See DC Characteristics (Table 12 and 13) for voltage levels.

Notes:

1. Manufacturer and device codes may also be accessed via a command register write sequence. Refer to Table 6.
2. Refer to Table 6 for valid Data in (D_{IN}) during a write operation.
3. Set $V_{CC} = 3.0$ Volts $\pm 10\%$.
4. Refer to Sector Protection section.

USER BUS OPERATIONS

Read Mode

The Am29LV800 has three control functions which must be satisfied in order to obtain data at the outputs:

- \overline{CE} is the power control and should be used for device selection ($\overline{CE} = V_{IL}$)
- \overline{OE} is the output control and should be used to gate data to the output pins if the device is selected ($\overline{OE} = V_{IL}$)
- \overline{WE} remains at V_{IH}

Address access time (t_{ACC}) is equal to the delay from stable addresses to valid output data. The chip enable access time (t_{CE}) is the delay from stable addresses and stable \overline{CE} to valid data at the output pins. The output enable access time (t_{OE}) is the delay from the falling edge of \overline{OE} to valid data at the output pins (assuming the addresses have been stable at least $t_{ACC} - t_{OE}$ time).

Standby Mode

The Am29LV800 is designed to accommodate two modes for low standby power consumption. Both modes are enabled by applying the voltages specified below to the \overline{CE} and \overline{RESET} pins. These modes are available for either TTL/NMOS or CMOS logic level designs. The first mode, I_{CC3} for TTL/NMOS compatible I/Os (current consumption <1 mA max.), is enabled by applying a TTL logic level '1' (V_{IH}) to the \overline{CE} control pin with $\overline{RESET} = V_{IH}$. I_{CC3} for CMOS compatible I/Os (current consumption <5 μ A max.), is enabled when a CMOS logic level '1' ($V_{CC} \pm 0.3$ V) is applied to the \overline{CE} control pin with $\overline{RESET} = V_{CC} \pm 0.3$ V. While in the I_{CC3}

standby mode, the data I/O pins remain in the high impedance state independent of the voltage level applied to the \overline{OE} input. See the DC Characteristics section for more details on Standby Modes.

Deselecting \overline{CE} ($\overline{CE} = V_{IH}$ or $V_{CC} \pm 0.3$ V, with $\overline{RESET} = V_{IH}$ or $V_{CC} \pm 0.3$ V), will put the device into the I_{CC3} standby mode. If the device is deselected during an Embedded Algorithm™ operation, it will continue to draw active power (I_{CC2}), prior to entering the standby mode, until the operation is complete. Subsequent reselection of the device for active operations ($\overline{CE} = V_{IL}$) will commence pursuant to the AC timing specifications.

Automatic Sleep Mode

Advanced power management features such as the automatic sleep mode minimize Flash device energy consumption. This is extremely important in battery-powered applications. The Am29LV800 automatically enables the low-power, automatic sleep mode when addresses remain stable for 200 ns. Automatic sleep mode is independent of the \overline{CE} , \overline{WE} , and \overline{OE} control signals. Typical sleep mode current draw is 200 nA (for CMOS-compatible operation). Standard address access timings provide new data when addresses are changed. While in sleep mode, output data is latched and always available to the system.

Output Disable

If the \overline{OE} input is at a logic high level (V_{IH}), output from the device is disabled. This will cause the output pins to be in a high impedance state.

Autoselect

The Autoselect mode allows the reading out of a binary code from the device and will identify its manufacturer and type. The intent is to allow programming equipment to automatically match the device to be programmed with its corresponding programming algorithm. The Autoselect command may also be used to check the status of write-protected sectors (see Table 3). This mode is functional over the entire temperature range of the device.

To activate this mode, the programming equipment must force V_{ID} (11.5–12.5 volts) on address pin A9. Two identifier bytes may then be sequenced from the device outputs by toggling address A0 from V_{IL} to V_{IH} . All addresses are don't cares except A0, A1, and A6 (see Table 3).

The manufacturer and device codes may also be read via the command register, for instances when the Am29LV800 is erased or programmed in a system

without access to high voltage on the A9 pin. The command sequence is illustrated in Table 6.

Byte 0 ($A0 = V_{IL}$) represents the manufacturer's code and byte 1 ($A0 = V_{IH}$) the device identifier code. These two bytes are given for the Am29LV800 in Table 3. All identifiers for manufacturer and device exhibit odd parity with DQ7 defined as the parity bit. In order to read the proper device codes when executing Autoselect, A1 must be V_{IL} (see Table 3). For device identification in word mode ($\overline{BYTE} = V_{IH}$), DQ9 and DQ13 are equal to '1' and DQ8, DQ10–12, DQ14, and DQ15 are equal to '0'.

If $\overline{BYTE} = V_{IH}$ (for word mode), the device code is 22DAh (for top boot block) or 225Bh (for bottom boot block). If $\overline{BYTE} = V_{IL}$ (for byte mode), the device code is DAh (for top boot block) or 5Bh (for bottom boot block).

In order to determine which sectors are write protected, A1 must be at V_{IH} while running through the sector addresses. If the selected sector is protected, the device outputs a '1' on DQ0.

Table 3. Autoselect/Sector Protection Codes

Type	Mode	A12–A18	A6	A1	A0	Code (HEX)	DQ8–DQ15	DQ 7	DQ 6	DQ 5	DQ 4	DQ 3	DQ 2	DQ 1	DQ 0
Manufacturer Code: AMD		X	L	L	L	01h	High-Z	0	0	0	0	0	0	0	1
29LV800 Device (Top Boot Block)	Word	X	L	L	H	22DAh	DQ9 = 1, DQ13 = 1, Others = 0	1	1	0	1	1	0	1	0
	Byte	X				DAh									
29LV800 Device (Bottom Boot Block)	Word	X	L	L	H	225Bh	DQ9 = 1, DQ13 = 1, Others = 0	0	1	0	1	1	0	1	1
	Byte	X				5Bh									
Sector Protection		Set Sector Addresses	L	H	L	01h*	X	0	0	0	0	0	0	0	1

X = Don't care.

* Outputs 01h at protected sector addresses.

Table 4. Sector Address Tables (Am29LV800T)

	A18	A17	A16	A15	A14	A13	A12	Sector Size	(x8) Address Range	(x16) Address Range
SA0	0	0	0	0	X	X	X	64 Kbytes 32 Kwords	00000h-0FFFFh	00000h-07FFFh
SA1	0	0	0	1	X	X	X	64 Kbytes 32 Kwords	10000h-1FFFFh	08000h-0FFFFh
SA2	0	0	1	0	X	X	X	64 Kbytes 32 Kwords	20000h-2FFFFh	10000h-17FFFh
SA3	0	0	1	1	X	X	X	64 Kbytes 32 Kwords	30000h-3FFFFh	18000h-1FFFFh
SA4	0	1	0	0	X	X	X	64 Kbytes 32 Kwords	40000h-4FFFFh	20000h-27FFFh
SA5	0	1	0	1	X	X	X	64 Kbytes 32 Kwords	50000h-5FFFFh	28000h-2FFFFh
SA6	0	1	1	0	X	X	X	64 Kbytes 32 Kwords	60000h-6FFFFh	30000h-37FFFh
SA7	0	1	1	1	X	X	X	64 Kbytes 32 Kwords	70000h-7FFFFh	38000h-3FFFFh
SA8	1	0	0	0	X	X	X	64 Kbytes 32 Kwords	80000h-8FFFFh	40000h-47FFFh
SA9	1	0	0	1	X	X	X	64 Kbytes 32 Kwords	90000h-9FFFFh	48000h-4FFFFh
SA10	1	0	1	0	X	X	X	64 Kbytes 32 Kwords	A0000h-AFFFFh	50000h-57FFFh
SA11	1	0	1	1	X	X	X	64 Kbytes 32 Kwords	B0000h-BFFFFh	58000h-5FFFFh
SA12	1	1	0	0	X	X	X	64 Kbytes 32 Kwords	C0000h-CFFFFh	60000h-67FFFh
SA13	1	1	0	1	X	X	X	64 Kbytes 32 Kwords	D0000h-DFFFFh	68000h-6FFFFh
SA14	1	1	1	0	X	X	X	64 Kbytes 32 Kwords	E0000h-EFFFFh	70000h-77FFFh
SA15	1	1	1	1	0	X	X	32 Kbytes 16 Kwords	F0000h-F7FFFh	78000h-7BFFFh
SA16	1	1	1	1	1	0	0	8 Kbytes 4 Kwords	F8000h-F9FFFh	7C000h-7CFFFh
SA17	1	1	1	1	1	0	1	8 Kbytes 4 Kwords	FA000h-FBFFFh	7D000h-7DFFFh
SA18	1	1	1	1	1	1	X	16 Kbyte 8 Kwords	FC000h-FFFFFh	7E000h-7FFFFh

Note: The address range is A18:A-1 if in byte mode ($\overline{BYTE} = V_{IL}$). The address range is A18:A0 if in word mode ($\overline{BYTE} = V_{IH}$).

Table 5. Sector Address Tables (Am29LV800B)

	A18	A17	A16	A15	A14	A13	A12	Sector Size	(x8) Address Range	(x16) Address Range
SA0	0	0	0	0	0	0	X	16 Kbytes 8 Kwords	00000h–03FFFh	00000h-01FFFh
SA1	0	0	0	0	0	1	0	8 Kbytes 4 Kwords	04000h–05FFFh	02000h-02FFFh
SA2	0	0	0	0	0	1	1	8 Kbytes 4 Kwords	06000h–07FFFh	03000h-03FFFh
SA3	0	0	0	0	1	X	X	32 Kbytes 16 Kwords	08000h–0FFFFh	04000h-07FFFh
SA4	0	0	0	1	X	X	X	64 Kbytes 32 Kwords	10000h–1FFFFh	08000h-0FFFFh
SA5	0	0	1	0	X	X	X	64 Kbytes 32 Kwords	20000h–2FFFFh	10000h-17FFFh
SA6	0	0	1	1	X	X	X	64 Kbytes 32 Kwords	30000h–3FFFFh	18000h-1FFFFh
SA7	0	1	0	0	X	X	X	64 Kbytes 32 Kwords	40000h–4FFFFh	20000h-27FFFh
SA8	0	1	0	1	X	X	X	64 Kbytes 32 Kwords	50000h–5FFFFh	28000h-2FFFFh
SA9	0	1	1	0	X	X	X	64 Kbytes 32 Kwords	60000h–6FFFFh	30000h-37FFFh
SA10	0	1	1	1	X	X	X	64 Kbytes 32 Kwords	70000h–7FFFFh	38000h-3FFFFh
SA11	1	0	0	0	X	X	X	64 Kbytes 32 Kwords	80000h–8FFFFh	40000h-47FFFh
SA12	1	0	0	1	X	X	X	64 Kbytes 32 Kwords	90000h–9FFFFh	48000h-4FFFF
SA13	1	0	1	0	X	X	X	64 Kbytes 32 Kwords	A0000h–AFFFFh	50000h-57FFFh
SA14	1	0	1	1	X	X	X	64 Kbytes 32 Kwords	B0000h–BFFFFh	58000h-5FFFFh
SA15	1	1	0	0	X	X	X	64 Kbytes 32 Kwords	C0000h–CFFFFh	60000h-67FFFh
SA16	1	1	0	1	X	X	X	64 Kbytes 32 Kwords	D0000h–DFFFFh	68000h-6FFFFh
SA17	1	1	1	0	X	X	X	64 Kbytes 32 Kwords	E0000h–EFFFFh	70000h-77FFFh
SA18	1	1	1	1	X	X	X	64 Kbytes 32 Kwords	F0000h–FFFFFh	78000h-7FFFFh

Note: The address range is A18:A-1 if in byte mode ($\overline{\text{BYTE}} = V_{IL}$). The address range is A18:A0 if in word mode ($\overline{\text{BYTE}} = V_{IH}$).

Write

Device erasure and programming are accomplished via the command register. The command register is written by bringing \overline{WE} to V_{IL} , while \overline{CE} is at V_{IL} and \overline{OE} is at V_{IH} . Addresses are latched on the falling edge of \overline{CE} or \overline{WE} , whichever occurs later, while data is latched on the rising edge of the \overline{CE} or \overline{WE} pulse, whichever occurs first. Standard microprocessor write timings are used.

Refer to AC Write Characteristics and the Erase/Programming Waveforms for specific timing parameters.

Sector Protect

Sectors of the Am29LV800 may be hardware protected at the user's factory with external programming equipment. The protection circuitry will disable both program and erase functions for the protected sectors, making the protected sectors read-only. Requests to program or erase a protected sector will be ignored by the device. If the user attempts to write to a protected sector, \overline{DATA} Polling will be activated for about 1 μ s; the device will then return to read mode, with data from the protected sector unchanged. If the

user attempts to erase a protected sector, Toggle Bit will be activated for about 50 μ s; the device will then return to read mode, without having erased the protected sector.

It is possible to determine if a sector is protected in the system by writing an Autoselect command. Performing a read operation at the address location XX02h, where the higher order address A18–A12 represents the sector address, will produce a logical '1' at DQ0 for a protected sector.

Temporary Sector Unprotect

The sectors of the Am29LV800 may be temporarily unprotected by raising the \overline{RESET} pin to 12.0 Volts (V_{ID}). During this mode, formerly protected sectors can be programmed or erased with standard command sequences by selecting the appropriate byte or sector addresses. Once the \overline{RESET} pin goes to TTL level (V_{IH}), all the previously protected sectors will be protected again.

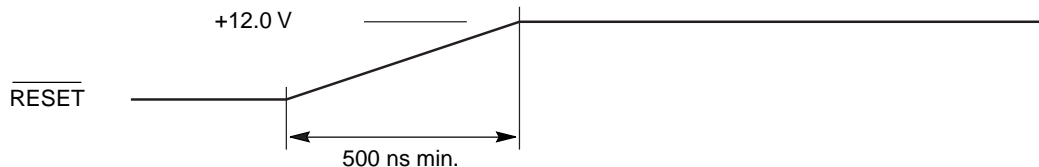

Figure 1. Temporary Sector Unprotect Timing Diagram

20478D-8

Command Definitions

Device operations are selected by writing specific address and data sequences into the command register. **Writing incorrect address and data values or writing them in the improper sequence will reset the device to the read mode.** Table 6 defines the valid register command sequences. Note that the Erase Suspend (B0h) and Erase Resume (30h) commands are valid only while the Sector Erase operation is in progress.

Read/Reset Command

The device will automatically power up in the read/reset state. In this case, a command sequence is not required to read data. Standard microprocessor cycles will retrieve array data. This default value ensures that no spurious alteration of the memory content occurs during the power transition. Refer to the AC Characteristics section for the specific timing parameters.

The read or reset operation is initiated by writing the read/reset command sequence into the command register. Microprocessor read cycles retrieve array data from the memory. The device remains enabled for reads until the command register contents are altered.

Autoselect Command

Flash memories are intended for use in applications where the local CPU alters memory contents. As such, manufacturer and device codes must be accessible while the device resides in the target system. The Am29LV800 contains an autoselect command operation that provides device information and sector protection status to the system. The operation is initiated by writing the autoselect command sequence into the command register. Following the command write, a read cycle from address XX00h retrieves the manufacturer code of 01h. A read cycle from address XX01h returns the device code DAh/5Bh for x8 configuration or 22DAh/225Bh for x16 configuration (see Table 3). All manufacturer and device codes will exhibit odd parity with the MSB of the lower byte (DQ7) defined as the parity bit. Scanning the sector addresses (A12, A13, A14, A15, A16, A17, and A18) while (A6, A1, A0) = (0, 1, 0) will produce a logical '1' code at device output DQ0 for a write protected sector (See Table 3).

To terminate the Autoselect operation, it is necessary to write the read/reset command sequence into the register.

Table 6. Am29LV800 Command Definitions

Command Sequence Read/Reset (Note 2)		Bus Write Cycles Req'd	First Bus Write Cycle		Second Bus Read/Write Cycle		Third Bus Write Cycle		Fourth Bus Read/Write Cycle		Fifth Bus Write Cycle		Sixth Bus Write Cycle	
			Addr	Data	Addr	Data	Addr	Data	Addr	Data	Addr	Data	Addr	Data
Reset/Read	Word	1	XXX	XXF0	RA	RD								
	Byte			F0										
Autoselect Manufacturer ID	Word	3	555	XXAA	2AA	XX55	555	XX90	X00	XX01				
	Byte		AAA	AA	555	55	AAA	90	X00	01				
Autoselect Device ID (Top Boot Block)	Word	3	555	XXAA	2AA	XX55	555	XX90	X01	22DA				
	Byte		AAA	AA	555	55	AAA	90	X02	DA				
Autoselect Device ID (Bottom Boot Block)	Word	3	555	XXAA	2AA	XX55	555	XX90	X01	225B				
	Byte		AAA	AA	555	55	AAA	90	X02	5B				
Autoselect Sector Protect Verify (Note 3)	Word	3	555	XXAA	2AA	XX55	555	XX90	SA X02	XX00				
										XX01				
	Byte		AAA	AA	555	55	AAA	90	SA X04	00				
										01				
Program	Word	4	555	XXAA	2AA	XX55	555	XXA0	PA	PD				
	Byte		AAA	AA	555	55	AAA	A0						
Chip Erase	Word	6	555	XXAA	2AA	XX55	555	XX80	555	XXAA	2AA	XX55	555	XX10
	Byte		AAA	AA	555	55	AAA	80	AAA	AA	555	55	AAA	10
Sector Erase	Word	6	555	XXAA	2AA	XX55	555	XX80	555	XXAA	2AA	XX55	SA	XX30
	Byte		AAA	AA	555	55	AAA	80	AAA	AA	555	55		30
Erase Suspend (Note 4)	Word	1	XXX	XXB0										
	Byte			B0										
Erase Resume (Note 5)	Word	1	XXX	XX30										
	Byte			30										

Legend:

RA = Address of the memory location to be read.

RD = Data read from location RA during read operation.

PA = Address of the memory location to be programmed. Addresses are latched on the falling edge of the \overline{WE} or \overline{CE} pulse.

PD = Data to be programmed at location PA. Data is latched on the rising edge of \overline{WE} or \overline{CE} pulse.

SA = Address of the sector to be erased or verified. Address bits A18–A12 uniquely select any sector.

Notes:

- All values are in hexadecimal.
- See Tables 1 and 2 for description of bus operations.
- The data is 00h for an unprotected sector and 01h for a protected sector. The complete bus address is composed of the sector address on A18–A12 and 02h on A7–A0.
- Read and program functions in non-erasing sectors are allowed in the Erase Suspend mode. The Erase Suspend command is valid only during a sector erase operation.
- The Erase Resume command is valid only during the Erase Suspend mode.
- Unless otherwise noted, address bits A18–A11 = X = don't care.

Word/Byte Programming

The device can be programmed on a word or byte basis. Programming is a four-bus-cycle operation. There are two “unlock” write cycles. These are followed by the program command and address/data write cycles. Addresses are latched on the falling edge of \overline{CE} or \overline{WE} , whichever occurs later, while the data is latched on the rising edge of \overline{CE} or \overline{WE} , whichever occurs first. The rising edge of \overline{CE} or \overline{WE} , whichever occurs first, initiates programming using the Embedded Program Algorithm. Upon executing the write command, the system is **not** required to provide further controls or timing. The device will automatically provide adequate internally generated program pulses and verify the programmed cell margin.

The status of the Embedded Program Algorithm operation can be determined three ways:

- \overline{DATA} Polling of DQ7
- Checking the status of the toggle bit DQ6
- Checking the status of the RY/ \overline{BY} pin

Any commands written to the chip during the Embedded Program Algorithm will be ignored. If a hardware reset occurs during a programming operation, the data at that location will be corrupted.

Programming is allowed in any sequence and across sector boundaries. Beware that a data ‘0’ cannot be programmed back to a ‘1’. Attempting to do so will cause the device to exceed programming time limits (DQ5 = 1) or result in an apparent success according to the data polling algorithm. However, reading the device after executing the Read/Reset operation will show that the data is still ‘0’. Only erase operations can convert ‘0’s to ‘1’s.

Figure 7 illustrates the Embedded Program Algorithm, using typical command strings and bus operations.

Chip Erase

Chip erase is a six bus cycle operation. There are two “unlock” write cycles, followed by writing the erase “set up” command. Two more “unlock” write cycles are followed by the chip erase command.

Chip erase does **not** require the user to preprogram the device to all ‘0’s prior to erase. Upon executing the Embedded Erase Algorithm command sequence, the device automatically programs and verifies the entire memory to an all zero data pattern prior to electrical erase. The system is not required to provide any controls or timings during these operations.

The Embedded Erase Algorithm erase begins on the rising edge of the last \overline{WE} or \overline{CE} (whichever occurs first) pulse in the command sequence. The status of the Embedded Erase Algorithm operation can be determined three ways:

- \overline{DATA} Polling of DQ7
- Checking the status of the toggle bit DQ6
- Checking the status of the RY/ \overline{BY} pin

Figure 8 illustrates the Embedded Erase Algorithm, using a typical command sequence and bus operations.

Sector Erase

Sector erase is a six bus cycle operation. There are two “unlock” writes. These are followed by writing the erase “set up” command. Two more “unlock” writes are followed by the Sector Erase command (30h). The sector address (any address location within the desired sector) is latched on the falling edge of \overline{WE} or \overline{CE} (whichever occurs last) while the command (30h) is latched on the rising edge of \overline{WE} or \overline{CE} (whichever occurs first).

Multiple sectors can be specified for erase by writing the six bus cycle operation as described above and then following it by additional writes of the Sector Erase command to addresses of other sectors to be erased. The time between Sector Erase command writes must be less than 80 μ s, otherwise that command will not be accepted. It is recommended that processor interrupts be disabled during this time to guarantee this condition. The interrupts can be re-enabled after the last Sector Erase command is written. A time-out of 80 μ s from the rising edge of the last \overline{WE} (or \overline{CE}) will initiate the execution of the Sector Erase command(s). If another falling edge of the \overline{WE} (or \overline{CE}) occurs within the 80 μ s time-out window, the timer is reset. During the 80 μ s window, any command other than Sector Erase or Erase Suspend written to the device will reset the device back to Read mode. Once the 80 μ s window has timed out, only the Erase suspend command is recognized. Note that although the Reset command is not recognized in the Erase Suspend mode, the device is available for read or program operations in sectors that are not erase suspended. The Erase Suspended and Erase Resume commands may be written as often as required during a sector erase operation. Hence, once erase has begun, it must ultimately complete unless Hardware Reset is initiated. Loading the sector erase registers may be done in any sequence and with any number of sectors (0 to 18).

Sector erase does **not** require the user to program the device prior to erase. The device automatically preprograms all memory locations, within sectors to be erased, prior to electrical erase. When erasing a sector or sectors, the remaining unselected sectors or the write protected sectors are unaffected. The system is not required to provide any controls or timings during sector erase operations. The Erase Suspend and Erase Resume commands may be written as often as required during a sector erase operation.

Automatic sector erase operations begin on the rising edge of the \overline{WE} (or \overline{CE}) pulse of the last sector erase command issued, and once the 80 μs time-out window has expired. The status of the sector erase operation can be determined three ways:

- \overline{DATA} Polling of DQ7
- Checking the status of the toggle bit DQ6
- Checking the status of the $\overline{RY/BY}$ pin

Further status of device activity during the sector erase operation can be determined using toggle bits DQ2 and DQ3.

Figure 8 illustrates the Embedded Erase Algorithm, using a typical command sequence and bus operations.

Erase Suspend

The Erase Suspend command allows the user to interrupt a Sector Erase operation and then perform data read or programs in a sector not being erased. This command is applicable **only** during the Sector Erase operation, which includes the time-out period for Sector Erase. The Erase Suspend command will be ignored if written during the execution of the Chip Erase operation or Embedded Program Algorithm (but will reset the chip if written improperly during the command sequences.) Writing the Erase Suspend command during the Sector Erase time-out results in immediate termination of the time-out period and suspension of the erase operation. Once in Erase Suspend, the device is available for read (note that in the Erase Suspend mode, the Reset/Read command is not required for read operations and is ignored) or program operations in sectors not being erased. Any other command written during the Erase Suspend mode will be ignored, except for the Erase Resume command. Writing the Erase Resume command resumes the sector erase operation. The addresses are “don’t cares” when writing the Erase Suspend or Erase Resume command.

When the Erase Suspend command is written during a Sector Erase operation, the chip will take between 0.1 μs and 20 μs to actually suspend the operation and go into erase suspended read mode (pseudo-read mode),

at which time the user can read or program from a sector that is **not** erase suspended. Reading data in this mode is the same as reading from the standard read mode, except that the data must be read from sectors that have not been erase suspended.

Successively reading from the erase-suspended sector while the device is in the erase-suspend-read mode will cause DQ2 to toggle. Polling DQ2 on successive reads from a given sector provides the system the ability to determine if a sector is in Erase Suspend.

After entering the erase-suspend-read mode, the user can program the device by writing the appropriate command sequence for Byte Program. This program mode is known as the erase suspend-program mode. Again, programming in this mode is the same as programming in the regular Byte Program mode, except that the data must be programmed to sectors that are not erase suspended. Successively reading from the erase suspended sector while the device is in the erase suspend-program mode will cause DQ2 to toggle. Completion of the erase suspend operation can be determined two ways:

- Checking the status of the toggle bit DQ2
- Checking the status of the $\overline{RY/BY}$ pin

To resume the operation of Sector Erase, the Resume command (30h) should be written. Any further writes of the Resume command at this point will be ignored. However, another Erase Suspend command can be written after the device has resumed sector erase operations.

When the erase operation has been suspended, the device defaults to the erase-suspend-read mode. Reading data in this mode is the same as reading from the standard read mode except that the data must be read from sectors that have not been erase-suspended.

To resume the operation of Sector Erase, the Resume command (30h) should be written. Any further writes of the Resume command at this point will be ignored. Another Erase Suspend command can be written after the chip has resumed erasing.

Write Operation Status

Address Sensitivity of Write Status Flags

Detailed in Table 7 are all the status flags that can be used to check the status of the device for current mode operation. During Sector Erase, the part provides the status flags automatically to the I/O ports. The information on DQ2 is address sensitive. This means that if an address from an erasing sector is consecutively read, then the DQ2 bit will toggle. However, DQ2 will not toggle if an address from a non-erasing sector is consecutively read. This allows the user to determine which sectors are erasing and which are not.

Once Erase Suspend is entered, address sensitivity still applies. If the address of a non-erasing sector (that is, one available for read) is provided, then stored data can be read from the device. If the address of an erasing sector (that is, one unavailable for read) is applied, the device will output its status bits. Confirmation of status bits can be done by doing consecutive reads to toggle DQ2, which is active throughout the Embedded Erase mode, including Erase Suspend.

In order to effectively use $\overline{\text{DATA}}$ Polling to determine if the device has entered into erase-suspended mode, it is necessary to apply a sector address from a sector being erased.

Table 7. Hardware Sequence Flags

	Status		DQ7	DQ6	DQ5	DQ3	DQ2	RY/BY
In Progress	Byte and Word Programming		DQ7	Toggle	0	0	No Toggle	0
	Program/Erase in Auto-Erase		0	Toggle	0	1	(Note 1)	0
	Erase Suspend Mode	Erase Sector Address	1	No Toggle	0	0	Toggle (Note 1)	1
		Non-Erase Sector Address	Data	Data	Data	Data	Data (Note 2)	1
	Program in Erase Suspend		$\overline{\text{DQ7}}$ (Note 2)	Toggle	0	0	1 (Note 2)	0
Exceeded Time Limits	Byte and Word Programming		DQ7	Toggle	1	0	No Toggle	0
	Program/Erase in Auto-Erase		0	Toggle	1	1	(Note 3)	0
	Program in Erase Suspend		DQ7	Toggle	1	0	No Toggle	0

Notes:

1. DQ2 can be toggled when the sector address applied is that of an erasing or erase suspended sector. Conversely, DQ2 cannot be toggled when the sector address applied is that of a non-erasing or non-erase suspended sector. DQ2 is therefore used to determine which sectors are erasing or erase suspended and which are not.
2. These status flags apply when outputs are read from the address of a non-erase-suspended sector.
3. If DQ5 is high (exceeded timing limits), successive reads from a problem sector will cause DQ2 to toggle.

DQ7: $\overline{\text{DATA}}$ Polling

The Am29LV800 features $\overline{\text{DATA}}$ Polling as a method to indicate to the host system that the embedded algorithms are in progress or completed.

During the Embedded Program Algorithm, an attempt to read the device will produce the compliment of the data last written to DQ7. Upon completion of the Embedded Program Algorithm, an attempt to read the device will produce the true data last written to DQ7. Note that just at the instant when DQ7 switches to true data, the other bits, DQ6–DQ0, may not yet be true data. However, they will all be true data on the next read from the device. **Please note that $\overline{\text{DATA}}$ Polling (DQ7) may give an inaccurate result when an attempt is made to write to a protected sector.** During an Embedded

Erase Algorithm, an attempt to read the device will produce a '0' at the DQ7 output. Upon completion of the Embedded Erase Algorithm, an attempt to read the device will produce a '1' at DQ7.

For chip erase, the $\overline{\text{DATA}}$ Polling is valid (DQ7 = 1) after the rising edge of the sixth $\overline{\text{WE}}$ pulse in the six write pulse sequence. For sector erase, the $\overline{\text{DATA}}$ Polling is valid after the last rising edge of the sector erase $\overline{\text{WE}}$ pulse. $\overline{\text{DATA}}$ Polling must be performed at sector addresses within any of the sectors being erased and not a sector that is within a protected sector. Otherwise, the status may not be valid.

Just prior to the completion of Embedded Algorithm operations, DQ7 may change asynchronously while the output enable ($\overline{\text{OE}}$) is asserted low. This means that the

device is driving status information on DQ7 at one instant of time and then that byte's valid data at the next instant of time. Depending on when the system samples the DQ7 output, it may read the status or valid data. Even if the device has completed the Embedded Algorithm operations and DQ7 has valid data, DQ0–DQ6 may still provide write operation status. The valid data on DQ0–DQ7 can be read on the next successive read attempt.

The $\overline{\text{DATA}}$ Polling feature is only active during the Embedded Programming Algorithm, Embedded Erase Algorithm, Erase Suspend, erase suspend-program mode, or sector erase time-out (see Table 7).

If the user attempts to write to a protected sector, $\overline{\text{DATA}}$ Polling will be activated for about 1 μs ; the device will then return to read mode, with data from the protected sector unchanged. If the user attempts to erase a protected sector, Toggle Bit will be activated for about 50 μs ; the device will then return to read mode, without having erased the protected sector.

See Figure 18 for the $\overline{\text{DATA}}$ Polling timing specifications and diagrams.

DQ6: Toggle Bit

The Am29LV800 also features a “Toggle Bit” as a method to indicate to the host system whether the embedded algorithms are in progress or completed.

During an Embedded Program or Erase Algorithm, successive attempts to read data from the device will result in DQ6 toggling between one and zero. Once the Embedded Program or Erase Algorithm is completed, DQ6 will stop toggling and valid data can be read on the next successive attempts. During programming, the Toggle Bit is valid after the rising edge of the fourth $\overline{\text{WE}}$ pulse in the four-write-pulse sequence. During Chip erase, the Toggle Bit is valid after the rising edge of the sixth $\overline{\text{WE}}$ pulse in the six-write-pulse sequence. During Sector erase, the Toggle Bit is valid after the last rising edge of the sector erase $\overline{\text{WE}}$ pulse. The Toggle Bit is active during the Sector Erase time-out.

Either $\overline{\text{CE}}$ or $\overline{\text{OE}}$ toggling will cause DQ6 to toggle. If the user attempts to write to a protected sector, $\overline{\text{DATA}}$ Polling will be activated for about 1 μs ; the device will then return to read mode, with data from the protected sector unchanged. If the user attempts to erase a protected sector, Toggle Bit will be activated for about 50 μs ; the device will then return to read mode, without having erased the protected sector.

DQ5: Exceeded Timing Limits

DQ5 will indicate if the program or erase time has exceeded the specified limits (internal pulse count). Under these conditions, DQ5 will produce a ‘1’ indicating that the program or erase cycle was not successfully completed. Write operation status and reset command are the only operating functions under this

condition. The device will draw active power under this condition.

The DQ5 failure condition will also appear if the user attempts to write a data ‘1’ to a bit that has already been programmed to a data ‘0’. In this case, the DQ5 failure condition is not guaranteed to happen, since the device was incorrectly used. Please note that programming a data ‘0’ to a data ‘1’ should never be attempted, and only erasure should be used for this purpose. If programming to a data ‘1’ is attempted, the device should be reset.

If the DQ5 failure condition is observed while in Sector Erase mode (that is, exceeded timing limits), then DQ2 can be used to determine which sector had the problem. This is especially useful when multiple sectors have been loaded for erase.

DQ3: Sector Erase Timer

After the completion of the initial Sector Erase command sequence, the Sector Erase time-out will begin. DQ3 will remain low until the time-out is complete. $\overline{\text{DATA}}$ Polling (DQ7) and Toggle Bit (DQ6) are also valid after the first sector erase command sequence.

If $\overline{\text{DATA}}$ Polling or the Toggle Bit indicates the device has been written with a valid Sector Erase command, DQ3 may be used to determine if the sector erase timer window is still open. If DQ3 is high (‘1’), the internally controlled erase cycle has begun; attempts to write subsequent commands to the device will be ignored until the erase operation is completed as indicated by the $\overline{\text{DATA}}$ Polling or Toggle Bit. If DQ3 is low (‘0’), the device will accept additional sector erase commands. To be certain the command has been accepted, the software should check the status of DQ3 following each Sector Erase command. If DQ3 was high on the second status check, the command may not have been accepted.

It is recommended that the user guarantee the time between sector erase command writes be less than 80 μs by disabling the processor interrupts just for the duration of the Sector Erase (30h) commands. This approach will ensure that sequential sector erase command writes will be written to the device while the sector erase timer window is still open.

DQ2: Toggle Bit 2

This toggle bit, along with DQ6, can be used to determine whether the device is in the Embedded Erase Algorithm or in Erase Suspend.

Successive reads from the erasing sector will cause DQ2 to toggle during the Embedded Erase Algorithm. If the device is in the erase suspend-read mode, successive reads from the erase-suspended sector will cause DQ2 to toggle. When the device is in the erase suspend-program mode, successive reads from the byte address of the non-erase suspended sector will

indicate a logic '1' at the DQ2 bit. Note that a sector which is selected for erase is not available for read in Erase Suspend mode. Other sectors which are not selected for Erase can be read in Erase Suspend.

DQ6 is different from DQ2 in that DQ6 toggles only when the standard program or erase, or erase suspend-program operation is in progress.

If the DQ5 failure condition is observed while in Sector Erase mode (that is, exceeded timing limits), the DQ2 toggle bit can give extra information. In this case, the normal function of DQ2 is modified. If DQ5 is at logic '1', then DQ2 will toggle with consecutive reads only at the sector address that caused the failure condition. DQ2 will toggle at the sector address where the failure occurred and will not toggle at other sector addresses.

RY/BY: Ready/Busy Pin

The Am29LV800 provides a RY/BY open-drain output pin as a way to indicate to the host system that the

Embedded Algorithms are either in progress or have been completed. If the output is low, the device is busy with either a program or erase operation. If the output is high, the device is ready to accept any read/write or erase operation. When the RY/BY pin is low, the device will not accept any additional program or erase commands with the exception of the Erase Suspend command. If the Am29LV800 is placed in an Erase Suspend mode, the RY/BY output will be high. For programming, the RY/BY is valid (RY/BY=0) after the rising edge of the fourth WE pulse in the four write pulse sequence. For chip erase, the RY/BY is valid after the rising edge of the sixth WE pulse in the six write pulse sequence. For sector erase, the RY/BY is also valid after the rising edge of the sixth WE pulse.

Since the RY/BY pin is an open-drain output, several RY/BY pins can be tied together in parallel with a pull-up resistor to VCC.

Table 8. Toggle Bit Status

Mode	DQ7	DQ6	DQ2
Program	DQ7	Toggles	1
Erase	0	Toggles	Toggles
Erase-Suspend Read (Note 1) (Erase-Suspended Sector)	1	1	Toggles
Erase Suspend Program	DQ7 (Note 2)	Toggles	1 (Note 2)

Notes:

1. These status flags apply when outputs are read from a sector that has been erase suspended.
2. These status flags apply when outputs are read from the byte/word addresses of the non-erase suspended sector.

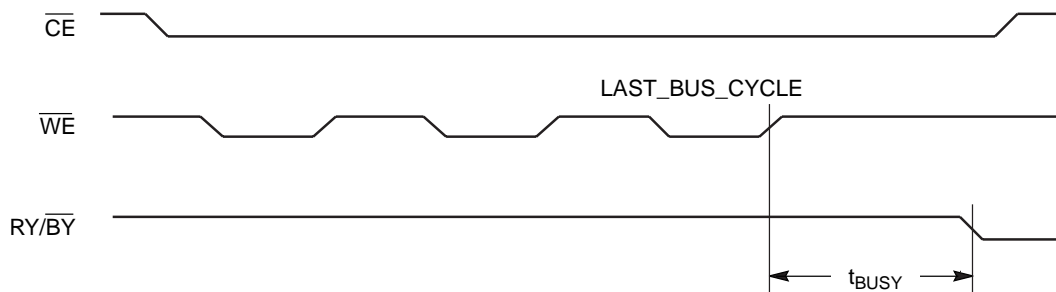

20478D-9

Figure 2. RY/BY Timing Diagram

RESET: Hardware Reset Pin

The RESET pin is an active low signal. A logic '0' on this pin will force the device out of any mode that is currently executing back to the reset state. This allows a system reset to take effect immediately without having to wait for the device to finish a long execution cycle. To avoid a potential bus contention during a system reset, the device is isolated from the data I/O bus by tri-stating the data output pins for the duration of the RESET pulse.

If RESET is asserted during a program or erase operation, the RY/BY pin will remain low until the reset operation is internally complete. This will require between 1 μs and 20 μs. Hence the RY/BY pin can be used to signal that the reset operation is complete. Otherwise, allow for the maximum reset time of 20 μs. If RESET is asserted when a program or erase operation is not executing (RY/BY pin is high), the reset operation will be complete within 500 ns.

Asserting RESET during a program or erase operation leaves erroneous data stored in the address locations being operated on at the time of device reset. These locations need updating after the reset operation is complete. See Figure 4 for timing specifications.

The device enters I_{CC4} standby mode (200 nA) when V_{SS} ± 0.3 V is applied to the RESET pin. The device can enter this mode at any time, regardless of the logical condition of the CE pin. Furthermore, entering I_{CC4} during a program or erase operation leaves erroneous data in the address locations being operated on at the time of the RESET pulse. These locations need updating after the device resumes standard operations. After the RESET pin goes high, a minimum latency period of 50 ns must occur before a valid read can take place.



20478D-10

Figure 3. Device Reset During a Program or Erase Operation

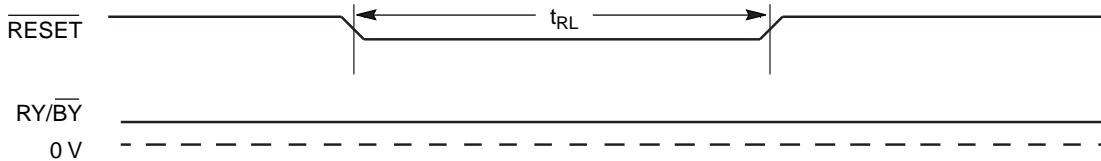

20478D-11

Figure 4. Device Reset During Read Mode

Word/Byte Configuration

The $\overline{\text{BYTE}}$ pin of the Am29LV800 is used to set device data I/O pins in the byte or word configuration. If the $\overline{\text{BYTE}}$ pin is set at logic '1', the device is in word configuration, DQ0–15 are active and controlled by $\overline{\text{CE}}$ and $\overline{\text{OE}}$ (see Figure 5).

If the $\overline{\text{BYTE}}$ pin is set at logic '0', the device is in byte configuration, and only data I/O pins DQ0–7 are active and controlled by $\overline{\text{CE}}$ and $\overline{\text{OE}}$. The data I/O pins DQ8–14 are tri-stated. In byte mode, the DQ15 pin is used as an input for the LSB (A-1) address function (see Figure 6).

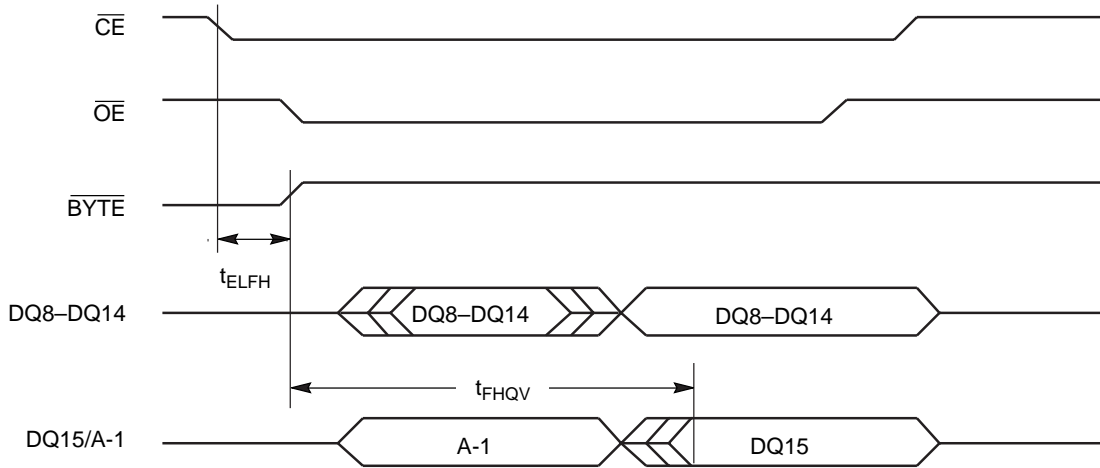

20478D-12

Figure 5. Timing Diagram for Word Mode Configuration

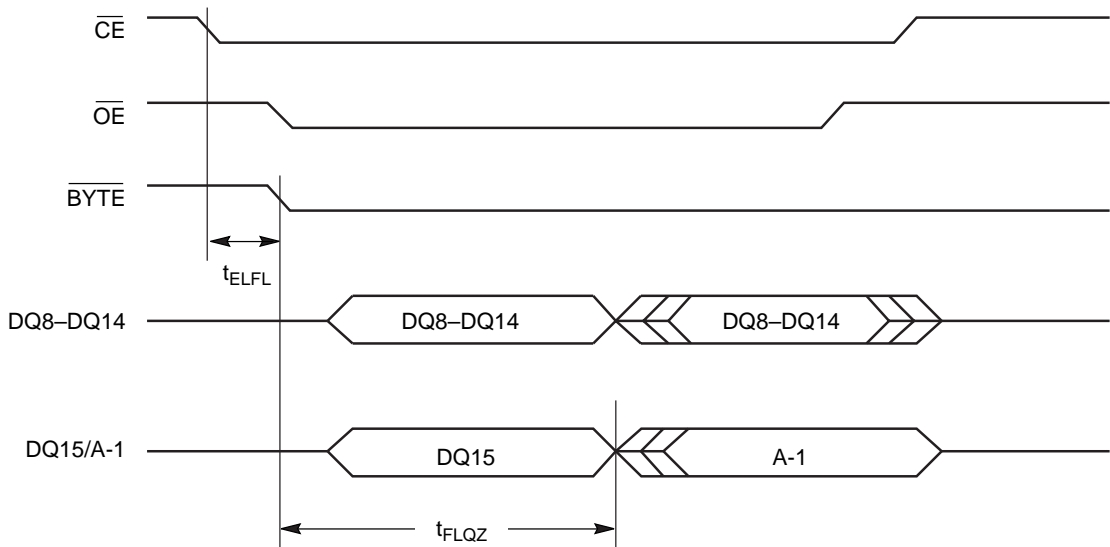

20478D-13

Figure 6. Timing Diagram for Byte Mode Configuration

Data Protection

The Am29LV800 is designed to offer protection against accidental erasure or programming caused by spurious system level signals that may exist during power transitions. During power-up, the device automatically resets the internal state machine to the read mode. Also, with its control register architecture, alteration of the memory contents only occurs after successful completion of the command sequences.

The Am29LV800 incorporates several features to prevent inadvertent write cycles resulting from V_{CC} power-up and power-down transitions or system noise.

Low V_{CC} Write Inhibit

To avoid initiation of a write cycle during V_{CC} power-up and power-down, a write cycle is locked out for V_{CC} less than V_{LKO} (lock-out voltage). If $V_{CC} < V_{LKO}$, the command register is disabled and all internal program/erase circuits are disabled. Under this condition, the device will reset to read mode. Subsequent writes will

be ignored until the V_{CC} level is greater than V_{LKO} . It is the user's responsibility to ensure that the control levels are logically correct when V_{CC} is above V_{LKO} (unless the \overline{RESET} pin is asserted).

Write Pulse "Glitch" Protection

Noise pulses of less than 5 ns (typical) on \overline{OE} , \overline{CE} , or \overline{WE} will not change the command registers.

Logical Inhibit

Writing is inhibited by holding any one of $\overline{OE} = V_{IL}$, $\overline{CE} = V_{IH}$, or $\overline{WE} = V_{IH}$. To initiate a write, \overline{CE} and \overline{WE} must be logical zero while \overline{OE} is a logical one.

Power-Up Write Inhibit

Power up of the device with $\overline{WE} = \overline{CE} = V_{IL}$ and $\overline{OE} = V_{IH}$ will not accept commands on the rising edge of \overline{WE} . The internal state machine is automatically reset to read mode on power up.

EMBEDDED ALGORITHMS

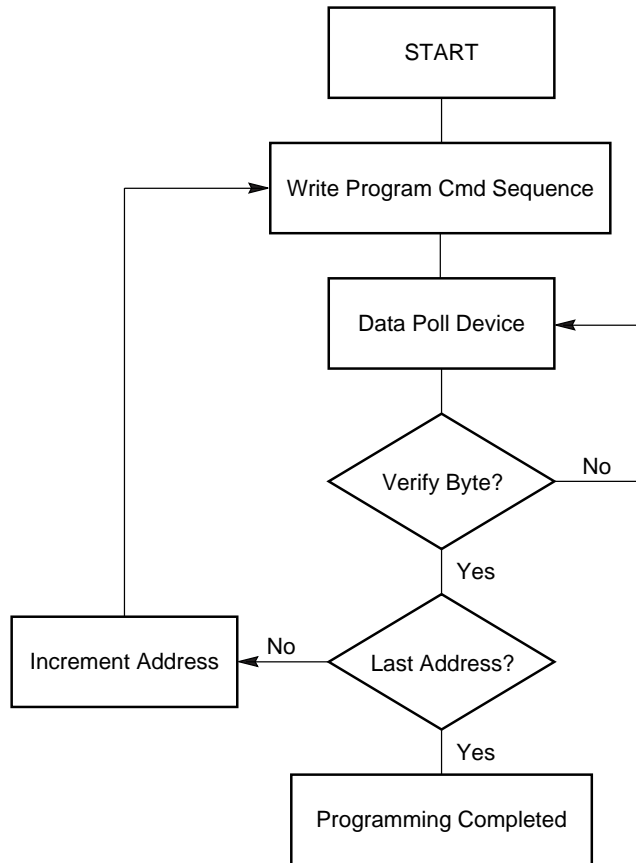

20478D-14

Figure 7. Embedded Program Algorithm

Embedded Program Algorithm

Bus Operation	Command Sequence	Comments
Standby*		
Write	Program	Valid Address/Data
Read		$\overline{\text{DATA}}$ Polling to Verify Programming
Standby*		Compare Data Output to Data Expected

* Device is either powered-down, erase inhibit, or program inhibit.

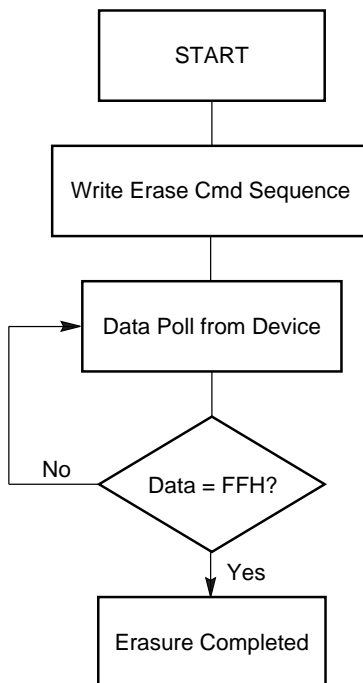

20478D-15

Figure 8. Embedded Erase Algorithm

Embedded Erase Algorithm

Bus Operation	Command Sequence	Comments
Standby		
Write	Erase	
Read		$\overline{\text{DATA}}$ Polling to Verify Erasure
Standby		Compare Output to FFh

Data Polling Algorithm

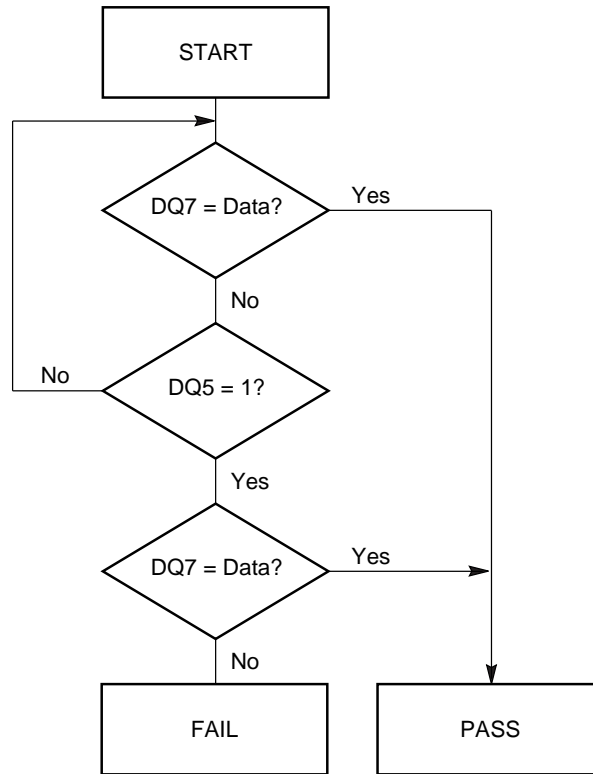

20478D-16

Figure 9. Data Polling Algorithm

Toggle Bit Algorithm

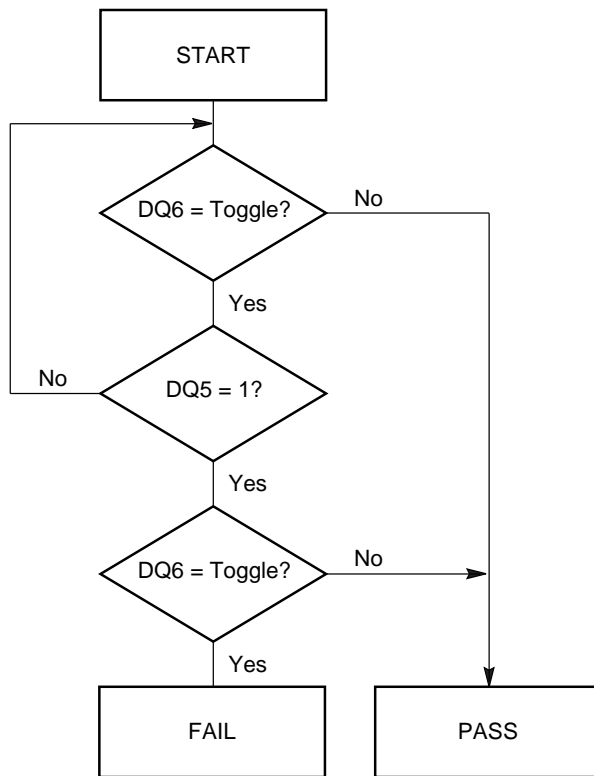

20478D-17

Figure 10. Toggle Bit Algorithm

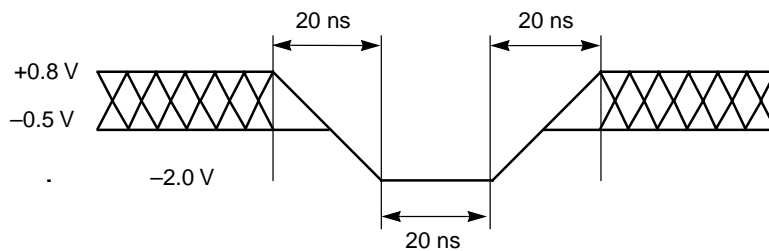

20478D-18

Figure 11. Maximum Negative Overshoot Waveform

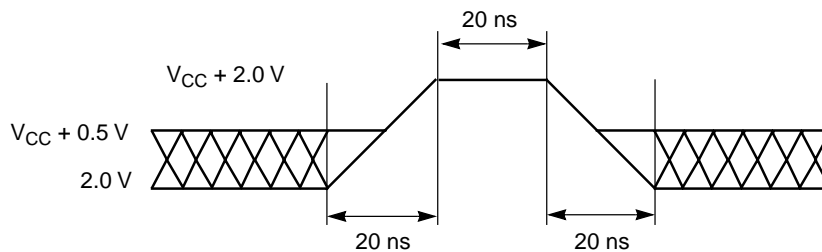

20478D-19

Figure 12. Maximum Positive Overshoot Waveform

ABSOLUTE MAXIMUM RATINGS

Storage Temperature	
Plastic Packages	-65°C to +150°C
Ambient Temperature	
with Power Applied.	-55°C to +125°C
Voltage with Respect to Ground	
All pins except A9 (Note 1).	-0.5 V to $V_{CC} + 4.5$ V
V_{CC} (Note 1).	-0.5 V to +5.5 V
RESET, OE, A9 (Note 2)	-0.5 V to +13.0 V
Output Short Circuit Current (Note 3)	200 mA

Notes:

1. Minimum DC voltage on input or I/O pins is -0.5 V. During voltage transitions, inputs may overshoot V_{SS} to -2.0 V for periods of up to 20 ns. Maximum DC voltage on input and I/O pins is $V_{CC} + 0.5$ V. During voltage transitions, input and I/O pins may overshoot to $V_{CC} + 2.0$ V for periods up to 20ns.
2. Minimum DC input voltage on A9 pin is -0.5 V. During voltage transitions, A9 may overshoot V_{SS} to -2.0 V for periods of up to 20 ns. Maximum DC input voltage on A9 is +13.5 V which may overshoot to 14.0 V for periods up to 20 ns.
3. No more than one output shorted at a time. Duration of the short circuit should not be greater than one second.

Stresses above those listed under "Absolute Maximum Ratings" may cause permanent damage to the device. This is a stress rating only; functional operation of the device at these or any other conditions above those indicated in the operational sections of this specification is not implied. Exposure of the device to absolute maximum rating conditions for extended periods may affect device reliability.

OPERATING RANGES**Commercial (C) Devices**

Ambient Temperature (T_A). 0°C to +70°C

Industrial (I) Devices

Ambient Temperature (T_A). -40°C to +85°C

Extended (E) Devices

Ambient Temperature (T_A). -55°C to +125°C

 V_{CC} Supply Voltages

V_{CC} for Am29LV800T/B-90R. +3.0 V to 3.6 V

V_{CC} for Am29LV800T/B-100,
-120, -150 +2.7 V to 3.6 V

Operating ranges define those limits between which the functionality of the device is guaranteed.

DC CHARACTERISTICS

CMOS Compatible

Parameter Symbol	Parameter Description	Test Conditions	Min	Max	Unit
I_{LI}	Input Load Current	$V_{IN} = V_{SS}$ to V_{CC} ; $V_{CC} = V_{CC\ max}$		± 1.0	μA
I_{LIT}	A9 Input Load Current	$V_{CC} = V_{CC\ max}$; A9 = 13.0 V		35	μA
I_{LO}	Output Leakage Current	$V_{OUT} = V_{SS}$ to V_{CC} ; $V_{CC} = V_{CC\ max}$		± 1.0	μA
I_{CC1}	V_{CC} Active Current (Note 1)	$\overline{CE} = V_{IL}$, $\overline{OE} = V_{IH}$, Byte Mode	5 MHz	16	mA
			1 MHz	4	
		$\overline{CE} = V_{IL}$, $\overline{OE} = V_{IH}$, Word Mode	5 MHz	16	
			1 MHz	4	
I_{CC2}	V_{CC} Active Current (Notes 2 and 4)	$\overline{CE} = V_{IL}$, $\overline{OE} = V_{IH}$		30	mA
I_{CC3}	V_{CC} Standby Current	$V_{CC} = V_{CC\ max}$; \overline{CE} , RESET = $V_{CC} \pm 0.3$ V		5	μA
I_{CC4}	V_{CC} Reset Current	$V_{CC} = V_{CC\ max}$; RESET = $V_{SS} \pm 0.3$ V		5	μA
I_{CC5}	Automatic Sleep Mode (Note 3)	$V_{IH} = V_{CC} \pm 0.3$ V; $V_{IL} = V_{SS} \pm 0.3$ V		5	μA
V_{IL}	Input Low Voltage		-0.5	0.8	V
V_{IH}	Input High Voltage		$0.7 \times V_{CC}$	$V_{CC} + 0.3$	V
V_{ID}	Voltage for Autoselect and Temporary Sector Unprotect	$V_{CC} = 3.3$ V	11.5	12.5	V
V_{OL}	Output Low Voltage	$I_{OL} = 4.0$ mA, $V_{CC} = V_{CC\ min}$		0.45	V
V_{OH1}	Output High Voltage	$I_{OH} = -2.0$ mA, $V_{CC} = V_{CC\ min}$	$0.85 V_{CC}$		V
V_{OH2}		$I_{OH} = -100$ μA , $V_{CC} = V_{CC\ min}$	$V_{CC} - 0.4$		
V_{LKO}	Low V_{CC} Lock-Out Voltage (Note 4)		2.3	2.5	V

Notes:

1. The I_{CC} current listed includes both the DC operating current and the frequency dependent component (at 5 MHz). The frequency component typically is less than 2 mA/MHz, with \overline{OE} at V_{IH} .
2. I_{CC} active while Embedded Erase or Embedded Program is in progress.
3. Automatic sleep mode enables the low power mode when addresses remain stable for 200 ns. Typical sleep mode current is 200 nA.
4. Not 100% tested.

DC CHARACTERISTICS (Continued)

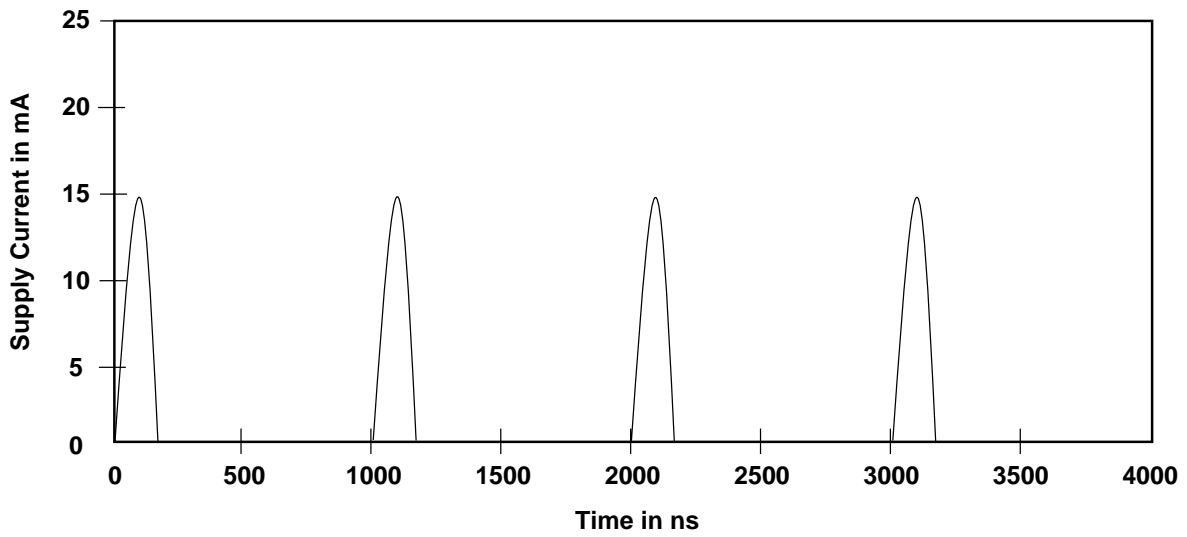

Note: Addresses are switching at 1 MHz

20478D-20

Figure 13A. I_{CC} Current vs. Time

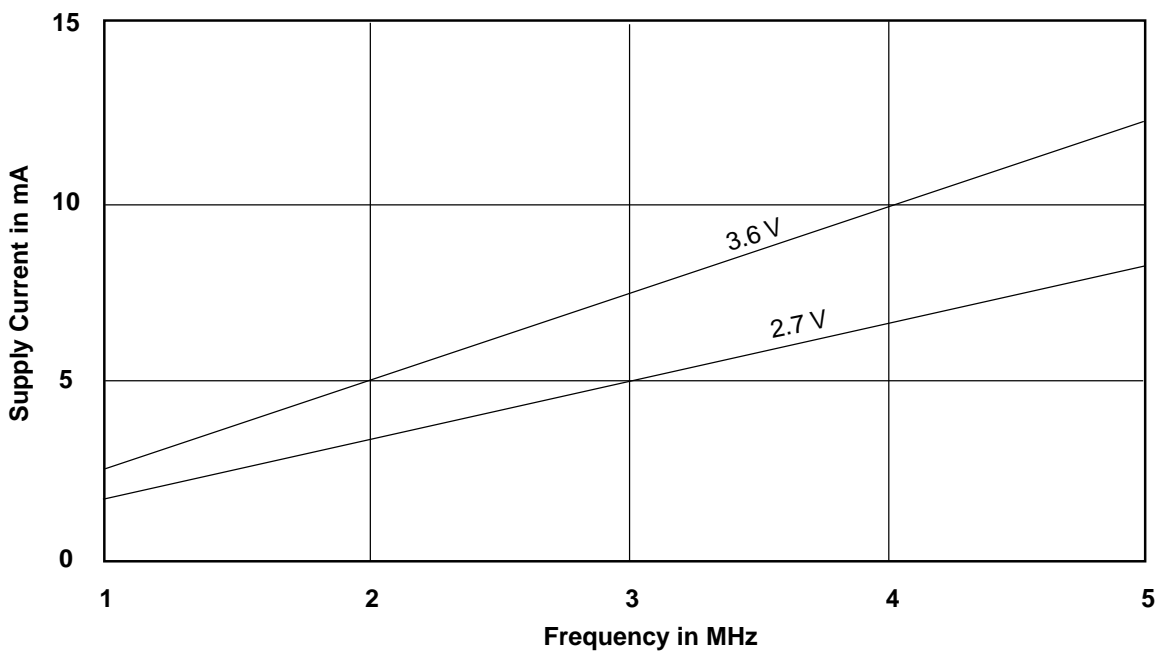

Note: $T = 25^{\circ}C$

20478D-21

Figure 13B. I_{CC} vs. Frequency

DC CHARACTERISTICS (Continued)

TTL/NMOS Compatible

Parameter Symbol	Parameter Description	Test Description	Min	Max	Unit
I_{LI}	Input Load Current	$V_{IN} = V_{SS}$ to V_{CC} , $V_{CC} = V_{CC\ MAX}$		± 1.0	μA
I_{LIT}	A9 Input Load Current	$V_{CC} = V_{CC\ MAX}$, $A9 = V_{ID}$		35	μA
I_{LO}	Output Leakage Current	$V_{OUT} = V_{SS}$ to V_{CC} , $V_{CC} = V_{CC\ MAX}$		± 1.0	μA
I_{CC1}	V_{CC} Active Read Current (Note 1)	$\overline{CE} = V_{IL}$, $\overline{OE} = V_{IH}$	Byte	30	mA
			Word	35	
I	V_{CC} Active Write Current (Note 2)	$\overline{CE} = V_{IL}$, $\overline{OE} = V_{IH}$		35	mA
I_{CC3}	V_{CC} Standby Current	$V_{CC} = V_{CC\ MAX}$, $\overline{CE} = V_{IH}$, $\overline{RESET} = V_{IH}$		250	μA
I_{CC4}	V_{CC} Standby Current During Reset	$V_{CC} = V_{CC\ MAX}$, $\overline{CE} = V_{IH}$, $\overline{RESET} = V_{IL}$		250	μA
I_{CC5}	Automatic Sleep Mode (Note 3)	$\overline{CE} = V_{IL}$, $\overline{OE} = V_{IH}$		250	μA
V_{IL}	Input Low Level		-0.5	0.8	V
V_{IH}	Input High Level		2.0	$V_{CC} + 0.5$	V
V_{ID}	Voltage for Autoselect and Sector Protect		11.5	12.5	V
V_{OL}	Output Low Level	$I_{OL} = 4.0\ mA$, $V_{CC} = V_{CC\ MIN}$		0.45	V
V_{OH}	Output High Level	$I_{OH} = -2.0\ mA$, $V_{CC} = V_{CC\ MIN}$	2.4		V
V_{LKO}	Low V_{CC} Lock-Out Voltage (Note 4)		2.3	2.5	V

$V_{CC} = 2.7\ V$ to $3.6\ V$

Notes:

1. The I_{CC} current listed includes both the DC operating current and the frequency dependent component (at 5 MHz). The frequency component typically is less than 2 mA/MHz, with \overline{OE} at V_{IH} .
2. I_{CC} active while Embedded Algorithm (program or erase) is in progress.
3. Automatic sleep mode enables the low power mode when addresses remain stable for 300 ns. Typical sleep mode current is 80 μA .
4. Not 100% tested.

AC CHARACTERISTICS

Read-Only Operations Characteristics

Parameter Symbols		Description	Test Setup	Speed Option (Note 1)				Unit
JEDEC	Standard			-90R	-100	-120	-150	
t_{AVAV}	t_{RC}	Read Cycle Time (Note 3)	Min	90	100	120	150	ns
t_{AVQV}	t_{ACC}	Address to Output Delay	$\overline{CE} = V_{IL}$ $\overline{OE} = V_{IL}$ Max	90	100	120	150	ns
t_{ELQV}	t_{CE}	Chip Enable to Output Delay	$\overline{OE} = V_{IL}$ Max	90	100	120	150	ns
t_{GLQV}	t_{OE}	Output Enable to Output Delay	Max	40	40	50	55	ns
t_{EHQZ}	t_{DF}	Chip Enable to Output High Z (Notes 2, 3)	Max	30	30	30	40	ns
t_{GHQZ}	t_{DF}	Output Enable to Output High Z (Notes 2, 3)	Max	30	30	30	40	ns
t_{AXQX}	t_{OH}	Output Hold Time From Addresses, \overline{CE} or \overline{OE} , Whichever Occurs First (Note 3)	Min	0	0	0	0	ns
	t_{Ready}	\overline{RESET} Pin Low to Read Mode (Note 3)	Max	20	20	20	20	μs

Notes:

1. Test Conditions
 Input Rise and Fall Times: 5 ns
 Input Pulse Levels: 0.0 V to 3.0 V
 Timing Measurement Reference Level:
 Input: 1.5 V
 Output: 1.5 V
2. Output Driver Disable Time
3. Not 100% tested.

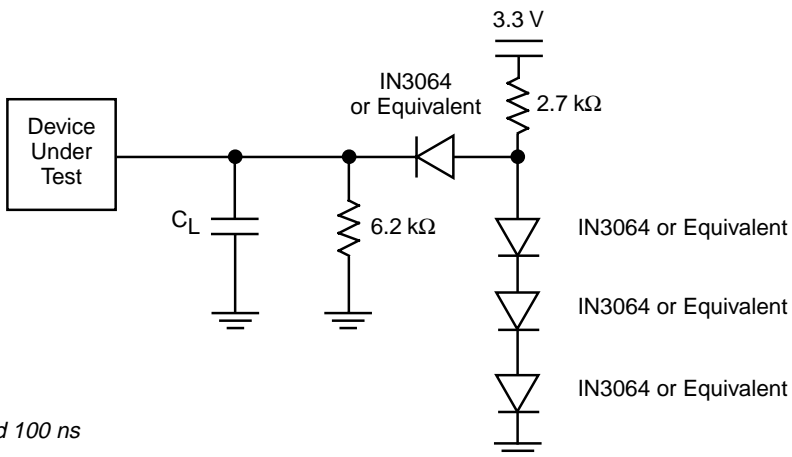

Notes:

- $C_L = 30$ pF for 90 and 100 ns
- $C_L = 100$ pF for 120 and 150 ns

Figure 14. Test Conditions

20478D-15

AC CHARACTERISTICS



Write (Erase/Program) Operations

Parameter Symbols		Description						Unit
JEDEC	Standard							
t_{AVAV}	t_{WC}	Write Cycle Time (Note 2)	Min	90	100	120	150	ns
t_{AVWL}	t_{AS}	Address Setup Time	Min	0	0	0	0	ns
t_{WLAX}	t_{AH}	Address Hold Time	Min	50	50	50	65	ns
t_{DVWH}	t_{DS}	Data Setup Time	Min	50	50	50	65	ns
t_{WHDX}	t_{DH}	Data Hold Time	Min	0	0	0	0	ns
	t_{OES}	Output Enable Setup Time (Note 2)	Min	0	0	0	0	ns
	t_{OEH}	Output Enable Hold Time	Read (Note 2)	Min	0	0	0	ns
			Toggle and $\overline{\text{Data}}$ Polling (Note 2)	Min	10	10	10	10
t_{GHWL}	t_{GHWL}	Read Recovery Time Before Write (OE High to WE Low)	Min	0	0	0	0	ns
t_{ELWL}	t_{CS}	$\overline{\text{CE}}$ Setup Time	Min	0	0	0	0	ns
t_{WHEH}	t_{CH}	$\overline{\text{CE}}$ Hold Time	Min	0	0	0	0	ns
t_{WLWH}	t_{WP}	Write Pulse Width	Min	50	50	50	65	ns
t_{WHDL}	t_{WPH}	Write Pulse Width High	Min	30	30	30	35	ns
t_{WHWH1}	t_{WHWH1}	Programming Operation	Byte	Typ	9	9	9	μs
			Word	Typ	11	11	11	
t_{WHWH2}	t_{WHWH2}	Sector Erase Operation (Note 1)	Typ	1	1	1	1	sec
	t_{VCS}	V_{CC} Setup Time	Min	50	50	50	50	μs
	t_{RB}	Write Recovery Time from RY/ $\overline{\text{BY}}$	Min	0	0	0	0	ns
	t_{RH}	$\overline{\text{RESET}}$ High Time Before Read	Min	50	50	50	50	ns
	t_{RPD}	$\overline{\text{RESET}}$ To Power Down Time	Min	20	20	20	20	μs
	t_{BUSY}	Program/Erase Valid to RY/ $\overline{\text{BY}}$ Delay	Min	90	90	90	90	ns
	t_{ELFL}/t_{ELFH}	$\overline{\text{CE}}$ to $\overline{\text{BYTE}}$ Switching Low or High	Max	5	5	5	5	ns
	t_{FLQZ}	$\overline{\text{BYTE}}$ Switching Low to Output HIGH Z	Min	30	30	40	40	ns
	t_{FHQV}	$\overline{\text{BYTE}}$ Switching High to Output Active	Min	30	30	40	40	ns
	t_{VIDR}	Rise Time to V_{ID}	Min	500	500	500	500	ns
	t_{RP}	$\overline{\text{RESET}}$ Pulse Width	Min	500	500	500	500	ns
	t_{RRB}	$\overline{\text{RESET}}$ Low to RY/ $\overline{\text{BY}}$ High	Max	20	20	20	20	μs
	t_{RSP}	$\overline{\text{RESET}}$ Setup Time for Temporary Sector Unprotect	Min	4	4	4	4	μs

Notes:

1. The duration of the program or erase operation is variable and is calculated in the internal algorithms.
2. Note 100% tested.

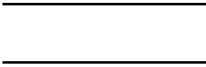
KEY TO SWITCHING WAVEFORMS

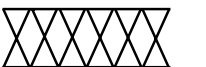
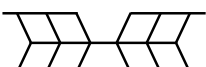
WAVEFORM	INPUTS	OUTPUTS
	Must be Steady	Will be Steady
	May Change from H to L	Will be Changing from H to L
	May Change from L to H	Will be Changing from L to H
	Don't Care, Any Change Permitted	Changing, State Unknown
	Does Not Apply	Center Line is High-Impedance "Off" State

KS000010-PAL

SWITCHING WAVEFORMS

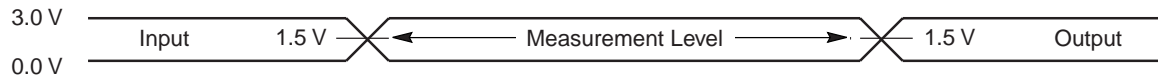

20478D-16

Figure 15. Input Waveforms and Measurement Levels

SWITCHING WAVEFORMS

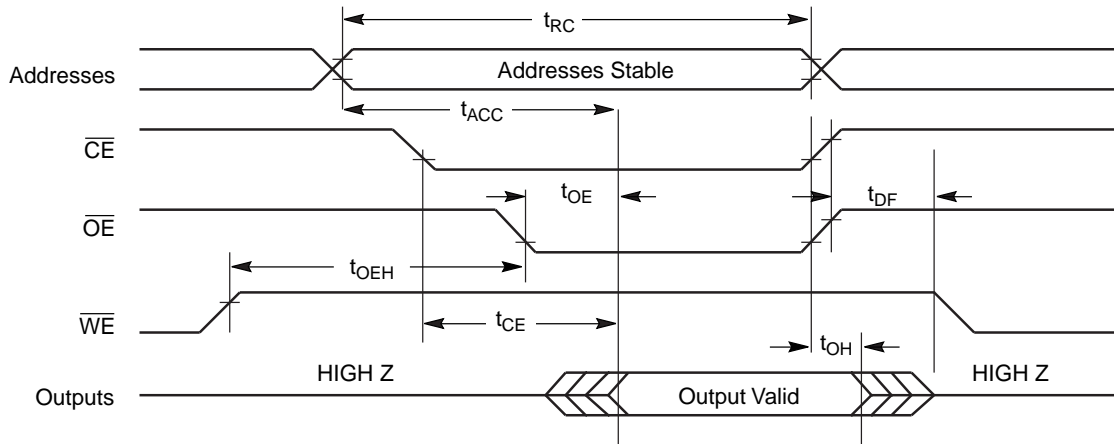

20478D-17

Figure 16. AC Waveforms for Read Operations

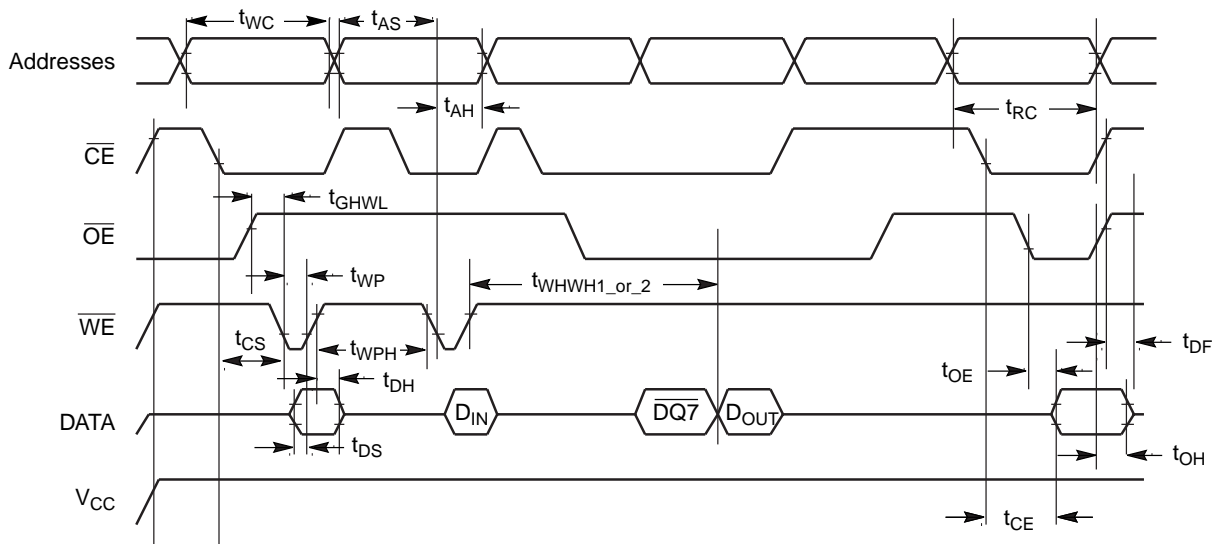

Notes:

1. D_{IN} is the data input to the device.
2. $DQ7$ is the output of the complement of the data written to the device.
3. D_{OUT} is the output of the data written to the device.

20478D-18

Figure 17. Program Operations Timings

SWITCHING WAVEFORMS

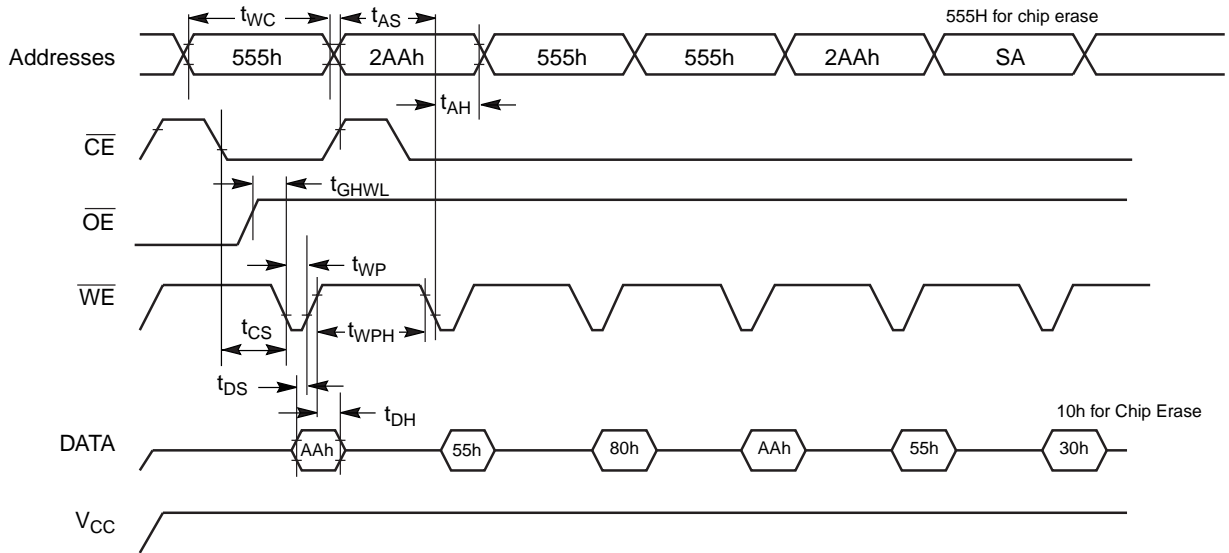

Notes:

1. SA is the sector address for Sector Erase. Addresses = Don't Care for Chip Erase.
2. These waveforms are for the x16 mode.

20478D-19

Figure 18. AC Waveforms for Chip/Sector Erase Operations

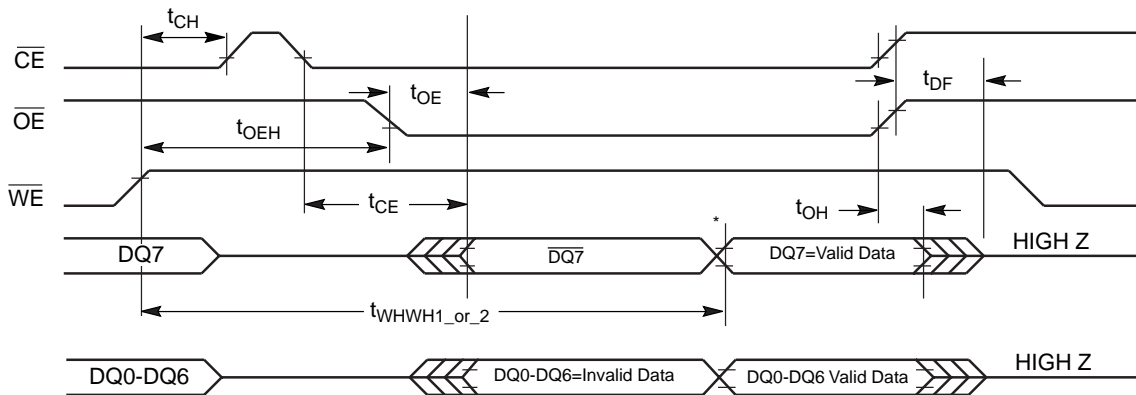

Note:

DQ7 = Valid Data (The device has completed the embedded operation.)

20478D-20

Figure 19. AC Waveforms for Data Polling During Embedded Algorithm Operations

SWITCHING WAVEFORMS

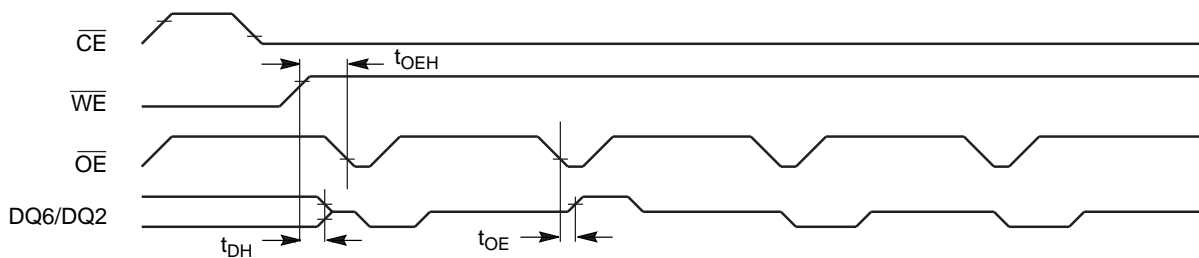

Note:
DQ6 stops toggling (The device has completed the embedded operation.)

20478D-21

Figure 20. Toggle Bit Timings (During Embedded Algorithm Operations)

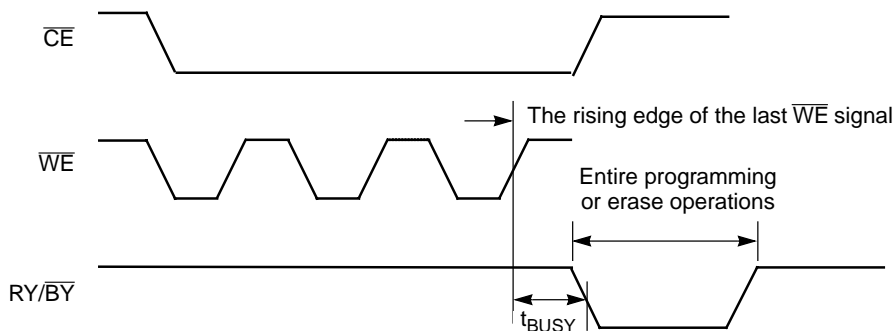

Note:
DQ7 = Valid Data (The device has completed the embedded operation.)

20478D-22

Figure 21. RY/BY Timing Diagram (During Program/Erase Operations)

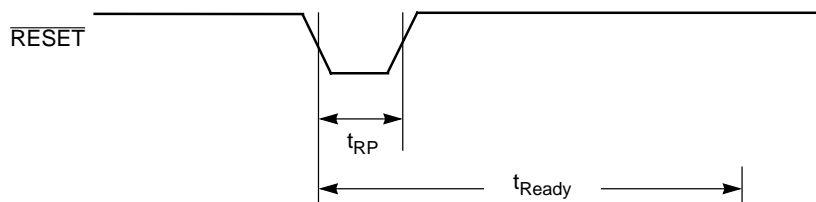

20478D-23

Figure 22. RESET Timing Diagram

SWITCHING WAVEFORMS

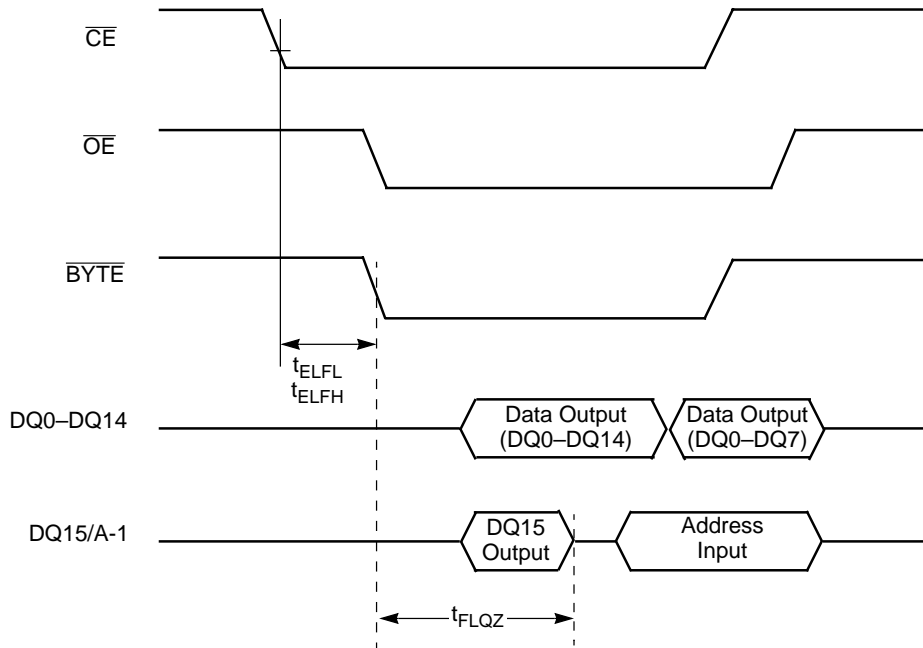

20478D-24

Figure 23. \overline{BYTE} Timing Diagram for Read Operation

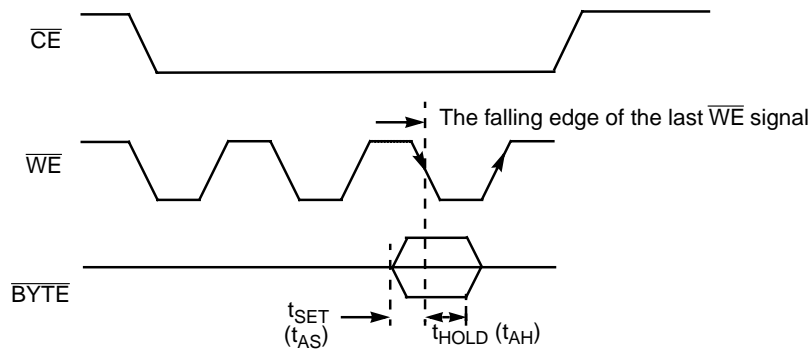

20478D-25

Figure 24. \overline{BYTE} Timing Diagram for Write Operations

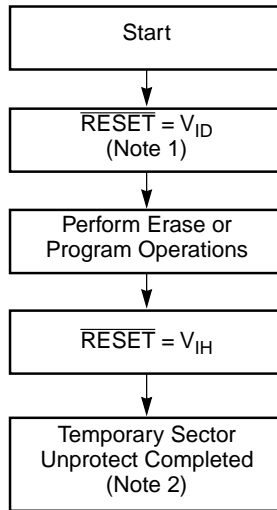

Notes:

- 1. All protected sectors unprotected.
- All previously protected sectors are protected once again.

20478D-26

Figure 25. Temporary Sector Unprotect Algorithm

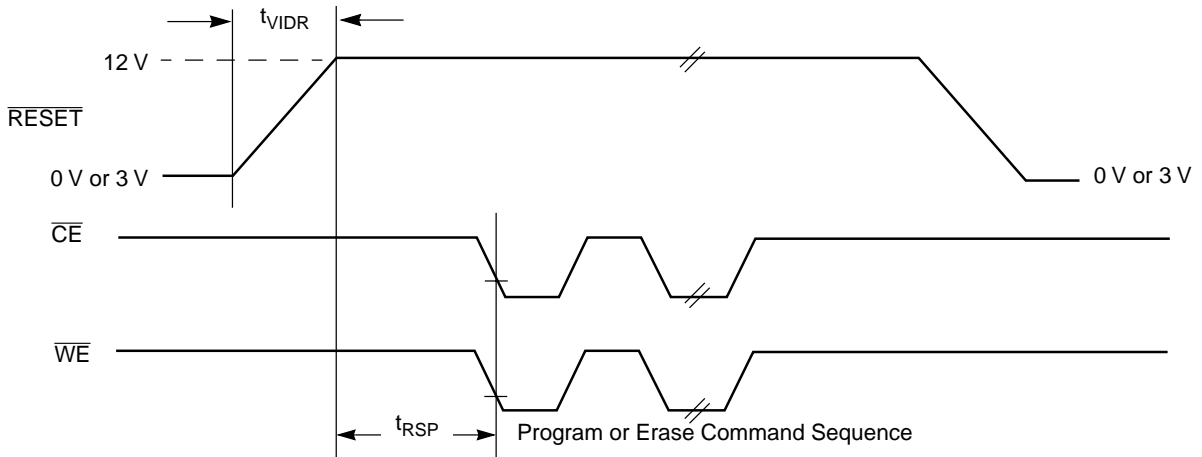

20478D-27

Figure 26. Temporary Sector Unprotect Timing Diagram

AC CHARACTERISTICS

Write (Erase/Program) Operations

Alternate \overline{CE} Controlled Writes

Parameter Symbols									
JEDEC	Standard	Description			-90R	-100	-120	-150	Unit
t_{AVAV}	t_{WC}	Write Cycle Time (Note 2)		Min	90	100	120	150	ns
t_{AVWL}	t_{AS}	Address Setup Time		Min	0	0	0	0	ns
t_{ELAX}	t_{AH}	Address Hold Time		Min	50	50	50	65	ns
t_{DVEH}	t_{DS}	Data Setup Time		Min	50	50	50	65	ns
t_{EHDX}	t_{DH}	Data Hold Time		Min	0	0	0	0	ns
	t_{OES}	Output Enable Setup Time		Min	0	0	0	0	ns
	t_{OEH}	Output Enable Hold Time	Read (Note 2)	Min	0	0	0	0	ns
			Toggle and \overline{Data} Polling (Note 2)	Min	10	10	10	10	ns
t_{GHLEL}	t_{GHLEL}	Read Recovery Time Before Write (\overline{OE} High to \overline{WE} Low)		Min	0	0	0	0	ns
t_{WLEL}	t_{WS}	\overline{WE} Setup Time		Min	0	0	0	0	ns
t_{EHWH}	t_{WH}	\overline{WE} Hold Time		Min	0	0	0	0	ns
t_{ELEH}	t_{CP}	\overline{CE} Pulse Width		Min	50	50	50	65	ns
t_{EHEL}	t_{CPH}	\overline{CE} Pulse Width High		Min	30	30	30	35	ns
t_{WHWH1}	t_{WHWH1}	Programming Operation	Byte	Typ	9	9	9	9	μ s
			Word	Typ	11	11	11	11	
t_{WHWH2}	t_{WHWH2}	Sector Erase Operation (Note 1)		Typ	1	1	1	1	sec
	t_{FLQZ}	BYTE Switching Low to Output HIGH Z (Note 2)		Min	30	30	30	30	ns

Notes:

1. The duration of the program or erase operation is variable and is calculated in the internal algorithms.
2. Does not include the preprogramming time.
3. Not 100% tested.

SWITCHING WAVEFORMS

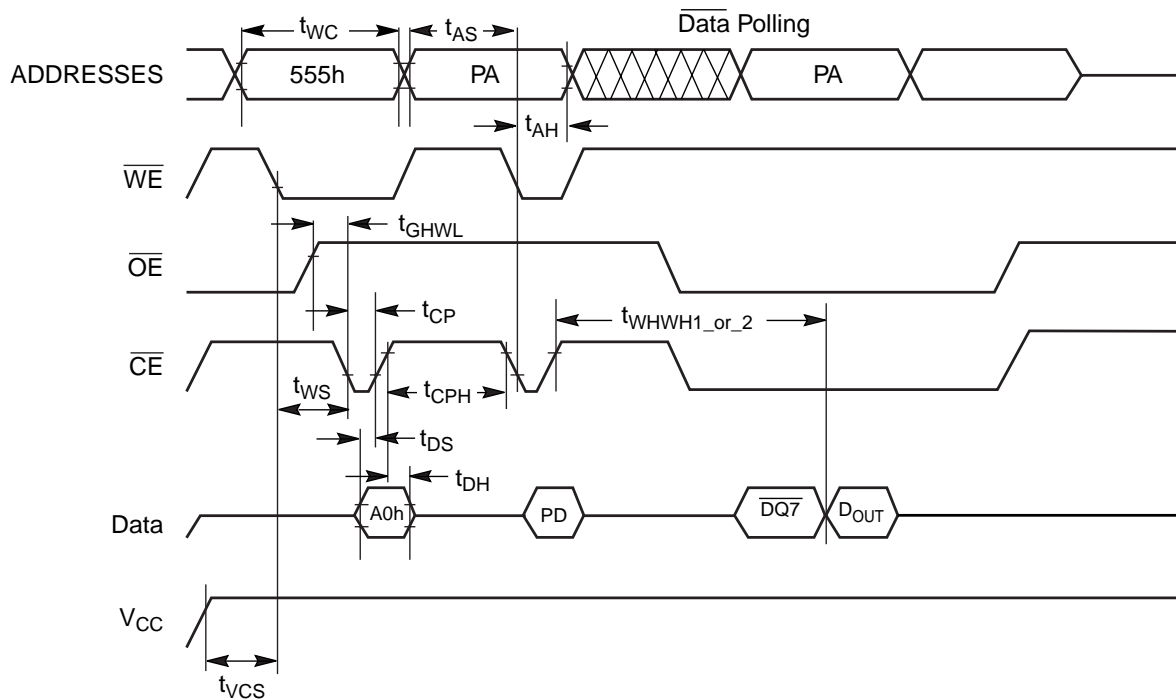

20478D-33

Notes:

1. PA is address of the memory location to be programmed.
2. PD is data to be programmed at byte address.
3. $\overline{DQ7}$ is the complement of the data written to the device.
4. D_{OUT} is the data written to the device.

Figure indicates last two bus cycles of four bus cycle sequence

Figure 27. Alternate \overline{CE} Controlled Write Operation Timings

ERASE AND PROGRAMMING PERFORMANCE

Parameter	Typ (Note 2)	Max (Note 3)	Unit	Comments
Sector Erase Time	1	15	s	Excludes 00h programming prior to erasure (Note 4)
Chip Erase Time	19		s	
Byte Programming Time	9	300	μ s	Excludes system level overhead (Note 5)
Word Programming Time	11	360	μ s	
Chip Programming Time	Byte Mode	9	s	
	Word Mode	5.8	s	
Erase/Program Endurance	1,000,000		cycles	Minimum 100,000 cycles guaranteed

Notes:

1. The typical program and erase times are considerably less than the maximum times since most words/bytes program or erase significantly faster than the worst case word/byte. The device enters the failure mode (DQ5="1") only after the maximum times given are exceeded. See the section on DQ5 for further information.
2. Except for erase and program endurance, the typical program and erase times assume the following conditions: 25°C, 3.0 V V_{CC} , 100,000 cycles. Additionally, programming typicals assume checkerboard pattern.
3. Under worst case conditions of 90°C, $V_{CC} = 2.7$ V, 100,000 cycles.
4. In the pre-programming step of the Embedded Erase algorithm, all bytes are programmed to 00h before erasure.
5. System-level overhead is the time required to execute the four-bus-cycle sequence for the program command. See Table 6 for further information on command definitions.

LATCHUP CHARACTERISTICS

	Min	Max
Input Voltage with respect to V_{SS} on all pins except I/O pins (Including A9 and \overline{OE})	-1.0 V	13.0 V
Input Voltage with respect to V_{SS} on all I/O pins	-1.0 V	$V_{CC} + 1.0$ V
Current	-100 mA	+100 mA

Includes all pins except V_{CC} . Test conditions: $V_{CC} = 3.0$ V, one pin at a time.

PIN CAPACITANCE, 48-PIN TSOP

Parameter Symbol	Parameter Description	Test Setup	Typ	Max	Unit
C_{IN}	Input Capacitance	$V_{IN} = 0$	6	7.5	pF
C_{OUT}	Output Capacitance	$V_{OUT} = 0$	8.5	12	pF
C_{IN2}	Control Pin Capacitance	$V_{IN} = 0$	8	10	pF

Notes:

1. Sampled, not 100% tested.
2. Test conditions $T_A = 25^\circ$ C, $f = 1.0$ MHz.

PIN CAPACITANCE, 44-PIN PSOP

Parameter Symbol	Parameter Description	Test Setup	Typ	Max	Unit
C_{IN}	Input Capacitance	$V_{IN} = 0$	6	7.5	pF
C_{OUT}	Output Capacitance	$V_{OUT} = 0$	8.5	12	pF
C_{IN2}	Control Pin Capacitance	$V_{IN} = 0$	8	10	pF

Notes:

1. Sampled, not 100% tested.
2. Test conditions $T_A = 25^\circ\text{C}$, $f = 1.0\text{ MHz}$.

DATA RETENTION

Parameter	Test Conditions	Min	Unit
Minimum Pattern Data Retention Time	150°C	10	Years
	125°C	20	Years

PHYSICAL DIMENSIONS*

TS 048

48-Pin Standard Thin Small Outline Package (measured in millimeters)

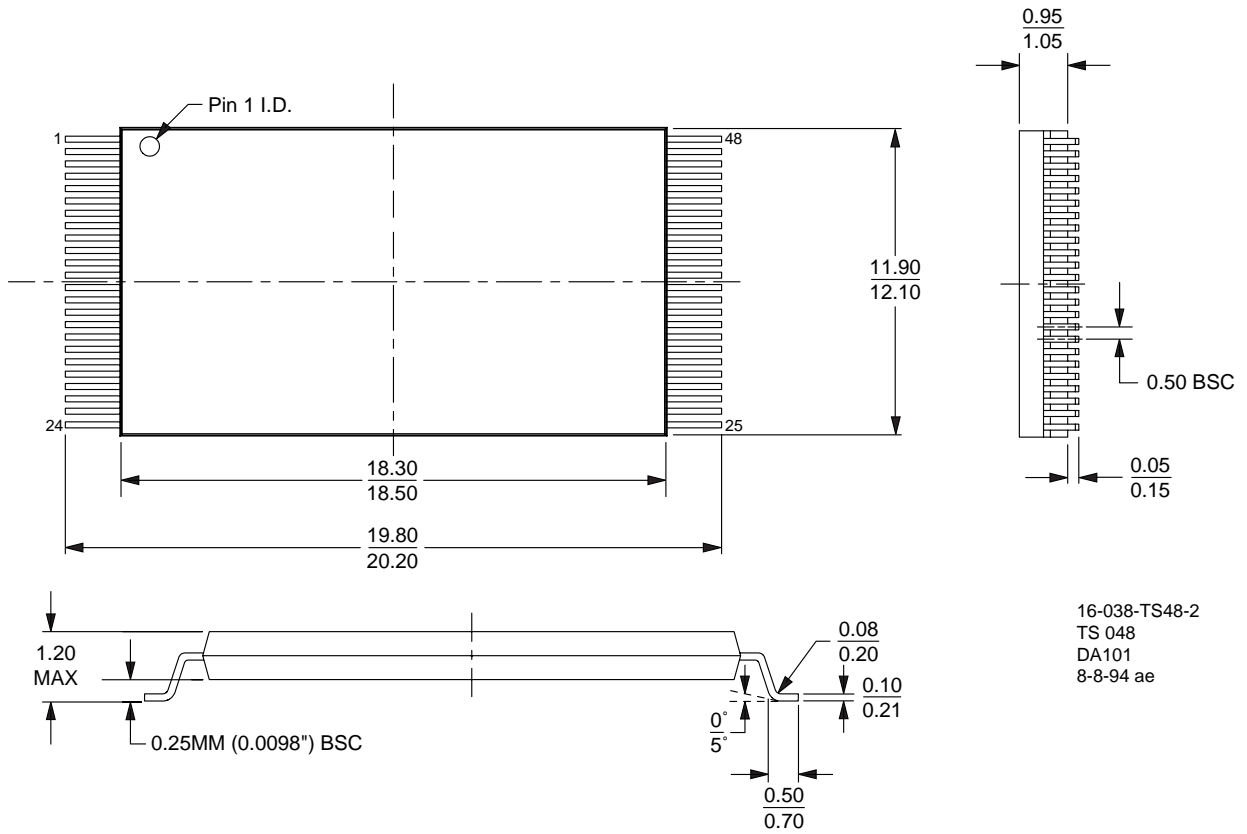

* For reference only, not drawn to scale. BSC is an ANSI standard for Basic Space Centering.

PHYSICAL DIMENSIONS (continued)

TSR048

48-Pin Reverse Standard Thin Small Outline Package (measured in millimeters)

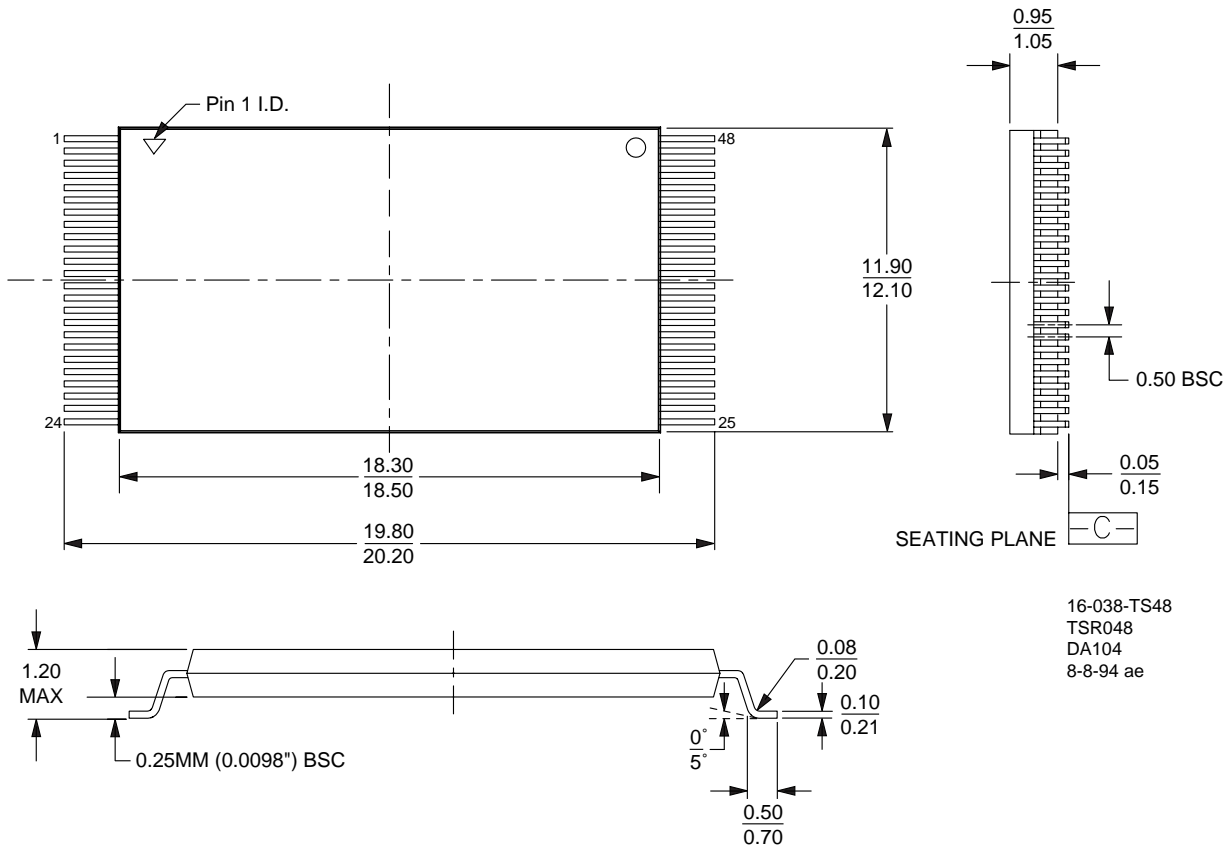

PHYSICAL DIMENSIONS (continued)

SO 044

44-Pin Thin Small Outline Package (measured in millimeters)

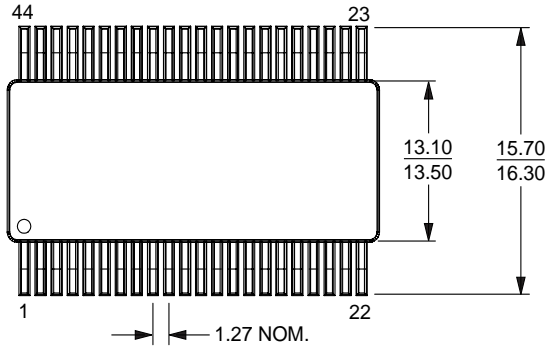

TOP VIEW

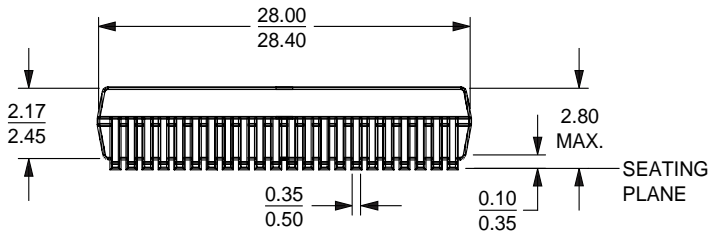

SIDE VIEW

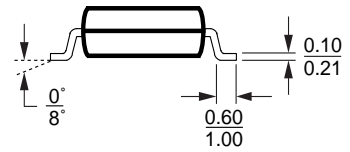

END VIEW

16-038-SO44-2
 SO 044
 DA82
 11-9-95 lv

REVISION SUMMARY FOR AM29LV800

Distinctive Characteristics:

Rearranged bullets. Renamed “Extended voltage range...” bullet to “Single power supply operation.” Under “Single power supply operation” and “High performance” bullets, defined standard and extended voltage ranges and added 90 ns speed option. Combined “Advanced power management” and “Low current consumption” bullets into new “Ultra low power consumption” bullet. Under that bullet, revised the typical standby and automatic sleep mode current specifications from 1 μ A to 200 nA; revised read current specification from 10 mA to 2 mA/MHz. Combined “Sector protection” and “Flexible sector architecture” bullets. Under flexible sector architecture bullet, added temporary sector unprotect feature description. Combined Embedded Program and Embedded Erase bullets under new “Embedded Algorithms” bullet; removed TM designations. Clarified descriptions of sector protection, erase suspend/resume, hardware reset pin, ready/busy pin, and data polling and toggle bits.

General Description:

Added text on -90R speed option and voltage range to the second paragraph.

Product Selector Guide:

Added -90R voltage range and speed option.

Connection Diagrams

Corrected pinouts on pins 13 and 14 for the standard TSOP drawing. (Revision C)

Corrected pinouts on pins 33 and 32 for the reverse TSOP drawing. (Revision C)

Corrected pinouts for pins 13, 14, 17, and 18 on standard TSOP package. (Revision D)

Pin Configuration:

Added new voltage range to V_{CC} specification.

Ordering Information, Standard Products:

The -90R speed option is now listed in the example. Revised “Speed Option” section to indicate both voltage ranges.

Valid Combinations: Added -90R speed option and voltage range.

Automatic Sleep Mode:

Revised addresses stable time to 200 ns and typical current draw to 200 nA.

Autoselect:

Fourth paragraph, last sentence: Corrected to “...DQ9 and DQ13 are equal to ‘1’...”

Table 4, Sector Address Table:

Corrected SA12, x8 starting address from D0000 to C0000.

Table 6, Command Definitions:

Grouped address designators PA, PD, RA, RD, and SA under the legend heading. Modified SA definition to accommodate the sector protect verify command. Since unlock addresses only require address bits A0–A10 to be valid, the number of hexadecimal digits in the unlock addresses were changed from four to three. The remaining upper address bits are don’t care. Removed “H” designation from hexadecimal values in table and replaced with new Note 1. Revised Notes 5 and 6 to indicate when commands are valid; are now Notes 4 and 5. Expanded autoselect section to show each function separately: manufacturer ID, device ID, and sector protect verify. Added Note 3 to explain sector protect codes. Deleted Note 7. Added Note 6 to indicate which addresses are don’t care. Corrected unlock and command addresses for byte mode from “2AA” to “AAA”. Corrected byte-mode read cycle (fourth cycle) addresses from 01h to 02h for device ID, and from SAX02 to SAX04 for sector protect verification.

RESET: Hardware Reset Pin:

Fourth paragraph: Revised standby mode specification to 200 nA.

Figure 6, Timing Diagram for Byte Mode Configuration:

Moved end of t_{FLQZ} period from within the A-1 data flow to the start of A-1 data flow.

Operating Ranges:

V_{CC} Supply Voltages: Expanded into two voltage ranges; added -90R speed option.

DC Characteristics:

CMOS Compatible: Changed I_{CC1} from 30 mA maximum at 6 MHz to 16 mA maximum at 5 MHz and 4 mA maximum at 1 MHz. Changed I_{CC2} from 35 mA to 30 mA maximum. In Note 1, changed 6 MHz to 5 MHz. In Note 3, changed address stable time from 300 ns to 200 ns; changed typical sleep mode current from 1 μ A to 200 nA.

Figure 13A, I_{CC} Current vs. Time, and Figure 13B, I_{CC} vs. Frequency:

Figure 8A illustrates current draw during the Automatic Sleep Mode after the addresses are stable. Figure 8B shows how frequency affects the current draw curves for both voltage ranges.

AC Characteristics:

Read Only Operations Characteristics: Added -90R column.

Test Conditions, Figure 13:

Added 90 ns speed to C_L note.

AC Characteristics:

Write/Erase/Program Operations: Added the -90R column. Corrected t_{WAX} to t_{WLAX} .

Figure 17, AC Waveforms for Chip/Sector Erase Operations:

Added "555 chip erase" to last cycle in sequence. Changed addresses to three hexadecimal digits to match command definitions (Table 6).

Figure 18, AC Waveforms for Data Polling During Embedded Algorithm Operations:

Split data signal into DQ0–DQ6 and DQ7 signals.

Figure 25, Temporary Sector Unprotect Timing Diagram:

Corrected callout and waveform to show that t_{VIDR} applies whether \overline{RESET} rises from either 0 V or 3 V.

AC Characteristics:

Alternate \overline{CE} Controlled Writes: Added the -90R column.

Figure 26, Alternate CE Controlled Write Operation Timings:

Changed 5555H to 555H match command definitions (Table 6).

Erase and Programming Performance:

Added typical chip erase specification. Deleted column for minimum specifications. Created separate chip program specifications for word and byte modes. Renamed erase/program cycles specification to erase/program endurance. Moved minimum 100,000 cycle endurance to comments section. Revised Note 1 to include write endurance, is now Note 2. Consolidated and moved Note 1 and Note 3 references in table to table head. Combined Note 2 and Note 5 into new Note 1, which applies to the entire table; revised to indicate that DQ5=1 after the maximum times. Comments for program and erase now straddle parameter rows. Separated the two sentences in Note 4 into new Notes 4 and 5; added corresponding note references to comment section.

Trademarks

Copyright © 1997 Advanced Micro Devices, Inc. All rights reserved.

AMD, the AMD logo, and combinations thereof and ExpressFlash are trademarks of Advanced Micro Devices, Inc.

Product names used in this publication are for identification purposes only and may be trademarks of their respective companies.

This datasheet has been downloaded from:

www.DatasheetCatalog.com

Datasheets for electronic components.



LittleDiode supplies new, hard to find or obsolete electronic components and semiconductors all over the world.

With over two million different components listed you are sure to find the part you need.

Feel free to visit us today at our online store:

LittleDiode.com

Looking forward to providing you with the best possible service.