

# Am29PLI60C

Data Sheet



July 2003

The following document specifies Spansion memory products that are now offered by both Advanced Micro Devices and Fujitsu. Although the document is marked with the name of the company that originally developed the specification, these products will be offered to customers of both AMD and Fujitsu.

## **Continuity of Specifications**

There is no change to this datasheet as a result of offering the device as a Spansion product. Any changes that have been made are the result of normal datasheet improvement and are noted in the document revision summary, where supported. Future routine revisions will occur when appropriate, and changes will be noted in a revision summary.

## **Continuity of Ordering Part Numbers**

AMD and Fujitsu continue to support existing part numbers beginning with "Am" and "MBM". To order these products, please use only the Ordering Part Numbers listed in this document.

## **For More Information**

Please contact your local AMD or Fujitsu sales office for additional information about Spansion memory solutions.

Publication Number **22143** Revision **C** Amendment **+4** Issue Date **June 12, 2002**





# Am29PL160C

16 Megabit (2 M x 8-Bit/1 M x 16-Bit)

CMOS 3.0 Volt-only High Performance Page Mode Flash Memory

## DISTINCTIVE CHARACTERISTICS

### ■ 16 Mbit Page Mode device

- Byte (8-bit) or word (16-bit) mode selectable via BYTE# pin
- Page size of 16 bytes/8 words: Fast page read access from random locations within the page

### ■ Single power supply operation

- Full voltage range: 2.7 to 3.6 volt read and write operations for battery-powered applications
- Regulated voltage range: 3.0 to 3.6 volt read and write operations and for compatibility with high performance 3.3 volt microprocessors

### ■ 5 V-tolerant data, address, and control signals

### ■ High performance read access times

- Page access times as fast as 25 ns at industrial temperature range
- Random access times as fast as 65 ns

### ■ Power consumption (typical values at 5 MHz)

- 30 mA read current
- 20 mA program/erase current
- 1  $\mu$ A standby mode current
- 1  $\mu$ A Automatic Sleep mode current

### ■ Flexible sector architecture

- Sector sizes: One 16 Kbyte, two 8 Kbyte, one 224 Kbyte, and seven sectors of 256 Kbytes each
- Supports full chip erase

### ■ Bottom boot block configuration only

### ■ Sector Protection

- A hardware method of locking a sector to prevent any program or erase operations within that sector
- Sectors can be locked via programming equipment
- Temporary Sector Unprotect command sequence allows code changes in previously locked sectors

### ■ Minimum 1 million write cycles guarantee per sector

### ■ 20-year data retention

### ■ Manufactured on 0.32 $\mu$ m process technology

### ■ Software command-set compatible with JEDEC standard

- Backward compatible with Am29F and Am29LV families

### ■ CFI (Common Flash Interface) compliant

- Provides device-specific information to the system, allowing host software to easily reconfigure for different Flash devices

### ■ Unlock Bypass Program Command

- Reduces overall programming time when issuing multiple program command sequences

### ■ Erase Suspend/Erase Resume

- Suspends an erase operation to read data from, or program data to, a sector that is not being erased, then resumes the erase operation

### ■ Package Options

- 44-pin SO (mask-ROM compatible pinout)
- 48-pin TSOP

## GENERAL DESCRIPTION

The Am29PL160C is a 16 Mbit, 3.0 Volt-only Page mode Flash memory device organized as 2,097,152 bytes or 1,048,576 words. The device is offered in a 44-pin SO or a 48-pin TSOP package. The word-wide data (x16) appears on DQ15–DQ0; the byte-wide (x8) data appears on DQ7–DQ0. This device can be programmed in-system or with in standard EPROM programmers. A 12.0 V  $V_{PP}$  or 5.0 V  $V_{CC}$  are not required for write or erase operations.

The device offers access times of 65, 70, 90, and 120 ns, allowing high speed microprocessors to operate without wait states. To eliminate bus contention the device has separate chip enable (CE#), write enable (WE#), and output enable (OE#) controls.

The sector sizes are as follows: one 16 Kbyte, two 8 Kbyte, one 224 Kbyte and seven sectors of 256 Kbytes each. The device is available in both top and bottom boot versions.

### Page Mode Features

The device is AC timing, pinout, and package **compatible with 16 Mbit x 16 page mode Mask ROM**. The page size is 8 words or 16 bytes.

After initial page access is accomplished, the page mode operation provides fast read access speed of random locations within that page.

### Standard Flash Memory Features

The device requires only a **single 3.0 volt power supply** for both read and write functions. Internally generated and regulated voltages are provided for the program and erase operations.

The device is entirely command set compatible with the **JEDEC single-power-supply Flash standard**. Commands are written to the command register using standard microprocessor write timings. Register contents serve as input to an internal state-machine that controls the erase and programming circuitry. Write cycles also internally latch addresses and data needed for the programming and erase operations. Reading data out of the device is similar to reading from other Flash or EPROM devices.

Device programming occurs by executing the program command sequence. This initiates the **Embedded Program** algorithm—an internal algorithm that automatically times the program pulse widths and

verifies proper cell margin. The **Unlock Bypass** mode facilitates faster programming times by requiring only two write cycles to program data instead of four.

Device erasure occurs by executing the erase command sequence. This initiates the **Embedded Erase** algorithm—an internal algorithm that automatically preprograms the array (if it is not already programmed) before executing the erase operation. During erase, the device automatically times the erase pulse widths and verifies proper cell margin.

The host system can detect whether a program or erase operation is complete by reading the DQ7 (Data# Polling) and DQ6 (toggle) **status bits**. After a program or erase cycle has been completed, the device is ready to read array data or accept another command.

The **sector erase architecture** allows memory sectors to be erased and reprogrammed without affecting the data contents of other sectors. The device is fully erased when shipped from the factory.

**Hardware data protection** measures include a low  $V_{CC}$  detector that automatically inhibits write operations during power transitions. The **hardware sector protection** feature disables both program and erase operations in any combination of the sectors of memory. This can be achieved in-system or via programming equipment.

The **Erase Suspend/Erase Resume** feature enables the user to put erase on hold for any period of time to read data from, or program data to, any sector that is not selected for erasure. True background erase can thus be achieved.

The device offers two power-saving features. When addresses have been stable for a specified amount of time, the device enters the **automatic sleep mode**. The system can also place the device into the **standby mode**. Power consumption is greatly reduced in both these modes.

AMD's Flash technology combines years of Flash memory manufacturing experience to produce the highest levels of quality, reliability and cost effectiveness. The device electrically erases all bits within a sector simultaneously via Fowler-Nordheim tunneling. The data is programmed using hot electron injection.

## TABLE OF CONTENTS

<b>Product Selector Guide</b> .....	4	DQ5: Exceeded Timing Limits .....	22
<b>Block Diagram</b> .....	4	Figure 4. Toggle Bit Algorithm.....	23
<b>Connection Diagrams</b> .....	5	DQ3: Sector Erase Timer .....	23
<b>Pin Configuration</b> .....	6	Table 11. Write Operation Status .....	24
<b>Logic Symbol</b> .....	6	<b>Absolute Maximum Ratings</b> .....	<b>25</b>
<b>Ordering Information</b> .....	7	Figure 5. Maximum Negative Overshoot Waveform .....	25
<b>Device Bus Operations</b> .....	8	Figure 6. Maximum Positive Overshoot Waveform.....	25
Table 1. Am29PL160C Device Bus Operations .....	8	<b>Operating Ranges</b> .....	<b>25</b>
Word/Byte Configuration .....	8	<b>DC Characteristics</b> .....	<b>26</b>
Requirements for Reading Array Data .....	8	Figure 7. I <sub>CC1</sub> Current vs. Time (Showing Active and Automatic Sleep Currents).....	27
Read Mode .....	8	Figure 8. Typical I <sub>CC1</sub> vs. Frequency .....	27
Random Read (Non-Page Mode Read) .....	8	<b>Test Conditions</b> .....	<b>28</b>
Page Mode Read .....	9	Figure 9. Test Setup.....	28
Table 2. Word Mode .....	9	Table 12. Test Specifications .....	28
Table 3. Byte Mode .....	9	<b>Key to Switching Waveforms</b> .....	<b>28</b>
Writing Commands/Command Sequences .....	10	Figure 10. Input Waveforms and Measurement Levels .....	28
Program and Erase Operation Status .....	10	<b>AC Characteristics</b> .....	<b>29</b>
Standby Mode .....	10	Figure 11. Conventional Read Operations Timings .....	30
Automatic Sleep Mode .....	10	Figure 12. Page Read Timings .....	30
Output Disable Mode .....	10	Figure 13. BYTE# Timings for Read Operations.....	31
Table 4. Sector Address Table, Bottom Boot (Am29PL160CB) .....	11	Figure 14. BYTE# Timings for Write Operations.....	31
Autoselect Mode .....	12	Figure 15. Program Operation Timings.....	33
Table 5. Am29PL160C Autoselect Codes (High Voltage Method) ..	12	Figure 16. AC Waveforms for Chip/Sector Erase Operations.....	34
Sector Protection/Unprotection .....	12	Figure 17. Data# Polling Timings (During Embedded Algorithms). 34	
<b>Common Flash Memory Interface (CFI)</b> .....	<b>13</b>	Figure 18. Toggle Bit Timings (During Embedded Algorithms).....	35
Table 6. CFI Query Identification String .....	13	Figure 19. DQ2 vs. DQ6 for Erase and Erase Suspend Operations .....	35
Table 7. System Interface String .....	14	Figure 20. Alternate CE# Controlled Write Operation Timings .....	37
Table 8. Device Geometry Definition .....	14	<b>Erase and Programming Performance</b> .....	<b>38</b>
Table 9. Primary Vendor-Specific Extended Query .....	15	<b>Latchup Characteristics</b> .....	<b>38</b>
<b>Hardware Data Protection</b> .....	<b>15</b>	<b>TSOP and SO Pin Capacitance</b> .....	<b>38</b>
Low V <sub>CC</sub> Write Inhibit .....	15	<b>Data Retention</b> .....	<b>38</b>
Write Pulse “Glitch” Protection .....	15	<b>Physical Dimensions</b> .....	<b>39</b>
Logical Inhibit .....	15	TS 048—48-Pin Standard Thin Small Outline Package .....	39
Power-Up Write Inhibit .....	15	SO 044—44-Pin Small Outline Package, Standard Pinout ....	40
<b>Command Definitions</b> .....	<b>16</b>	SOR044—44-Pin Small Outline Package, Reverse Pinout ....	41
Reading Array Data .....	16	<b>Revision Summary</b> .....	<b>42</b>
Reset Command .....	16	Revision A (August 1998) .....	42
Autoselect Command Sequence .....	16	Revision A+1 (September 1998) .....	42
Word/Byte Program Command Sequence .....	16	Revision B (January 1999) .....	42
Unlock Bypass Command Sequence .....	17	Revision B+1 (February 1999) .....	42
Figure 1. Program Operation .....	17	Revision B+2 (March 5, 1999) .....	42
Chip Erase Command Sequence .....	17	Revision B+3 (May 14, 1999) .....	42
Sector Erase Command Sequence .....	18	Revision B+4 (June 25, 1999) .....	42
Erase Suspend/Erase Resume Commands .....	18	Revision B+5 (July 26, 1999) .....	42
Temporary Unprotect Enable/Disable Command Sequence ..	19	Revision B+6 (September 2, 1999) .....	42
Figure 2. Erase Operation.....	19	Revision B+7 (February 4, 2000) .....	42
Command Definitions .....	20	Revision C (February 21, 2000) .....	42
Table 10. Am29PL160C Command Definitions .....	20	Revision C+1 (June 20, 2000) .....	42
<b>Write Operation Status</b> .....	<b>21</b>	Revision C+2 (June 28, 2000) .....	42
DQ7: Data# Polling .....	21	Revision C+3 (November 14, 2000) .....	42
Figure 3. Data# Polling Algorithm .....	21	Revision C+4 (June 12, 2002) .....	42
DQ6: Toggle Bit .....	22		
DQ2: Toggle Bit .....	22		
Reading Toggle Bits DQ6/DQ2 .....	22		

## PRODUCT SELECTOR GUIDE

Family Part Number		Am29PL160C			
Speed Option	Regulated Voltage Range: $V_{CC} = 3.0\text{--}3.6\text{ V}$	-65R	-70R		
	Full Voltage Range: $V_{CC} = 2.7\text{--}3.6\text{ V}$			-90	-120
Max access time, ns ( $t_{ACC}$ )		65	70	90	120
Max CE# access time, ns ( $t_{CE}$ )		65	70	90	120
Max page access time, ns ( $t_{PACC}$ )		25	25	30	30
Max OE# access time, ns ( $t_{OE}$ )		25	25	30	30

**Note:** See "AC Characteristics" for full specifications.

## BLOCK DIAGRAM

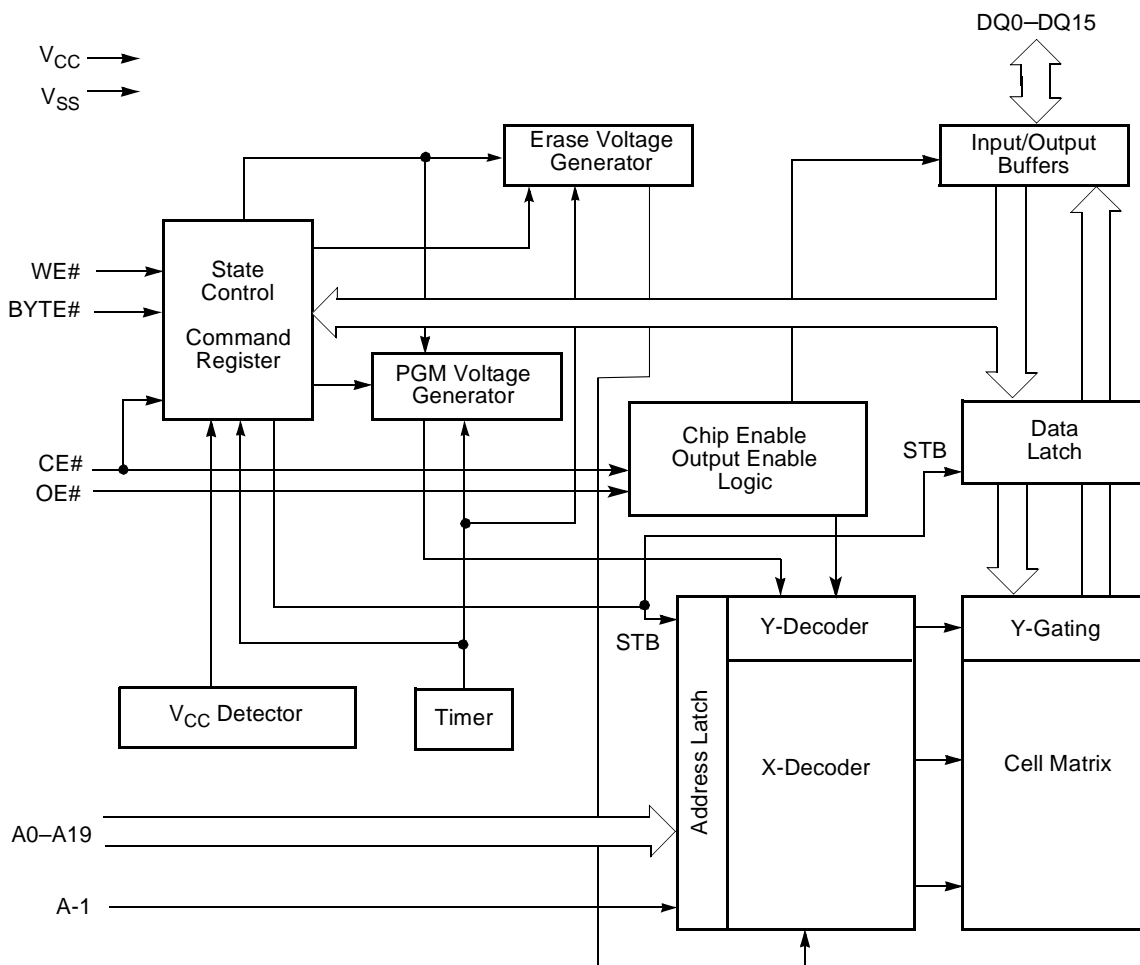

CONNECTION DIAGRAMS

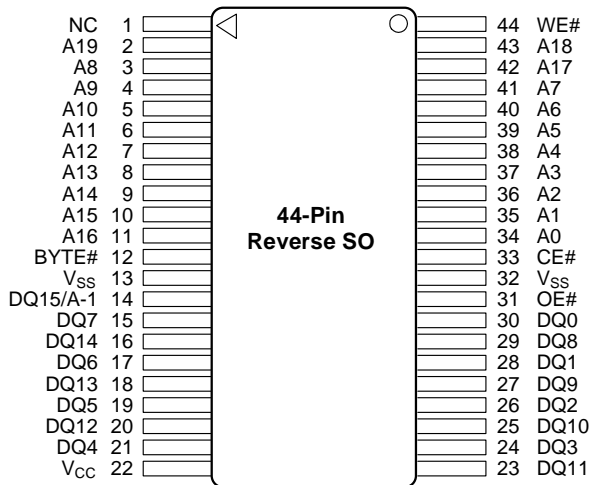
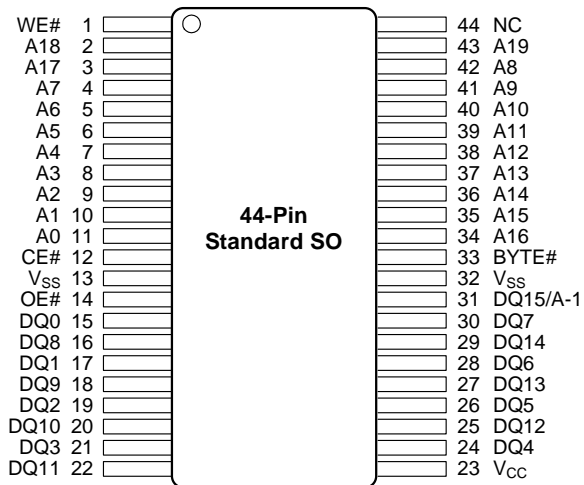
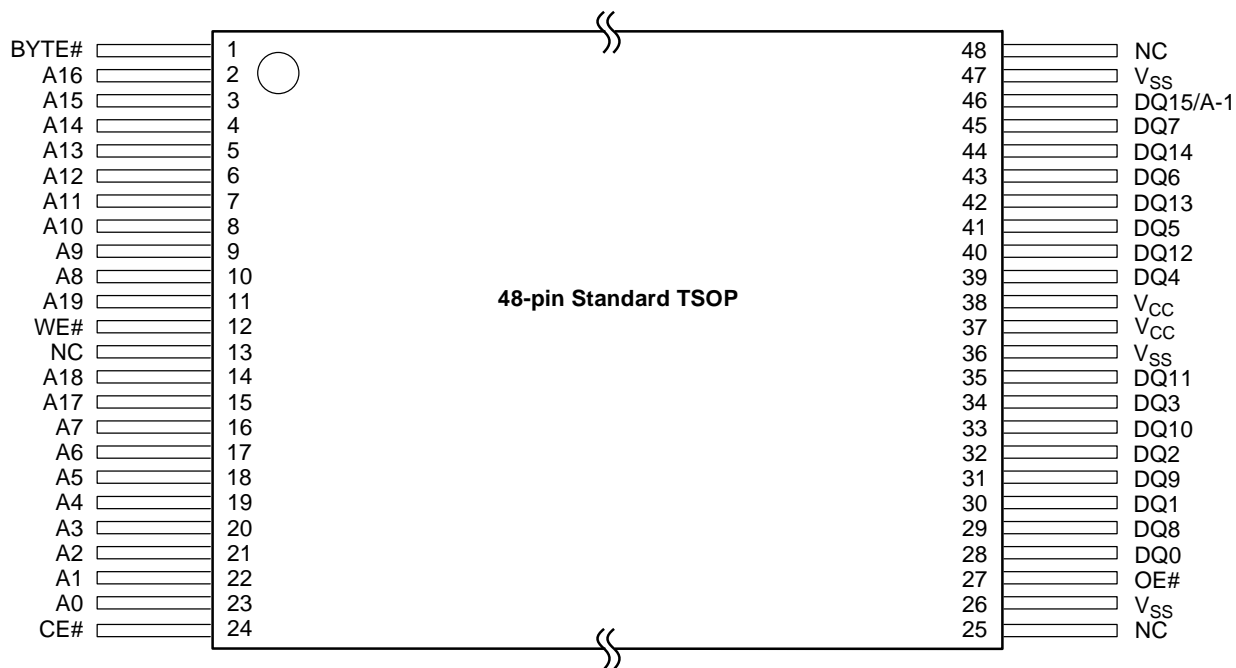

## PIN CONFIGURATION

A0–A19	=	20 address inputs
DQ0–DQ15	=	16 data inputs/outputs
DQ15/A-1	=	In word mode, functions as DQ15 (MSB data input/output) In byte mode, functions as A-1 (LSB address input)
BYTE#	=	Byte enable input When low, enables byte mode When high, enables word mode
CE#	=	Chip Enable input
OE#	=	Output Enable input
WE#	=	Write Enable input
V <sub>CC</sub>	=	3.0 volt-only single power supply (see Product Selector Guide for speed options and voltage supply tolerances)
V <sub>SS</sub>	=	Device ground
NC	=	Pin not connected internally

## LOGIC SYMBOL

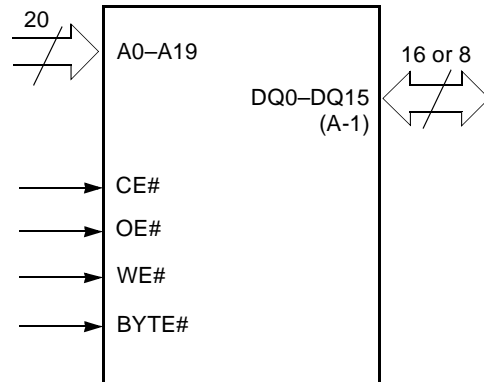

## ORDERING INFORMATION

### Standard Products

AMD standard products are available in several packages and operating ranges. The order number (Valid Combination) is formed by a combination of the elements below.

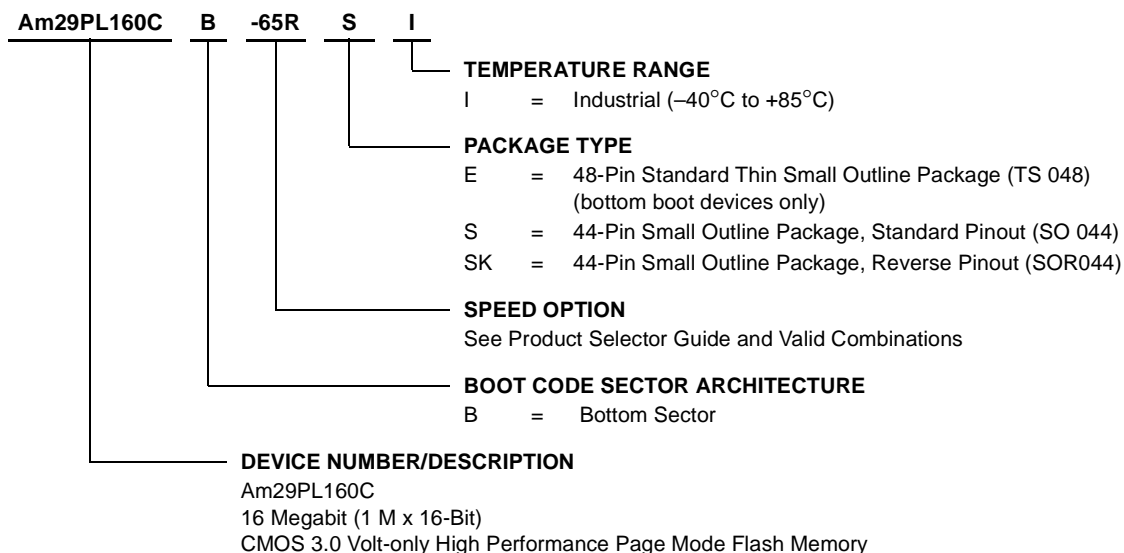

Valid Combinations (Bottom Boot)		Voltage Range
AM29PL160CB-65R	EI, SI, SKI	$V_{CC} = 3.0\text{--}3.6\text{ V}$
AM29PL160CB-70R		
AM29PL160CB-90		$V_{CC} = 2.7\text{--}3.6\text{ V}$
AM29PL160CB-120		

#### Valid Combinations

Valid Combinations list configurations planned to be supported in volume for this device. Consult the local AMD sales office to confirm availability of specific valid combinations and to check on newly released combinations.

## DEVICE BUS OPERATIONS

This section describes the requirements and use of the device bus operations, which are initiated through the internal command register. The command register itself does not occupy any addressable memory location. The register is composed of latches that store the commands, along with the address and data information needed to execute the command. The contents

of the register serve as inputs to the internal state machine. The state machine outputs dictate the function of the device. Table 1 lists the device bus operations, the inputs and control levels they require, and the resulting output. The following subsections describe each of these operations in further detail.

**Table 1. Am29PL160C Device Bus Operations**

Operation	CE#	OE#	WE#	Addresses (Note 1)	DQ0– DQ7	DQ8–DQ15	
						BYTE# = V <sub>IH</sub>	BYTE# = V <sub>IL</sub>
Read	L	L	H	A <sub>IN</sub>	D <sub>OUT</sub>	D <sub>OUT</sub>	DQ8–DQ14 = High-Z, DQ15 = A-1
Write	L	H	L	A <sub>IN</sub>	D <sub>IN</sub>	D <sub>IN</sub>	
Standby	V <sub>CC</sub> ± 0.3 V	X	X	X	High-Z	High-Z	High-Z
Output Disable	L	H	H	X	High-Z	High-Z	High-Z

**Legend:**

L = Logic Low = V<sub>IL</sub>, H = Logic High = V<sub>IH</sub>, V<sub>ID</sub> = 12.0 ± 0.5 V, X = Don't Care, A<sub>IN</sub> = Address In, D<sub>IN</sub> = Data In, D<sub>OUT</sub> = Data Out

**Notes:**

- Addresses are A19:A0 in word mode (BYTE# = V<sub>IH</sub>), A19:A-1 in byte mode (BYTE# = V<sub>IL</sub>).
- The sector protect and sector unprotect functions must be implemented via programming equipment. See the "Sector Protection/Unprotection" section.

### Word/Byte Configuration

The BYTE# pin controls whether the device data I/O pins DQ15–DQ0 operate in the byte or word configuration. If the BYTE# pin is set at logic '1', the device is in word configuration, DQ15–DQ0 are active and controlled by CE# and OE#.

If the BYTE# pin is set at logic '0', the device is in byte configuration, and only data I/O pins DQ0–DQ7 are active and controlled by CE# and OE#. The data I/O pins DQ8–DQ14 are tri-stated, and the DQ15 pin is used as an input for the LSB (A-1) address function.

### Requirements for Reading Array Data

To read array data from the outputs, the system must drive the CE# and OE# pins to V<sub>IL</sub>. CE# is the power control and selects the device. OE# is the output control and gates array data to the output pins. WE# should remain at V<sub>IH</sub>. The BYTE# pin determines whether the device outputs array data in words or bytes.

The internal state machine is set for reading array data upon device power-up, or after a reset command (when not executing a program or erase operation). This ensures that no spurious alteration of the memory content occurs during the power transition. No command is necessary in this mode to obtain array data.

Standard microprocessor read cycles that assert valid addresses on the device address inputs produce valid data on the device data outputs. The device remains enabled for read access until the command register contents are altered.

See "Reading Array Data" for more information. Refer to the AC Read Operations table for timing specifications and to Figure 11 for the timing diagram. I<sub>CC1</sub> in the DC Characteristics table represents the active current specification for reading array data.

### Read Mode

#### Random Read (Non-Page Mode Read)

The device has two control functions which must be satisfied in order to obtain data at the outputs. CE# is the power control and should be used for device selection. OE# is the output control and should be used to gate data to the output pins if the device is selected.

Address access time (t<sub>ACC</sub>) is equal to the delay from stable addresses to valid output data. The chip enable access time (t<sub>CE</sub>) is the delay from the stable addresses and stable CE# to valid data at the output pins. The output enable access time is the delay from the falling edge of OE# to valid data at the output pins (assuming the addresses have been stable for at least t<sub>ACC</sub>–t<sub>OE</sub> time).

## Page Mode Read

The Am29PL160C is capable of fast Page mode read and is compatible with the Page mode Mask ROM read operation. This mode provides faster read access speed for random locations within a page. The Page size of the Am29PL160C device is 8 words, or 16 bytes, with the appropriate Page being selected by the higher address bits A3–A19 and the LSB bits A0–A2 (in the word mode) and A-1 to A2 (in the byte mode) determining the specific word/byte within that page. This is an asynchronous operation with the microprocessor supplying the specific word or byte location.

The random or initial page access is equal to  $t_{ACC}$  or  $t_{CE}$  and subsequent Page read accesses (as long as the locations specified by the microprocessor falls within that Page) is equivalent to  $t_{PACC}$ . When CE# is deasserted and reasserted for a subsequent access, the access time is  $t_{ACC}$  or  $t_{CE}$ . Here again, CE# selects the device and OE# is the output control and should be used to gate data to the output pins if the device is selected. Fast Page mode accesses are obtained by keeping A3–A19 constant and changing A0 to A2 to select the specific word, or changing A-1 to A2 to select the specific byte, within that page.

The following tables determine the specific word and byte within the selected page:

**Table 2. Word Mode**

Word	A2	A1	A0
Word 0	0	0	0
Word 1	0	0	1
Word 2	0	1	0
Word 3	0	1	1
Word 4	1	0	0
Word 5	1	0	1
Word 6	1	1	0
Word 7	1	1	1

**Table 3. Byte Mode**

Byte	A2	A1	A0	A-1
Byte 0	0	0	0	0
Byte 1	0	0	0	1
Byte 2	0	0	1	0
Byte 3	0	0	1	1
Byte 4	0	1	0	0
Byte 5	0	1	0	1
Byte 6	0	1	1	0
Byte 7	0	1	1	1
Byte 8	1	0	0	0
Byte 9	1	0	0	1
Byte 10	1	0	1	0
Byte 11	1	0	1	1
Byte 12	1	1	0	0
Byte 13	1	1	0	1
Byte 14	1	1	1	0
Byte 15	1	1	1	1

## Writing Commands/Command Sequences

To write a command or command sequence (which includes programming data to the device and erasing sectors of memory), the system must drive WE# and CE# to  $V_{IL}$ , and OE# to  $V_{IH}$ .

For program operations, the BYTE# pin determines whether the device accepts program data in bytes or words. Refer to “Word/Byte Configuration” for more information.

The device features an **Unlock Bypass** mode to facilitate faster programming. Once the device enters the Unlock Bypass mode, only two write cycles are required to program a word or byte, instead of four. The “Word/Byte Program Command Sequence” section has details on programming data to the device using both standard and Unlock Bypass command sequences.

An erase operation can erase one sector, multiple sectors, or the entire device. Table 4 indicates the address space that each sector occupies. A “sector address” consists of the address bits required to uniquely select a sector. The “Command Definitions” section has details on erasing a sector or the entire chip, or suspending/resuming the erase operation.

After the system writes the autoselect command sequence, the device enters the autoselect mode. The system can then read autoselect codes from the internal register (which is separate from the memory array) on DQ7–DQ0. Standard read cycle timings apply in this mode. Refer to the “Autoselect Mode” and “Autoselect Command Sequence” sections for more information.

$I_{CC2}$  in the DC Characteristics table represents the active current specification for the write mode. The “AC Characteristics” section contains timing specification tables and timing diagrams for write operations.

## Program and Erase Operation Status

During an erase or program operation, the system may check the status of the operation by reading the status

bits on DQ7–DQ0. Standard read cycle timings and  $I_{CC}$  read specifications apply. Refer to “Write Operation Status” for more information, and to “AC Characteristics” for timing diagrams.

## Standby Mode

When the system is not reading or writing to the device, it can place the device in the standby mode. In this mode, current consumption is greatly reduced, and the outputs are placed in the high impedance state, independent of the OE# input.

The device enters the CMOS standby mode when the CE# pin is both held at  $V_{CC} \pm 0.3$  V. (Note that this is a more restricted voltage range than  $V_{IH}$ .) If CE# is held at  $V_{IH}$ , but not within  $V_{CC} \pm 0.3$  V, the device will be in the standby mode, but the standby current will be greater. The device requires standard access time ( $t_{CE}$ ) for read access when the device is in either of these standby modes, before it is ready to read data.

If the device is deselected during erasure or programming, the device draws active current until the operation is completed.

## Automatic Sleep Mode

The automatic sleep mode minimizes Flash device energy consumption. The device automatically enables this mode when addresses remain stable for  $t_{ACC} + 30$  ns. The automatic sleep mode is independent of the CE#, WE#, and OE# control signals. Standard address access timings provide new data when addresses are changed. While in sleep mode, output data is latched and always available to the system. Note that during Automatic Sleep mode, OE# must be at  $V_{IH}$  before the device reduces current to the stated sleep mode specification.

## Output Disable Mode

When the OE# input is at  $V_{IH}$ , output from the device is disabled. The output pins are placed in the high impedance state.

Table 4. Sector Address Table, Bottom Boot (Am29PL160CB)

Sector	A19	A18	A17	A16	A15	A14	A13	A12	Sector Size (Kbytes/ Kwords)	Address Range (in hexadecimal)	
										Byte Mode (x8)	Word Mode (x16)
SA0	0	0	0	0	0	0	0	X	16/8	000000–003FFF	00000–01FFF
SA1	0	0	0	0	0	0	1	0	8/4	004000–005FFF	02000–02FFF
SA2	0	0	0	0	0	0	1	1	8/4	006000–007FFF	03000–03FFF
SA3	0	0	0		01000–11111				224/112	008000–03FFFF	04000–1FFFF
SA4	0	0	1	X	X	X	X	X	256/128	040000–07FFFF	20000–3FFFF
SA5	0	1	0	X	X	X	X	X	256/128	080000–0BFFFF	40000–5FFFF
SA6	0	1	1	X	X	X	X	X	256/128	0C0000–0FFFFF	60000–7FFFF
SA7	1	0	0	X	X	X	X	X	256/128	100000–13FFFF	80000–9FFFF
SA8	1	0	1	X	X	X	X	X	256/128	140000–17FFFF	A0000–BFFFF
SA9	1	1	0	X	X	X	X	X	256/128	180000–1BFFFF	C0000–DFFFF
SA10	1	1	1	X	X	X	X	X	256/128	1C0000–1FFFFF	E0000–FFFFF

## Autoselect Mode

The autoselect mode provides manufacturer and device identification, and sector protection verification, through identifier codes output on DQ7–DQ0. This mode is primarily intended for programming equipment to automatically match a device to be programmed with its corresponding programming algorithm. However, the autoselect codes can also be accessed in-system through the command register.

When using programming equipment, the autoselect mode requires  $V_{ID}$  (11.5 V to 12.5 V) on address pin A9. Address pins A6, A1, and A0 must be as shown in

Table 5. In addition, when verifying sector protection, the sector address must appear on the appropriate highest order address bits (Table 4). Table 5 shows the remaining address bits that are don't care. When all necessary bits have been set as required, the programming equipment may then read the corresponding identifier code on DQ7-DQ0.

To access the autoselect codes in-system, the host system can issue the autoselect command via the command register, as shown in Table 10. This method does not require  $V_{ID}$ . See "Command Definitions" for details on using the autoselect mode.

**Table 5. Am29PL160C Autoselect Codes (High Voltage Method)**

Description	Mode	CE#	OE#	WE#	A19 to A12	A11 to A10	A9	A8 to A7	A6	A5 to A2	A1	A0	DQ8 to DQ15	DQ7 to DQ0
Manufacturer ID: AMD		L	L	H	X	X	$V_{ID}$	X	L	X	L	L	X	01h
Device ID: Am29PL160C (Bottom Boot Block)	Word	L	L	H	X	X	$V_{ID}$	X	L	X	L	H	22h	45h
	Byte	L	L	H									X	45h
Sector Protection Verification		L	L	H	SA	X	$V_{ID}$	X	L	X	H	L	X	01h (protected)
													X	00h (unprotected)

$L = \text{Logic Low} = V_{IL}$ ,  $H = \text{Logic High} = V_{IH}$ , SA = Sector Address, X = Don't care.

**Note:** The autoselect codes may also be accessed in-system via command sequences. See Table 10.

## Sector Protection/Unprotection

The hardware sector protection feature disables both program and erase operations in any sector. The hardware sector unprotection feature re-enables both program and erase operations in previously protected sectors.

The device is shipped with all sectors unprotected. AMD offers the option of programming and protecting sectors at its factory prior to shipping the device through AMD's ExpressFlash™ Service. Contact an AMD representative for details.

It is possible to determine whether a sector is protected or unprotected. See "Autoselect Mode" for details.

Sector protection and unprotection must be implemented using programming equipment. The procedure requires  $V_{ID}$  on address pin A9 and OE#. Details on this method are provided in a supplement, publication number 22239. Contact an AMD representative to request a copy.

The device features a temporary unprotect command sequence to allow changing array data in-system. See "Temporary Unprotect Enable/Disable Command Sequence" for more information.

## COMMON FLASH MEMORY INTERFACE (CFI)

The Common Flash Interface (CFI) specification outlines device and host system software interrogation handshake, which allows specific vendor-specified software algorithms to be used for entire families of devices. Software support can then be device-independent, JEDEC ID-independent, and forward- and backward-compatible for the specified flash device families. Flash vendors can standardize their existing interfaces for long-term compatibility.

This device enters the CFI Query mode when the system writes the CFI Query command, 98h, to address 55h in word mode (or address AAh in byte mode), any time the device is ready to read array data. The system

can read CFI information at the addresses given in Tables 6–9. To terminate reading CFI data, the system must write the reset command.

The system can also write the CFI query command when the device is in the autoselect mode. The device enters the CFI query mode, and the system can read CFI data at the addresses given in Tables 6–9. The system must write the reset command to return the device to the autoselect mode.

For further information, please refer to the CFI Specification and CFI Publication 100, available via the World Wide Web at <http://www.amd.com/products/nvd/overview/cfi.html>. Alternatively, contact an AMD representative for copies of these documents.

**Table 6. CFI Query Identification String**

Addresses (Word Mode)	Addresses (Byte Mode)	Data	Description
10h 11h 12h	20h 22h 24h	0051h 0052h 0059h	Query Unique ASCII string "QRY"
13h 14h	26h 28h	0002h 0000h	Primary OEM Command Set
15h 16h	2Ah 2Ch	0040h 0000h	Address for Primary Extended Table
17h 18h	2Eh 30h	0000h 0000h	Alternate OEM Command Set (00h = none exists)
19h 1Ah	32h 34h	0000h 0000h	Address for Alternate OEM Extended Table (00h = none exists)

**Table 7. System Interface String**

Addresses (Word Mode)	Addresses (Byte Mode)	Data	Description
1Bh	36h	0027h	V <sub>CC</sub> Min. (write/erase) D7–D4: volt, D3–D0: 100 millivolt
1Ch	38h	0036h	V <sub>CC</sub> Max. (write/erase), D7–D4: volt, D3–D0: 100 millivolt
1Dh	3Ah	0000h	V <sub>PP</sub> Min. voltage (00h = no V <sub>PP</sub> pin present)
1Eh	3Ch	0000h	V <sub>PP</sub> Max. voltage (00h = no V <sub>PP</sub> pin present)
1Fh	3Eh	0004h	Typical timeout per single byte/word write 2 <sup>N</sup> μs
20h	40h	0000h	Typical timeout for Min. size buffer write 2 <sup>N</sup> μs (00h = not supported)
21h	42h	000Ah	Typical timeout per individual block erase 2 <sup>N</sup> ms
22h	44h	0000h	Typical timeout for full chip erase 2 <sup>N</sup> ms (00h = not supported)
23h	46h	0005h	Max. timeout for byte/word write 2 <sup>N</sup> times typical
24h	48h	0000h	Max. timeout for buffer write 2 <sup>N</sup> times typical
25h	4Ah	0004h	Max. timeout per individual block erase 2 <sup>N</sup> times typical
26h	4Ch	0000h	Max. timeout for full chip erase 2 <sup>N</sup> times typical (00h = not supported)

**Table 8. Device Geometry Definition**

Addresses (Word Mode)	Addresses (Byte Mode)	Data	Description
27h	4Eh	0015h	Device Size = 2 <sup>N</sup> byte
28h 29h	50h 52h	0002h 0000h	Flash Device Interface description (refer to CFI publication 100)
2Ah 2Bh	54h 56h	0000h 0000h	Max. number of bytes in multi-byte write = 2 <sup>N</sup> (00h = not supported)
2Ch	58h	0004h	Number of Erase Block Regions within device
2Dh 2Eh 2Fh 30h	5Ah 5Ch 5Eh 60h	0000h 0000h 0040h 0000h	Erase Block Region 1 Information (refer to the CFI specification or CFI publication 100)
31h 32h 33h 34h	62h 64h 66h 68h	0001h 0000h 0020h 0000h	Erase Block Region 2 Information
35h 36h 37h 38h	6Ah 6Ch 6Eh 70h	0000h 0000h 0080h 0003h	Erase Block Region 3 Information
39h 3Ah 3Bh 3Ch	72h 74h 76h 78h	0006h 0000h 0000h 0004h	Erase Block Region 4 Information

Table 9. Primary Vendor-Specific Extended Query

Addresses (Word Mode)	Addresses (Byte Mode)	Data	Description
40h 41h 42h	80h 82h 84h	0050h 0052h 0049h	Query-unique ASCII string "PRI"
43h	86h	0031h	Major version number, ASCII
44h	88h	0030h	Minor version number, ASCII
45h	8Ah	0000h	Address Sensitive Unlock 0 = Required, 1 = Not Required
46h	8Ch	0002h	Erase Suspend 0 = Not Supported, 1 = To Read Only, 2 = To Read & Write
47h	8Eh	0001h	Sector Protect 0 = Not Supported, X = Number of sectors in per group
48h	90h	0001h	Sector Temporary Unprotect 00 = Not Supported, 01 = Supported
49h	92h	0004h	Sector Protect/Unprotect scheme 01 = 29F040 mode, 02 = 29F016 mode, 03 = 29F400 mode, 04 = 29LV800A mode
4Ah	94h	0000h	Simultaneous Operation 00 = Not Supported, 01 = Supported
4Bh	96h	0000h	Burst Mode Type 00 = Not Supported, 01 = 4 Word Linear Burst, 02 = 8 Word Linear Burst, 03 = 32 Linear Burst, 04 = 4 Word Interleave Burst
4Ch	98h	0002h	Page Mode Type 00 = Not Supported, 01 = 4 Word Page, 02 = 8 Word Page

## HARDWARE DATA PROTECTION

The command sequence requirement of unlock cycles for programming or erasing provides data protection against inadvertent writes (refer to Table 10 for command definitions). In addition, the following hardware data protection measures prevent accidental erasure or programming, which might otherwise be caused by spurious system level signals during  $V_{CC}$  power-up and power-down transitions, or from system noise.

### Low $V_{CC}$ Write Inhibit

When  $V_{CC}$  is less than  $V_{LKO}$ , the device does not accept any write cycles. This protects data during  $V_{CC}$  power-up and power-down. The command register and all internal program/erase circuits are disabled, and the device resets. Subsequent writes are ignored until  $V_{CC}$  is greater than  $V_{LKO}$ . The system must pro-

vide the proper signals to the control pins to prevent unintentional writes when  $V_{CC}$  is greater than  $V_{LKO}$ .

### Write Pulse "Glitch" Protection

Noise pulses of less than 5 ns (typical) on OE#, CE# or WE# do not initiate a write cycle.

### Logical Inhibit

Write cycles are inhibited by holding any one of OE# =  $V_{IL}$ , CE# =  $V_{IH}$  or WE# =  $V_{IH}$ . To initiate a write cycle, CE# and WE# must be a logical zero while OE# is a logical one.

### Power-Up Write Inhibit

If WE# = CE# =  $V_{IL}$  and OE# =  $V_{IH}$  during power up, the device does not accept commands on the rising edge of WE#. The internal state machine is automatically reset to reading array data on power-up.

## COMMAND DEFINITIONS

Writing specific address and data commands or sequences into the command register initiates device operations. Table 10 defines the valid register command sequences. Writing **incorrect address and data values** or writing them in the **improper sequence** resets the device to reading array data.

All addresses are latched on the falling edge of WE# or CE#, whichever happens later. All data is latched on the rising edge of WE# or CE#, whichever happens first. Refer to the appropriate timing diagrams in the “AC Characteristics” section.

### Reading Array Data

The device is automatically set to reading array data after device power-up. No commands are required to retrieve data. The device is also ready to read array data after completing an Embedded Program or Embedded Erase algorithm.

After the device accepts an Erase Suspend command, the device enters the Erase Suspend mode. The system can read array data using the standard read timings, except that if it reads at an address within erase-suspended sectors, the device outputs status data. After completing a programming operation in the Erase Suspend mode, the system may once again read array data with the same exception. See “Erase Suspend/Erase Resume Commands” for more information on this mode.

The system *must* issue the reset command to re-enable the device for reading array data if DQ5 goes high, or while in the autoselect mode. See the “Reset Command” section, next.

See also “Requirements for Reading Array Data” in the “Device Bus Operations” section for more information. The Read Operations table provides the read parameters, and Figure 11 shows the timing diagram.

### Reset Command

Writing the reset command to the device resets the device to reading array data. Address bits are don't care for this command.

The reset command may be written between the sequence cycles in an erase command sequence before erasing begins. This resets the device to reading array data. Once erasure begins, however, the device ignores reset commands until the operation is complete.

The reset command may be written between the sequence cycles in a program command sequence before programming begins. This resets the device to reading array data (also applies to programming in Erase Suspend mode). Once programming begins, however, the device ignores reset commands until the operation is complete.

The reset command may be written between the sequence cycles in an autoselect command sequence. Once in the autoselect mode, the reset command *must* be written to return to reading array data (also applies to autoselect during Erase Suspend).

If DQ5 goes high during a program or erase operation, writing the reset command returns the device to reading array data (also applies during Erase Suspend).

### Autoselect Command Sequence

The autoselect command sequence allows the host system to access the manufacturer and device codes, and determine whether or not a sector is protected. Table 10 shows the address and data requirements. This method is an alternative to that shown in Table 5, which is intended for PROM programmers and requires  $V_{ID}$  on address bit A9.

The autoselect command sequence is initiated by writing two unlock cycles, followed by the autoselect command. The device then enters the autoselect mode, and the system may read at any address any number of times, without initiating another command sequence.

A read cycle at address XX00h retrieves the manufacturer code. A read cycle at address XX01h returns the device code. A read cycle containing a sector address (SA) and the address 02h in word mode (or 04h in byte mode) returns 01h if that sector is protected, or 00h if it is unprotected. Refer to Table 4 for valid sector addresses.

The system must write the reset command to exit the autoselect mode and return to reading array data.

### Word/Byte Program Command Sequence

The system may program the device by word or byte, depending on the state of the BYTE# pin. Programming is a four-bus-cycle operation. The program command sequence is initiated by writing two unlock write cycles, followed by the program set-up command. The program address and data are written next, which in turn initiate the Embedded Program algorithm. The system is *not* required to provide further controls or timings. The device automatically generates the program pulses and verifies the programmed cell margin. Table 10 shows the address and data requirements for the byte program command sequence.

When the Embedded Program algorithm is complete, the device then returns to reading array data and addresses are no longer latched. The system can determine the status of the program operation by using DQ7 or DQ6. See “Write Operation Status” for information on these status bits.

Any commands written to the device during the Embedded Program Algorithm are ignored.

Programming is allowed in any sequence and across sector boundaries. **A bit cannot be programmed from a “0” back to a “1”.** Attempting to do so may halt the operation and set DQ5 to “1,” or cause the Data# Polling algorithm to indicate the operation was successful. However, a succeeding read will show that the data is still “0”. Only erase operations can convert a “0” to a “1”.

### Unlock Bypass Command Sequence

The unlock bypass feature allows the system to program bytes or words to the device faster than using the standard program command sequence. The unlock bypass command sequence is initiated by first writing two unlock cycles. This is followed by a third write cycle containing the unlock bypass command, 20h. The device then enters the unlock bypass mode. A two-cycle unlock bypass program command sequence is all that is required to program in this mode. The first cycle in this sequence contains the unlock bypass program command, A0h; the second cycle contains the program address and data. Additional data is programmed in the same manner. This mode dispenses with the initial two unlock cycles required in the standard program command sequence, resulting in faster total programming time. Table 10 shows the requirements for the command sequence.

During the unlock bypass mode, only the Unlock Bypass Program and Unlock Bypass Reset commands are valid. To exit the unlock bypass mode, the system must issue the two-cycle unlock bypass reset command sequence. The first cycle must contain the data 90h; the second cycle the data 00h. Addresses are don't care for both cycles. The device then returns to reading array data.

Figure 1 illustrates the algorithm for the program operation. See the Program/Erase Operations table in “AC Characteristics” for parameters, and to Figure 15 for timing diagrams.

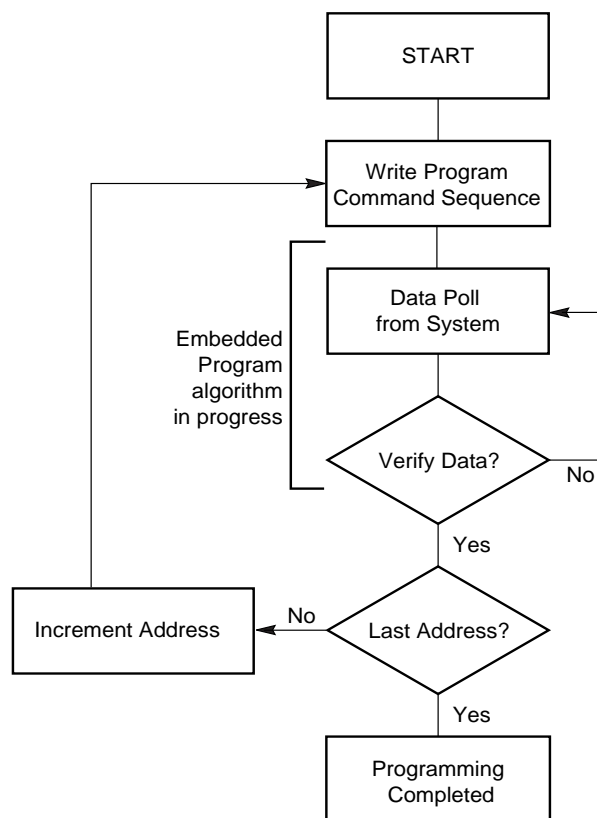

**Note:** See Table 10 for program command sequence.

**Figure 1. Program Operation**

### Chip Erase Command Sequence

Chip erase is a six bus cycle operation. The chip erase command sequence is initiated by writing two unlock cycles, followed by a set-up command. Two additional unlock write cycles are then followed by the chip erase command, which in turn invokes the Embedded Erase algorithm. The device does *not* require the system to preprogram prior to erase. The Embedded Erase algorithm automatically preprograms and verifies the entire memory for an all zero data pattern prior to electrical erase. The system is not required to provide any controls or timings during these operations. Table 10 shows the address and data requirements for the chip erase command sequence.

Any commands written to the chip during the Embedded Erase algorithm are ignored.

The system can determine the status of the erase operation by using DQ7, DQ6, or DQ2. See “Write Operation Status” for information on these status bits. When the Embedded Erase algorithm is complete, the

device returns to reading array data and addresses are no longer latched.

Figure 2 illustrates the algorithm for the erase operation. See the Program/Erase Operations tables in “AC Characteristics” for parameters, and to Figure 16 for timing diagrams.

## Sector Erase Command Sequence

Sector erase is a six bus cycle operation. The sector erase command sequence is initiated by writing two unlock cycles, followed by a set-up command. Two additional unlock write cycles are then followed by the address of the sector to be erased, and the sector erase command. Table 10 shows the address and data requirements for the sector erase command sequence.

The device does *not* require the system to preprogram the memory prior to erase. The Embedded Erase algorithm automatically programs and verifies the sector for an all zero data pattern prior to electrical erase. The system is not required to provide any controls or timings during these operations.

After the command sequence is written, a sector erase time-out of 50  $\mu$ s begins. During the time-out period, additional sector addresses and sector erase commands may be written. Loading the sector erase buffer may be done in any sequence, and the number of sectors may be from one sector to all sectors. The time between these additional cycles must be less than 50  $\mu$ s, otherwise the last address and command might not be accepted, and erasure may begin. It is recommended that processor interrupts be disabled during this time to ensure all commands are accepted. The interrupts can be re-enabled after the last Sector Erase command is written. If the time between additional sector erase commands can be assumed to be less than 50  $\mu$ s, the system need not monitor DQ3. **Any command other than Sector Erase or Erase Suspend during the time-out period resets the device to reading array data.** The system must rewrite the command sequence and any additional sector addresses and commands.

The system can monitor DQ3 to determine if the sector erase timer has timed out. (See the “DQ3: Sector Erase Timer” section.) The time-out begins from the rising edge of the final WE# pulse in the command sequence.

Once the sector erase operation has begun, only the Erase Suspend command is valid. All other commands are ignored.

When the Embedded Erase algorithm is complete, the device returns to reading array data and addresses are no longer latched. The system can determine the status of the erase operation by using DQ7, DQ6, or DQ2. (Refer to “Write Operation Status” for information on these status bits.)

Figure 2 illustrates the algorithm for the erase operation. Refer to the Program/Erase Operations tables in the “AC Characteristics” section for parameters, and to Figure 16 for timing diagrams.

## Erase Suspend/Erase Resume Commands

The Erase Suspend command allows the system to interrupt a sector erase operation and then read data from, or program data to, any sector not selected for erasure. This command is valid only during the sector erase operation, including the 50  $\mu$ s time-out period during the sector erase command sequence. The Erase Suspend command is ignored if written during the chip erase operation or Embedded Program algorithm. Writing the Erase Suspend command during the Sector Erase time-out immediately terminates the time-out period and suspends the erase operation. Addresses are “don’t-cares” when writing the Erase Suspend command.

When the Erase Suspend command is written during a sector erase operation, the device requires a maximum of 20  $\mu$ s to suspend the erase operation. However, when the Erase Suspend command is written during the sector erase time-out, the device immediately terminates the time-out period and suspends the erase operation.

After the erase operation has been suspended, the system can read array data from or program data to any sector not selected for erasure. (The device “erase suspends” all sectors selected for erasure.) Normal read and write timings and command definitions apply. Reading at any address within erase-suspended sectors produces status data on DQ7–DQ0. The system can use DQ7, or DQ6 and DQ2 together, to determine if a sector is actively erasing or is erase-suspended. See “Write Operation Status” for information on these status bits.

After an erase-suspended program operation is complete, the system can once again read array data within non-suspended sectors. The system can determine the status of the program operation using the DQ7 or DQ6 status bits, just as in the standard program operation. See “Write Operation Status” for more information.

The system may also write the autoselect command sequence when the device is in the Erase Suspend mode. The device allows reading autoselect codes even at addresses within erasing sectors, since the codes are not stored in the memory array. When the device exits the autoselect mode, the device reverts to the Erase Suspend mode, and is ready for another valid operation. See “Autoselect Command Sequence” for more information.

The system must write the Erase Resume command (address bits are “don’t care”) to exit the erase sus-

pend mode and continue the sector erase operation. Further writes of the Resume command are ignored. Another Erase Suspend command can be written after the device has resumed erasing.

### Temporary Unprotect Enable/Disable Command Sequence

The temporary unprotect command sequence is a four-bus-cycle operation. The sequence is initiated by writing two unlock write cycles. A third write cycle sets up the command. The fourth and final write cycle enables or disables the temporary unprotect feature. If the temporary unprotect feature is enabled, all sectors are temporarily unprotected. The system may program or erase data as needed. When the system writes the temporary unprotect disable command sequence, all sectors return to their previous protected or unprotected settings. See Table 10 for more information.

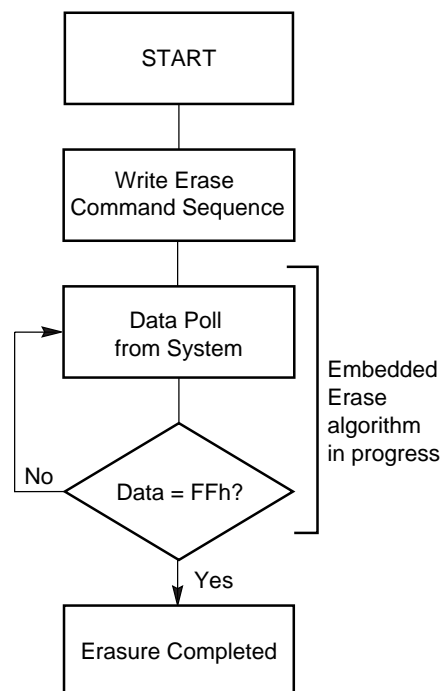

**Notes:**

1. See Table 10 for erase command sequence.
2. See "DQ3: Sector Erase Timer" for more information.

**Figure 2. Erase Operation**

## Command Definitions

**Table 10. Am29PL160C Command Definitions**

Command Sequence (Note 1)			Cycles	Bus Cycles (Notes 2–5)												
				First		Second		Third		Fourth		Fifth		Sixth		
				Addr	Data	Addr	Data	Addr	Data	Addr	Data	Addr	Data	Addr	Data	
Read (Note 6)			1	RA	RD											
Reset (Note 7)			1	XXX	F0											
Autoselect (Note 8)	Manufacturer ID	Word	4	555	AA	2AA	55	555	90	X00	01					
		Byte	4	AAA	AA	555	55	AAA	90	X01	2245					
	Device ID, Bottom Boot Block	Word	4	555	AA	2AA	55	555	90	X02	45					
		Byte	4	AAA	AA	555	55	AAA	90	(SA) X02	XX00					
	Sector Protect Verify (Note 9)	Word	4	555	AA	2AA	55	555	90	(SA) X02	XX01					
		Byte	4	AAA	AA	555	55	AAA	90	(SA) X04	00					
CFI Query (Note 10)	Word	1	55	98												
	Byte	1	AA													
Program	Word	4	555	AA	2AA	55	555	A0	PA	PD						
	Byte	4	AAA	AA	555	55	AAA	A0	PA	PD						
Unlock Bypass	Word	3	555	AA	2AA	55	555	20								
	Byte	3	AAA	AA	555	55	AAA	20								
Unlock Bypass Program (Note 11)			2	XXX	A0	PA	PD									
Unlock Bypass Reset (Note 12)			2	XXX	90	XXX	00									
Chip Erase	Word	6	555	AA	2AA	55	555	80	555	AA	2AA	55	555	10		
	Byte	6	AAA	AA	555	55	AAA	80	AAA	AA	555	55	AAA	10		
Sector Erase	Word	6	555	AA	2AA	55	555	80	555	AA	2AA	55	SA	30		
	Byte	6	AAA	AA	555	55	AAA	80	AAA	AA	555	55	SA	30		
Erase Suspend (Note 13)			1	XXX	B0											
Erase Resume (Note 14)			1	XXX	30											
Temporary Unprotect Enable	Word	4	555	AA	2AA	55	555	E0	XXX	01						
	Byte	4	AAA	AA	555	55	AAA	E0	XXX	01						
Temporary Unprotect Disable	Word	4	555	AA	2AA	55	555	E0	XXX	00						
	Byte	4	AAA	AA	555	55	AAA	E0	XXX	00						

**Legend:**

X = Don't care

RA = Address of the memory location to be read.

RD = Data read from location RA during read operation.

PA = Address of the memory location to be programmed. Addresses latch on the falling edge of the WE# or CE# pulse, whichever happens later.

PD = Data to be programmed at location PA. Data latches on the rising edge of WE# or CE# pulse, whichever happens first.

SA = Address of the sector to be verified (in autoselect mode) or erased. Address bits A19–A12 uniquely select any sector.

**Notes:**

- See Table 1 for description of bus operations.
- All values are in hexadecimal.
- Except for the read cycle and the fourth cycle of the autoselect command sequence, all bus cycles are write cycles.
- Data bits DQ15–DQ8 are don't cares for unlock and command cycles.
- Address bits A19–A11 are don't cares for unlock and command cycles, unless SA or PA required.
- No unlock or command cycles required when reading array data.
- The Reset command is required to return to reading array data when device is in the autoselect mode, or if DQ5 goes high (while the device is providing status data).
- The fourth cycle of the autoselect command sequence is a read cycle.
- The data is 00h for an unprotected sector and 01h for a protected sector. See "Autoselect Command Sequence" for more information.
- Command is valid when device is ready to read array data or when device is in autoselect mode.
- The Unlock Bypass command is required prior to the Unlock Bypass Program command.
- The Unlock Bypass Reset command is required to return to reading array data when the device is in the unlock bypass mode.
- The system may read and program in non-erasing sectors, or enter the autoselect mode, when in the Erase Suspend mode. The Erase Suspend command is valid only during a sector erase operation.
- The Erase Resume command is valid only during the Erase Suspend mode.

## WRITE OPERATION STATUS

The device provides several bits to determine the status of a write operation: DQ2, DQ3, DQ5, DQ6, and DQ7. Table 11 and the following subsections describe the functions of these bits. DQ7 and DQ6 each offer a method for determining whether a program or erase operation is complete or in progress. These three bits are discussed first.

### DQ7: Data# Polling

The Data# Polling bit, DQ7, indicates to the host system whether an Embedded Algorithm is in progress or completed, or whether the device is in Erase Suspend. Data# Polling is valid after the rising edge of the final WE# pulse in the program or erase command sequence.

During the Embedded Program algorithm, the device outputs on DQ7 the complement of the datum programmed to DQ7. This DQ7 status also applies to programming during Erase Suspend. When the Embedded Program algorithm is complete, the device outputs the datum programmed to DQ7. The system must provide the program address to read valid status information on DQ7. If a program address falls within a protected sector, Data# Polling on DQ7 is active for approximately 1  $\mu$ s, then the device returns to reading array data.

During the Embedded Erase algorithm, Data# Polling produces a “0” on DQ7. When the Embedded Erase algorithm is complete, or if the device enters the Erase Suspend mode, Data# Polling produces a “1” on DQ7. This is analogous to the complement/true datum output described for the Embedded Program algorithm: the erase function changes all the bits in a sector to “1”; prior to this, the device outputs the “complement,” or “0.” The system must provide an address within any of the sectors selected for erasure to read valid status information on DQ7.

After an erase command sequence is written, if all sectors selected for erasing are protected, Data# Polling on DQ7 is active for approximately 100  $\mu$ s, then the device returns to reading array data. If not all selected sectors are protected, the Embedded Erase algorithm erases the unprotected sectors, and ignores the selected sectors that are protected.

When the system detects DQ7 has changed from the complement to true data, it can read valid data at DQ7–DQ0 on the *following* read cycles. This is because DQ7 may change asynchronously with DQ0–

DQ6 while Output Enable (OE#) is asserted low. See Figure 16 in the “AC Characteristics” section.

Table 11 shows the outputs for Data# Polling on DQ7. Figure 3 shows the Data# Polling algorithm.

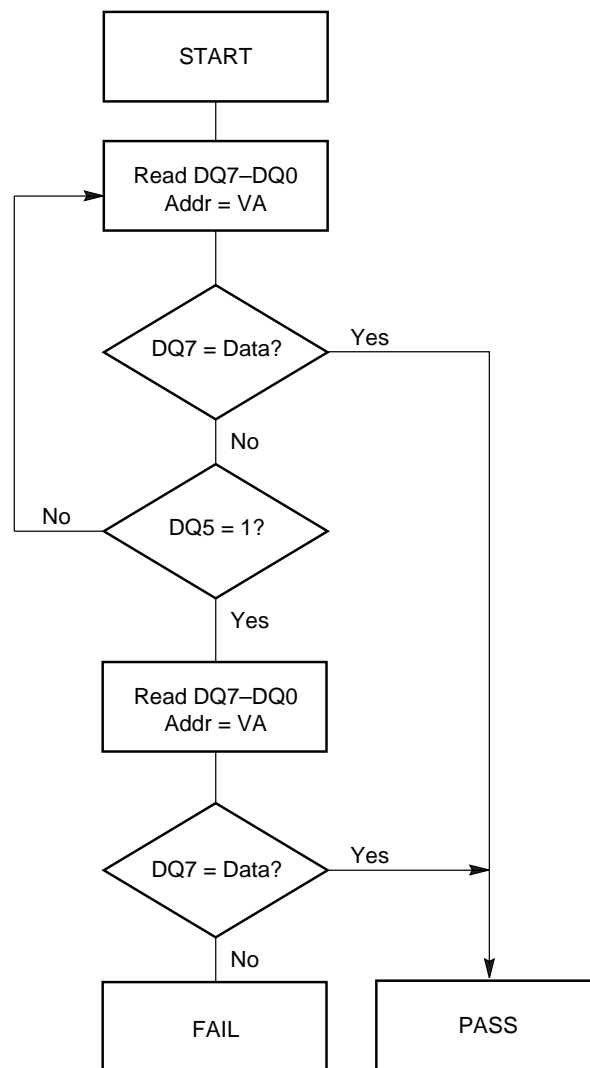

#### Notes:

1. VA = Valid address for programming. During a sector erase operation, a valid address is an address within any sector selected for erasure. During chip erase, a valid address is any non-protected sector address.
2. DQ7 should be rechecked even if DQ5 = “1” because DQ7 may change simultaneously with DQ5

Figure 3. Data# Polling Algorithm

## DQ6: Toggle Bit

Toggle Bit I on DQ6 indicates whether an Embedded Program or Erase algorithm is in progress or complete, or whether the device has entered the Erase Suspend mode. Toggle Bit I may be read at any address, and is valid after the rising edge of the final WE# pulse in the command sequence (prior to the program or erase operation), and during the sector erase time-out.

During an Embedded Program or Erase algorithm operation, successive read cycles to any address cause DQ6 to toggle. (The system may use either OE# or CE# to control the read cycles.) When the operation is complete, DQ6 stops toggling.

After an erase command sequence is written, if all sectors selected for erasing are protected, DQ6 toggles for approximately 100  $\mu$ s, then returns to reading array data. If not all selected sectors are protected, the Embedded Erase algorithm erases the unprotected sectors, and ignores the selected sectors that are protected.

The system can use DQ6 and DQ2 together to determine whether a sector is actively erasing or is erase-suspended. When the device is actively erasing (that is, the Embedded Erase algorithm is in progress), DQ6 toggles. When the device enters the Erase Suspend mode, DQ6 stops toggling. However, the system must also use DQ2 to determine which sectors are erasing or erase-suspended. Alternatively, the system can use DQ7 (see the subsection on “DQ7: Data# Polling”).

If a program address falls within a protected sector, DQ6 toggles for approximately 1  $\mu$ s after the program command sequence is written, then returns to reading array data.

DQ6 also toggles during the erase-suspend-program mode, and stops toggling once the Embedded Program algorithm is complete.

Table 11 shows the outputs for Toggle Bit I on DQ6. Figure 4 shows the toggle bit algorithm in flowchart form, and the section “Reading Toggle Bits DQ6/DQ2” explains the algorithm. Figure 18 in the “AC Characteristics” section shows the toggle bit timing diagrams. Figure 19 shows the differences between DQ2 and DQ6 in graphical form. See also the subsection on “DQ2: Toggle Bit”.

## DQ2: Toggle Bit

The “Toggle Bit II” on DQ2, when used with DQ6, indicates whether a particular sector is actively erasing (that is, the Embedded Erase algorithm is in progress), or whether that sector is erase-suspended. Toggle Bit II is valid after the rising edge of the final WE# pulse in the command sequence.

DQ2 toggles when the system reads at addresses within those sectors that have been selected for erasure. (The system may use either OE# or CE# to control the read cycles.) But DQ2 cannot distinguish whether the sector is actively erasing or is erase-suspended. DQ6, by comparison, indicates whether the device is actively erasing, or is in Erase Suspend, but cannot distinguish which sectors are selected for erasure. Thus, both status bits are required for sector and mode information. Refer to Table 11 to compare outputs for DQ2 and DQ6.

Figure 4 shows the toggle bit algorithm in flowchart form, and the section “Reading Toggle Bits DQ6/DQ2” explains the algorithm. See also the DQ6: Toggle Bit subsection. Figure 18 shows the toggle bit timing diagram. Figure 19 shows the differences between DQ2 and DQ6 in graphical form.

## Reading Toggle Bits DQ6/DQ2

Refer to Figure 4 for the following discussion. Whenever the system initially begins reading toggle bit status, it must read DQ7–DQ0 at least twice in a row to determine whether a toggle bit is toggling. Typically, the system would note and store the value of the toggle bit after the first read. After the second read, the system would compare the new value of the toggle bit with the first. If the toggle bit is not toggling, the device has completed the program or erase operation. The system can read array data on DQ7–DQ0 on the following read cycle.

However, if after the initial two read cycles, the system determines that the toggle bit is still toggling, the system also should note whether the value of DQ5 is high (see the section on DQ5). If it is, the system should then determine again whether the toggle bit is toggling, since the toggle bit may have stopped toggling just as DQ5 went high. If the toggle bit is no longer toggling, the device has successfully completed the program or erase operation. If it is still toggling, the device did not complete the operation successfully, and the system must write the reset command to return to reading array data.

The remaining scenario is that the system initially determines that the toggle bit is toggling and DQ5 has not gone high. The system may continue to monitor the toggle bit and DQ5 through successive read cycles, determining the status as described in the previous paragraph. Alternatively, it may choose to perform other system tasks. In this case, the system must start at the beginning of the algorithm when it returns to determine the status of the operation (top of Figure 4).

## DQ5: Exceeded Timing Limits

DQ5 indicates whether the program or erase time has exceeded a specified internal pulse count limit. Under these conditions DQ5 produces a “1.” This is a failure

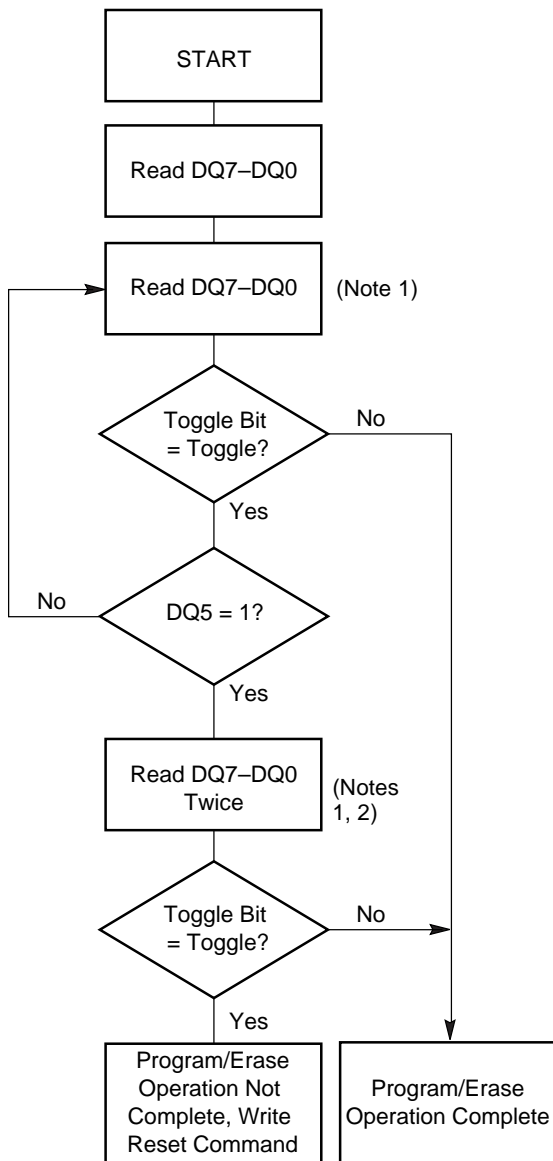
**Notes:**

1. Read toggle bit twice to determine whether or not it is toggling. See text.
2. Recheck toggle bit because it may stop toggling as DQ5 changes to "1". See text.

**Figure 4. Toggle Bit Algorithm**

condition that indicates the program or erase cycle was not successfully completed.

The DQ5 failure condition may appear if the system tries to program a "1" to a location that is previously programmed to "0." **Only an erase operation can change a "0" back to a "1."** Under this condition, the device halts the operation, and when the operation has exceeded the timing limits, DQ5 produces a "1."

Under both these conditions, the system must issue the reset command to return the device to reading array data.

**DQ3: Sector Erase Timer**

After writing a sector erase command sequence, the system may read DQ3 to determine whether or not an erase operation has begun. (The sector erase timer does not apply to the chip erase command.) If additional sectors are selected for erasure, the entire time-out also applies after each additional sector erase command. When the time-out is complete, DQ3 switches from "0" to "1." The system may ignore DQ3 if the system can guarantee that the time between additional sector erase commands will always be less than 50  $\mu$ s. See also the "Write Operation Status" section.

After the sector erase command sequence is written, the system should read the status on DQ7 (Data# Polling) or DQ6 (Toggle Bit I) to ensure the device has accepted the command sequence, and then read DQ3. If DQ3 is "1", the internally controlled erase cycle has begun; all further commands (other than Erase Suspend) are ignored until the erase operation is complete. If DQ3 is "0", the device will accept additional sector erase commands. To ensure the command has been accepted, the system software should check the status of DQ3 prior to and following each subsequent sector erase command. If DQ3 is high on the second status check, the last command might not have been accepted. Table 11 shows the outputs for DQ3.

**Table 11. Write Operation Status**

Operation		DQ7 (Note 2)	DQ6	DQ5 (Note 1)	DQ3	DQ2 (Note 2)
Standard Mode	Embedded Program Algorithm	DQ7#	Toggle	0	N/A	No toggle
	Embedded Erase Algorithm	0	Toggle	0	1	Toggle
Erase Suspend Mode	Reading within Erase Suspended Sector	1	No toggle	0	N/A	Toggle
	Reading within Non-Erase Suspended Sector	Data	Data	Data	Data	Data
	Erase-Suspend-Program	DQ7#	Toggle	0	N/A	N/A

**Notes:**

1. DQ5 switches to '1' when an Embedded Program or Embedded Erase operation has exceeded the maximum timing limits. See "DQ5: Exceeded Timing Limits" for more information.
2. DQ7 and DQ2 require a valid address when reading status information. Refer to the appropriate subsection for further details.

## ABSOLUTE MAXIMUM RATINGS

Storage Temperature	
Plastic Packages . . . . .	-65°C to +150°C
Ambient Temperature	
with Power Applied . . . . .	-65°C to +125°C
Voltage with Respect to Ground	
$V_{CC}$ (Note 1) . . . . .	-0.5 V to +4.0 V
A9 and OE# (Note 2) . . . . .	-0.5 V to +13.0 V
All other pins (Note 1) . . . . .	-0.5 V to +5.5 V
Output Short Circuit Current (Note 3) . . . . .	200 mA

**Notes:**

1. Minimum DC voltage on input or I/O pins is -0.5 V. During voltage transitions, input at I/O pins may overshoot  $V_{SS}$  to -2.0 V for periods of up to 20 ns. Maximum DC voltage on output and I/O pins is  $V_{CC} + 0.5$  V. During voltage transitions output pins may overshoot to  $V_{CC} + 2.0$  V for periods up to 20 ns.
2. Minimum DC input voltage on pins A9 and OE# is -0.5 V. During voltage transitions, A9 and OE# may overshoot  $V_{SS}$  to -2.0 V for periods of up to 20 ns. Maximum DC input voltage on pin A9 and OE# is +13.0 V which may overshoot to 14.0 V for periods up to 20 ns.
3. No more than one output may be shorted to ground at a time. Duration of the short circuit should not be greater than one second.
4. Stresses above those listed under "Absolute Maximum Ratings" may cause permanent damage to the device. This is a stress rating only; functional operation of the device at these or any other conditions above those indicated in the operational sections of this data sheet is not implied. Exposure of the device to absolute maximum rating conditions for extended periods may affect device reliability.

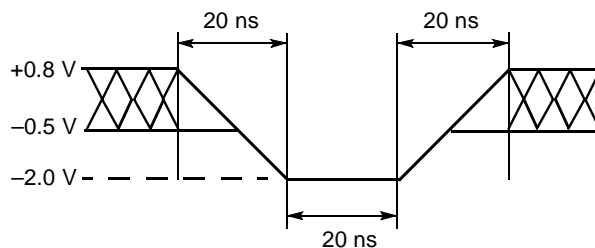

**Figure 5. Maximum Negative Overshoot Waveform**

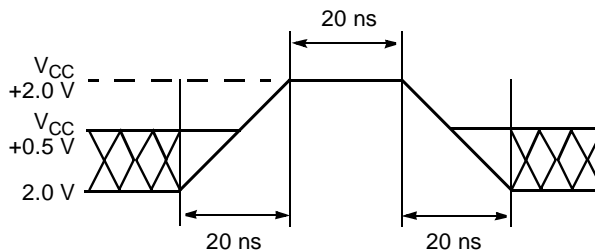

**Figure 6. Maximum Positive Overshoot Waveform**

## OPERATING RANGES

**Commercial (C) Devices**

Ambient Temperature ( $T_A$ ) . . . . . 0°C to +70°C

**Industrial (I) Devices**

Ambient Temperature ( $T_A$ ) . . . . . -40°C to +85°C

**$V_{CC}$  Supply Voltages**

$V_{CC}$  for regulated voltage range . . . . . 3.0 V to 3.6 V

$V_{CC}$  for full voltage range . . . . . 2.7 V to 3.6 V

Operating ranges define those limits between which the functionality of the device is guaranteed.

## DC CHARACTERISTICS

### CMOS Compatible

Parameter Symbol	Description	Test Conditions	Min	Typ	Max	Unit
$I_{LI}$	Input Load Current	$V_{IN} = V_{SS}$ to 5.5 V, $V_{CC} = V_{CC\ max}$			$\pm 1.0$	$\mu A$
$I_{LIT}$	A9 Input Load Current	$V_{CC} = V_{CC\ max}$ ; A9 = 12.5 V			35	$\mu A$
$I_{LO}$	Output Leakage Current	$V_{OUT} = V_{SS}$ to 5.5 V, $V_{CC} = V_{CC\ max}$			$\pm 1.0$	$\mu A$
$I_{CC1}$	$V_{CC}$ Active Read Current (Notes 1, 2)	$CE\# = V_{IL}$ , $OE\# = V_{IH}$		30	50	mA
$I_{CC2}$	$V_{CC}$ Active Write Current (Notes 2, 4, 5)	$CE\# = V_{IL}$ , $OE\# = V_{IH}$		20	30	mA
$I_{CC3}$	$V_{CC}$ Standby Current (Note 2)	$CE\# = V_{CC} \pm 0.3$ V		1	5	$\mu A$
$I_{CC4}$	Automatic Sleep Mode (Notes 2, 3, 6)	$V_{IH} = V_{CC} \pm 0.3$ V; $V_{IL} = V_{SS} \pm 0.3$ V	$OE\# = V_{IH}$	1	5	$\mu A$
			$OE\# = V_{IL}$	8	20	
$V_{IL}$	Input Low Voltage		-0.5		0.8	V
$V_{IH}$	Input High Voltage		$0.7 \times V_{CC}$		5.5	V
$V_{ID}$	Voltage for Autoselect and Temporary Sector Unprotect	$V_{CC} = 3.3$ V	11.5		12.5	V
$V_{OL}$	Output Low Voltage	$I_{OL} = 4.0$ mA, $V_{CC} = V_{CC\ min}$			0.45	V
$V_{OH1}$	Output High Voltage	$I_{OH} = -2.0$ mA, $V_{CC} = V_{CC\ min}$	$0.85 \times V_{CC}$			V
$V_{OH2}$		$I_{OH} = -100$ $\mu A$ , $V_{CC} = V_{CC\ min}$	$V_{CC} - 0.4$			
$V_{LKO}$	Low $V_{CC}$ Lock-Out Voltage (Note 4)		2.3		2.5	V

#### Notes:

1. The  $I_{CC}$  current listed is typically less than 2 mA/MHz, with  $OE\#$  at  $V_{IH}$ . Typical  $V_{CC}$  is 3.0 V.
2. Maximum  $I_{CC}$  specifications are tested with  $V_{CC} = V_{CC\ max}$ .
3. The Automatic Sleep Mode current is dependent on the state of  $OE\#$ .
4.  $I_{CC}$  active while Embedded Erase or Embedded Program is in progress.
5. Automatic sleep mode enables the low power mode when addresses remain stable for  $t_{ACC} + 30$  ns. Typical sleep mode current is 200 nA.
6. Not 100% tested.

DC CHARACTERISTICS (Continued)

Zero Power Flash

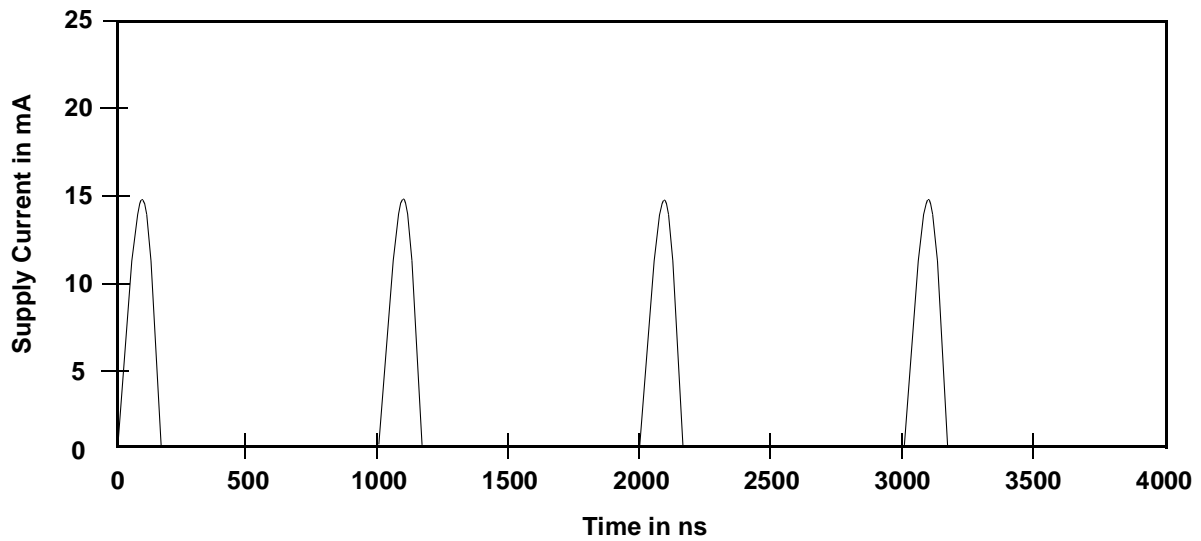

Note: Addresses are switching at 1 MHz

Figure 7.  $I_{CC1}$  Current vs. Time (Showing Active and Automatic Sleep Currents)

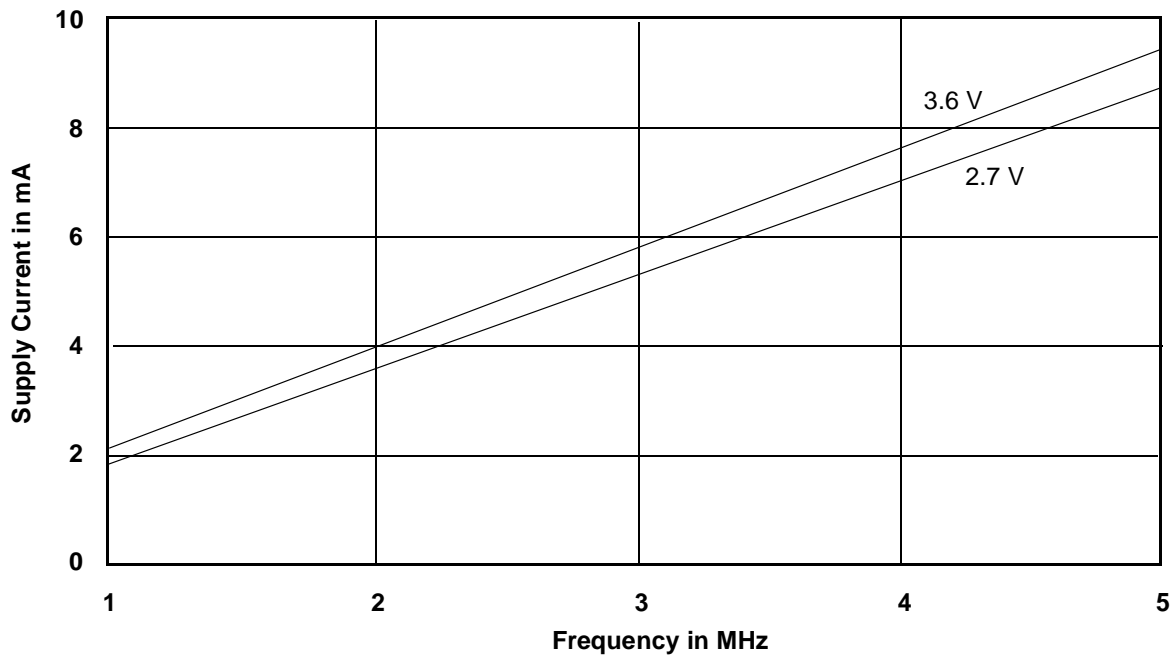

Note:  $T = 25^{\circ}\text{C}$

Figure 8. Typical  $I_{CC1}$  vs. Frequency

TEST CONDITIONS

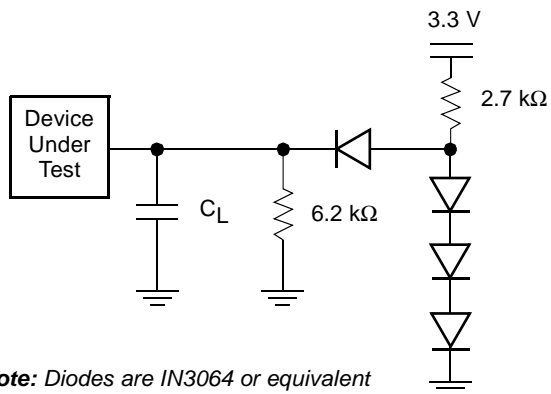

Note: Diodes are IN3064 or equivalent

Figure 9. Test Setup

Table 12. Test Specifications

Test Condition	-65R	-70R, -90, -120	Unit
Output Load	1 TTL gate		
Output Load Capacitance, C <sub>L</sub> (including jig capacitance)	30	100	pF
Input Rise and Fall Times	5		ns
Input Pulse Levels	0.0–3.0		V
Input timing measurement reference levels	1.5		V
Output timing measurement reference levels	1.5		V

KEY TO SWITCHING WAVEFORMS

WAVEFORM	INPUTS	OUTPUTS
		Steady
		Changing from H to L
		Changing from L to H
	Don't Care, Any Change Permitted	Changing, State Unknown
	Does Not Apply	Center Line is High Impedance State (High Z)

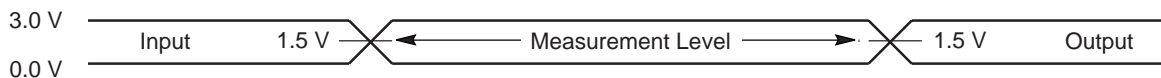

Figure 10. Input Waveforms and Measurement Levels

## AC CHARACTERISTICS

## Read Operations

Parameter		Description	Test Setup		Speed Options				Unit
JEDEC	Std				-65R	-70R	-90	-120	
$t_{AVAV}$	$t_{RC}$	Read Cycle Time		Min	65	70	90	120	ns
$t_{AVQV}$	$t_{ACC}$	Address Access Time	CE#=V <sub>IL</sub> , OE#=V <sub>IL</sub>	Max	65	70	90	120	ns
$t_{ELQV}$	$t_{CE}$	Chip Enable to Output Delay	OE#=V <sub>IL</sub>	Max	65	70	90	120	ns
	$t_{PACC}$	Page Access Time		Max	25	25	30	30	ns
$t_{GLQV}$	$t_{OE}$	Output Enable to Output Valid		Max	25	25	30	30	ns
$t_{EHQZ}$	$t_{DF}$	Chip Enable to Output High Z		Max	20				ns
$t_{GHQZ}$	$t_{DF}$	Output Enable to Output High Z		Max	20				ns
	$t_{OEH}$	Output Enable Hold Time (Note 1)	Read		0				ns
			Toggle and Data# Polling		10				ns
$t_{AXQX}$	$t_{OH}$	Output Hold Time from Addresses		Min	0				ns

**Notes:**

1. Not 100% tested.
2. See Figure 9 and Table 12 for test specifications.

AC CHARACTERISTICS

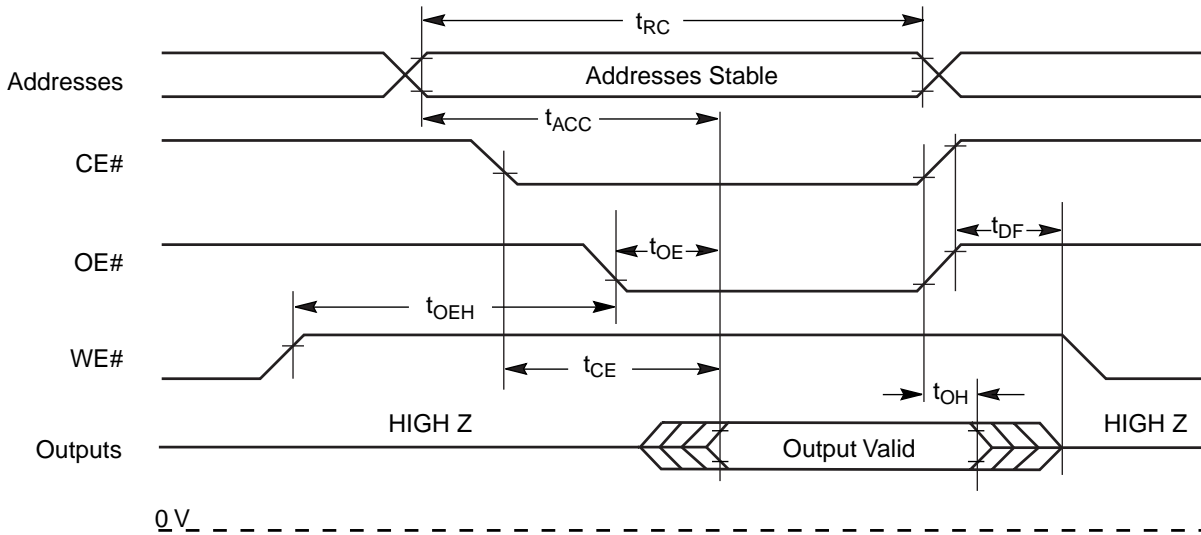
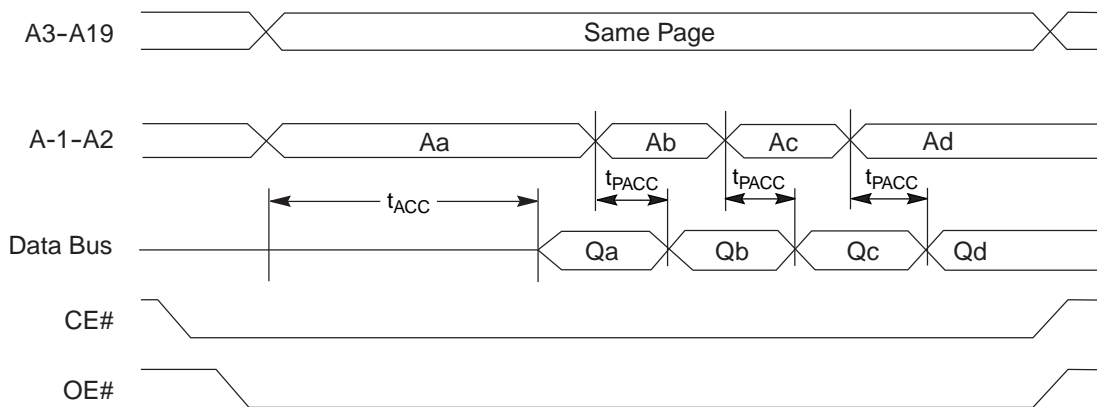

Figure 11. Conventional Read Operations Timings



Note: Word Configuration: Toggle A0, A1, A2. Byte Configuration: Toggle A-1, A0, A1, A2.

Figure 12. Page Read Timings

## AC CHARACTERISTICS

### Word/Byte Configuration (BYTE#)

Parameter		Description		Speed Options				Unit
JEDEC	Std			-65R	-70R	-90	-120	
	$t_{ELFL}/t_{ELFH}$	CE# to BYTE# Switching Low or High	Max	5				ns
	$t_{FLQZ}$	BYTE# Switching Low to Output HIGH Z	Max	25	25	30	30	ns
	$t_{FHQV}$	BYTE# Switching High to Output Active	Min	65	70	90	120	ns

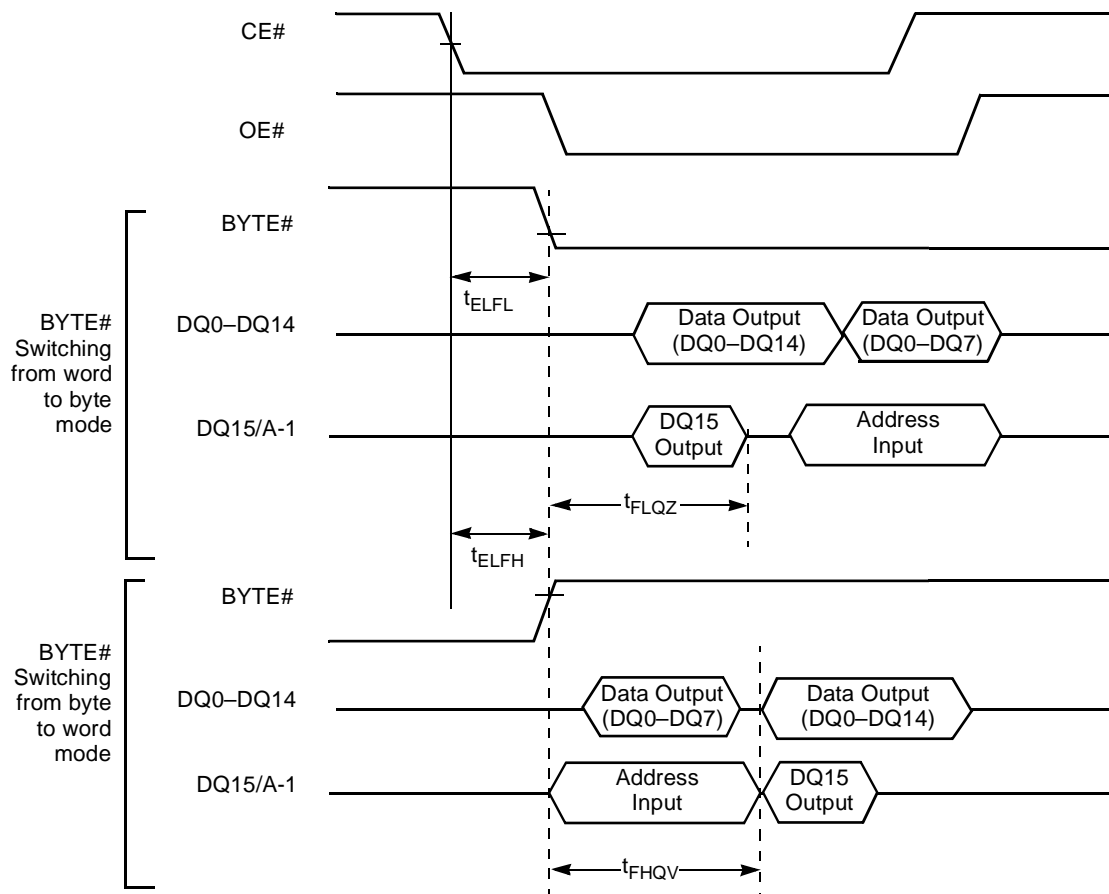
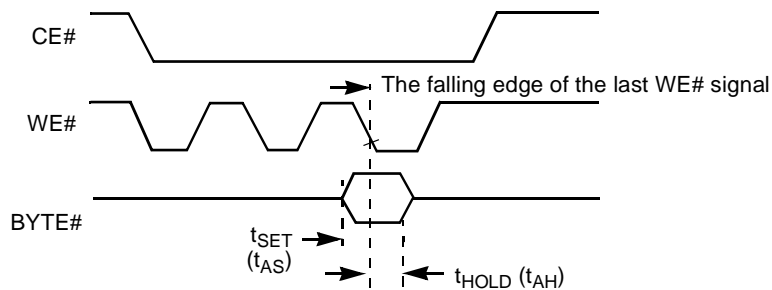

Figure 13. BYTE# Timings for Read Operations



Note: Refer to the Erase/Program Operations table for  $t_{AS}$  and  $t_{AH}$  specifications.

Figure 14. BYTE# Timings for Write Operations

## AC CHARACTERISTICS

### Program/Erase Operations

Parameter		Description		Speed Options				Unit
JEDEC	Std			-65R	-70R	-90	-120	
$t_{AVAV}$	$t_{WC}$	Write Cycle Time (Note 1)	Min	65	70	90	120	ns
$t_{AVWL}$	$t_{AS}$	Address Setup Time	Min	0				ns
$t_{WLAX}$	$t_{AH}$	Address Hold Time	Min	45	45	45	50	ns
$t_{DVWH}$	$t_{DS}$	Data Setup Time	Min	35	35	45	50	ns
$t_{WHDX}$	$t_{DH}$	Data Hold Time	Min	0				ns
	$t_{OES}$	Output Enable Setup Time	Min	0				ns
$t_{GHWL}$	$t_{GHWL}$	Read Recovery Time Before Write (OE# High to WE# Low)	Min	0				ns
$t_{ELWL}$	$t_{CS}$	CE# Setup Time	Min	0				ns
$t_{WHEH}$	$t_{CH}$	CE# Hold Time	Min	0				ns
$t_{WLWH}$	$t_{WP}$	Write Pulse Width	Min	35	35	35	50	ns
$t_{WHWL}$	$t_{WPH}$	Write Pulse Width High	Min	30				ns
$t_{WHWH1}$	$t_{WHWH1}$	Programming Operation (Note 2)	Byte	Typ				$\mu$ s
			Word	Typ				
$t_{WHWH2}$	$t_{WHWH2}$	Sector Erase Operation (Note 2)	Typ	5				sec
	$t_{VCS}$	$V_{CC}$ Setup Time (Note 1)	Min	50				$\mu$ s

**Notes:**

1. Not 100% tested.
2. See the "Erase and Programming Performance" section for more information.

## AC CHARACTERISTICS

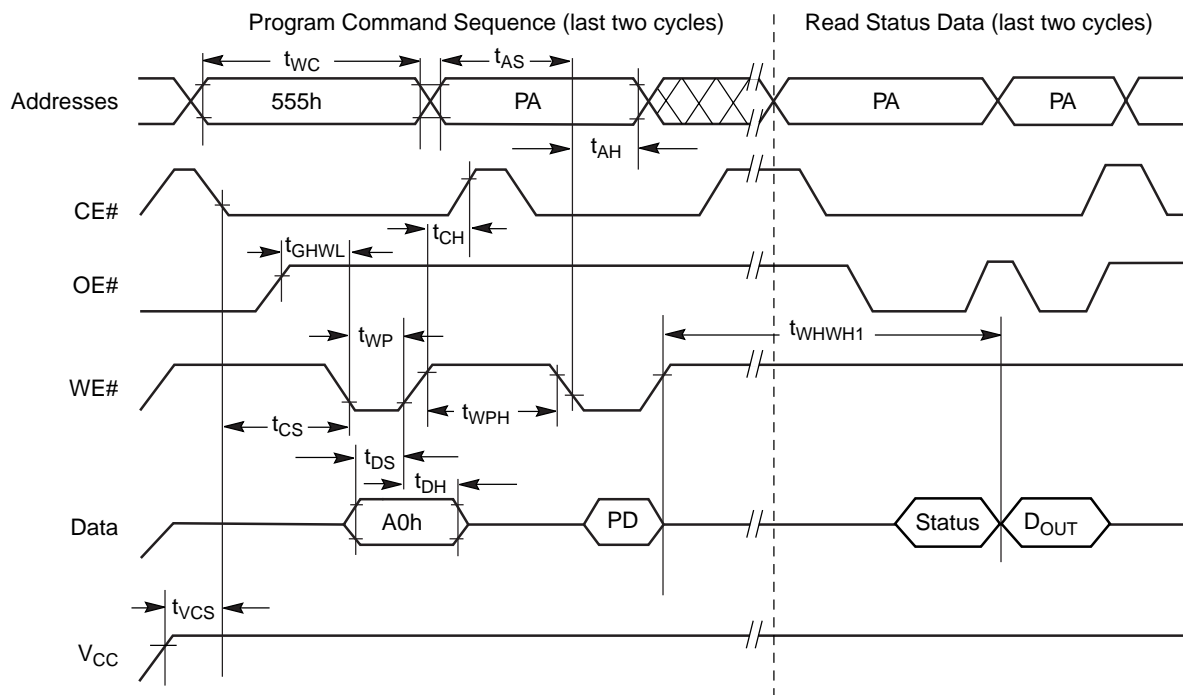

**Notes:**

1. PA = program address, PD = program data, D<sub>OUT</sub> is the true data at the program address.
2. Illustration shows device in word mode.

**Figure 15. Program Operation Timings**

AC CHARACTERISTICS

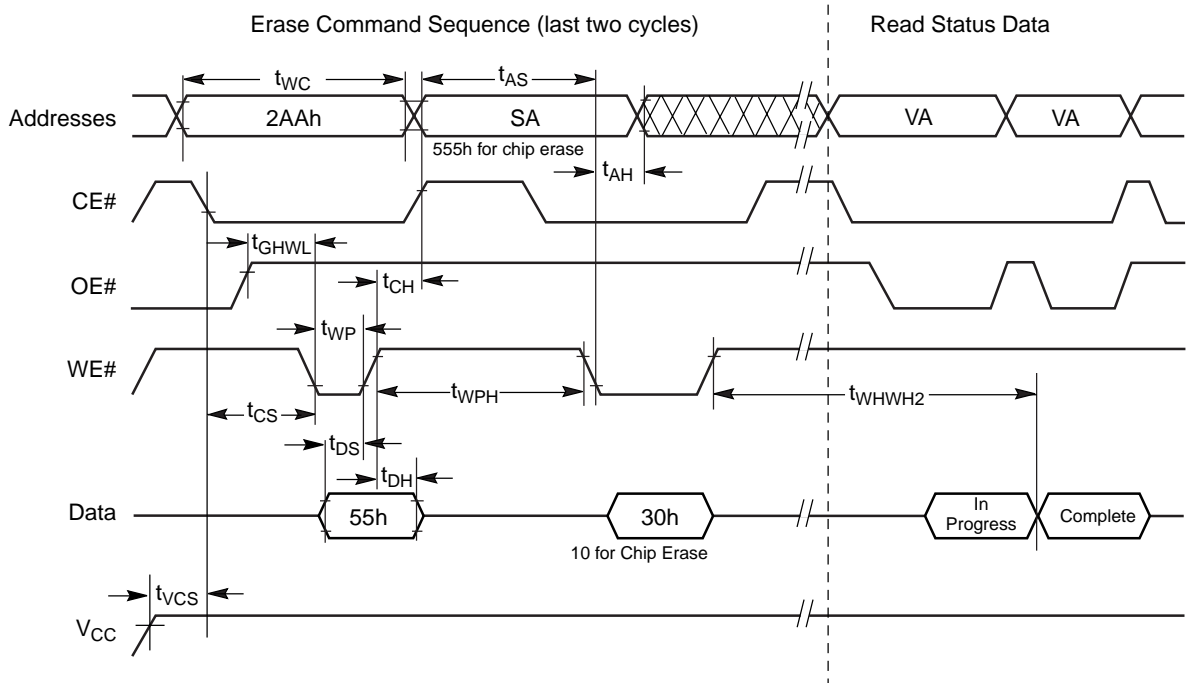

Notes:

1. SA = sector address (for Sector Erase), VA = Valid Address for reading status data (see "Write Operation Status").
2. Illustration shows device in word mode.

Figure 16. AC Waveforms for Chip/Sector Erase Operations

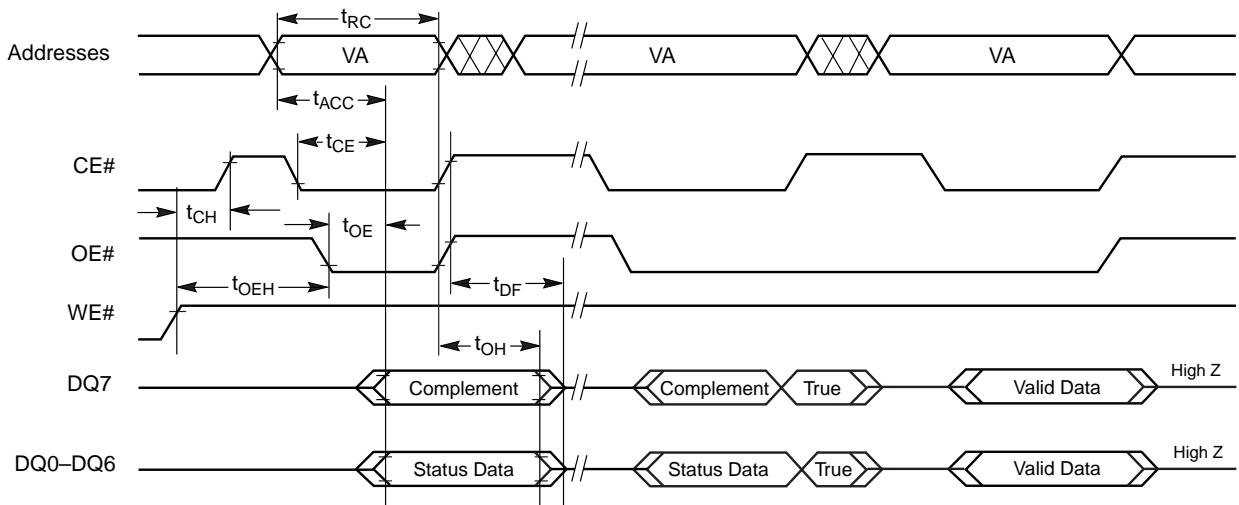

Note: VA = Valid address. Illustration shows first status cycle after command sequence, last status read cycle, and array data read cycle

Figure 17. Data# Polling Timings (During Embedded Algorithms)

AC CHARACTERISTICS

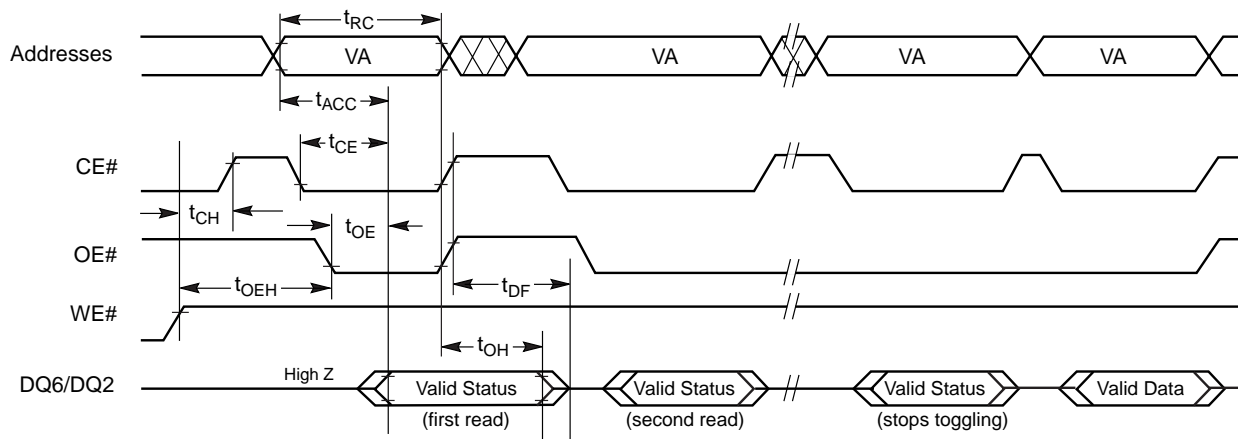

**Note:** VA = Valid address; not required for DQ6. Illustration shows first two status cycle after command sequence, last status read cycle, and array data read cycle

Figure 18. Toggle Bit Timings (During Embedded Algorithms)

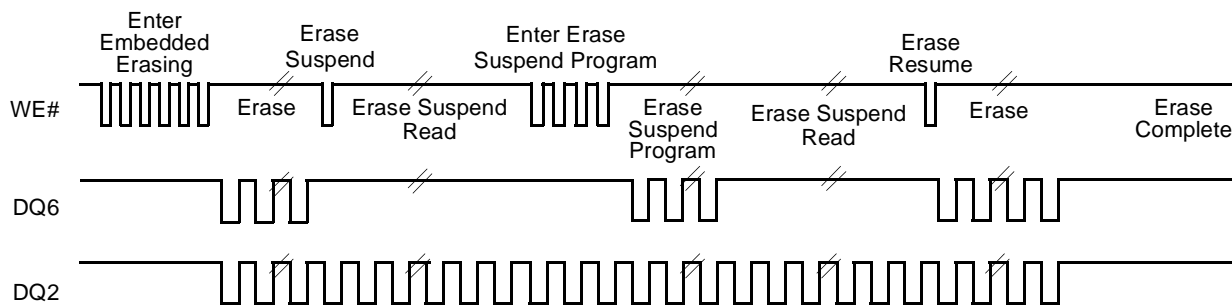

**Note:** The system may use CE# or OE# to toggle DQ2 and DQ6. DQ2 toggles only when read at an address within an erase-suspended sector.

Figure 19. DQ2 vs. DQ6 for Erase and Erase Suspend Operations

## AC CHARACTERISTICS

### Alternate CE# Controlled Erase/Program Operations

Parameter		Description		Speed Options				Unit
JEDEC	Std			-65R	-70R	-90	-120	
$t_{AVAV}$	$t_{WC}$	Write Cycle Time (Note 1)	Min	65	70	90	120	ns
$t_{AVEL}$	$t_{AS}$	Address Setup Time	Min	0				ns
$t_{ELAX}$	$t_{AH}$	Address Hold Time	Min	45	45	45	50	ns
$t_{DVEH}$	$t_{DS}$	Data Setup Time	Min	35	35	45	50	ns
$t_{EHDX}$	$t_{DH}$	Data Hold Time	Min	0				ns
	$t_{OES}$	Output Enable Setup Time	Min	0				ns
$t_{GHLEL}$	$t_{GHLEL}$	Read Recovery Time Before Write (OE# High to WE# Low)	Min	0				ns
$t_{WLEL}$	$t_{WS}$	WE# Setup Time	Min	0				ns
$t_{EHWH}$	$t_{WH}$	WE# Hold Time	Min	0				ns
$t_{ELEH}$	$t_{CP}$	CE# Pulse Width	Min	35	35	35	50	ns
$t_{EHLEL}$	$t_{CPH}$	CE# Pulse Width High	Min	30				ns
$t_{WHWH1}$	$t_{WHWH1}$	Programming Operation (Note 2)	Byte	Typ				$\mu$ s
			Word	Typ				
$t_{WHWH2}$	$t_{WHWH2}$	Sector Erase Operation (Note 2)	Typ	5				sec

**Notes:**

1. Not 100% tested.
2. See the "Erase and Programming Performance" section for more information.

AC CHARACTERISTICS

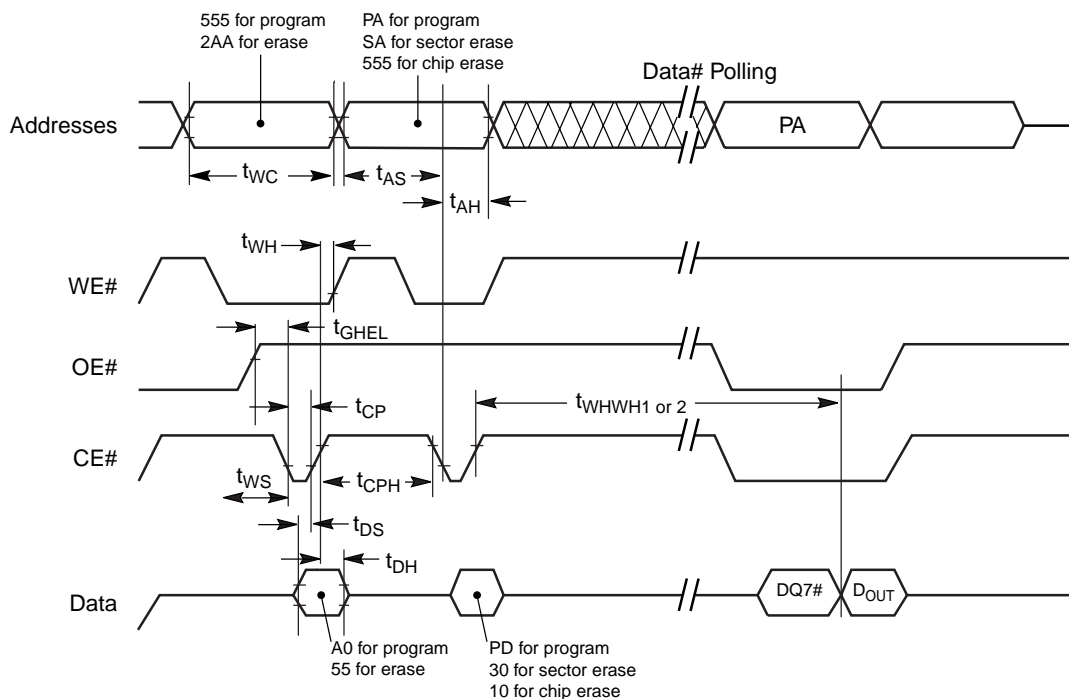

**Notes:**

1. PA = program address, PD = program data, DQ7# = complement of the data written to the device, D<sub>OUT</sub> = data written to the device.
2. Figure indicates the last two bus cycles of the command sequence.
3. Word mode address used as an example.

**Figure 20. Alternate CE# Controlled Write Operation Timings**

## ERASE AND PROGRAMMING PERFORMANCE

Parameter		Typ (Note 1)	Max (Note 2)	Unit	Comments
Sector Erase Time		5	60	s	Excludes 00h programming prior to erasure (Note 4)
Chip Erase Time		40		s	
Byte Programming Time		7	300	μs	Excludes system level overhead (Note 5)
Word Programming Time		9	360	μs	
Chip Programming Time (Note 3)	Byte Mode	14	42	s	
	Word Mode	9	27	s	

### Notes:

1. Typical program and erase times assume the following conditions: 25°C, 3.0 V  $V_{CC}$ , 1,000,000 cycles. Additionally, programming typicals assume checkerboard pattern.
2. Under worst case conditions of 90°C,  $V_{CC} = 2.7$  V, 1,000,000 cycles.
3. The typical chip programming time is considerably less than the maximum chip programming time listed, since most bytes program faster than the maximum program times listed.
4. In the pre-programming step of the Embedded Erase algorithm, all bytes are programmed to 00h before erasure.
5. System-level overhead is the time required to execute the two- or four-bus-cycle sequence for the program command. See Table 10 for further information on command definitions.
6. The device has a minimum erase and program cycle endurance of 1,000,000 cycles.

## LATCHUP CHARACTERISTICS

Description	Min	Max
Input voltage with respect to $V_{SS}$ on all pins except I/O pins (including A9 and OE#)	-1.0 V	12.5 V
Input voltage with respect to $V_{SS}$ on all I/O pins	-1.0 V	$V_{CC} + 1.0$ V
$V_{CC}$ Current	-100 mA	+100 mA

Includes all pins except  $V_{CC}$ . Test conditions:  $V_{CC} = 3.0$  V, one pin at a time.

## TSOP AND SO PIN CAPACITANCE

Parameter Symbol	Parameter Description	Test Setup	Typ	Max	Unit	
$C_{IN}$	Input Capacitance	$V_{IN} = 0$	6	7.5	pF	
$C_{OUT}$	Output Capacitance	$V_{OUT} = 0$	8.5	12	pF	
$C_{IN2}$	Control Pin Capacitance	$V_{IN} = 0$	TSOP	7.5	9	pF
			SO	8	10	pF

### Notes:

1. Sampled, not 100% tested.
2. Test conditions  $T_A = 25^\circ\text{C}$ ,  $f = 1.0$  MHz.

## DATA RETENTION

Parameter	Test Conditions	Min	Unit
Minimum Pattern Data Retention Time	150°C	10	Years
	125°C	20	Years

\* For reference only. BSC is an ANSI standard for Basic Space Centering.



PHYSICAL DIMENSIONS

SO 044—44-Pin Small Outline Package, Standard Pinout

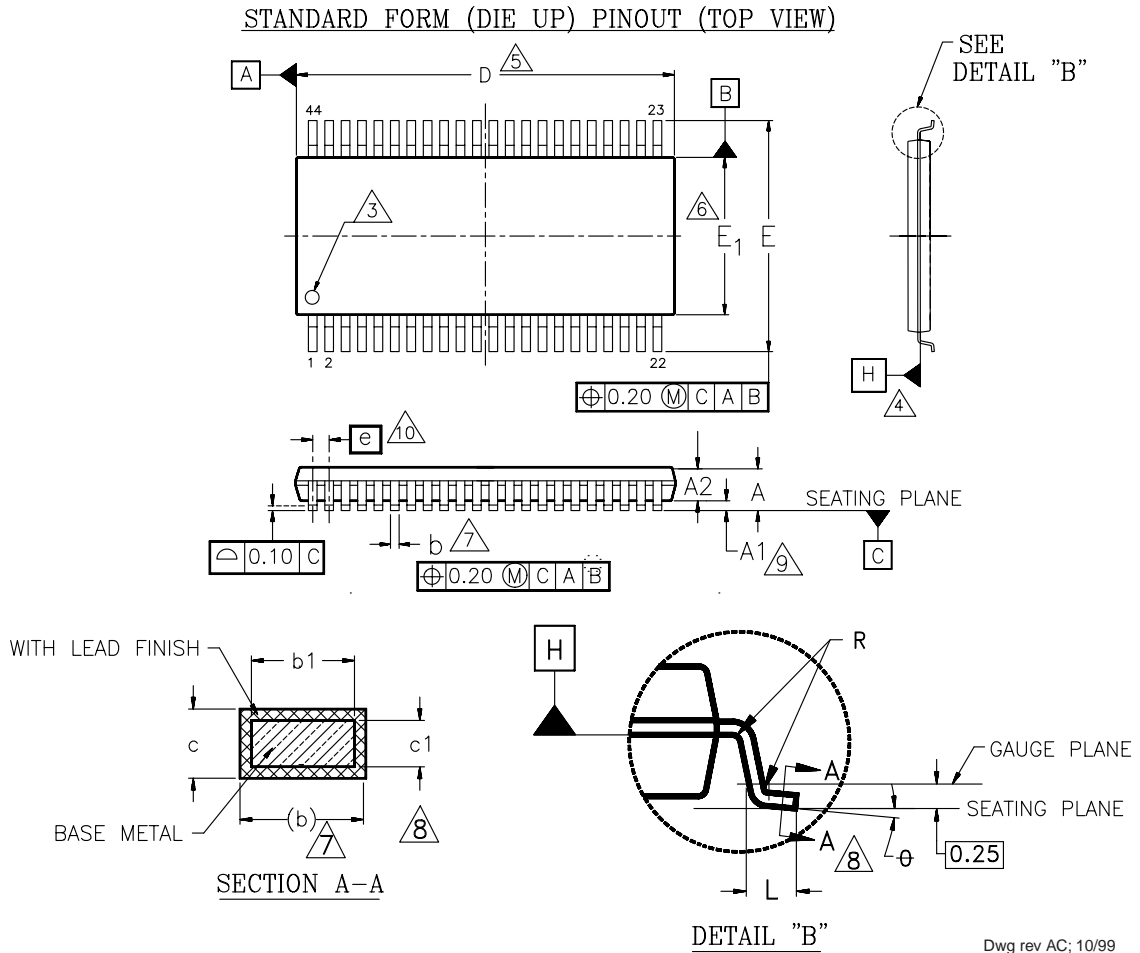

PACKAGE	SO 044		
JEDEC	MO-180 (A) AA		
SYMBOL	MIN	NDM	MAX
A	—	—	2.80
A1	0.15	0.23	0.35
A2	2.17	2.30	2.45
b	0.35	—	0.50
b1	0.35	0.40	0.45
c	0.10	—	0.21
c1	0.10	0.15	0.18
D	28.00	28.20	28.40
E	15.70	16.00	16.30
E1	13.10	13.30	13.50
e	1.27 BSC		
L	0.60	0.80	1.00
R	0.09	—	—
θ	0°	4°	8°

NOTES:

- CONTROLLING DIMENSIONS ARE IN MILLIMETERS (mm).
- DIMENSIONING AND TOLERANCING CONFORM TO ASME Y14.5M-1994.
- PIN 1 IDENTIFIER FOR STANDARD FORM (DIE UP) OR REVERSE FORM (DIE DOWN) PINOUTS.
- DATUMS A AND B AND DIMENSIONS D AND E1 ARE DETERMINED AT DATUM H.
- DIMENSION "D" DOES NOT INCLUDE MOLD FLASH, PROTUSIONS OR GATE BURRS. MOLD FLASH, PROTUSIONS OR GATE BURRS SHALL NOT EXCEED 0.15 mm PER END.
- DIMENSION "E1" DOES NOT INCLUDE INTERLEAD FLASH OR PROTUSION. INTERLEAD FLASH OR PROTUSION SHALL NOT EXCEED 0.25 mm PER SIDE.
- DIMENSION b DOES NOT INCLUDE DAMBAR PROTUSION/INTRUSION. ALLOWABLE DAMBAR PROTUSION SHALL NOT EXCEED 0.15 mm PER SIDE. DAMBAR INTRUSION SHALL NOT REDUCE DIMENSION b BY MORE THAN 0.07 mm AT LEAST MATERIAL CONDITION.
- THESE DIMENSIONS APPLY TO THE FLAT SECTION OF THE LEAD BETWEEN 0.10 mm AND 0.25 mm FROM THE LEAD TIPS.
- A1 IS DEFINED AS THE DISTANCE FROM THE SEATING PLANE TO THE LOWEST POINT OF THE PACKAGE.
- DIMENSION "e" IS MEASURED AT THE CENTERLINE OF THE LEADS.
- LEAD COPLANARITY SHALL BE WITHIN 0.10 mm AS MEASURED FROM THEIR SEATING PLANE.

PHYSICAL DIMENSIONS

SOR044—44-Pin Small Outline Package, Reverse Pinout

REVERSE FORM (DIE DOWN) PINOUT (TOP VIEW)

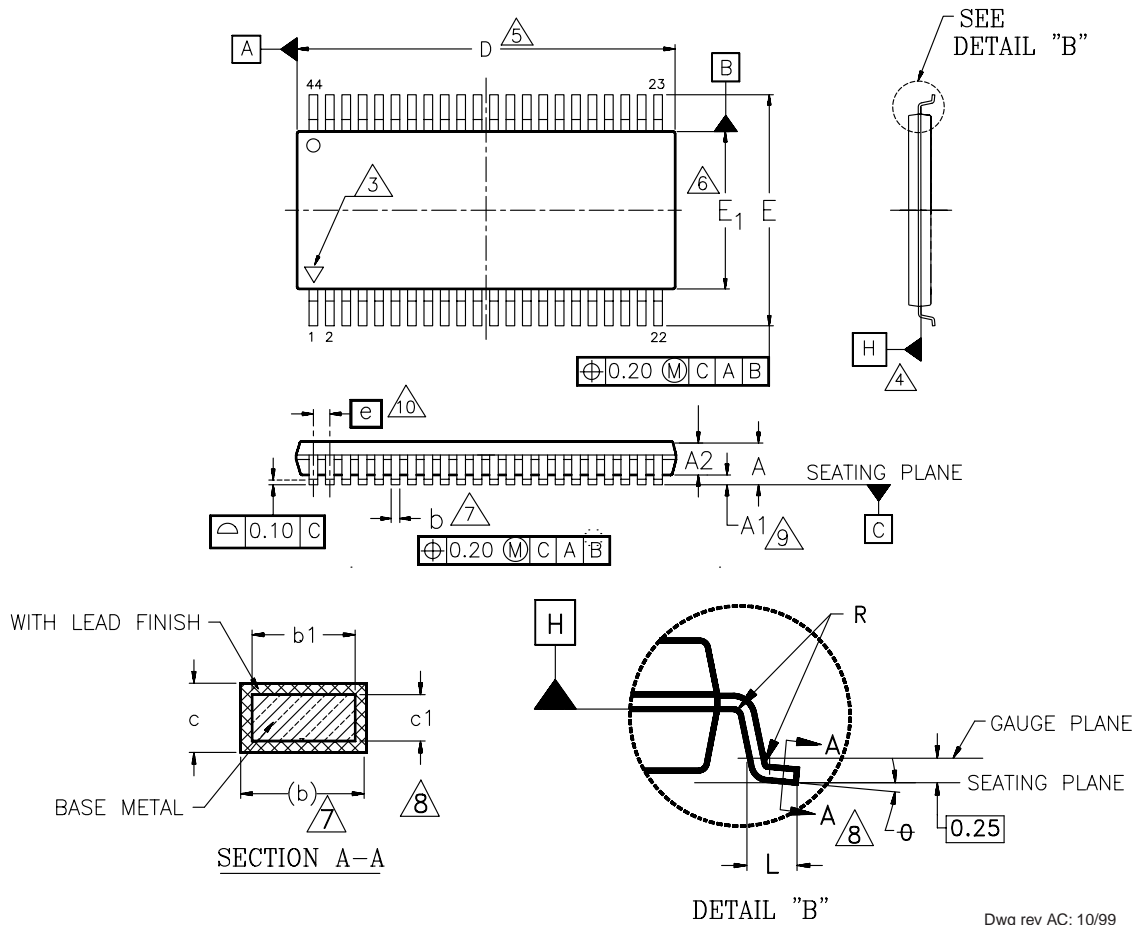

Dwg rev AC; 10/99

PACKAGE	SOR 044		
JEDEC	MO-180 (A) AA		
SYMBOL	MIN	NDM	MAX
A	—	—	2.80
A1	0.15	0.23	0.35
A2	2.17	2.30	2.45
b	0.35	—	0.50
b1	0.35	0.40	0.45
c	0.10	—	0.21
c1	0.10	0.15	0.18
D	28.00	28.20	28.40
E	15.70	16.00	16.30
E1	13.10	13.30	13.50
e	1.27 BSC		
L	0.60	0.80	1.00
R	0.09	—	—
θ	0°	4°	8°

NOTES:

- CONTROLLING DIMENSIONS ARE IN MILLIMETERS (mm).
- DIMENSIONING AND TOLERANCING CONFORM TO ASME Y14.5M-1994.
- PIN 1 IDENTIFIER FOR STANDARD FORM (DIE UP) OR REVERSE FORM (DIE DOWN) PINOUTS.
- DATUMS A AND B AND DIMENSIONS D AND E1 ARE DETERMINED AT DATUM H.
- DIMENSION "D" DOES NOT INCLUDE MOLD FLASH, PROTRUSIONS OR GATE BURRS. MOLD FLASH, PROTRUSIONS OR GATE BURRS SHALL NOT EXCEED 0.15 mm PER END.
- DIMENSION "E1" DOES NOT INCLUDE INTERLEAD FLASH OR PROTRUSION. INTERLEAD FLASH OR PROTRUSION SHALL NOT EXCEED 0.25 mm PER SIDE.
- DIMENSION b DOES NOT INCLUDE DAMBAR PROTRUSION/INTRUSION. ALLOWABLE DAMBAR PROTRUSION SHALL NOT EXCEED 0.15 mm PER SIDE. DAMBAR INTRUSION SHALL NOT REDUCE DIMENSION b BY MORE THAN 0.07 mm AT LEAST MATERIAL CONDITION.
- THESE DIMENSIONS APPLY TO THE FLAT SECTION OF THE LEAD BETWEEN 0.10 mm AND 0.25 mm FROM THE LEAD TIPS.
- A1 IS DEFINED AS THE DISTANCE FROM THE SEATING PLANE TO THE LOWEST POINT OF THE PACKAGE.
- DIMENSION "e" IS MEASURED AT THE CENTERLINE OF THE LEADS.
- LEAD COPLANARITY SHALL BE WITHIN 0.10 mm AS MEASURED FROM THEIR SEATING PLANE.

## REVISION SUMMARY

### Revision A (August 1998)

Initial release.

### Revision A+1 (September 1998)

#### Sector Protection/Unprotection

Added reference to Temporary Unprotect Enable/Disable command sequence.

#### Common Flash Memory Interface (CFI)

Deleted reference to upper address bits in word mode.

### Revision B (January 1999)

#### Ordering Information

Deleted commercial temperature rating.

#### DC Characteristics

Corrected  $I_{CC1}$  test condition for OE# to  $V_{IH}$ .

### Revision B+1 (February 1999)

#### DC Characteristics

Replaced TBDs for  $I_{CC4}$  with specifications.

### Revision B+2 (March 5, 1999)

#### Distinctive Characteristics

In the first subbullet under the Flexible Sector Architecture bullet, deleted the reference to “one 8 Kbyte” sector.

### Revision B+3 (May 14, 1999)

#### Global

Deleted the 60R speed option and added the 65R speed option.

#### Common Flash Memory Interface (CFI)

Corrected the data for the following CFI hex addresses: 38, 39, 3C, 4C.

#### Absolute Maximum Ratings

Corrected the maximum rating for all other pins to +5.5 V.

### Revision B+4 (June 25, 1999)

Changed data sheet status to preliminary. Deleted the 70 ns, full voltage range speed option.

### Revision B+5 (July 26, 1999)

#### Global

Added the reverse pinout SO package. Deleted the TSOP package.

#### Physical Dimensions

Restored section.

### Revision B+6 (September 2, 1999)

#### Connection Diagrams

Corrected the pinouts of pins 1, 2, 43, and 44 on the reverse SO diagram.

### Revision B+7 (February 4, 2000)

#### Global

Added 48-pin TSOP.

### Revision C (February 21, 2000)

#### Global

The “preliminary” designation has been removed from the document. Parameters are now stable, and only speed, package, and temperature range combinations are expected to change in future data sheet revisions.

Added dash to ordering part numbers.

### Revision C+1 (June 20, 2000)

#### Global

Deleted the SOR44 package. Deleted references to top boot configuration.

#### Product Selector Guide, Ordering Information

Added -90R speed option.

### Revision C+2 (June 28, 2000)

#### Command Definitions

Command Definitions table: Corrected address in the sixth cycle of the chip erase command sequence from 2AA to AAA.

### Revision C+3 (November 14, 2000)

Added table of contents.

### Revision C+4 (June 12, 2002)

#### Global

Deleted references to hardware reset (RESET#) input. Added reverse pinout SO package. Deleted 90R speed option.

#### TSOP and SO Pin Capacitance

Added TSOP pin capacitance.

**Trademarks**

Copyright © 2002 Advanced Micro Devices, Inc. All rights reserved.

AMD, the AMD logo, and combinations thereof are registered trademarks of Advanced Micro Devices, Inc.

ExpressFlash is a trademark of Advanced Micro Devices, Inc.

Product names used in this publication are for identification purposes only and may be trademarks of their respective companies.

This datasheet has been downloaded from:

[www.DatasheetCatalog.com](http://www.DatasheetCatalog.com)

Datasheets for electronic components.



LittleDiode supplies new, hard to find or obsolete electronic components and semiconductors all over the world.

With over two million different components listed you are sure to find the part you need.

Feel free to visit us today at our online store:

**[LittleDiode.com](http://LittleDiode.com)**

Looking forward to providing you with the best possible service.