

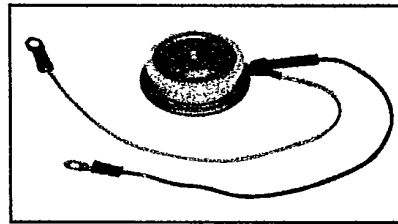

C430__X555

Powerex, Inc. Hills Street, Youngwood, Pennsylvania 15697 (412) 925-7272
 Powerex Europe, S.A., 428 Ave. G. Durand, BP107, 72003 LeMans, France (43) 72.75.15

Phase Control SCR
760 Amperes Avg
500-1300 Volts

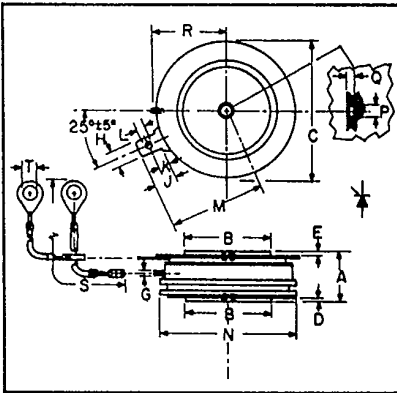

C430__X555
Phase Control SCR
 760 Amperes/500-1300 Volts

C430__X555
Outline Drawing

| Dimensions | Inches | | Millimeters | |
|------------|--------|--------|-------------|--------|
| | Min. | Max. | Min. | Max. |
| A | .560 | .605 | 14.22 | 15.37 |
| B | .985 | .995 | 25.01 | 25.27 |
| C | 1.600 | 1.650 | 40.64 | 41.91 |
| D | .030 | — | .76 | — |
| E | .040 | — | 1.01 | — |
| G | .057 | .059 | 1.44 | 1.50 |
| H | .186 | .191 | 4.72 | 4.85 |
| J | .245 | .255 | 6.22 | 6.48 |
| K | .115 | .130 | 2.92 | 3.30 |
| L | .064 | .070 | 1.62 | 1.78 |
| M | — | 1.120 | — | 28.45 |
| N | — | 1.585 | — | 40.26 |
| P | .135 | .145 | 3.42 | 3.68 |
| Q | .070 | .084 | 1.77 | 2.13 |
| R | — | .875 | — | 22.23 |
| S | 12.219 | 12.343 | 310.36 | 313.51 |
| T | .137 | .153 | 3.47 | 3.89 |

Description

Powerex Silicon Controlled Rectifiers (SCR) are designed for phase control applications. These are all-diffused, Press-Pak (Pow-R-Disc) devices employing the field-proven amplifying (di/namic) gate.

Features:

- Low On-State Voltage
- High di/dt
- High dv/dt
- Hermetic Packaging
- Excellent Surge and I²t Ratings
- High Temperature Operation

Applications:

- Power Supplies
- Battery Chargers
- Motor Control
- Light Dimmers
- VAR Generators

Ordering Information

Example: Select the complete nine or ten digit part number you desire from the table - i.e. C430NX555 is a 800 Volt, 760 Ampere Phase Control SCR.

| Type | Voltage | | Current |
|------------|--------------------------------------|------|---------|
| | V _{ORM} V _{RRM} | Code | |
| C430__X555 | 500 | E | 760 |
| | 600 | M | |
| | 700 | S | |
| | 800 | N | |
| | 900 | T | |
| | 1000 | P | |
| | 1100 | PA | |
| | 1200 | PB | |
| | 1300 | PC | |



Powerex, Inc., Hillis Street, Youngwood, Pennsylvania 15697 (412) 925-7272

Powerex Europe, S.A., 428 Ave. G. Durand, BP107, 72003 LeMans, France (43) 72.75.15

C430_X555

Phase Control SCR

760 Amperes Avg/500-1300 Volts

Absolute Maximum Ratings

| | Symbol | C430_X555 | Units |
|---|--------------|-------------|--------------------|
| RMS On-State Current | $I_{T(RMS)}$ | 1200 | Amperes |
| Average On-State Current | $I_{T(av)}$ | 760 | Amperes |
| Peak One-Cycle Surge (Non-Repetitive) On-State Current (60Hz) | I_{TSM} | 8000 | Amperes |
| Peak One-Cycle Surge (Non-Repetitive) On-State Current (50Hz) | I_{TSM} | 7300 | Amperes |
| Critical Rate-of-Rise of On-State Current (Non-Repetitive) | di/dt | 400 | Amperes/ μ s |
| Critical Rate-of-Rise of On-State Current (Repetitive) | di/dt | 150 | Amperes/ μ s |
| I^2t (for Fusing), One Cycle at 60Hz | I^2t | 265,000 | A ² sec |
| Peak Gate Power Dissipation | P_{GM} | 200 | Watts |
| Average Gate Power Dissipation | $P_{G(av)}$ | 5 | Watts |
| Storage Temperature | T_{STG} | -40 to 150 | °C |
| Operating Temperature | T_J | -40 to 150 | °C |
| Mounting Force [Ⓞ] | | 800 to 2500 | lb. |
| Mounting Force [Ⓞ] | | 3.6 to 11.1 | KN |

Electrical and Thermal Characteristics

| Characteristics | Symbol | Test Conditions | C430_X555 | Units |
|---|-----------------|--|-----------|--------------------|
| Voltage—Blocking State Maximums[Ⓞ] | | | | |
| Forward Leakage, Peak | I_{DRM} | $T_J = 150^\circ\text{C}, V = V_{DRM}$ | 50 | mA |
| Reverse Leakage, Peak | I_{RRM} | $T_J = 150^\circ\text{C}, V = V_{RRM}$ | 50 | mA |
| Current—Conducting State Maximums | | | | |
| Peak On-State Voltage (2000 lb.) | V_{TM} | $I_{TM} = 3000\text{A Peak}, T_C = 25^\circ\text{C},$ Duty Cycle $\leq 0.01\%$ | 2.4 | Volts |
| Peak On-State Voltage (800 lb.) | V_{TM} | $I_{TM} = 3000\text{A Peak}, T_C = 25^\circ\text{C},$ Duty Cycle $\leq 0.01\%$ | 2.53 | Volts |
| Switching | | | | |
| Typical Turn-Off Time | t_d | $T_J = 150^\circ\text{C}, I_{TM} = 1000\text{A}, V_R = 50\text{V Min};$ V_{DRM} (Reapplied); Reapplied $dv/dt = 200\text{V}/\mu\text{sec}$ (linear); Commutation $di/dt = 25\text{A}/\mu\text{sec};$ Repetition Rate = 1pps, Gate Bias during Turn-Off Interval = 0V, 100 Ω | 100 | μsec |
| Typical Delay Time | t_d | $T_C = 25^\circ\text{C}, I_T = 50\text{A},$ Gate Supply: 20V, 20 Ω , 0.1 μsec rise time | .7 | μsec |
| Min. Critical dv/dt exponential to V_{DRM} | dv/dt | $T_J = 150^\circ\text{C},$ gate open | 100 | V/ μsec |
| Thermal and Mechanical | | | | |
| Maximum Thermal Resistance [Ⓞ] double sided cooling | | | | |
| Junction to Case (2000 lb. force) | $R_{\theta JC}$ | | .045 | °C/Watt |
| Case to Sink, Lubricated (2000 lb. force) | $R_{\theta CS}$ | | .02 | °C/Watt |
| Gate—Maximum Parameters | | | | |
| Gate Current to Trigger | I_{GT} | $V_D = 6\text{Vdc}, R_L = 3\text{ ohms}, T_J = 150^\circ\text{C}$ | 150 | mA |
| Gate Voltage to Trigger | V_{GT} | $V_D = 6\text{Vdc}, T_J = -40\text{ to }150^\circ\text{C}$ | 5 | Volts |
| Non-Triggering Gate Voltage | V_{GDM} | | .15 | Volts |
| Peak Forward Gate Current | I_{GTM} | | 10 | Amperes |
| Peak Reverse Gate Voltage | V_{GRM} | | 5 | Volts |

[Ⓞ] Consult recommended mounting procedures.



Powerex, Inc., Hillis Street, Youngwood, Pennsylvania 15697 (412) 925-7272
 Powerex Europe, S.A., 428 Ave. G. Durand, BP107, 72003 LeMans, France (43) 72.75.15

C430_X555
 Phase Control SCR
 760 Amperes Avg/500-1300 Volts

MAXIMUM ON-STATE CHARACTERISTICS

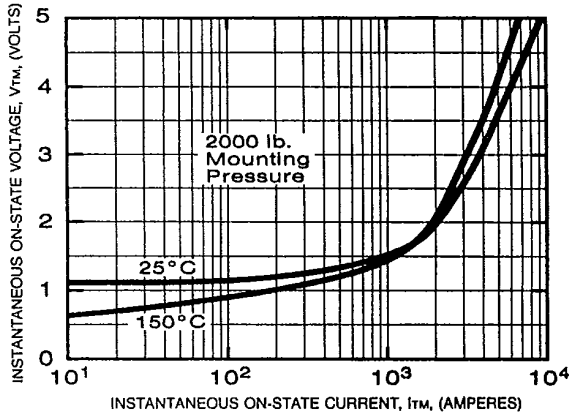

TRANSIENT THERMAL IMPEDANCE CHARACTERISTICS (JUNCTION TO CASE)

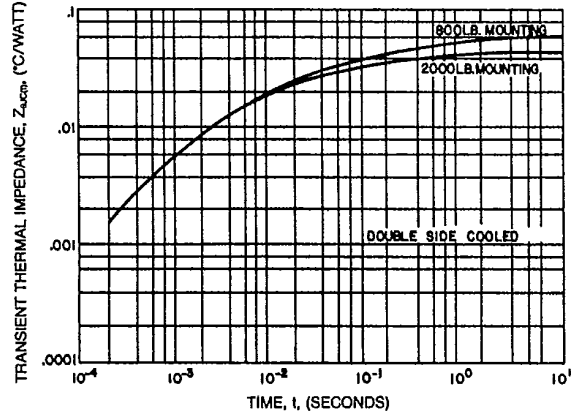

MAXIMUM ALLOWABLE CASE TEMPERATURE (SINUSOIDAL WAVEFORM)

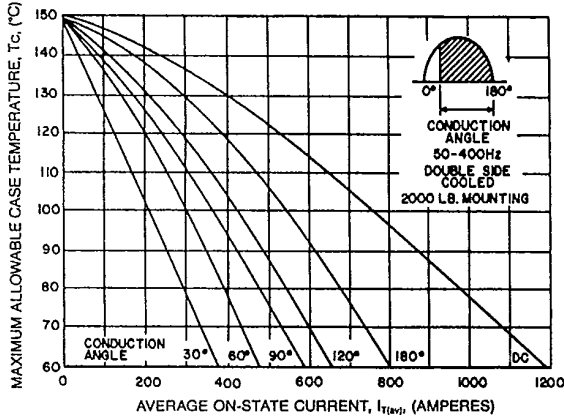

MAXIMUM ON-STATE POWER DISSIPATION (SINUSOIDAL WAVEFORM)

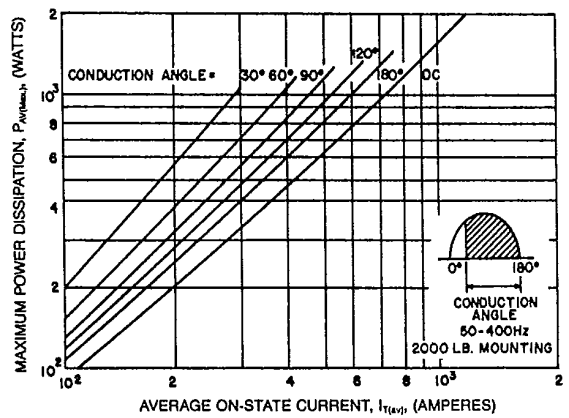

MAXIMUM ALLOWABLE CASE TEMPERATURE (RECTANGULAR WAVEFORM)

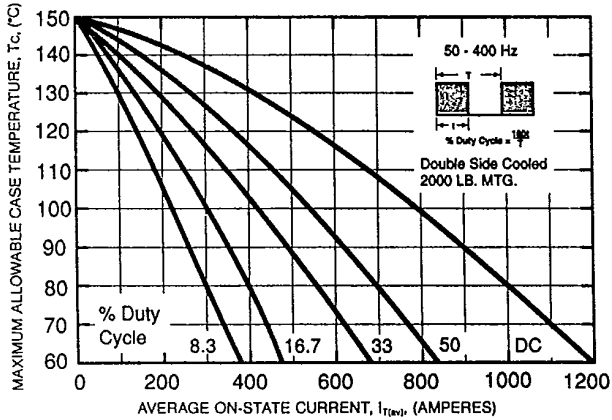

MAXIMUM ON-STATE POWER DISSIPATION (RECTANGULAR WAVEFORM)

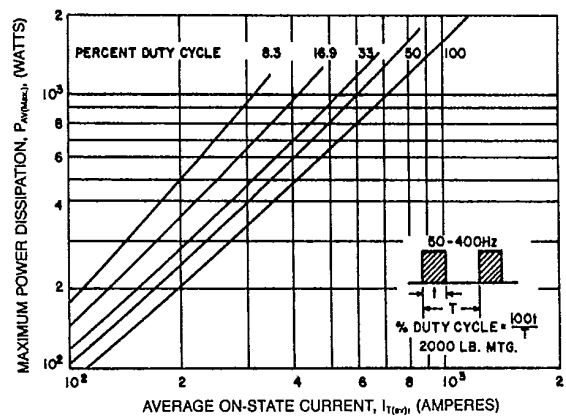



Powerex, Inc., Hillis Street, Youngwood, Pennsylvania 15697 (412) 925-7272

Powerex Europe, S.A., 428 Ave. G. Durand, BP107, 72003 LeMans, France (43) 72.75.15

C430_X555

Phase Control SCR

760 Amperes Avg/500-1300 Volts

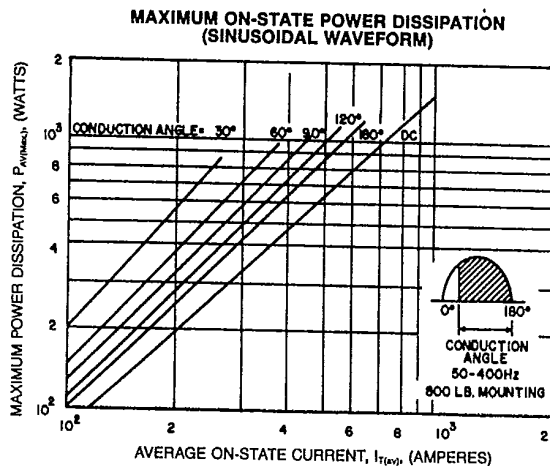
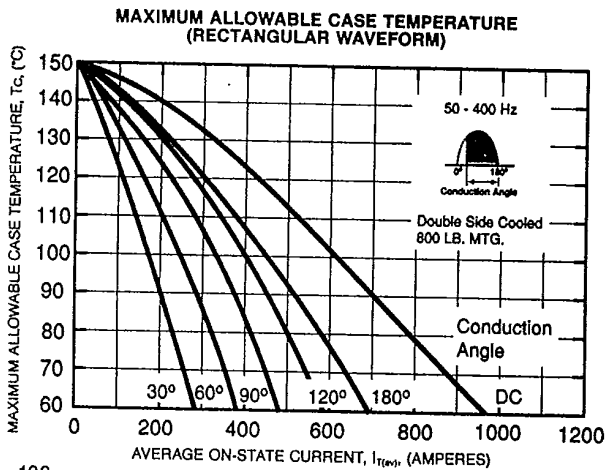
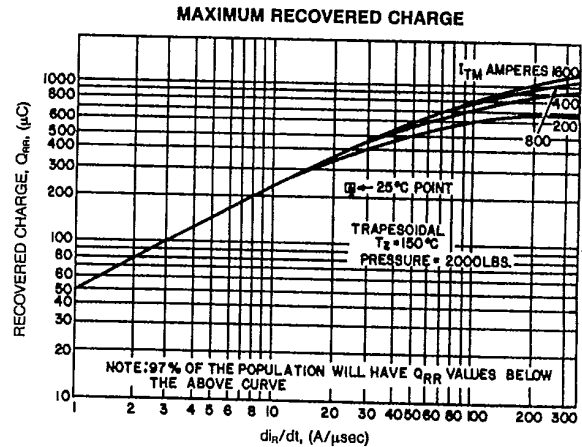
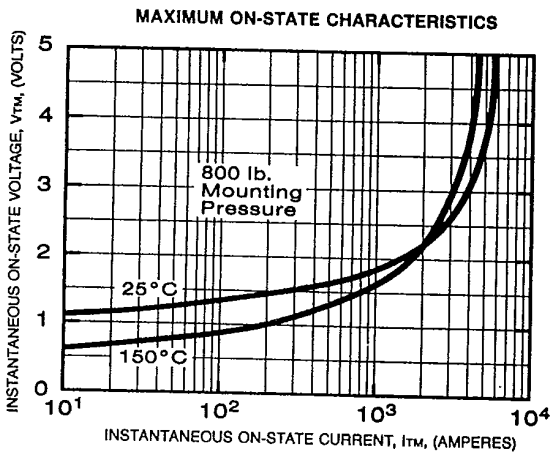
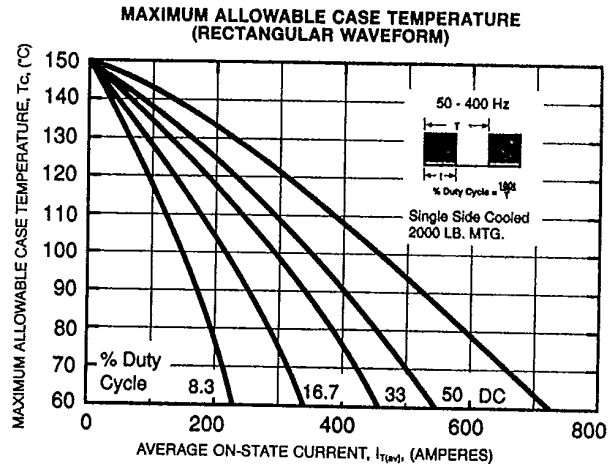
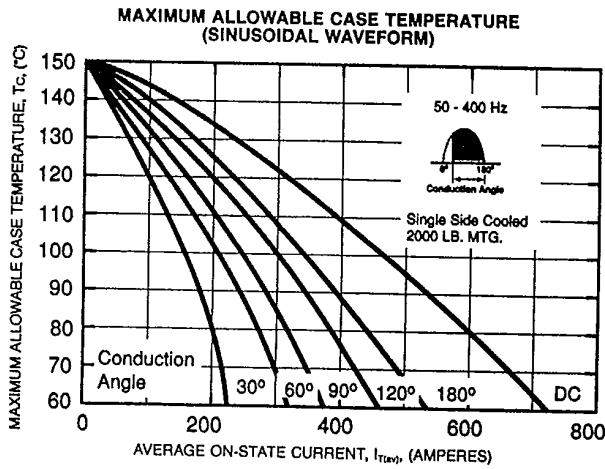



Powerex, Inc., Hillis Street, Youngwood, Pennsylvania 15697 (412) 925-7272
 Powerex Europe, S.A., 428 Ave. G. Durand, BP107, 72003 LeMans, France (43) 72.75.15

C430_X555
 Phase Control SCR
 760 Amperes Avg/500-1300 Volts

MAXIMUM ALLOWABLE CASE TEMPERATURE (SINUSOIDAL WAVEFORM)

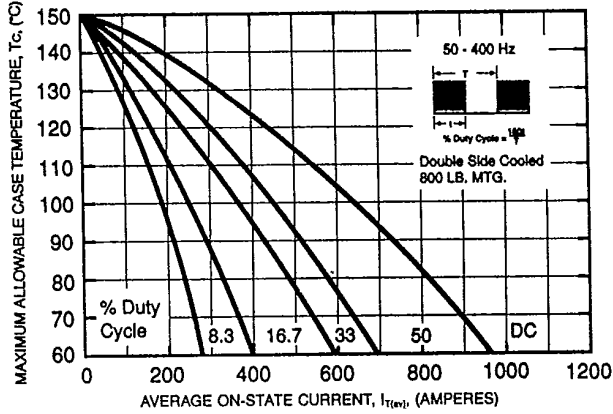

MAXIMUM ON-STATE POWER DISSIPATION (RECTANGULAR WAVEFORM)

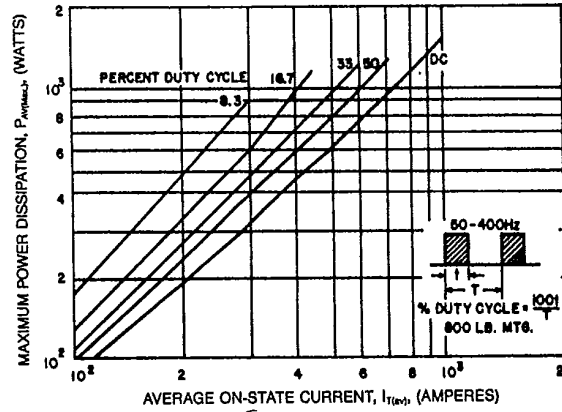

MAXIMUM ALLOWABLE CASE TEMPERATURE (SINUSOIDAL WAVEFORM)

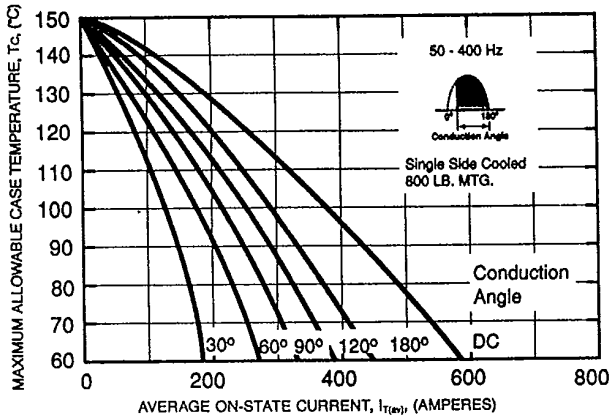

MAXIMUM ALLOWABLE CASE TEMPERATURE (RECTANGULAR WAVEFORM)

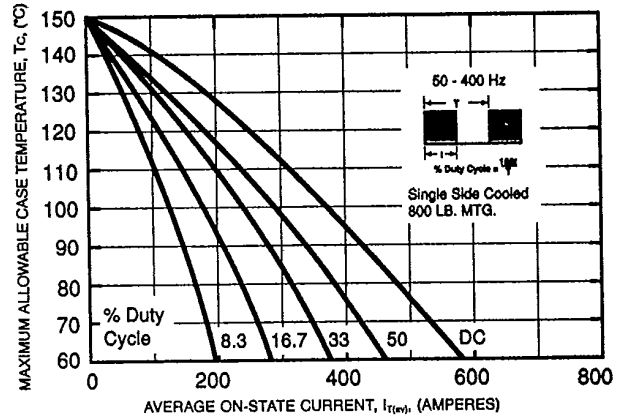



Powerex, Inc., Hillis Street, Youngwood, Pennsylvania 15697 (412) 925-7272
 Powerex Europe, S.A., 428 Ave. G. Durand, BP107, 72003 LeMans, France (43) 72.75.15

C430-X555
 Phase Control SCR
 760 Amperes Avg/500-1300 Volts

SUB-CYCLE SURGE AND I^2t RATINGS
 (RATED LOAD CONDITIONS)

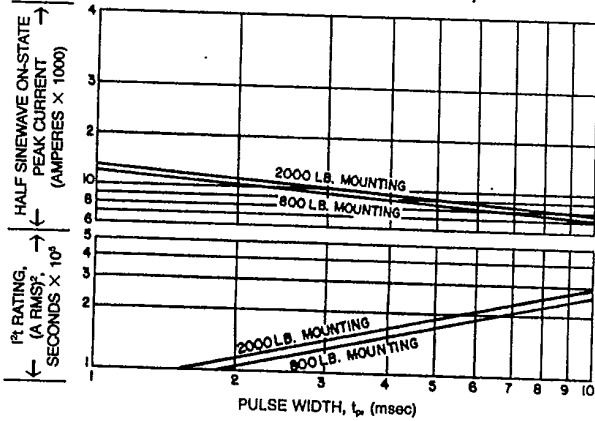

GATE CHARACTERISTICS

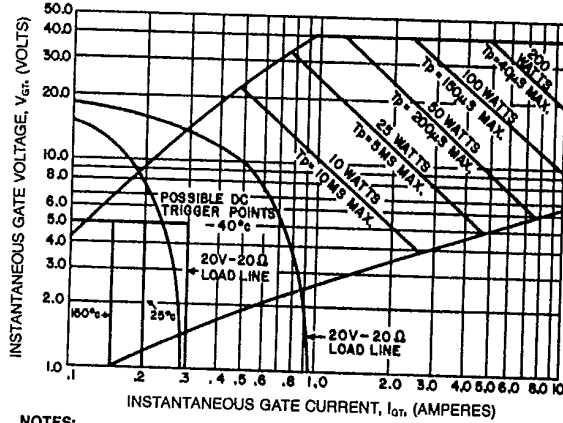

NOTES:

1. Maximum allowable average gate dissipation = 5 watts.
 2. The locus of possible dc trigger points lie outside the boundaries shown at various case temperatures.
 3. T_p = Rectangular gate current pulse width (5 μs min. duration; 1.0 μs max. rise time for 20V, 65 Ω source).
 4. 20V - 20 Ω is the minimum gate source load line when rate of circuit current rise > 100 Amp/ μs or anode rate of current rise > 200 Amps/ μs (T_p = 5 μs min., 0.5 μs max. rise time).
- Maximum long-term repetitive anode di/dt = 500 Amps/ μs with 20V - 20 Ω gate source.



LittleDiode supplies new, hard to find or obsolete electronic components and semiconductors all over the world.

With over two million different components listed you are sure to find the part you need.

Feel free to visit us today at our online store:

LittleDiode.com

Looking forward to providing you with the best possible service.