

SIMOPAC® Module

BSM 181 BSM 181 R

$$V_{DS} = 100 \text{ V}$$

$$I_D = 200 \text{ A}$$

$$R_{DS(on)} = 8.5 \text{ m}\Omega$$

- Power module
- Single switch
- N channel
- Enhancement mode
- Package with insulated metal base plate
- Package outline/Circuit diagram: 1¹⁾

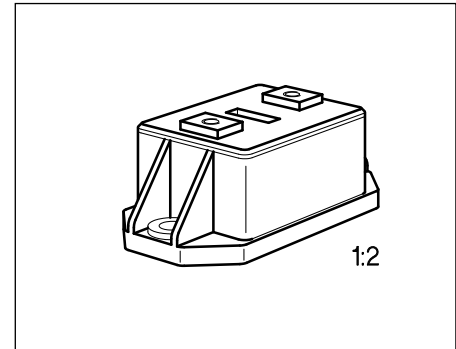

Type	Ordering Code
BSM 181	C67076-A1001-A2
BSM 181 R	C67076-A1016-A2

Maximum Ratings

Parameter	Symbol	Values	Unit
Drain-source voltage	V_{DS}	800	V
Drain-gate voltage, $R_{GS} = 20 \text{ k}\Omega$	V_{DGR}	800	
Gate-source voltage	V_{GS}	± 20	
Continuous drain current, $T_C = 25 \text{ }^\circ\text{C}$	I_D	36	A
Pulsed drain current, $T_C = 25 \text{ }^\circ\text{C}$	$I_{D \text{ puls}}$	144	
Operating and storage temperature range	T_j, T_{stg}	$-55 \dots +150$	$^\circ\text{C}$
Power dissipation, $T_C = 25 \text{ }^\circ\text{C}$	P_{tot}	700	W
Thermal resistance Chip-case	$R_{th \text{ JC}}$	≤ 0.18	K/W
Insulation test voltage ²⁾ , $t = 1 \text{ min.}$	V_{is}	2500	V_{ac}
Creepage distance, drain-source	–	16	mm
Clearance, drain-source	–	11	
DIN humidity category, DIN 40 040	–	F	–
IEC climatic category, DIN IEC 68-1	–	55/150/56	

1) See chapter Package Outline and Circuit Diagrams.

2) Insulation test voltage between drain and base plate referred to standard climate 23/50 in acc. with DIN 50 014, IEC 146, para. 492.1.

Electrical Characteristics

at $T_j = 25\text{ °C}$, unless otherwise specified.

Parameter	Symbol	Values			Unit
		min.	typ.	max.	

Static Characteristics

Drain-source breakdown voltage $V_{GS} = 0, I_D = 0.25\text{ mA}$	$V_{(BR)DSS}$	800	–	–	V
Gate threshold voltage $V_{DS} = V_{GS}, I_D = 1\text{ mA}$	$V_{GS(th)}$	2.1	3.0	4.0	
Zero gate voltage drain current $V_{DS} = 800\text{ V}, V_{GS} = 0$ $T_j = 25\text{ °C}$ $T_j = 125\text{ °C}$	I_{DSS}	– –	50 300	250 1000	μA
Gate-source leakage current $V_{GS} = 20\text{ V}, V_{DS} = 0$	I_{GSS}	–	10	100	nA
Drain-source on-state resistance $V_{GS} = 10\text{ V}, I_D = 23\text{ A}$	$R_{DS(on)}$	–	0.18	0.24	Ω

Dynamic Characteristics

Forward transconductance $V_{DS} \geq 2 \times I_D \times R_{DS(on)max.}, I_D = 23\text{ A}$	g_{fs}	15	25	–	S
Input capacitance $V_{GS} = 0, V_{DS} = 25\text{ V}, f = 1\text{ MHz}$	C_{iss}	–	24	32	nF
Output capacitance $V_{GS} = 0, V_{DS} = 25\text{ V}, f = 1\text{ MHz}$	C_{oss}	–	1.3	2.0	
Reverse transfer capacitance $V_{GS} = 0, V_{DS} = 25\text{ V}, f = 1\text{ MHz}$	C_{rss}	–	0.5	0.8	
Turn-on time t_{on} ($t_{on} = t_{d(on)} + t_r$) $V_{CC} = 400\text{ V}, V_{GS} = 10\text{ V}$ $I_D = 23\text{ A}, R_{GS} = 3.3\text{ }\Omega$	$t_{d(on)}$	–	60	–	ns
	t_r	–	30	–	
Turn-off time t_{off} ($t_{off} = t_{d(off)} + t_f$) $V_{CC} = 400\text{ V}, V_{GS} = 10\text{ V}$ $I_D = 23\text{ A}, R_{GS} = 3.3\text{ }\Omega$	$t_{d(off)}$	–	370	–	
	t_f	–	70	–	

Electrical Characteristics (cont'd)

at $T_j = 25\text{ °C}$, unless otherwise specified.

Parameter	Symbol	Values			Unit
		min.	typ.	max.	

Reverse diode

Continuous reverse drain current $T_C = 25\text{ °C}$	I_S	–	–	36	A
Pulsed reverse drain current $T_C = 25\text{ °C}$	I_{SM}	–	–	144	
Diode forward on-voltage $I_F = 72\text{ A}$, $V_{GS} = 0$	V_{SD}	–	1.1	1.4	V
Reverse recovery time $I_F = I_S$, $di_F/dt = 100\text{ A}/\mu\text{s}$, $V_R = 100\text{ V}$ $T_j = 25\text{ °C}$ $T_j = 150\text{ °C}$	t_{rr}	– –	1200 –	– –	ns
Reverse recovery charge $I_F = I_S$, $di_F/dt = 100\text{ A}/\mu\text{s}$, $V_R = 100\text{ V}$ $T_j = 25\text{ °C}$ $T_j = 150\text{ °C}$	Q_{rr}	– –	42 50	– –	μC

Characteristics at $T_j = 25\text{ }^\circ\text{C}$, unless otherwise specified.

Power dissipation $P_{\text{tot}} = f(T_c)$
parameter: $T_j = 150\text{ }^\circ\text{C}$

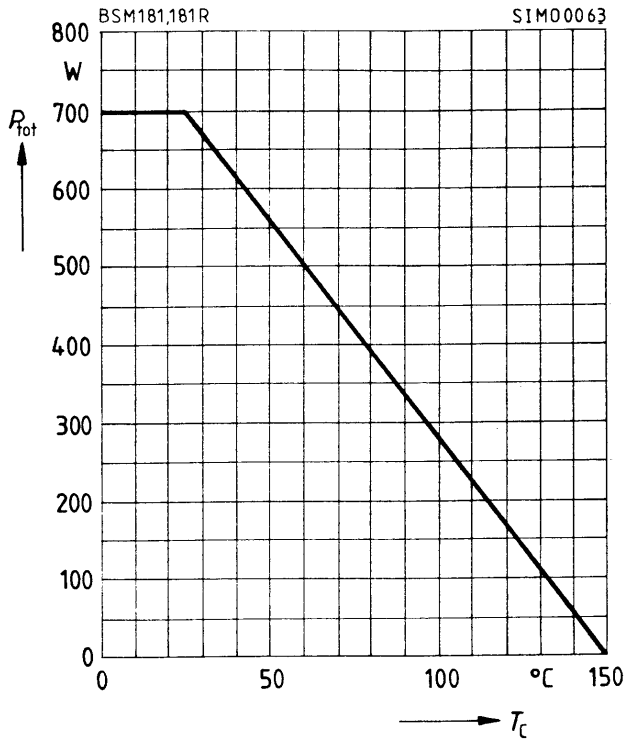

Typ. output characteristics $I_D = f(V_{\text{DS}})$
parameter: $t_p = 80\text{ }\mu\text{s}$ pulse test

Safe operating area $I_D = f(V_{\text{DS}})$
parameter: single pulse, $T_c = 25\text{ }^\circ\text{C}$,
 $T_j \leq 150\text{ }^\circ\text{C}$

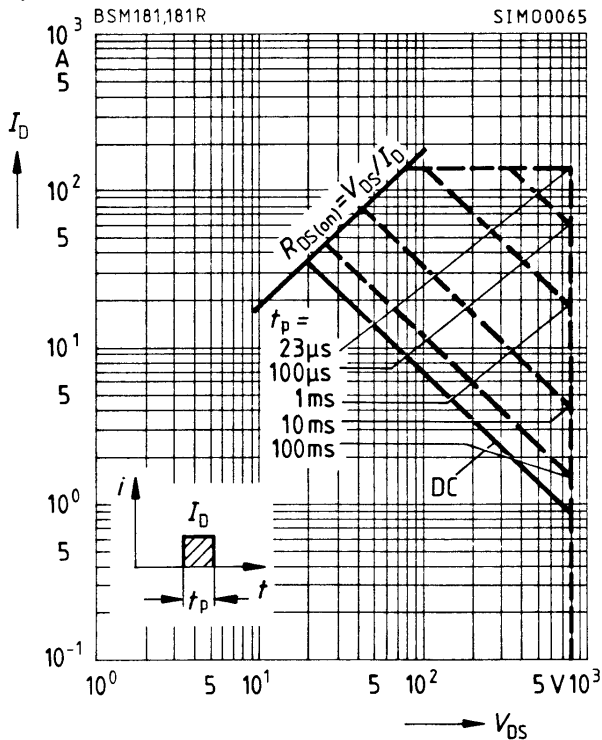

Typ. transfer characteristic $I_D = f(V_{\text{GS}})$
parameter: $t_p = 80\text{ }\mu\text{s}$, $V_{\text{DS}} = 25\text{ V}$

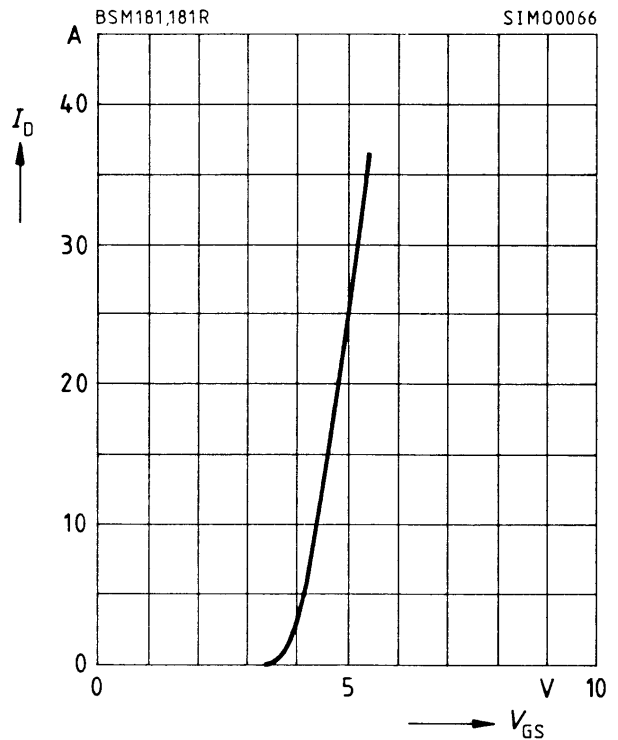

Continuous drain current

$$I_D = f(T_C)$$

parameter: $V_{GS} \geq 10 \text{ V}$, $T_j = 150 \text{ }^\circ\text{C}$

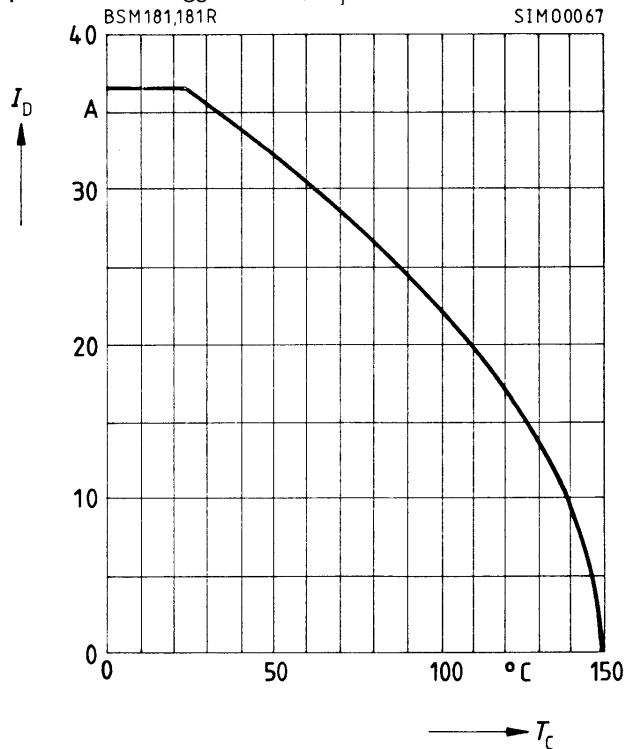

Drain-source breakdown voltage

$$V_{(BR)DSS}(T_j) = b \times V_{(BR)DSS}(25 \text{ }^\circ\text{C})$$

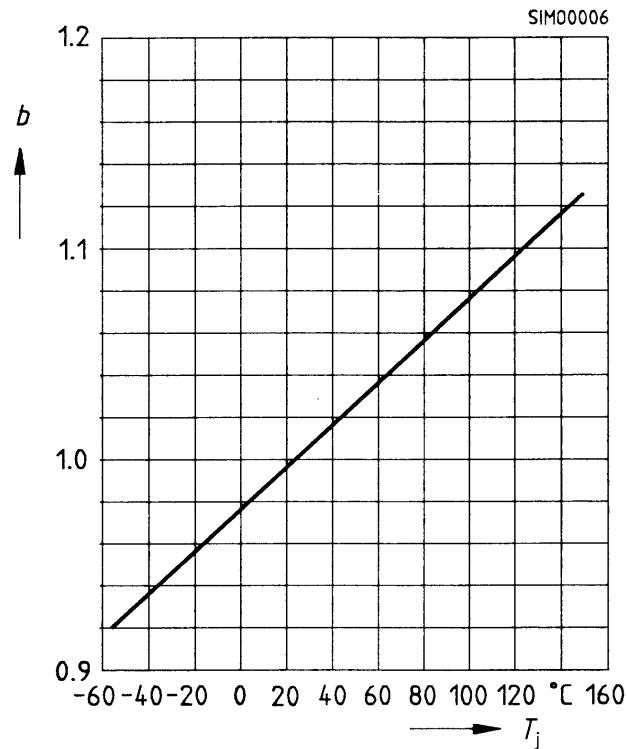

Drain source on-state resistance

$$R_{DS(on)} = f(T_j)$$

parameter: $I_D = 36 \text{ A}$; $V_{GS} = 10 \text{ V}$, (spread)

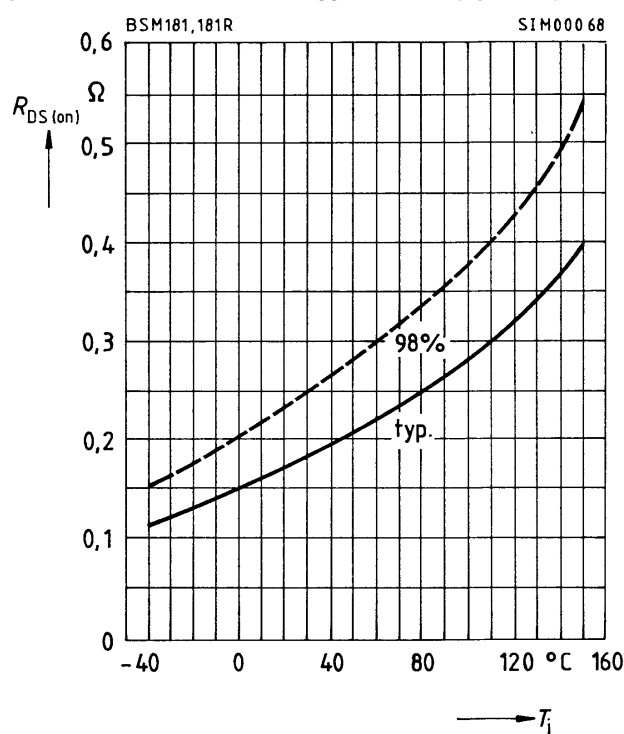

Typical capacitances $C = f(V_{DS})$

parameter: $V_{GS} = 0$, $f = 1 \text{ MHz}$

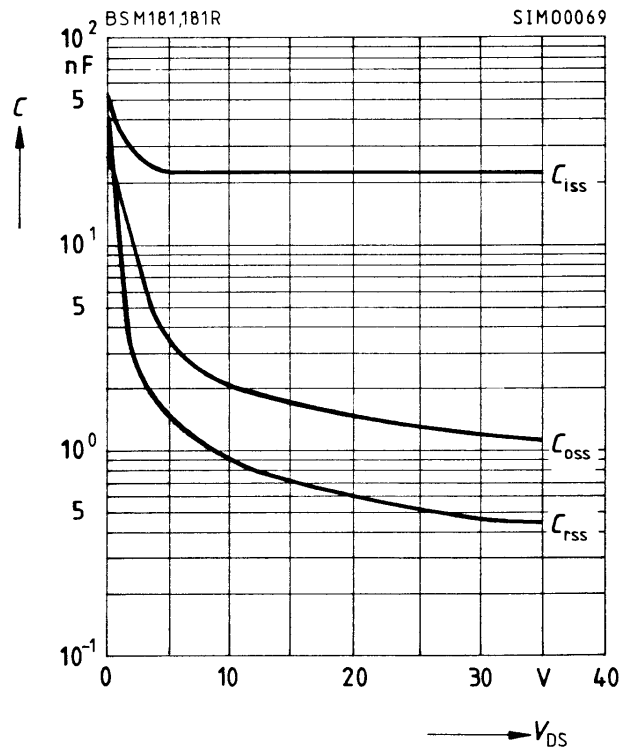

Forward characteristics of

reverse diode $I_F = f(V_{SD})$

parameter: $T_j, t_p = 80 \mu s$ (spread)

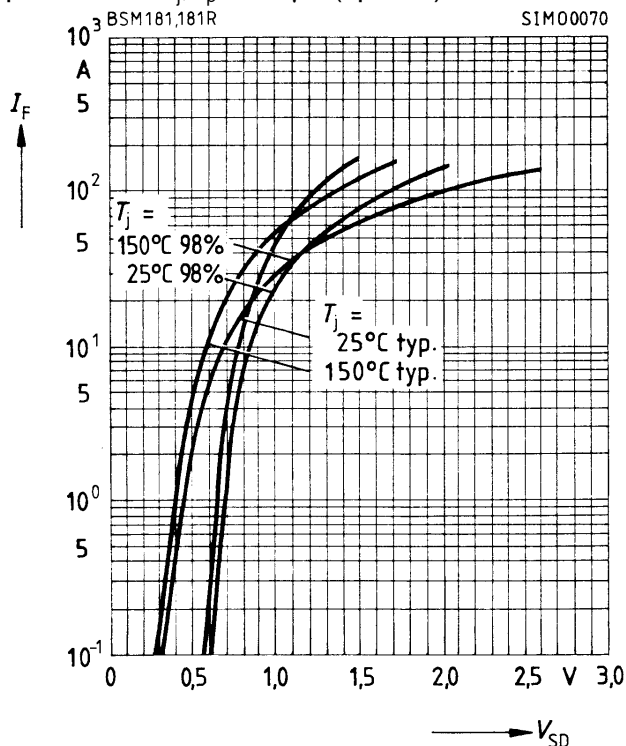

Transient thermal impedance $Z_{thJC} = f(t_p)$

parameter: $D = t_p/T$

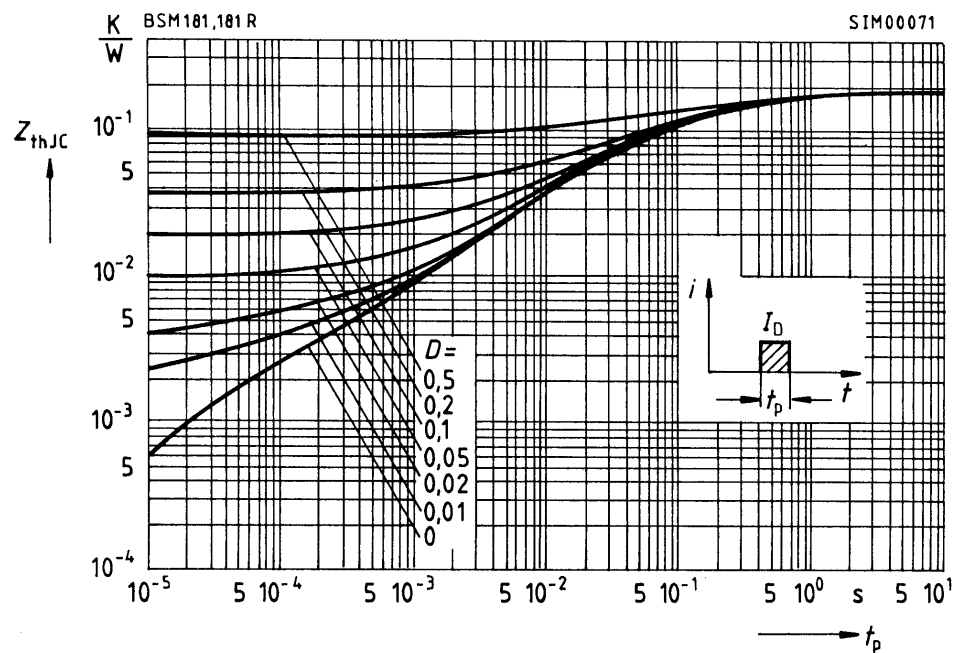

Typ. gate charge $V_{GS} = f(Q_{Gate})$
parameter: $I_{Dpuls} = 52.5 A$

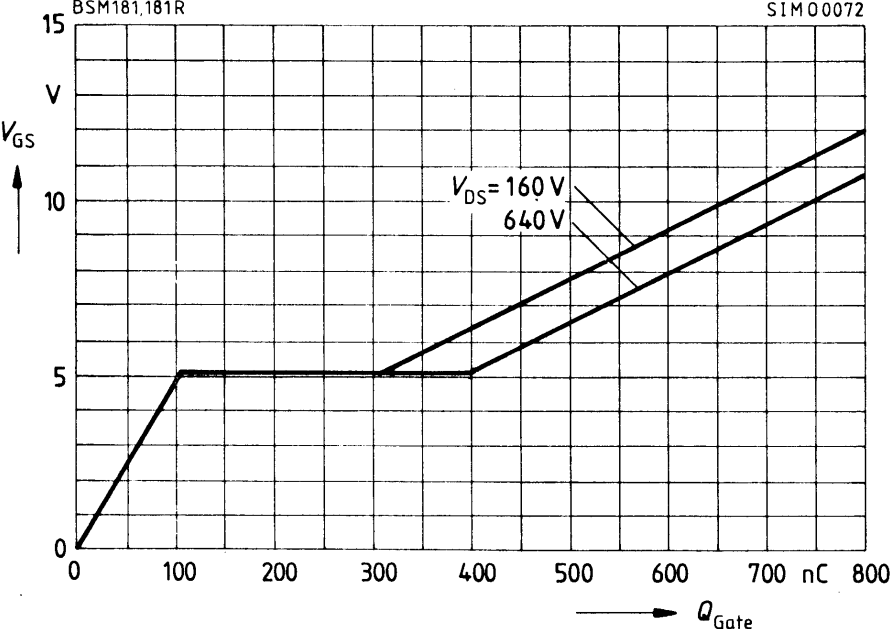



LittleDiode supplies new, hard to find or obsolete electronic components and semiconductors all over the world.

With over two million different components listed you are sure to find the part you need.

Feel free to visit us today at our online store:

LittleDiode.com

Looking forward to providing you with the best possible service.