

$$V_{DS} = 50 \text{ V}$$

$$I_D = 200 \text{ A}$$

$$R_{DS(on)} = 3.0 \text{ m}\Omega$$

- Power module
- Single switch
- N channel
- Enhancement mode
- Package with insulated metal base plate
- Package outline/Circuit diagram: 1<sup>1)</sup>

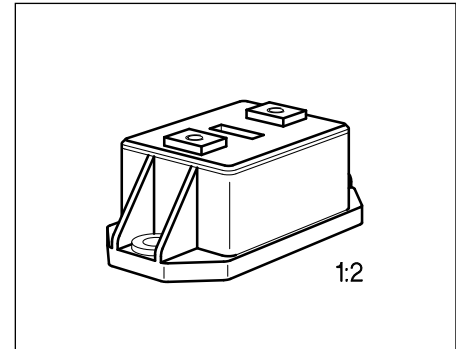

Type	Ordering Code
BSM 101 AR	C67076-S1018-A2

### Maximum Ratings

Parameter	Symbol	Values	Unit
Drain-source voltage	$V_{DS}$	50	V
Drain-gate voltage, $R_{GS} = 20 \text{ k}\Omega$	$V_{DGR}$	50	
Gate-source voltage	$V_{GS}$	$\pm 20$	
Continuous drain current, $T_C = 105 \text{ }^\circ\text{C}$	$I_D$	200	A
Pulsed drain current, $T_C = 105 \text{ }^\circ\text{C}$	$I_{D \text{ puls}}$	600	
Operating and storage temperature range	$T_j, T_{stg}$	$- 55 \dots + 150$	$^\circ\text{C}$
Power dissipation, $T_C = 25 \text{ }^\circ\text{C}$	$P_{tot}$	700	W
Thermal resistance, chip-case	$R_{thJC}$	$\leq 0.18$	K/W
Insulation test voltage <sup>2)</sup> , $t = 1 \text{ min.}$	$V_{is}$	2500	$V_{ac}$
Creepage distance, drain-source	–	16	mm
Clearance, drain-source	–	11	
DIN humidity category, DIN 40 040	–	F	–
IEC climatic category, DIN IEC 68-1	–	55/150/56	–

<sup>1)</sup> See chapter Package Outline and Circuit Diagrams.

<sup>2)</sup> Insulation test voltage between drain and base plate referred to standard climate 23/50 in acc. with DIN 50 014, IEC 146, para. 492.1.

## Electrical Characteristics

at  $T_j = 25\text{ °C}$ , unless otherwise specified.

Parameter	Symbol	Values			Unit
		min.	typ.	max.	

## Static Characteristics

Drain-source breakdown voltage $V_{GS} = 0, I_D = 0.25\text{ mA}$	$V_{(BR)DSS}$	50	–	–	V
Gate threshold voltage $V_{GS} = V_{DS}, I_D = 1\text{ mA}$	$V_{GS(th)}$	2.1	3.0	4.0	
Zero gate voltage drain current $V_{DS} = 50\text{ V}, V_{GS} = 0$ $T_j = 25\text{ °C}$ $T_j = 125\text{ °C}$	$I_{DSS}$	– –	50 300	250 1000	$\mu\text{A}$
Gate-source leakage current $V_{GS} = 20\text{ V}, V_{DS} = 0$	$I_{GSS}$	–	10	100	nA
Drain-source on-state resistance $V_{GS} = 10\text{ V}, I_D = 200\text{ A}$	$R_{DS(on)}$	–	2.6	3.0	m $\Omega$

## Dynamic Characteristics

Forward transconductance $V_{DS} \geq 2 \times I_D \times R_{DS(on)\text{ max.}}, I_D = 200\text{ A}$	$g_{fs}$	156	200	–	S
Input capacitance $V_{GS} = 0, V_{DS} = 25\text{ V}, f = 1\text{ MHz}$	$C_{iss}$	–	18	24	nF
Output capacitance $V_{GS} = 0, V_{DS} = 25\text{ V}, f = 1\text{ MHz}$	$C_{oss}$	–	9	12	
Reverse transfer capacitance $V_{GS} = 0, V_{DS} = 25\text{ V}, f = 1\text{ MHz}$	$C_{rss}$	–	3	4	
Turn-on Time $t_{on}$ ( $t_{on} = t_{d(on)} + t_r$ ) $V_{CC} = 40\text{ V}, V_{GS} = 10\text{ V}$ $I_D = 200\text{ A}, R_G = 3.3\text{ }\Omega$	$t_{d(on)}$	–	280	–	ns
	$t_r$	–	220	–	
Turn-off Time $t_{off}$ ( $t_{off} = t_{d(off)} + t_f$ ) $V_{CC} = 40\text{ V}, V_{GS} = 10\text{ V}$ $I_D = 200\text{ A}, R_G = 3.3\text{ }\Omega$	$t_{d(off)}$	–	220	–	
	$t_f$	–	60	–	

### Electrical Characteristics (cont'd)

at  $T_j = 25\text{ °C}$ , unless otherwise specified.

Parameter	Symbol	Values			Unit
		min.	typ.	max.	

### Reverse diode

Continuous reverse drain current $T_C = 25\text{ °C}$	$I_S$	–	–	200	A
Pulsed reverse drain current $T_C = 25\text{ °C}$	$I_{SM}$	–	–	600	
Diode forward on-voltage $I_F = 400\text{ A}$ , $V_{GS} = 0$	$V_{SD}$		1.25	1.6	V
Reverse recovery time $I_F = I_S$ , $di_F/dt = 100\text{ A}/\mu\text{s}$ , $V_R = 30\text{ V}$	$t_{rr}$		400	–	ns
Reverse recovery charge $I_F = I_S$ , $di_F/dt = 100\text{ A}/\mu\text{s}$ , $V_R = 30\text{ V}$	$Q_{rr}$		3.5		$\mu\text{C}$

Characteristics at  $T_j = 25^\circ\text{C}$ , unless otherwise specified.

**Power dissipation**  $P_{\text{tot}} = f(T_C)$   
parameter:  $T_j = 150^\circ\text{C}$

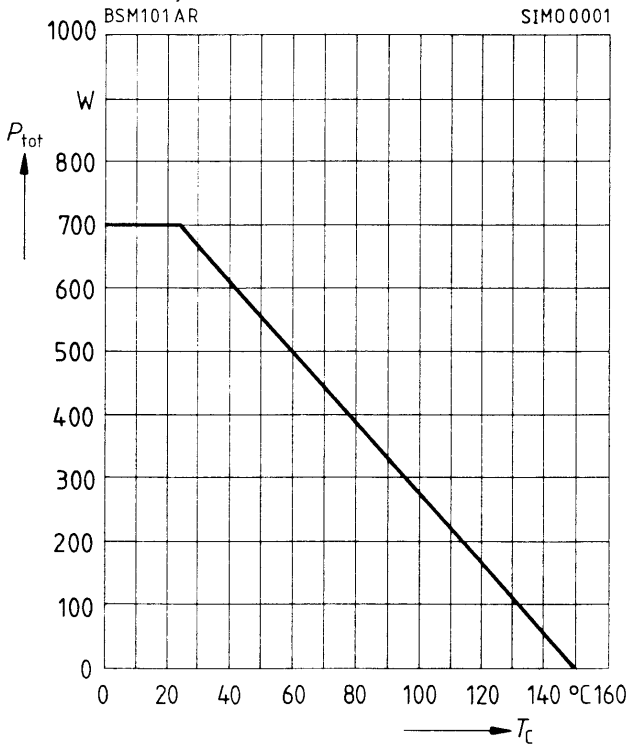

**Typ. output characteristics**  $I_D = f(V_{\text{DS}})$   
parameter: = 80  $\mu\text{s}$  pulse test

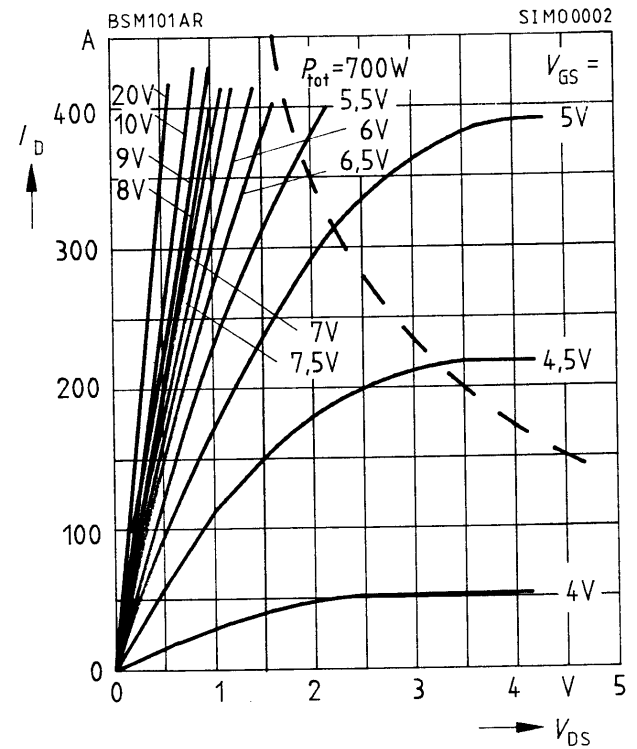

**Safe operating area**  $I_D = f(V_{\text{DS}})$   
parameter: single pulse,  $T_C = 25^\circ\text{C}$ ,  
 $T_j \leq 150^\circ\text{C}$

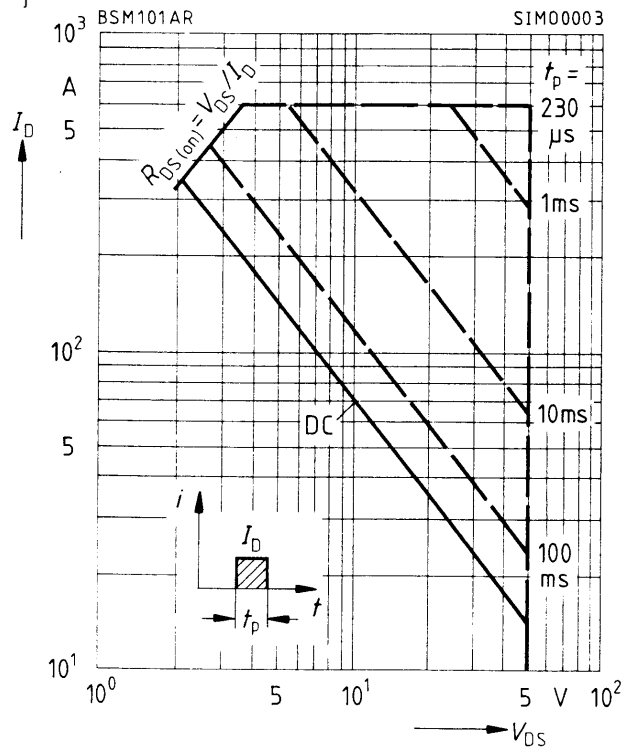

**Typ. transfer characteristic**  $I_D = f(V_{\text{GS}})$   
parameter: = 80  $\mu\text{s}$  pulse test,  $V_{\text{DS}} = 25\text{ V}$

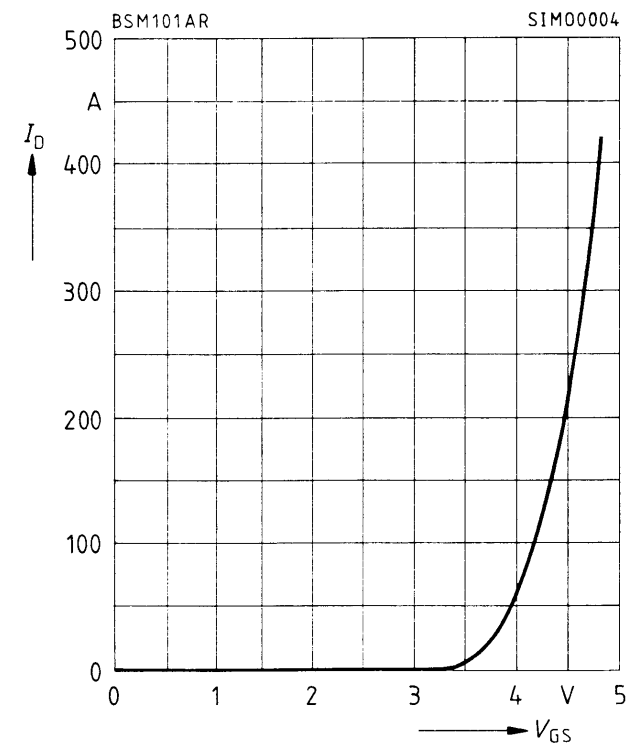

**Continuous drain-source current**

$I_D = f(T_C)$

parameter:  $V_{GS} \geq 10\text{ V}$ ,  $T_j = 150\text{ }^\circ\text{C}$

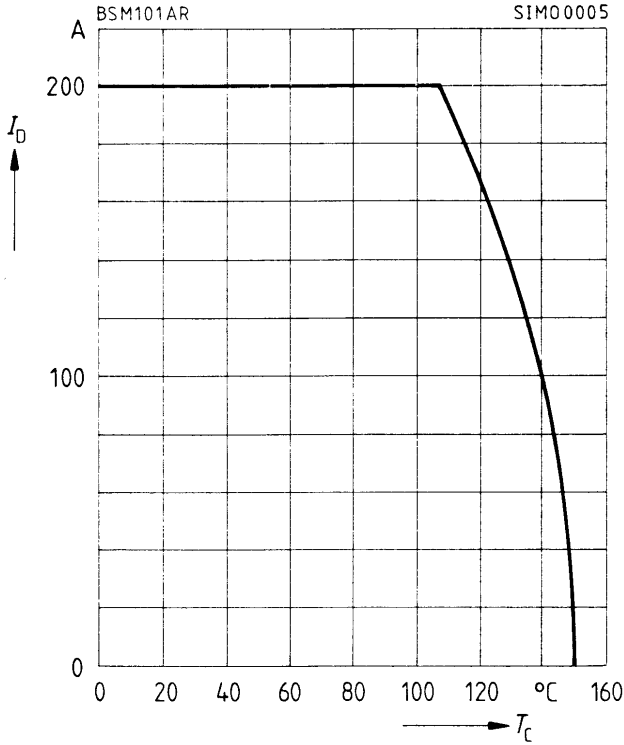

**Drain-source breakdown voltage**

$V_{(BR)DSS} = b \times V_{(BR)DSS}(25\text{ }^\circ\text{C})$

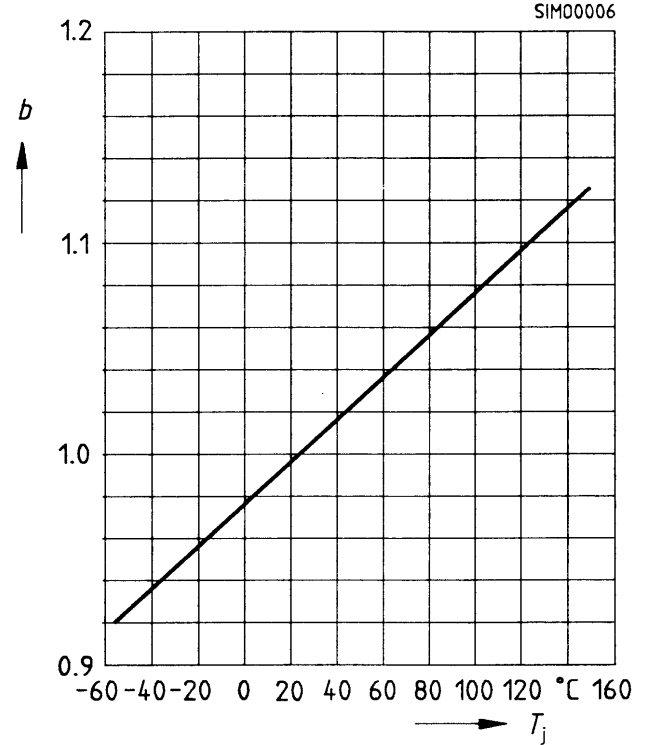

**Drain source on-state resistance**

$R_{DS(on)} = f(I_D)$

parameter:  $V_{GS}$

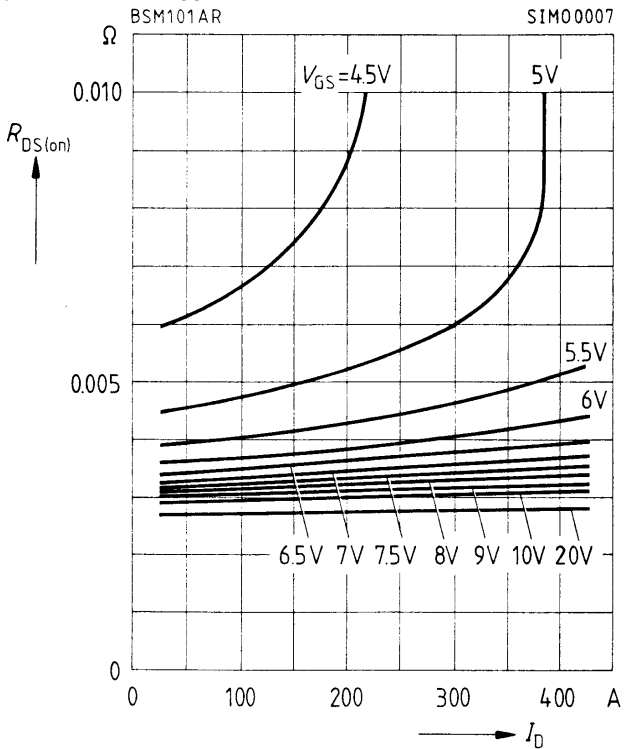

**Drain source on-state resistance**

$R_{DS(on)} = f(T_j)$

parameter:  $I_D = 200\text{ A}$ ;  $V_{GS} = 10\text{ V}$

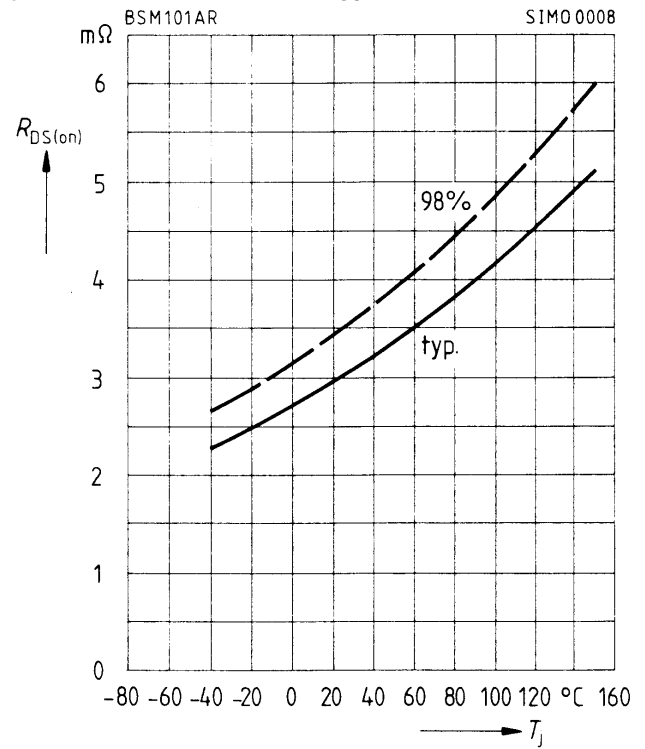

**Typ. capacitances  $C = f(V_{DS})$**   
 parameter:  $V_{GS} = 0, f = 1 \text{ MHz}$

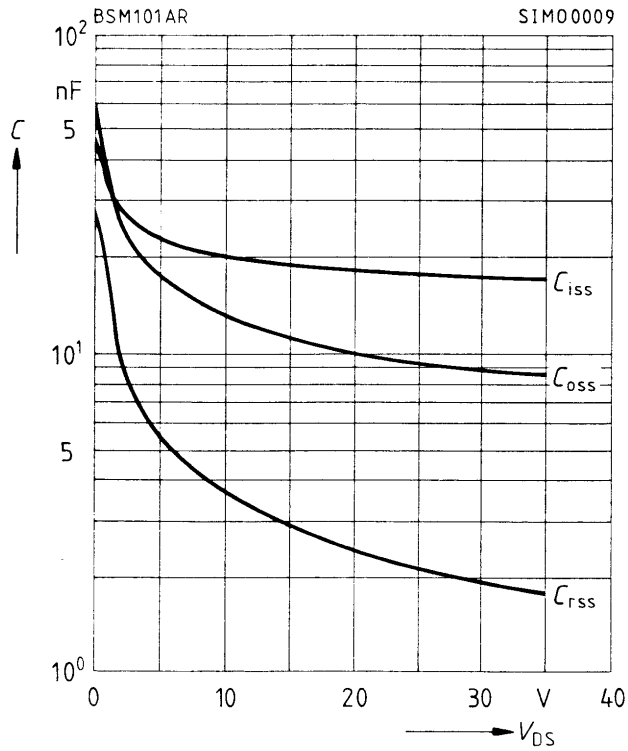

**Gate threshold voltage  $V_{GS(th)} = f(T_j)$**   
 parameter:  $V_{DS} = V_{GS}, I_D = 1 \text{ mA}$   
 (spread)

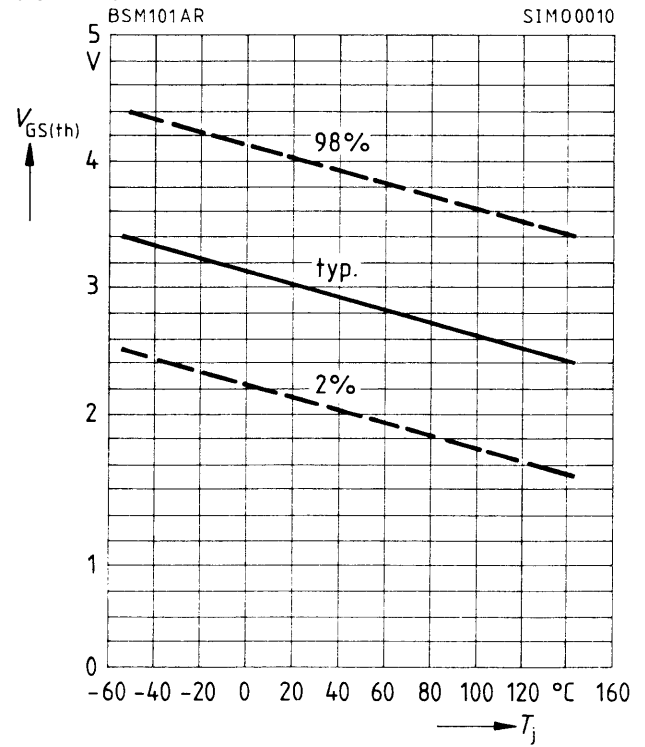

**Transient thermal impedance  $Z_{thJC} = f(t_p)$**

parameter:  $D = t_p/T$

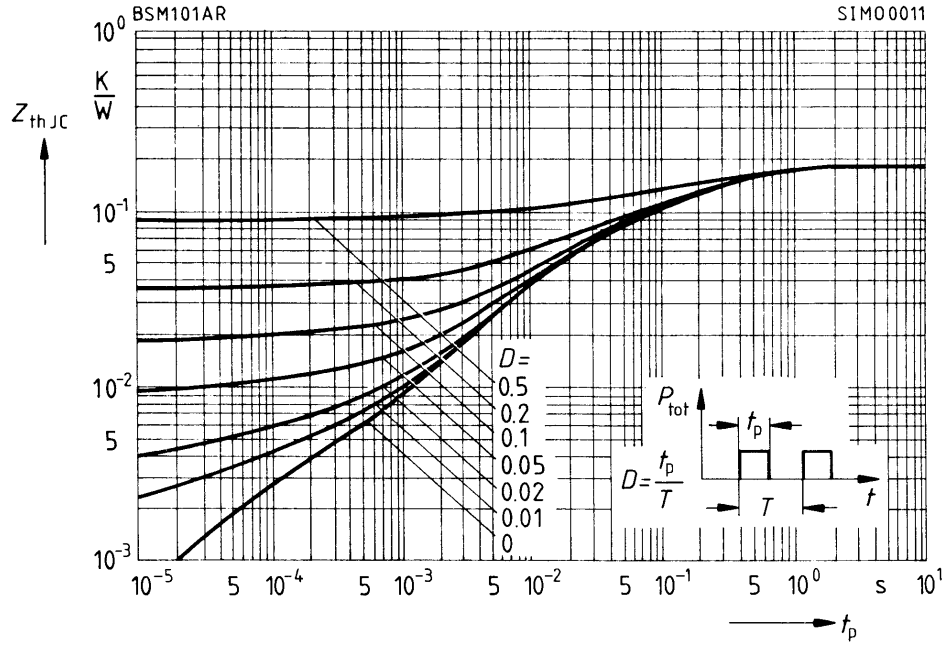

**Typ. gate charge  $V_{GS} = f(Q_{Gate})$**

parameter:  $I_{Dpuls} = 330$  A

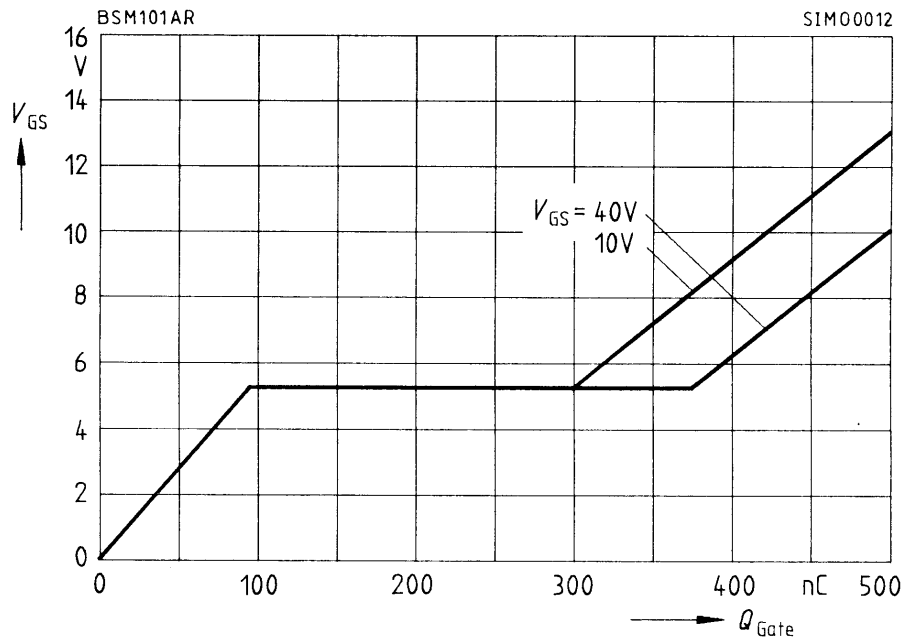



LittleDiode supplies new, hard to find or obsolete electronic components and semiconductors all over the world.

With over two million different components listed you are sure to find the part you need.

Feel free to visit us today at our online store:

[LittleDiode.com](http://LittleDiode.com)

Looking forward to providing you with the best possible service.