

# AN3328S

## 2-head recording and playback amplifier IC (A2) for HiFi VCR

### ■ Overview

The AN3328S is a 2-head recording and playback amplifier IC for HiFi audio, and realized reduction of pin numbers. The package is a small outline of 16 pins, 1.27 mm pitch and supply voltage is 5 V of single supply.

### ■ Features

- Damping-less amp. in playback system
- No adjustment of recording current by AGC
- 3-step switchover of recording current level with the current emphasis switch (typ.  $\pm 1.8$  dB)

### ■ Applications

- HiFi VCR

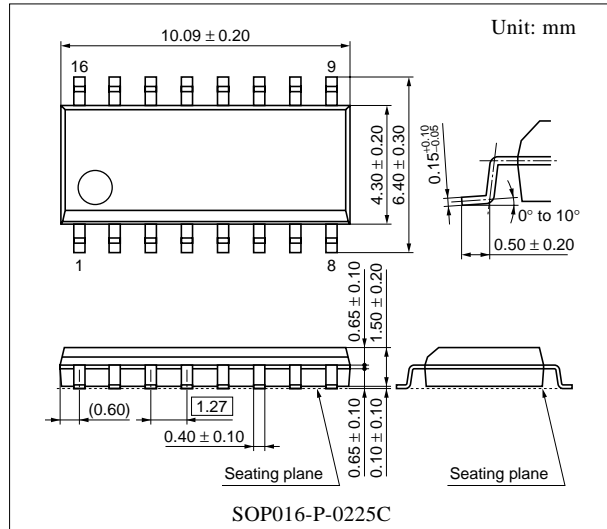

### ■ Block Diagram

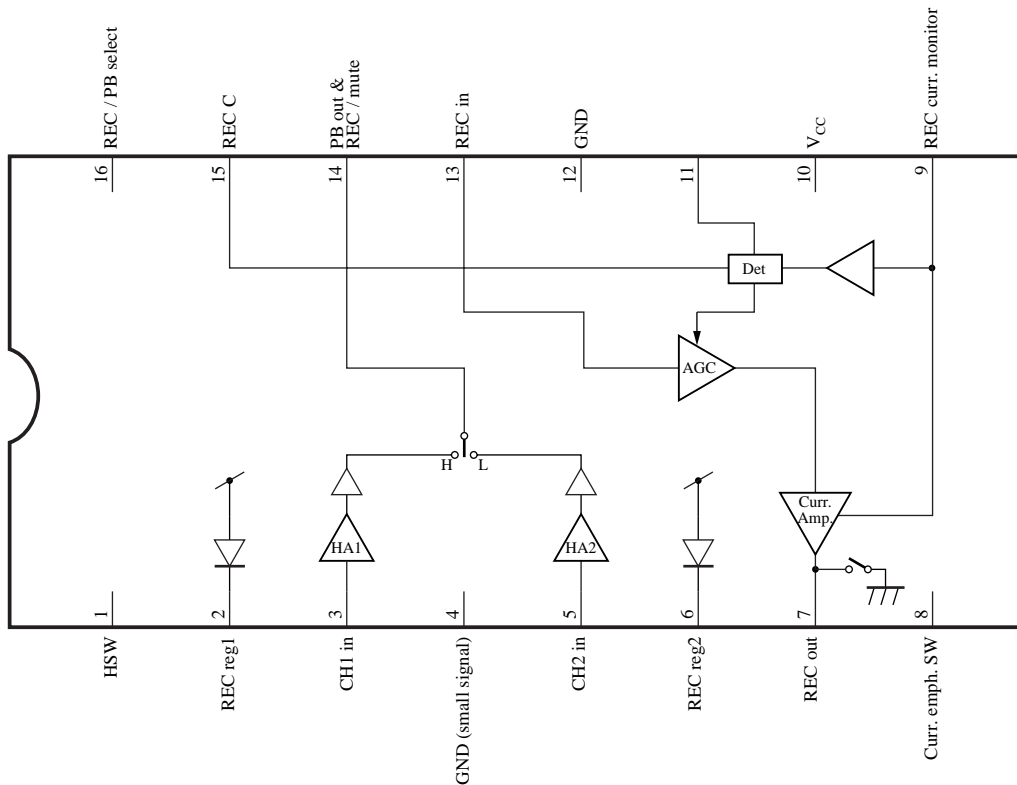

### ■ Pin Descriptions

Pin No.	Description	Pin No.	Description
1	Audio head SW	9	REC curr. monitor (control)
2	REC regulator1	10	V <sub>CC</sub>
3	Head amp. input ch.1	11	REC AGC det
4	GND (small signal)	12	GND
5	Head amp. input ch.2	13	REC input
6	REC regulator2	14	PB out & REC / mute SW
7	REC out	15	REC C
8	Curr. emph. SW	16	REC/PB select SW

### ■ Absolute Maximum Ratings

Parameter	Symbol	Rating	Unit
Supply voltage	V <sub>CC</sub>	6	V
Supply current	I <sub>CC</sub>	—	mA
Power dissipation*2	P <sub>D</sub>	240	mW
Operating ambient temperature*1	T <sub>opr</sub>	-20 to +70	°C
Storage temperature*1	T <sub>stg</sub>	-55 to +125	°C

Note) \*1: Except for the operating ambient temperature and storage temperature, all ratings are for T<sub>a</sub> = 25°C.

\*2: The power dissipation shown is for the IC package in free air at T<sub>a</sub> = 70°C.

### ■ Recommended Operating Range

Parameter	Symbol	Range	Unit
Supply voltage	V <sub>CC</sub>	4.5 to 5.5	V

■ Electrical Characteristics at  $T_a = 25^\circ\text{C}$

Parameter	Symbol	Conditions	Min	Typ	Max	Unit
REC Circuit current	$I_{10(\text{REC})}$	$V_{CC} = 5.0\text{ V}$ REC / PB SW: High	56	(66)	76	mA
REC AGC level	$I_7$	$V_{CC} = 5.0\text{ V}$ REC / PB SW: High	44	(48)	52	mA[p-p]
REC AGC control characteristics	$DI_7$	$V_{CC} = 5.0\text{ V}$ REC / PB SW: High	—	(0.2)	1.0	dB
REC Recording current 2nd harmonic distortion	$D_7$	$V_{CC} = 5.0\text{ V}$ , REC / PB SW: High $V_{IN} = 260\text{ mV[p-p]}$ , 2 MHz	—	(-43)	-35	dB
REC Mode hold voltage	$V_{16H}$	$V_{CC} = 5.0\text{ V}$ , REC / Mute SW: Low $V_{IN} = 260\text{ mV[p-p]}$ , 2 MHz	3.6	—	$V_{CC}$	V
REC Over REC hold voltage	$V_{8L}$	$V_{CC} = 5.0\text{ V}$ REC / PB SW: High	0	—	1.2	V
REC Normal hold voltage	$V_{8M}$	$V_{CC} = 5.0\text{ V}$ REC / PB SW: High	1.8	—	3.2	V
REC S-VHS hold voltage	$V_{8H}$	$V_{CC} = 5.0\text{ V}$ REC / PB SW: High	3.8	—	$V_{CC}$	V
REC Over REC current ratio	$I_{7L} \rightarrow I_7$	$V_{CC} = 5.0\text{ V}$ REC / PB SW: High	1.3	(1.8)	2.3	dB
REC S-VHS current ratio	$I_{7H} \rightarrow I_7$	$V_{CC} = 5.0\text{ V}$ REC / PB SW: High	-2.3	(-1.8)	-1.3	dB
REC Mute hold voltage 1	$V_{14H(\text{REC})}$	$V_{CC} = 5.0\text{ V}$ REC / PB SW: High	3.6	—	$V_{CC}$	V
REC Mute hold voltage 2	$V_{14L(\text{REC})}$	$V_{CC} = 5.0\text{ V}$ REC / PB SW: High	0	—	1.4	V
PB Circuit current	$I_{10(\text{PB})}$	$V_{CC} = 5.0\text{ V}$ REC / PB SW: Low	9	(13)	17	mA
PB CH1 gain	$G_{3-14}$	$V_{CC} = 5.0\text{ V}$ , REC / PB SW: Low HSW: High, $V_{IN} = 0.1\text{ mV[p-p]}$ , 2 MHz	72	(76)	80	dB
PB CH2 gain	$G_{5-14}$	$V_{CC} = 5.0\text{ V}$ , REC / PB SW: Low HSW: Low, $V_{IN} = 0.1\text{ mV[p-p]}$ , 2 MHz	72	(76)	80	dB
PB CH1 1.5 M / 2 M gain ratio	$DG_{3-14}$	$V_{CC} = 5.0\text{ V}$ , REC / PB SW: Low HSW: High, $V_{IN} = 0.1\text{ mV[p-p]}$ , 2 MHz	0	(0.5)	1	dB
PB CH2 1.5 M / 2 M gain ratio	$DG_{5-14}$	$V_{CC} = 5.0\text{ V}$ , REC / PB SW: Low HSW: Low, $V_{IN} = 0.1\text{ mV[p-p]}$ , 2 MHz	0	(0.5)	1	dB
PB CH1 / CH2 gain ratio	$G_{3-14} \rightarrow G_{5-14}$	$V_{CC} = 5.0\text{ V}$ , REC / PB SW: Low $V_{IN} = 0.1\text{ mV[p-p]}$ , 2 MHz	-2	0	2	dB
Noise referred to PB CH1 input	$N_{3-14}$	$V_{CC} = 5.0\text{ V}$ REC / PB SW: Low HSW: High	—	—	1.0	mV[rms]
Noise referred to PB CH2 input	$N_{5-14}$	$V_{CC} = 5.0\text{ V}$ REC / PB SW: Low HSW: Low	—	—	1.0	mV[rms]

Note) The typical value in the parenthesis is not the guaranteed one.

■ Electrical Characteristics at  $T_a = 25^\circ\text{C}$  (continued)

Parameter	Symbol	Conditions	Min	Typ	Max	Unit
PB Mode hold voltage	$V_{16L}$	$V_{CC} = 5.0\text{ V}$ REC / PB SW: Low	0	—	1.4	V
PB CH1 hold voltage	$V_{1H(PB)}$	$V_{CC} = 5.0\text{ V}$ REC / PB SW: Low	3.6	—	$V_{CC}$	V
PB CH2 hold voltage	$V_{1L(PB)}$	$V_{CC} = 5.0\text{ V}$ REC / PB SW: Low	0	—	1.4	V
PB HSW DC unbalanced	$DV_{\text{OFFSET}}$	$V_{CC} = 5.0\text{ V}$ REC / PB SW: Low	—	—	20	mV[p-p]

• Design reference data

Note) The characteristics listed below are theoretical values based on the IC design and are not guaranteed.

Parameter	Symbol	Conditions	Min	Typ	Max	Unit
REC Cross modulation distortion at 0.4 MHz	$CMD_{0.4M}$	$V_{CC} = 5.0\text{ V}$ REC / PB SW: High	—	(-45)	—	dB
REC Cross modulation distortion at 0.9 MHz	$CMD_{0.9M}$	$V_{CC} = 5.0\text{ V}$ REC / PB SW: High	—	(-52)	—	dB
REC Muting ratio	$I_M / I_7$	$V_{CC} = 5.0\text{ V}$ REC / PB SW: High	—	—	-40	dB
PB Crosstalk CH1 to CH2	$CT_1$	$V_{CC} = 5.0\text{ V}$ REC / PB SW: Low	—	-40	—	dB
PB Crosstalk CH2 to CH1	$CT_2$	$V_{CC} = 5.0\text{ V}$ REC / PB SW: Low	—	-40	—	dB
PB CH1, Output 2nd harmonic distortion	$D_{3-14}$	$V_{CC} = 5.0\text{ V}$ , HSW: High REC / PB SW: Low	—	-50	—	dB
PB CH2, Output 2nd harmonic distortion	$D_{5-14}$	$V_{CC} = 5.0\text{ V}$ , HSW : Low REC / PB SW: Low	—	-50	—	dB

Note) The typical value in the parenthesis is not the guaranteed one.

■ Terminal Equivalent Circuits

Pin No.	Equivalent Circuit	Description	Voltage	Remark
1		Audio head SW	Input signal 	At open : High (ch.1 Select)
2		REC regulator 1	D.C	—
3		Head amp. input ch.1	0.7 V	—
4	—	GND (small signal)	—	—
5		Head amp. input ch.2	0.7 V	—

■ Terminal Equivalent Circuits (continued)

Pin No.	Equivalent Circuit	Description	Voltage	Remark
6		REC regulator	2	D.C
7		REC out	A.C	—
9		REC curr. monitor (control)		
8		Curr. emph. SW	Input signal	At open: Middle (Curr. emph. normal mode)
10	—	V <sub>CC</sub>	—	—
11		REC AGC det	D.C	—
12	—	GND	—	—

■ Terminal Equivalent Circuits (continued)

Pin No.	Equivalent Circuit	Description	Voltage	Remark
13		REC input		—
14		PB out & REC / mute SW		At open: Low (REC Mute OFF)
15		Audio REC capacitor	D.C	—
16		REC / PB select SW		At open: Low (PB-Mode)

■ Application Circuit Example

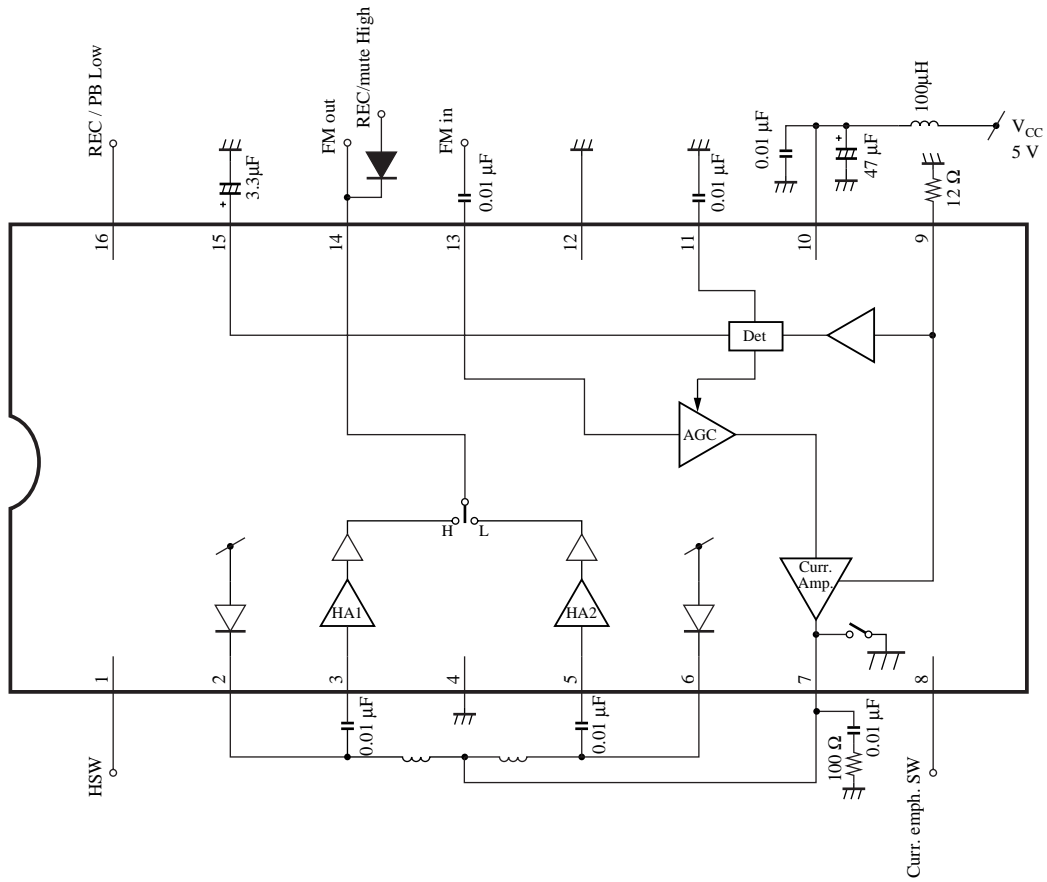



LittleDiode supplies new, hard to find or obsolete electronic components and semiconductors all over the world.

With over two million different components listed you are sure to find the part you need.

Feel free to visit us today at our online store:

[LittleDiode.com](http://LittleDiode.com)

Looking forward to providing you with the best possible service.