

AN3341SC

6-Head VCR Recording/Playback Amplifier IC

■ Overview

The AN3341SC is a recording/playback amplifier IC for 6-head VCR. It is suitable for 19- μ head, EP-mode only, table-type VCR.

■ Features

- Playback $V_{CC}=5.0V$, recording $V_{CC}=12V$
- Built-in RF-AGC circuit
- Built-in automatic tracking I/O circuit
- Built-in envelope comparator circuit

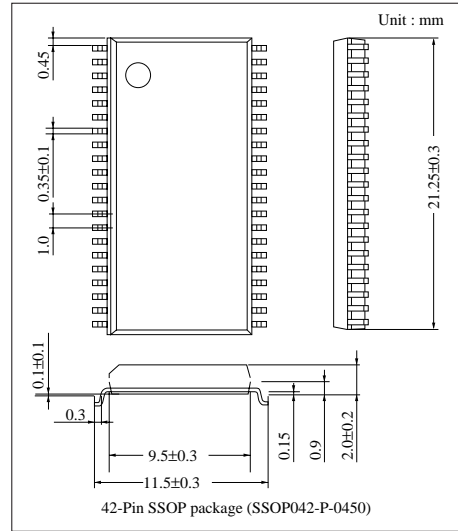

■ Block Diagram

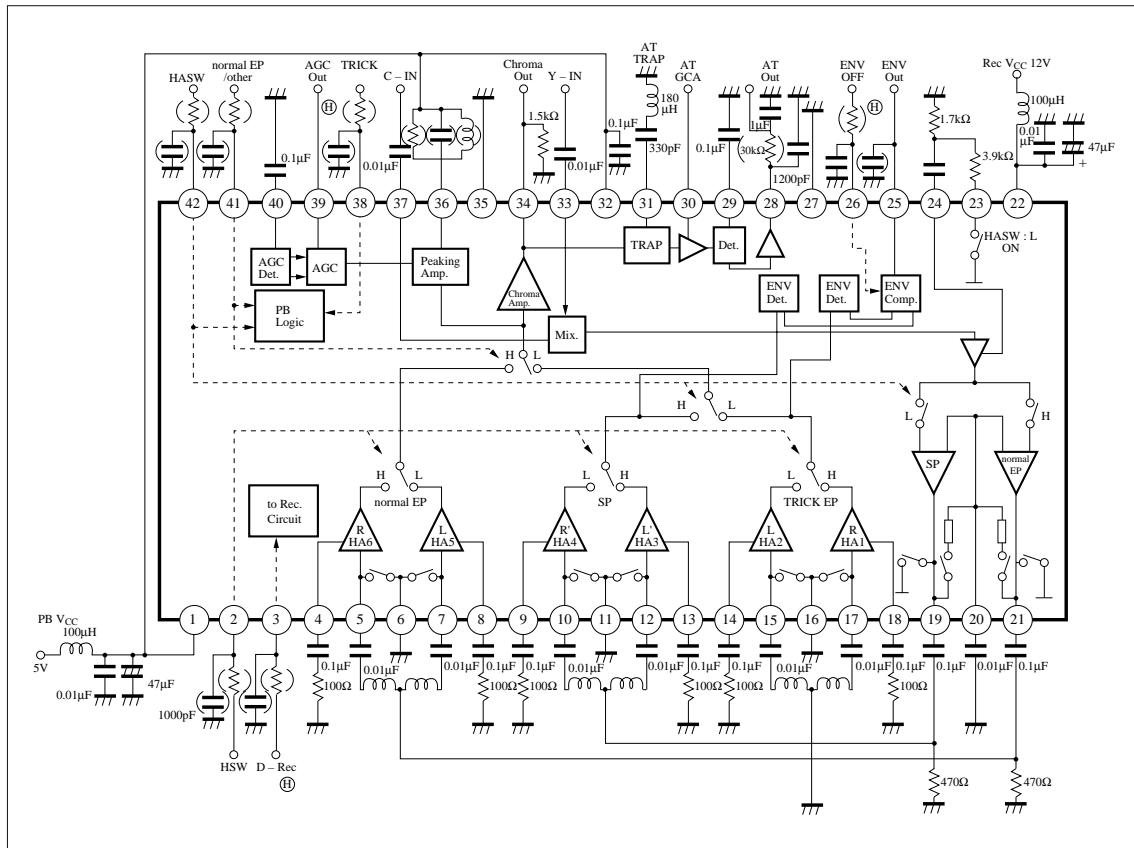

■ Pin Descriptions

Pin No.	Pin name	Pin No.	Pin name
1	Playback V _{CC}	22	Rec. V _{CC}
2	Head switching	23	Rec. current emphasis
3	D-Rec. switching	24	Peaking for recording
4	Ch6 head amp. damping	25	ENV output
5	Ch6 head amp. input	26	ENV OFF switching
6	Small-signal ground	27	Automatic tracking ground
7	Ch5 head amp. input	28	Automatic tracking output
8	Ch5 head amp. damping	29	Automatic tracking detection
9	Ch4 head amp. damping	30	Automatic tracking GCA control
10	Ch4 head amp. input	31	Automatic tracking TRAP
11	Small-signal ground	32	Automatic tracking V _{CC}
12	Ch3 head amp. input	33	Recording Y-input
13	Ch3 head amp. damping	34	Chroma output
14	Ch2 head amp. damping	35	Large signal ground
15	Ch2 head amp. input	36	Peaking amp. (playback)
16	Small-signal ground	37	Recording C-input
17	Ch1 head amp. input	38	Trick switching
18	Ch1 head amp. damping	39	AGC output
19	Rec. current amp. (SP)output	40	AGC. Det
20	Rec. feedback	41	Normal EP/other switching
21	Rec. current amp. (EP)output	42	HASW

■ Absolute Maximum Ratings

Parameter	Symbol	Rating		Unit
		(1)	(2)	
Supply voltage	V _{CC}	PB V _{CC}	6	V
		Rec V _{CC}	13	
Power dissipation ^{Note 2)}	P _D	430		mW
Operating ambient temperature ^{Note 1)}	T _{opr}	- 20 to +70		°C
Storage temperature ^{Note 1)}	T _{stg}	- 55 to +125		°C

Note 1) Ta=25°C except operating ambient temperature and storage temperatures.

Note 2) Allowable power dissipation of the package at Ta=70°C.

■ Recommended Operating Range (Ta = 25°C)

Parameter	Symbol	Range
Operating supply voltage range (1)	PB V _{CC}	4.5V to 5.5V
Operating supply voltage range (2)	Rec V _{CC}	11.5V to 12.5V

■ Electrical Characteristics (Ta = 25±2°C)

Parameter	Symbol	Condition	min	typ	max	Unit
PB circuit current	I ₁	PB V _{CC} = 5V	—	33 *	50	mA
CH1 gain	G ₁₇₋₃₄	PB V _{CC} = 5V	52	56 *	60	dB
CH2 gain	G ₁₅₋₃₄	PB V _{CC} = 5V	52	56 *	60	dB
CH3 gain	G ₁₂₋₃₄	PB V _{CC} = 5V	52	56 *	60	dB
CH4 gain	G ₁₀₋₃₄	PB V _{CC} = 5V	52	56 *	60	dB
CH5 gain	G ₇₋₃₄	PB V _{CC} = 5V	52	56 *	60	dB
CH6 gain	G ₅₋₃₄	PB V _{CC} = 5V	52	56 *	60	dB
HSW threshold level	S ₂	PB V _{CC} = 5V	1.5	2.5 *	3.5	V
HASW threshold level	S ₄₂	PB V _{CC} = 5V	1.5	2.5 *	3.5	V
Normal EP/other threshold level	S ₄₁	PB V _{CC} = 5V	1.5	2.5 *	3.5	V
Trick SW threshold level	S ₃₈	PB V _{CC} = 5V	1.5	2.5 *	3.5	V
AGC output amplitude	V ₁₇₋₃₉	PB V _{CC} = 5V	130	200 *	270	mV _{P-P}
AGC control sensitivity	ΔV ₁₇₋₃₉	PB V _{CC} = 5V	—	—	3.0	dB
HSW DC unbalance (I)	HSW _{2(I)}	PB V _{CC} = 5V	—	—	100	mV _{P-P}
HSW DC unbalance (II)	HSW _{2(II)}	PB V _{CC} = 5V	—	—	100	mV _{P-P}
HSW DC unbalance (III)	HSW _{2(III)}	PB V _{CC} = 5V	—	—	100	mV _{P-P}
HASW DC unbalance (I)	HASW _{42(I)}	PB V _{CC} = 5V	—	—	100	mV _{P-P}
HASW DC unbalance (II)	HASW _{42(II)}	PB V _{CC} = 5V	—	—	100	mV _{P-P}
Input conversion noise CH1	N ₁₇₋₃₄	PB V _{CC} = 5V	—	0.65 *	1.0	μVrms
Input conversion noise CH2	N ₁₅₋₃₄	PB V _{CC} = 5V	—	0.65 *	1.0	μVrms
Input conversion noise CH3	N ₁₂₋₃₄	PB V _{CC} = 5V	—	0.65 *	1.0	μVrms
Input conversion noise CH4	N ₁₀₋₃₄	PB V _{CC} = 5V	—	0.65 *	1.0	μVrms
Input conversion noise CH5	N ₇₋₃₄	PB V _{CC} = 5V	—	0.65 *	1.0	μVrms
Input conversion noise CH6	N ₅₋₃₄	PB V _{CC} = 5V	—	0.65 *	1.0	μVrms
Envelope comparison output amplitude	V ₂₅	PB V _{CC} = 5V	4.0	—	—	V _{P-P}
Auto tracking output at no-input	V _{28min.}	PB V _{CC} = 5V	—	0.3 *	1.0	V
Auto tracking max. output	V _{28max.}	PB V _{CC} = 5V	3.8	4.2 *	—	V
CH2/CH1 gain ratio	$\frac{G_{15-34}}{G_{17-34}}$	PB V _{CC} = 5V	-2	0 *	2	dB
CH3/CH1 gain ratio	$\frac{G_{12-34}}{G_{17-34}}$	PB V _{CC} = 5V	-2	0 *	2	dB
CH4/CH1 gain ratio	$\frac{G_{10-34}}{G_{17-34}}$	PB V _{CC} = 5V	-2	0 *	2	dB
CH5/CH1 gain ratio	$\frac{G_{7-34}}{G_{17-34}}$	PB V _{CC} = 5V	-2	0 *	2	dB
CH6/CH1 gain ratio	$\frac{G_{5-34}}{G_{17-34}}$	PB V _{CC} = 5V	-2	0 *	2	dB
Rec. circuit current	I ₂₂	Rec. V _{CC} = 12V	—	35 *	48	mA
SP Y Rec. current output	I ₁₉	Rec. V _{CC} = 12V	17	24.5 *	32	mA _{P-P}
Normal EP Y Rec. current output ratio	I ₂₁ /I ₁₉	Rec. V _{CC} = 12V	-5.5	-3 *	-0.5	dB
Rec. chroma output ratio	I _{19C} /I ₁₉	Rec. V _{CC} = 12V	-16	-12 *	-8	dB
Head Short ON-resistance	7 _{ON-R}	PB V _{CC} = 5V	—	(5.5)	(7)	Ω
HSW crosstalk	CTH ₁₇₋₃₄	PB V _{CC} = 5V	—	—	(-40)	dB

Note) Values with an asterisk are typical ones and not guaranteed.

The characteristics value in parentheses is not a guaranteed value, but reference one on design.

■ Electrical Characteristics (Ta = 25±2°C)

Parameter	Symbol	Condition	min	typ	max	Unit
HASW crosstalk	CTA ₁₇₋₃₄	PB V _{CC} = 5V	—	—	(- 40)	dB
Normal EP/other crosstalk	CTN ₁₇₋₃₄	PB V _{CC} = 5V	—	—	(- 40)	dB
Input capacitance	C _{in}	PB V _{CC} = 5V	—	(30)	—	pF
Recording current 2nd harmonics distortion	D _{2f-19}	Rec. V _{CC} = 12V	—	(- 50)	—	dB
Cross-modulation relative level	D _{M-19}	Rec. V _{CC} = 12V	—	(- 50)	—	dB
ENV-OFF SW threshold level	S ₂₆	PB V _{CC} = 5V	(1.5)	(2.5)	(3.5)	V
PB f characteristics ratio	V ₃₄ /V ₃₄	PB V _{CC} = 5V	(- 4)	(0)	—	dB
SP 8MHz f characteristics ratio	I _{19H} /I ₁₉	Rec. V _{CC} = 12V	(- 4)	(0)	—	dB
Normal EP 8MHz f characteristics ratio	I _{21H} /I ₂₁	Rec. V _{CC} = 12V	(- 4)	(0)	—	dB
Auto tracking 7MHz max. output	V _{28-7M}	PB V _{CC} = 5V	(3.8)	(4.2)	—	V

Note) The characteristics value in parentheses is not a guaranteed value, but reference one on design.



LittleDiode supplies new, hard to find or obsolete electronic components and semiconductors all over the world.

With over two million different components listed you are sure to find the part you need.

Feel free to visit us today at our online store:

LittleDiode.com

Looking forward to providing you with the best possible service.