

AN3988NFHP

Stereo Audio-Signal Processor IC for 8-mm Video Camera

■ Overview

The AN3988NFHP is a stereo audio signal processor IC for 8-mm video camera. It provides full audio signal processing functions for 8-mm video camera, making them less power consumption, and more compact by space saving of set.

■ Features

- Including full playback BPFs
- Low operating voltage (3 to 5V supply voltage)
- Low power consumption : 130mW for recording at $V_{CC}=3.3V$

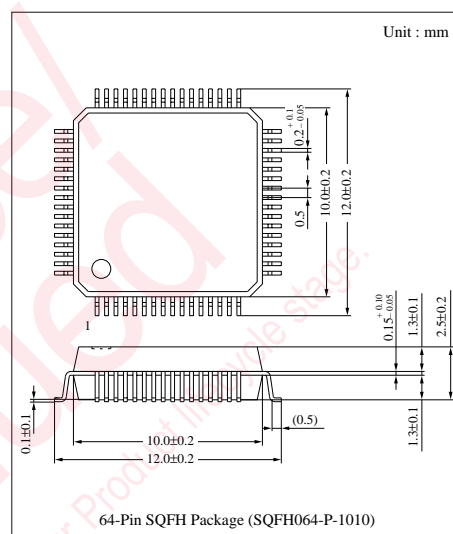

■ Absolute Maximum Ratings

| Parameter | Symbol | Rating | Unit |
|--|-----------|-------------|------|
| Supply voltage | V_{CC1} | 5.5V | V |
| | V_{CC2} | 5.5V | V |
| Power dissipation ^{Note 2)} | P_D | 331 | mW |
| Operating ambient temperature ^{Note 1)} | T_{opr} | -20 to +70 | °C |
| Storage temperature ^{Note 1)} | T_{stg} | -55 to +125 | °C |

Note 1) $T_a=25^\circ\text{C}$ except operating ambient temperature and storage temperature.

Note 2) Allowable power dissipation of the package at $T_a=70^\circ\text{C}$.

■ Recommended Operating Range ($T_a=25^\circ\text{C}$)

| Parameter | Symbol | Range |
|--------------------------------|-----------|--------------|
| Operating supply voltage range | V_{CC1} | 3.0V to 5.0V |
| | V_{CC2} | 4.5V to 5.0V |

■ Block Diagram

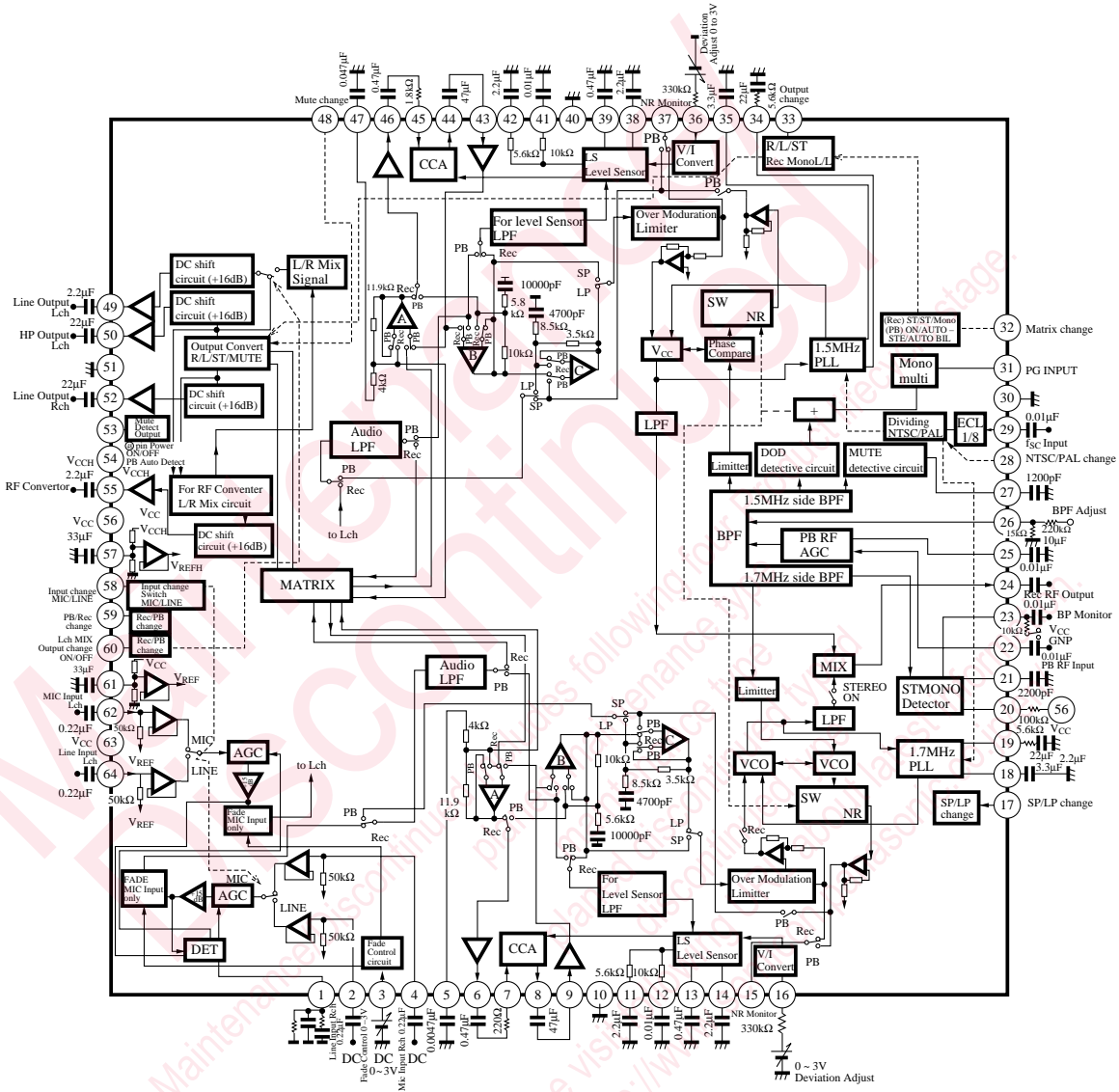

■ Electrical Characteristics ($V_{CC1} = 4.75V$, $V_{CC2} = 4.75V$, $T_a = 25 \pm 2^\circ C$)

| Parameter | Symbol | Condition | min | typ | max | Unit |
|---|----------------------------|--|-------|------|-------|------|
| Circuit current on recording mode 1 | I_{63R} | $V_{CC1} = 4.75V$ Rec in no signal | 29 | 37 | 45 | mA |
| Circuit current on recording mode 2 | I_{54R} | $V_{CC1} = 4.75V$ Rec in no signal | 5 | 7 | 9 | mA |
| Circuit current on PB mode 1 | I_{63P} | $V_{CC1} = 4.75V$ PB in no signal | 27 | 34 | 41 | mA |
| Circuit current on PB mode 2 | I_{54P} | $V_{CC1} = 4.75V$ PB in no signal | 37 | 47 | 57 | mA |
| Microphone AGC reference output level | V_{OALL} V_{OALR} | $V_{in} = -38dBs$ $f = 400Hz$ | -8 | -7 | -6 | dBs |
| Microphone AGC reference output level R/L | B_{AC1} | V_{OALR}/V_{OALL} difference | -0.55 | 0 | +0.55 | dBs |
| Microphone AGC reference output level output distortion ratio | T_{HALL1} T_{HALR1} | $V_{in} = -38dBs$, 1kHz up to THD 10th | — | 0.02 | 0.1 | % |
| Microphone AGC ON output level 1 (RE + 4dB) | V_{OALL1} V_{OALR1} | $V_{in} = -34dBs$ $f = 400Hz$ | -5.0 | -3.0 | -1.0 | dBs |
| Microphone AGC ON output level 2 (REF + 20dB) | V_{OALL2} V_{OALR2} | $V_{in} = -18dBs$ $f = 400Hz$ | -5.0 | -2.0 | +1.0 | dBs |
| Microphone AGC ON output level 3 (REF + 36dB) | V_{OALL3} V_{OALR3} | $V_{in} = -2dBs$ $f = 400Hz$ | -3.0 | 0.0 | +3.0 | dBs |
| Microphone AGC ON output level difference 1 (+20dB/+ 4dB) | R_{VOL12} R_{VOR12} | V_{OALL2}/V_{OALL1} V_{OALR2}/V_{OALR1} | -0.5 | 1.0 | — | dB |
| Microphone AGC ON output level difference 1 (+36dB/+ 20dB) | R_{VOL23} R_{VOR23} | V_{OALL3}/V_{OALL2} V_{OALR3}/V_{OALR2} | -0.5 | 2.0 | — | dB |
| Microphone AGC ON output distortion ratio (REF + 36dB) | T_{HALL3} T_{HALR3} | $V_{in} = -2dBs$, 1kHz up to THD 10th | — | 0.35 | 1.0 | % |
| Fade maximum attenuation output | V_{FALL} V_{FALR} | $V_{in} = -38dBs$, 1kHz A curve filter | — | -74 | -69 | dBs |
| E-E system monitor frequency characteristics 1 | V_{OLFL1} V_{OLFR1} | $V_{in} = -38dBs$ 20kHz/400Hz ratio | -1 | 0 | +1 | dB |
| E-E system monitor frequency characteristics 2 | V_{OLFL2} V_{OLFR2} | $V_{in} = -38dBs$ 50kHz/400Hz ratio | — | — | -5 | dB |
| Microphone AGC output noise voltage | V_{NALL} V_{NALR} | No input, A curve filter | — | -73 | -71 | dBs |
| Line reference output level | V_{OLL1} V_{OLLR} | $V_{in} = -38dBs$ $f = 400Hz$ | -8 | -7 | -6 | dBs |
| Line reference output R/L difference | B_{LL1} | $V_{in} = -38dBs$ V_{OLLR}/V_{OLL1} ratio | -0.55 | 0 | +0.55 | dB |
| Line reference output distortion ratio (THD) | T_{HLLL1} T_{HLLR1} | $V_{in} = -38dBs$, 1kHz up to THD 10th | — | 0.02 | 0.1 | % |
| Line output noise voltage | V_{NLLL} V_{NLLR} | No input, A curve filter | — | -73 | -71 | dBs |
| Crosstalk between microphone and line, or between inputs | V_{CTINL} V_{CTINR} | $V_{in} = -28dBs$, 1kHz A curve filter | — | -68 | -66 | dBs |
| E-E system channel crosstalk | V_{CTLRL} V_{CTLR} | $V_{in} = -28dBs$, 1kHz A curve filter | — | -69 | -67 | dBs |
| Line max. output level | V_{OLML} V_{OLMR} | $f = 1kHz$, 47k Ω when load THD=1% | 0.5 | 2.0 | — | dBs |
| Head-phone reference output level | V_{HCSL} V_{HCSR} | $V_{in} = -38dBs$, 400Hz 120 + 8 Ω load, 8 Ω end | -33 | -31 | -29 | dBs |
| Head-phone reference output level R/L difference | B_{HCS} | $V_{in} = -38dBs$, 400Hz 120 + 8 Ω load, 8 Ω end | -1 | 0 | +1 | dB |
| Head-phone reference output level output distortion ratio | T_{HHCSL} T_{HHCSR} | $V_{in} = -38dBs$, 1kHz 120 + 8 Ω load, 8 Ω end | — | 0.03 | 0.5 | % |
| Head-phone output noise voltage | V_{NHCOL} V_{NHCOR} | No input, A curve filter | — | -97 | -93 | dBs |

Note) Unless otherwise specified, a 30-kHz LPF is used, and level is measured at 400Hz except that distortion or cross-talk is measured at 1kHz.

■ Electrical Characteristics (cont.) ($V_{CC1} = 4.75V$, $V_{CC2} = 4.75V$, $T_a = 25 \pm 2^\circ C$)

| Parameter | Symbol | Condition | min | typ | max | Unit |
|---|----------------------------|---|-------|-------|-------|------------|
| Head-phone maximum output voltage | V_{MH8L} V_{MH8R} | $f=1kHz$, at load of $THD=1\%$ at $120 + 8\Omega$ load pin | -1.0 | +1.0 | — | dBs |
| Line mute attenuation output | V_{MLML} V_{MLMR} | $V_{in} = -28dBs$, 1kHz A curve filter | — | -86 | -80 | dBs |
| Deviation adjustment range | DEV36 DEV16 | Adjust Pin16 and Pin36 through resistor, so as Rec FM deviation to be $60 \pm 0.2kHz$ for 1.5 MHz side, and $30 \pm 0.1kHz$ for 1.7MHz side, (thereafter, the adjusted voltage maintained) $R=330k\Omega$. | 0.1 | — | 2.9 | V |
| NR encode reference output level distortion factor (THD) | T_{HORLL} T_{HORLR} | $V_{in} = -38dBs$, 1kHz Line In, *TEST mode | — | 0.2 | 0.5 | % |
| NR encode linearity | V_{ORLL} V_{ORLR} | $V_{in} = -38dBs /$ $-78dBs$, 400Hz Line In, TEST mode | -22.5 | -21.5 | -20.5 | dB |
| NR encode frequency characteristics SP mode | V_{FSRL} V_{FSRLR} | $V_{in} = -48dBs$, TEST mode Ratio of $f=10kHz/400Hz$ | 3.6 | 4.8 | 6.0 | dB |
| NR encode frequency characteristics LP mode | V_{FPRL} V_{FPRLR} | $V_{in} = -48dBs$, TEST mode Ratio of $f=10kHz$, LP/SP | 2.2 | 2.7 | 3.2 | dB |
| Encode stereo separation in-phase | V_{BSRLR} | $V_{in} = -38dBs$, 400Hz Ratio of DEV 16/DEV 36 STEREO | — | -25 | -17.5 | dB |
| Encode stereo separation anti-phase | V_{BSRL} | $V_{in} = -38dBs$, 400Hz Ratio of DEV 16/DEV 36 STEREO | — | -25 | -17.5 | dBs |
| Encode output noise voltage | V_{NRRL} V_{NRRLR} | No input, A curve filter | — | -56 | -53 | dBs |
| Encode channel crosstalk | S_{ERL} S_{ERR} | $V_{in} = -28dBs$, 1kHz A curve filter | — | -56 | -53 | dBs |
| VCO (NTSC mode) oscillation frequency 1.5MHz | F_{ONTL} | $f_{sc}=3.579545$ (MHz) $V_{fsc}=200mV_{p-p}$ | 1.499 | 1.500 | 1.501 | MHz |
| VCO (NTSC mode) oscillation frequency 1.7MHz | F_{ONTR} | $f_{sc}=3.579545$ (MHz) $V_{fsc}=200mV_{p-p}$ | 1.699 | 1.700 | 1.701 | MHz |
| VCO (PAL mode) oscillation frequency 1.5MHz | F_{OPAL} | $f_{sc}=4.433619$ (MHz) $V_{fsc}=200mV_{p-p}$ | 1.499 | 1.500 | 1.501 | MHz |
| VCO (PAL mode) oscillation frequency 1.7MHz | F_{OPAR} | $f_{sc}=4.433619$ (MHz) $V_{fsc}=200mV_{p-p}$ | 1.699 | 1.700 | 1.701 | MHz |
| VCO output level Lch (1.5MHz) | V_{VCL} | Carrier level measurement of 1.5MHz | 198 | 220 | 245 | mV_{p-p} |
| VCO output level Rch (1.7MHz) | V_{VCR} | Carrier level measurement of 1.7MHz | 157 | 175 | 194 | mV_{p-p} |
| FM (VCO) output L/R mix ratio | V_{COMIX} | Ratio of stereo, NTSC mode 1.5MHz/1.7MHz | 1.5 | 2.0 | 2.5 | dB |
| FM (VCO) output 2nd harmonics distortion 1.5MHz | V_{VCL2} | Load above $10k\Omega$, regard fundamental wave as 0dB | — | -42 | -35 | dB |
| FM (VCO) output 2nd harmonics distortion 1.7MHz | V_{VCR2} | Load above $10k\Omega$, regard fundamental wave as 0dB | — | -42 | -35 | dB |
| FM (VCO) output 3rd harmonics distortion 1.5MHz | V_{VCL3} | Load above $10k\Omega$, regard fundamental wave as 0dB | — | -50 | -40 | dB |
| FM (VCO) output 3rd harmonics distortion 1.7MHz | V_{VCR3} | Load above $10k\Omega$, regard fundamental wave as 0dB | — | -50 | -40 | dB |

* Pin20 is at 0V in the MONO mode.

Note) Unless otherwise specified, a 30-kHz LPF is used, and level is measured at 400Hz except that distortion or cross-talk is measured at 1kHz.

Electrical Characteristics (cont.) ($V_{CC1} = 4.75V$, $V_{CC2} = 4.75V$, $T_a = 25 \pm 2^\circ C$)

| Parameter | Symbol | Condition | min | typ | max | Unit |
|--|----------------------------|---|------|------|-------|------------|
| Reference FM modulation distortion factor Lch, Rch | T_{HDFML} T_{HDFMR} | $V_{in} = -38dBs$, 400Hz Line In, mono mode, SP | — | 0.2 | 0.4 | % |
| BRF adjustment voltage $f=1.625MHz$ | B_{PFADJ} | At $f=1.625MHz$, $V_{in}=15mV_{P-P}$, change Pin23 through $10k\Omega$ to V_{CC} or to GND, and adjust Pin26 to make level equal. | 0.1 | — | 4.65 | V |
| BPF MAIN 1.5MHz monitor level | B_{FM150} | $V_{in}=15.0mV_{P-P}$ $f=1.50MHz$ SP mode | 90 | 130 | 170 | mV_{P-P} |
| BPF MAIN frequency characteristics 0.80MHz/1.50MHz | B_{FM080} | $V_{in}=15.0mV_{P-P}$ $f=0.80MHz$ | — | -50 | -43 | dB |
| BPF MAIN 1.40MHz/1.50MHz | B_{FM140} | $V_{in}=15.0mV_{P-P}$ $f=1.40MHz$ | -7.0 | -3.5 | 0 | dB |
| BPF MAIN 1.60MHz/1.50MHz | B_{FM160} | $V_{in}=15.0mV_{P-P}$ $f=1.60MHz$ | -7.0 | -3.5 | 0 | dB |
| BPF MAIN 1.65MHz/1.50MHz | B_{FM165} | $V_{in}=15.0mV_{P-P}$ $f=1.65MHz$ | — | -15 | -7 | dB |
| BPF MAIN 2.50MHz/1.50MHz | B_{FM250} | $V_{in}=15.0mV_{P-P}$ $f=2.50MHz$ | — | -50 | -43 | dB |
| BPF SUB 1.7MHz monitor level | B_{FS170} | $V_{in}=12mV_{P-P}$ $f=1.70MHz$ SP mode | 70 | 115 | 160 | mV_{P-P} |
| BPF frequency characteristics 1.50MHz/1.70MHz | B_{FS150} | $V_{in}=12mV_{P-P}$ $f=1.50MHz$ | — | -35 | -22.5 | dB |
| BPF frequency characteristics 1.60MHz/1.70MHz | B_{FS160} | $V_{in}=12mV_{P-P}$ $f=1.60MHz$ | — | -15 | -9.0 | dB |
| BPF frequency characteristics 1.65MHz/1.70MHz | B_{FS165} | $V_{in}=12mV_{P-P}$ $f=1.65MHz$ | -7.0 | -3.5 | 0 | dB |
| BPF frequency characteristics 1.75MHz/1.70MHz | B_{FS175} | $V_{in}=12mV_{P-P}$ $f=1.75MHz$ | -7.0 | -3.5 | 0 | dB |
| BPF frequency characteristics 1.90MHz/1.70MHz | B_{FS190} | $V_{in}=12mV_{P-P}$ $f=1.90MHz$ | — | -50 | -25 | dB |
| LP/SP BPF input output gain difference | G_{BLPSP} | $V_{in}=15.0mV_{P-P}$ $f=1.5MHz$ LP/SP | 1.0 | 2.0 | 3.0 | dB |
| fsc input level range | V_{fsc} | Guaranteed fsc level range of F_{ONTL} , F_{ONTR} , F_{OPAL} and F_{OPAR} | 100 | 200 | 1000 | mV_{P-P} |
| PB FM demodulation output voltage BIL mode Lch (equal to self-PB level) | V_{BILPL} | $V_{cL}=15mV_{P-P}$, 1.5MHz DEV= 60kHz, fm=1kHz | -9.0 | -7.0 | -5.0 | dBs |
| PB FM demodulation output voltage BIL mode Rch (equal to self-PB level) | V_{BILPR} | $V_{cR}=12mV_{P-P}$, 1.7MHz DEV= 30kHz, fm=1kHz | -9.0 | -7.0 | -5.0 | dBs |
| PB FM demodulation output distortion factor BIL mode Lch | T_{HBLPL} | $V_{cL}=15mV_{P-P}$, 1.5MHz DEV= 60kHz, fm=1kHz | — | 0.2 | 0.5 | % |
| PB FM demodulation output distortion factor BIL mode Rch | T_{HBLPR} | $V_{cR}=12mV_{P-P}$, 1.7MHz DEV= 30kHz, fm=1kHz | — | 0.2 | 0.5 | % |
| PB FM demodulation output voltage 1 STE mode Lch | V_{SLP1L} | $V_{cL}=15mV_{P-P}$, 1.5MHz DEV= 60kHz, fm=1kHz | -9.0 | -7.0 | -5.0 | dBs |
| PB FM demodulation output voltage 1 STE mode Rch | V_{SLP1R} | $V_{cR}=12mV_{P-P}$, 1.7MHz DEV= 0kHz | -9.0 | -7.0 | -5.0 | dBs |
| PB FM demodulation output voltage 2 STE mode Lch | V_{SLP2L} | $V_{cL}=15mV_{P-P}$, 1.5MHz DEV= 0kHz | -9.0 | -7.0 | -5.0 | dBs |
| PB FM demodulation output voltage 2 STE mode Rch | V_{SLP2R} | $V_{cR}=12mV_{P-P}$, 1.7MHz DEV= 30kHz, fm=1kHz | -9.0 | -7.0 | -5.0 | dBs |
| PB FM demodulation output noise BIL mode L,R | V_{NLPL} V_{NLPR} | $V_{cL}=15mV_{P-P}$, 1.5MHz $V_{cR}=12mV_{P-P}$, 1.7MHz | — | -81 | -76 | dBs |
| Self Rec. PB R/L level difference | B_{BRP} | V_{BILPR}/V_{BILPL} | -1.5 | 0 | +1.5 | dB |

Note) Unless otherwise specified, a 30-kHz LPF is used, and level is measured at 400Hz except that distortion or cross-talk is measured at 1kHz.

■ Electrical Characteristics (cont.) ($V_{CC1} = 4.75V$, $V_{CC2} = 4.75V$, $T_a = 25 \pm 2^\circ C$)

| Parameter | Symbol | Condition | min | typ | max | Unit |
|---|-------------|---|-------|-----|-----------|---------|
| Stereo mode self recording & playback channel separation positive phase | S_{SRPR} | $V_{in} = -38dBs$, 400Hz Lch line input, Lch ratio | — | -30 | -23.5 | dB |
| Stereo mode self recording & playback channel separation negative phase | S_{SRPL} | $V_{in} = -38dBs$, 400Hz Rch line input, Rch ratio | — | -30 | -23.5 | dB |
| Dropout detection ON level | DODON | BPF monitor voltage of 1.5MHz Set $130mV_{P-P}$ at 0dB, $f=1.5MHz$, SP mode | -18 | -14 | -11 | dB |
| Dropout detection OFF level hysteresis width | DODOFF | BPF monitor voltage of 1.5MHz $130mV_{P-P} = 0dB$ $f=1.5MHz$, SP mode Ratio to DODON | 0.5 | 4.5 | 6.5 | dB |
| Start delay time at Mute ON | T_{MTON} | Delay time of after carrierlack to MUTE beginning | 260 | 340 | 430 | μs |
| Mute holding time at Mute release | T_{MTOFF} | MUTE hold time when MUTE released | 113 | 133 | 153 | ms |
| Monaural automatic detection ON level | AMOON | BPF monitor voltage of 1.7MHz $130mV_{P-P} = 0dB$ $f=1.7MHz$, SP mode | -11.5 | -9 | -7.5 | dB |
| Monaural automatic detection OFF level hysteresis width | AMOOFF | BPF monitor voltage of 1.7MHz $130mV_{P-P} = 0dB$ $f=1.7MHz$, SP mode, Ratio to AMOON | 1.0 | 3.0 | 5.0 | dB |
| Monaural holding time at monaural release | T_{MNOFF} | Monaural holding time at monaural release | 113 | 133 | 153 | ms |
| Input change-over holding voltage microphone input | V_{58MIC} | | 2.0 | — | V_{CC1} | V |
| Input change-over holding voltage line input | V_{58LIN} | | 0 | — | 1.0 | V |
| SP/LP change-over holding voltage SP mode | V_{17SP} | | 2.0 | — | V_{CC1} | V |
| SP/LP change-over holding voltage LP mode | V_{17LP} | | 0 | — | 1.0 | V |
| NTSC/PAL change-over holding voltage NTSC | V_{28NT} | | 2.0 | — | V_{CC1} | V |
| NTSC/PAL change-over holding voltage PAL | V_{28PA} | | 0 | — | 1.0 | V |
| Line mute change-over holding voltage ON | V_{48MO} | | 2.0 | — | V_{CC1} | V |
| Line mute change-over holding voltage OFF | V_{48MF} | | 0 | — | 1.0 | V |
| PB/Rec change-over holding voltage PB | V_{59PB} | | 2.0 | — | V_{CC1} | V |
| PB/Rec change-over holding voltage Rec | V_{59RE} | | 0 | — | 1.0 | V |
| Output change-over holding voltage SUB/SUB (R/R) | V_{33RR} | | 2.3 | — | V_{CC1} | V |
| Output change-over holding voltage MAIN/SUB (L/L) | V_{33LL} | | 1.3 | — | 1.7 | V |
| Output change-over holding voltage MAIN/SUB (STEREO) | V_{33ST} | | 0 | — | 0.7 | V |
| Recording system matrix holding voltage (stereo) | V_{32ST} | | 2.3 | — | V_{CC1} | V |
| Recording system matrix holding voltage (monaural) | V_{32MO} | | 0 | — | 1.3 | V |
| PB system matrix holding voltage forced ON | V_{32ON} | | 2.3 | — | V_{CC1} | V |
| PB system matrix holding voltage forced STEREO-AUTO | V_{32AT} | | 1.3 | — | 1.7 | V |
| PB system matrix holding voltage forced BIL-AUTO | V_{32OF} | | 0 | — | 0.7 | V |
| Line Lch output MIX switch ON | V_{60MXO} | | 2.3 | — | V_{CC1} | V |

Note) Unless otherwise specified, a 30-kHz LPF is used, and level is measured at 400Hz except that distortion or cross-talk is measured at 1kHz.

■ Electrical Characteristics (cont.) ($V_{CC1} = 4.75V$, $V_{CC2} = 4.75V$, $T_a = 25 \pm 2^\circ C$)

| Parameter | Symbol | Condition | min | typ | max | Unit |
|---|-----------------------------|--|------|-----|------|-------------------|
| Line Lch output MIX switch OFF | V_{60MXF} | | 0 | — | 0.7 | V |
| Output change-over terminal voltage | V_{33} | | 1.31 | — | 1.69 | V |
| PB system matrix terminal voltage | V_{32} | | 1.31 | — | 1.69 | V |
| Fade control non-attenuating holding voltage | V_{FANOL} V_{FANOR} | Measure control voltage range of ineffective fading. | 0 | — | 0.6 | V |
| E-E system MUTE change-over output stage difference | V_{DCROL} V_{DCROR} | Line output DC level difference in recording at MUTE ON/OFF | -200 | — | +200 | mV _{P-P} |
| LP emphasis frequency characteristics 2kHz (LP/SP) | V_{DCPOL} V_{DCPOR} | Line output DC level difference in playback at MUTE ON/OFF | -100 | — | +100 | mV _{P-P} |
| PB system output stage difference at MUTE change-over | V_{FPRL2} V_{FPRLR2} | TEST mode $f=2kHz$, ratio to LP/SP | 1.0 | 1.4 | 1.8 | dB |
| Audio limiter level Lch, when recording | V_{ALIML} | Measure maximum deviation with $V_{in} = -2dBs$, $f=10kHz$ | 84 | 100 | 116 | kHz |
| Audio limiter level Rch, when recording | V_{ALIMR} | Measure maximum deviation with $V_{in} = -2dBs$, $f=10kHz$ | 42 | 50 | 58 | kHz |
| MUTE automatic detection ON level | AMUTON | BPF monitor voltage at 1.5MHz Set 130mV _{P-P} at 0dB, $f_c=1.5MHz$ SP mode | -12 | -9 | -7 | dB |
| MUTE automatic detection OFF hysteresis width | AMUTOFF | BPF monitor voltage at 1.5MHz Set 130mV _{P-P} at 0dB, $f_c=1.5MHz$ Ratio of SP mode to AMUTON | 1 | 3 | 5 | dB |

Note) Unless otherwise specified, a 30-kHz LPF is used, and level is measured at 400Hz except that distortion or cross-talk is measured at 1kHz.

■ Pin Descriptions

| Pin No. | Pin name | Pin No. | Pin name |
|---------|--|---------|---|
| 1 | Input AGC detection | 33 | Output switching control |
| 2 | Line input (R channel) | 34 | PLL loop filter (L channel) |
| 3 | Fade control | 35 | PLL smoothing capacitor (L channel) |
| 4 | Mic. input (R channel) | 36 | Deviation control (L channel) |
| 5 | To an FM emphasis capacitor (R channel) | 37 | NR monitor (L channel) |
| 6 | NR input amp. (R channel) | 38 | LS recovery capacitor (L channel) |
| 7 | CCA input 1 (R channel) | 39 | LS hold capacitor (L channel) |
| 8 | CCA output 1 (R channel) | 40 | GND |
| 9 | CCA input 2 (R channel) | 41 | LS weighting capacitor (2L) |
| 10 | GND | 42 | LS weighting capacitor (1L) |
| 11 | LS weighting capacitor (1R) | 43 | CCA input 2 (L channel) |
| 12 | LS weighting capacitor (2R) | 44 | CCA output 1 (L channel) |
| 13 | LS hold capacitor (R channel) | 45 | CCA input 1 (L channel) |
| 14 | LS recovery capacitor (R channel) | 46 | NR input amp. (L channel) |
| 15 | NR monitor (R channel) | 47 | To an FM emphasis capacitor (L channel) |
| 16 | Deviation control (R channel) | 48 | Mute control |
| 17 | SP/LP switching | 49 | Line output (L channel) |
| 18 | PLL smoothing capacitor (R channel) | 50 | Headphone output (L channel) |
| 19 | PLL loop filter | 51 | GND |
| 20 | Mono mode discrimination | 52 | Line/headphone output (R channel) |
| 21 | STEREO/MONO discrimination and detection | 53 | Mute discrimination output |
| 22 | Playback RF input | 54 | V _{CCH} |
| 23 | BPF monitor | 55 | RF converter output |
| 24 | Recording FM output | 56 | V _{CC} |
| 25 | BPF AGC detection | 57 | 1/2 V _{CCH} (V _{REFH}) |
| 26 | BPF control | 58 | Input switching |
| 27 | Mute detection | 59 | PB/rec switching |
| 28 | PAL/NTSC switching | 60 | Line L channel MIX output switching |
| 29 | fsc input | 61 | 1/2 V _{CC} (V _{REF}) |
| 30 | GND | 62 | Mic input (L channel) |
| 31 | PG pulse input | 63 | V _{CC} |
| 32 | Matrix switching | 64 | Line input (L channel) |

■ Reference

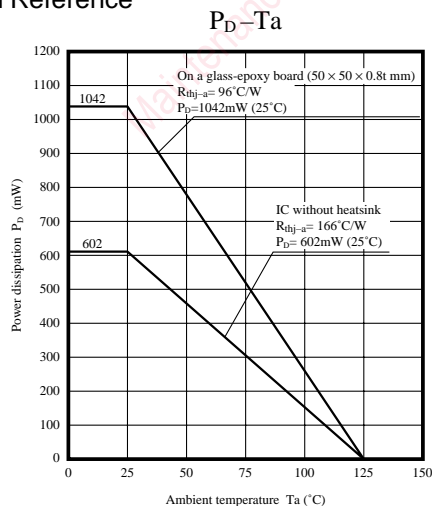

(Usage notes)

1. To reduce temperature dependency of BPF frequency characteristics, it is recommended that the resistor and the variable resistor at Pin26 should be metal film type and thermistor variable resistor.
2. To reduce distortion at low frequencies, capacitances between Pins8 and 9, and between Pins43 and 44 should be increased, (for example, to 220 μF).
3. The surge breakdown level for Pins38, 39, and 53 is 160 to 200 V (with a capacitance of 200pF). Ensure that the voltage at these pins does not exceed the level.

■ Pin Descriptions

| Pin No. | Waveform · Voltage | Equivalent circuit | Pin No. | Waveform · Voltage | Equivalent circuit |
|---------|--|--------------------|--------------------|---|--------------------|
| 20 | Mono/stereo discrimination Pull-up by an external 100kΩ resistor 0V for stereo and 4.75V for mono mode | | 21 27 | Mono mode discrimination and detection | |
| 22 | Playback RF input 2.375V | | 23 | BPF monitor Connected to VCCH/GND through an external 10kΩ resistor. | |
| 24 | Rec FM output 2.8V | | 25 | RF AGC | |
| 26 | BPF fo adjustment 1.5V | | 29 | fsc input 200mV _{p-p} | |
| 1 | Mic line input AGC detection | | 2 4 62 64 | Line input Mic input -38dBs 2.375V | |

Note) The value in the above characteristics is not a guaranteed value, but reference one on design.

■ Pin Descriptions(cont.)

| Pin No. | Waveform · Voltage | Equivalent circuit | Pin No. | Waveform · Voltage | Equivalent circuit |
|----------------------|----------------------------------|--------------------|----------------------|-------------------------------------|--------------------|
| 3 | Fade control input DC 0 to 3V | | 5 47 | FM emphasis 2.375V | |
| 7 45 | - 23dBs 2.375V | | 6 46 | - 23dBs 2.375V | |
| 8 44 | 2.375V | | 9 43 | 2.375V | |
| 10 30 40 51 | GND | | 11 12 41 42 | LS weighting 2.375V | |
| 13 14 38 39 | LS weighting 2.375V | | 15 37 | NR monitor - 23dBs 2.375V | |

Note) The value in the above characteristics is not a guaranteed value, but reference one on design.

■ Pin Descriptions (cont.)

| Pin No. | Waveform · Voltage | Equivalent circuit | Pin No. | Waveform · Voltage | Equivalent circuit |
|----------|------------------------------|--------------------|----------|--|--------------------|
| 16 36 | DEV control input 0 to 3V | | 17 48 | SP/LP switching MUTE switching 3.0V | |
| 18 35 | 2.375V | | 19 34 | 2.375V | |
| 31 | PG input 30Hz 2.375V | | | | |
| 32 | Matrix switching 1.5V | | | | |
| 33 | Output switching 1.5V | | | | |

Note) The value in the above characteristics is not a guaranteed value, but reference one on design.

■ Pin Descriptions(cont.)

| Pin No. | Waveform · Voltage | Equivalent circuit | Pin No. | Waveform · Voltage | Equivalent circuit |
|----------------------|--|--------------------|---------|--|--------------------|
| 28 58 59 60 | PAL/NTSC switching Rec/PB input switching L channel Mix switch 0V | | 49 | LINE L channel output -7dBs 2.375V | |
| 50 52 | HP output L channel LINE/HP R channel output -7dBs 2.375V | | 53 | MUTE discrimination output | |
| 54 | V _{CCH} 4.75V | / | 55 | RF converter output -7dBs 2.375V | |
| 56 63 | V _{CC} 4.75V | | 57 | V _{REFH} 2.375V | |
| 61 | V _{REF} 2.375V | | | | |

Note) The value in the above characteristics is not a guaranteed value, but reference one on design.

Request for your special attention and precautions in using the technical information and semiconductors described in this book

- (1) If any of the products or technical information described in this book is to be exported or provided to non-residents, the laws and regulations of the exporting country, especially, those with regard to security export control, must be observed.
- (2) The technical information described in this book is intended only to show the main characteristics and application circuit examples of the products, and no license is granted under any intellectual property right or other right owned by our company or any other company. Therefore, no responsibility is assumed by our company as to the infringement upon any such right owned by any other company which may arise as a result of the use of technical information described in this book.
- (3) The products described in this book are intended to be used for standard applications or general electronic equipment (such as office equipment, communications equipment, measuring instruments and household appliances).
Consult our sales staff in advance for information on the following applications:
 - Special applications (such as for airplanes, aerospace, automobiles, traffic control equipment, combustion equipment, life support systems and safety devices) in which exceptional quality and reliability are required, or if the failure or malfunction of the products may directly jeopardize life or harm the human body.
 - Any applications other than the standard applications intended.
- (4) The products and product specifications described in this book are subject to change without notice for modification and/or improvement. At the final stage of your design, purchasing, or use of the products, therefore, ask for the most up-to-date Product Standards in advance to make sure that the latest specifications satisfy your requirements.
- (5) When designing your equipment, comply with the range of absolute maximum rating and the guaranteed operating conditions (operating power supply voltage and operating environment etc.). Especially, please be careful not to exceed the range of absolute maximum rating on the transient state, such as power-on, power-off and mode-switching. Otherwise, we will not be liable for any defect which may arise later in your equipment.
 - Even when the products are used within the guaranteed values, take into the consideration of incidence of break down and failure mode, possible to occur to semiconductor products. Measures on the systems such as redundant design, arresting the spread of fire or preventing glitch are recommended in order to prevent physical injury, fire, social damages, for example, by using the products.
- (6) Comply with the instructions for use in order to prevent breakdown and characteristics change due to external factors (ESD, EOS, thermal stress and mechanical stress) at the time of handling, mounting or at customer's process. When using products for which damp-proof packing is required, satisfy the conditions, such as shelf life and the elapsed time since first opening the packages.
- (7) This book may be not reprinted or reproduced whether wholly or partially, without the prior written permission of Matsushita Electric Industrial Co., Ltd.



LittleDiode supplies new, hard to find or obsolete electronic components and semiconductors all over the world.

With over two million different components listed you are sure to find the part you need.

Feel free to visit us today at our online store:

LittleDiode.com

Looking forward to providing you with the best possible service.