

# AN5101SC

## VIF/SIF Signal Processor IC for TV and VCR

### Overview

The AN5101SC is a VIF/SIF signal processor IC for TV and VCR.

### Features

- Including a quasi-separate sound circuit for better audio performance
- Adopting the gated-PLL technique for better second-sound-channel buzz-beat characteristics (for sound multiplex broadcasting service) or enhancement of video over-modulation characteristics.
- Low power consumption :  $P_C = 240\text{mW}$  typ. at  $V_{CC} = 5.0\text{V}$

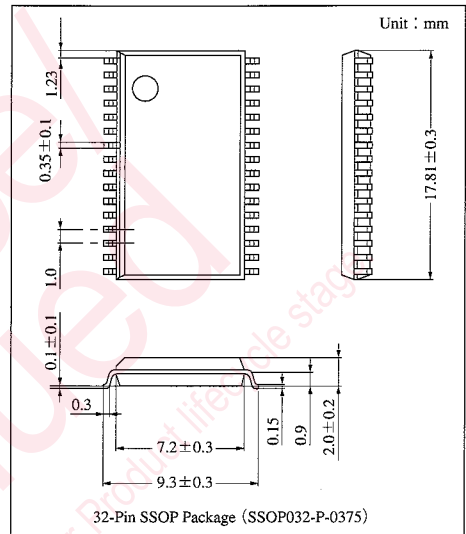

### Block Diagram

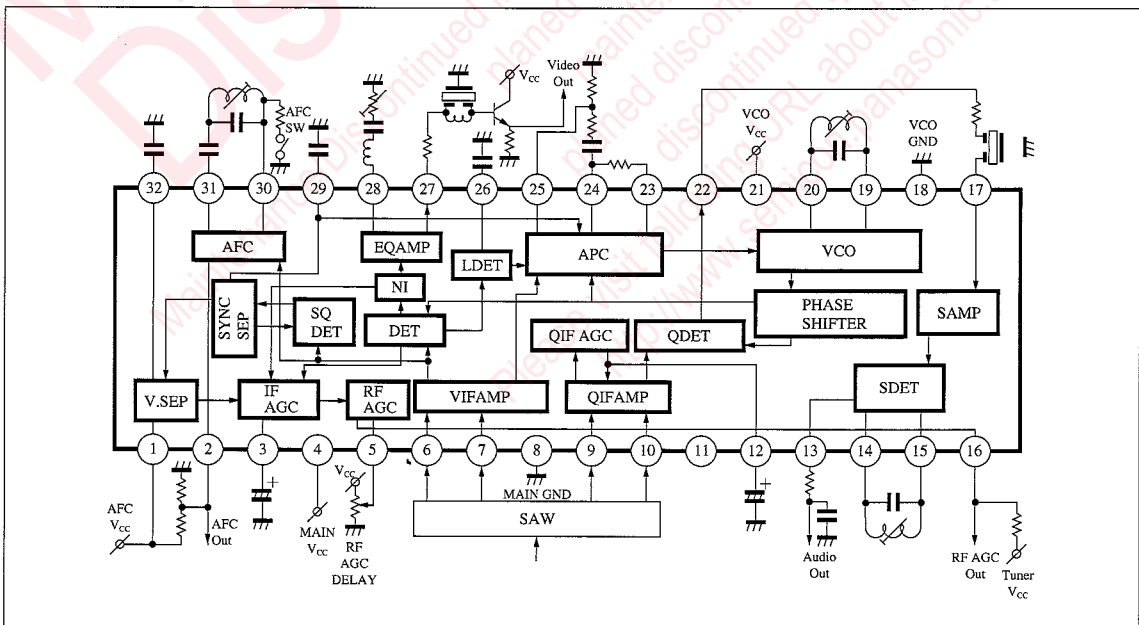

## Pin Descriptions

Pin No.	Pin name	Pin No.	Pin name
1	Power supply $V_{CC1}$ (for AFC output)	17	SIF input
2	AFC output	18	GND (for VCO)
3	VIF AGC filter	19	VCO coil
4	Power supply $V_{CC2}$ (for MAIN)	20	VCO coil
5	RF AGC DELAY adj.	21	Power supply $V_{CC3}$ (for VCO)
6	VIF input	22	QIF detection output
7	VIF input	23	APC detection output
8	GND (for MAIN)	24	VCO control
9	QIF input	25	APC time constant switching
10	QIF input	26	Lock detection
11	NC	27	Video detection output
12	QIF AGC filter	28	Feedback
13	Audio output	29	Sync. signal separation
14	SIF coil	30	AFC coil
15	SIF coil	31	AFC coil
16	RF AGC output	32	Vert. sync. signal separation

## Reference

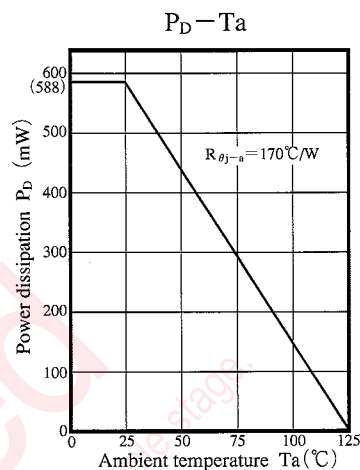

ICs for  
TV

## Absolute Maximum Ratings

Parameter	Symbol	Rating		Unit
Supply voltage	$V_{CC}$	$V_{CC2,3}$	6.0	V
		$V_{CC1}$	12.5	
Supply current	$I_{CC}$	$I_{CC2,3}$	65.0	mA
		$I_{CC1}$	1.8	
Circuit voltage	$V_{16-8,18}$	0 to 12.5		V
	$V_{25-8,18}$	0 to 12.5		V
Power dissipation <sup>Note 2)</sup>	$P_D$	320		mW
Operating ambient temperature <sup>Note 1)</sup>	$T_{opr}$	-20 to +70		$^{\circ}\text{C}$
Storage temperature <sup>Note 1)</sup>	$T_{stg}$	-55 to +125		$^{\circ}\text{C}$

Note 1)  $T_a = 25^{\circ}\text{C}$  except operating ambient temperature and storage temperature.

Note 2) Allowable power dissipation of the package at  $T_a = 70^{\circ}\text{C}$ .

## Recommended Operating Range ( $T_a = 25^{\circ}\text{C}$ )

Parameter	Symbol	Range
Operating supply voltage range	$V_{CC2,3}$	4.5V to 5.5V
	$V_{CC1}$	$V_{CC2,3}$ to 12.2V

**Electrical Characteristics** ( $V_{CC}=5V$ ,  $T_a=25\pm 2^\circ C$ )

Parameter	Symbol	Condition	min	typ	max	Unit
<b>VIF AMP DET Section</b>						
Video detection output	$V_{O27}$	Typical color signal (white color contained) $m=87.5\%$ , $v_{in}=80dB\mu$	1.7	2.0	2.3	$V_{P-P}$
Video frequency characteristics	$f_e$	Attenuation value at 8MHz	-4.0	-1.0	+0	dB
Synchronous peak voltage	$V_P$		1.1	1.3	1.5	V
<b>PLL Section</b>						
APC pull-in range <h>	$f_{Ph}$		1.0	—	—	MHz
APC pull-in range <I>	$f_{Pl}$		—	—	-1.0	MHz
VCO control sensitivity	$\beta$	$V_{24}=2.3$ to $2.5V$	1.5	2.0	2.5	kHz/mV
<b>AGC Section</b>						
RF AGC operation sensitivity	$v_{RF AGC}$		0	1.0	3.0	dB
RF AGC maximum pull-in current	$I_{16 max.}$		1.5	2.1	2.7	mA
RF AGC minimum pull-in current	$I_{16 min.}$		-3.0	0	3.0	$\mu A$
<b>AFC Section</b>						
AFC discrimination sensitivity	$\mu_{AFC}$	$R_L = 150k\Omega // 150k\Omega$	18	26	34	mV/kHz
AFC center voltage	$I_2$		5.0	6.0	7.0	V
AFC maximum output voltage	$V_{2max.}$	$f=f_0 - 500kHz$	10.5	11.2	—	V
AFC minimum output voltage	$V_{2min.}$	$f=f_0 + 500kHz$	—	0.7	1.5	V
<b>QIF AMP DET Section</b>						
QDET output level	$v_{QDET}$		95	100	105	dB $\mu$
<b>SIF Section</b>						
Sound detection output	$V_{O13}$	$f_0=4.5MHz$ $v_{in}=100dB\mu$ $df=\pm 25kHz$ $f_m=400Hz$ $R_D=6.8k\Omega$	327	385	443	mVrms
<b>DC Characteristics</b>						
Circuit current (1) (Pin④, Pin⑫)	$I_{4+21}$		36.5	46.5	56.5	mA
Circuit current (2) (Pin①)	$I_1$		0.8	1.1	1.4	mA
VIF input pin voltage	$V_{6,7}$		2.6	3.0	3.4	V
QIF input pin voltage	$V_{9,10}$		2.6	3.0	3.4	V
Audio output pin voltage	$V_{13}$		1.5	2.0	2.5	V
SIF coil pin voltage	$V_{14,15}$		4.0	4.2	4.5	V
SIF input pin voltage	$V_{17}$		1.2	1.5	1.8	V
VCO coil pin voltage	$V_{19,20}$		2.7	3.2	3.7	V
QDET output pin voltage	$V_{22}$		2.5	2.9	3.3	V
VCO control pin voltage	$V_{24}$		2.0	2.45	2.9	V
APC time constant switching pin	$V_{25}$		4.5	5.0	—	V
Video detection output pin voltage	$V_{27}$		3.2	3.7	4.2	V
AFC coil pin voltage	$V_{30,31}$		2.4	2.8	3.2	V
<b>VIF AMP DET Section</b>						
Input sensitivity	$v_{SV}$	$V_{O27} = -3dB$	—	(42)	(46)	dB $\mu$
Maximum tolerant input	$v_{max.v}$		(97)	(102)	—	dB $\mu$
SN ratio	S/N		(50)	(55)	—	dB
Differential gain	DG		—	(2)	(5)	%
Differential phase	DP		—	(2)	(5)	deg
Black noise detection level	$dV_{BN}$	$V_{BN} - V_P$	—	(-0.85)	—	V

Note) The characteristics value in parentheses is not a guaranteed value, but reference one on design.

**Electrical Characteristics (cont.)** ( $V_{CC}=5V$ ,  $T_a=25\pm 2^\circ C$ )

Parameter	Symbol	Condition	min	typ	max	Unit
Black noise clamp level	$\Delta V_{BNC}$	$V_{BNC} - V_P$	—	(0.6)	—	V
White noise clamp level	$\Delta V_{WNC}$	$V_{WNC} - V_P$	—	(1.9)	—	V
Intermodulation	IM		(45)	(50)	—	dB
Input resistance (Pin⑥)	$R_{i6}$		—	(1.2)	—	k $\Omega$
Input capacitance (Pin⑥)	$C_{i6}$		—	(3.2)	—	pF
Output resistance (Pin⑳)	$R_{O27}$		—	(10)	—	$\Omega$

## PLL Section

VCO maximum variable range (1)	$\Delta f_{VU}$	$V_{24}=1.0V$	(1.8)	—	—	MHz
VCO maximum variable range (2)	$\Delta f_{VD}$	$V_{24}=4.0V$	—	—	(-1.8)	MHz
VCO frequency SW ON drift	$\Delta f_{VON}$	3 minute after SW ON	(-0.1)	(0)	(+0.1)	MHz
VCO frequency temperature drift	$\Delta f_{VT}$	$-20^\circ C$ to $+70^\circ C$	—	(-0.2)	—	MHz
VCO reference oscillation level	$v_{VCO}$		(100)	(106)	(112)	dB $\mu$
VCO 2nd harmonics level	$v_{VCO2}$		—	(70)	—	dB $\mu$

## AGC Section

RFAGC Delay point temperature drift	$\Delta v_{RFDT}$	$-20^\circ C$ to $+70^\circ C$	—	(+1)	—	dB
Noise canceller operation voltage (W)	$\Delta V_{NC(W)}$	$V_{NC(W)} - V_P$	—	(2.6)	—	V
Noise canceller operation voltage (B)	$\Delta V_{NC(B)}$	$V_{NC(B)} - V_P$	—	(-0.85)	—	V
IF AGC filter charge current	$I_{3C}$		(-15.0)	(-8.5)	(-4.0)	$\mu A$
IF AGC filter discharge current	$I_{3D}$		(340)	(470)	(600)	$\mu A$

## AFC Section

AFC defeat SW operation voltage	$V_{AFC-SW}$		—	(0.9)	—	V
---------------------------------	--------------	--	---	-------	---	---

## QIF AMP DET

Input sensitivity	$v_{SQ}$	$v_{QDET} = -3dB$	—	(46)	(50)	dB $\mu$
Maximum tolerant input	$v_{max,Q}$		(99)	(104)	—	dB $\mu$
Input resistance (Pin⑨)	$R_{i9}$	$f=54.25MHz$	—	(1.2)	—	k $\Omega$
Input capacitance (Pin⑨)	$C_{i9}$	$f=54.25MHz$	—	(3.2)	—	pF
Output resistance (Pin㉑)	$R_{O22}$	$f=4.5MHz$	—	(170)	—	$\Omega$

## SIF Section

Input limiting voltage	$v_{i(lim)}$	$V_{O13} = -3dB$	—	(37)	—	dB $\mu$
AM rejection ratio	AMR	$v_{in}=90dB\mu$	(45)	(55)	—	dB
Total harmonics distortion	THD		—	(0.15)	—	%
Input resistance (Pin⑰)	$R_{i17}$	$f=4.5MHz$	—	(1.1)	—	k $\Omega$
Input capacitance (Pin⑰)	$C_{i17}$	$f=4.5MHz$	—	(8.0)	—	pF
Detector input resistance (Pin⑬)	$R_{i13}$	$f=4.5MHz$	—	(10)	—	k $\Omega$
Detector input capacitance (Pin⑬)	$C_{i13}$	$f=4.5MHz$	—	(25)	—	pF
Output resistance (Pin⑱)	$R_{O12}$	$f=500kHz$	—	(400)	—	$\Omega$

Note) The characteristics value in parentheses is not a guaranteed value, but reference one on design.

ICs for  
TV

## Request for your special attention and precautions in using the technical information and semiconductors described in this book

- (1) If any of the products or technical information described in this book is to be exported or provided to non-residents, the laws and regulations of the exporting country, especially, those with regard to security export control, must be observed.
- (2) The technical information described in this book is intended only to show the main characteristics and application circuit examples of the products. No license is granted in and to any intellectual property right or other right owned by Panasonic Corporation or any other company. Therefore, no responsibility is assumed by our company as to the infringement upon any such right owned by any other company which may arise as a result of the use of technical information described in this book.
- (3) The products described in this book are intended to be used for standard applications or general electronic equipment (such as office equipment, communications equipment, measuring instruments and household appliances).  
Consult our sales staff in advance for information on the following applications:
  - Special applications (such as for airplanes, aerospace, automobiles, traffic control equipment, combustion equipment, life support systems and safety devices) in which exceptional quality and reliability are required, or if the failure or malfunction of the products may directly jeopardize life or harm the human body.
  - Any applications other than the standard applications intended.
- (4) The products and product specifications described in this book are subject to change without notice for modification and/or improvement. At the final stage of your design, purchasing, or use of the products, therefore, ask for the most up-to-date Product Standards in advance to make sure that the latest specifications satisfy your requirements.
- (5) When designing your equipment, comply with the range of absolute maximum rating and the guaranteed operating conditions (operating power supply voltage and operating environment etc.). Especially, please be careful not to exceed the range of absolute maximum rating on the transient state, such as power-on, power-off and mode-switching. Otherwise, we will not be liable for any defect which may arise later in your equipment.
  - Even when the products are used within the guaranteed values, take into the consideration of incidence of break down and failure mode, possible to occur to semiconductor products. Measures on the systems such as redundant design, arresting the spread of fire or preventing glitch are recommended in order to prevent physical injury, fire, social damages, for example, by using the products.
- (6) Comply with the instructions for use in order to prevent breakdown and characteristics change due to external factors (ESD, EOS, thermal stress and mechanical stress) at the time of handling, mounting or at customer's process. When using products for which damp-proof packing is required, satisfy the conditions, such as shelf life and the elapsed time since first opening the packages.
- (7) This book may be not reprinted or reproduced whether wholly or partially, without the prior written permission of our company.



LittleDiode supplies new, hard to find or obsolete electronic components and semiconductors all over the world.

With over two million different components listed you are sure to find the part you need.

Feel free to visit us today at our online store:

[LittleDiode.com](http://LittleDiode.com)

Looking forward to providing you with the best possible service.