

AN5177NK

VIF/SIF Signal Processor IC for TV and VCR

■ Overview

The AN5177NK is a VIF/SIF signal processor IC for TV and VCR.

■ Features

- PLL full-synchronization detection
- An equalization amplifier for improved frequency characteristics built-in
- Low operating voltage : $V_{CC}=5.0V$ (typ.)

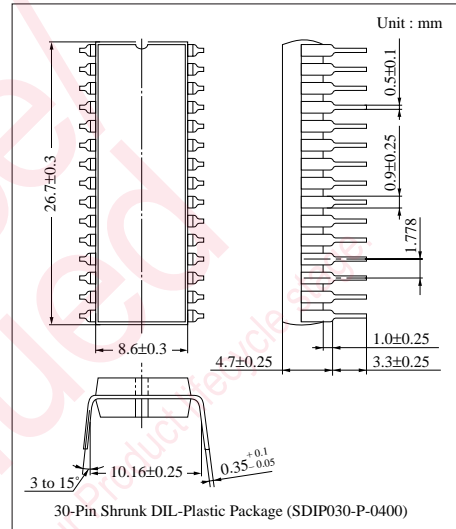

■ Block Diagram

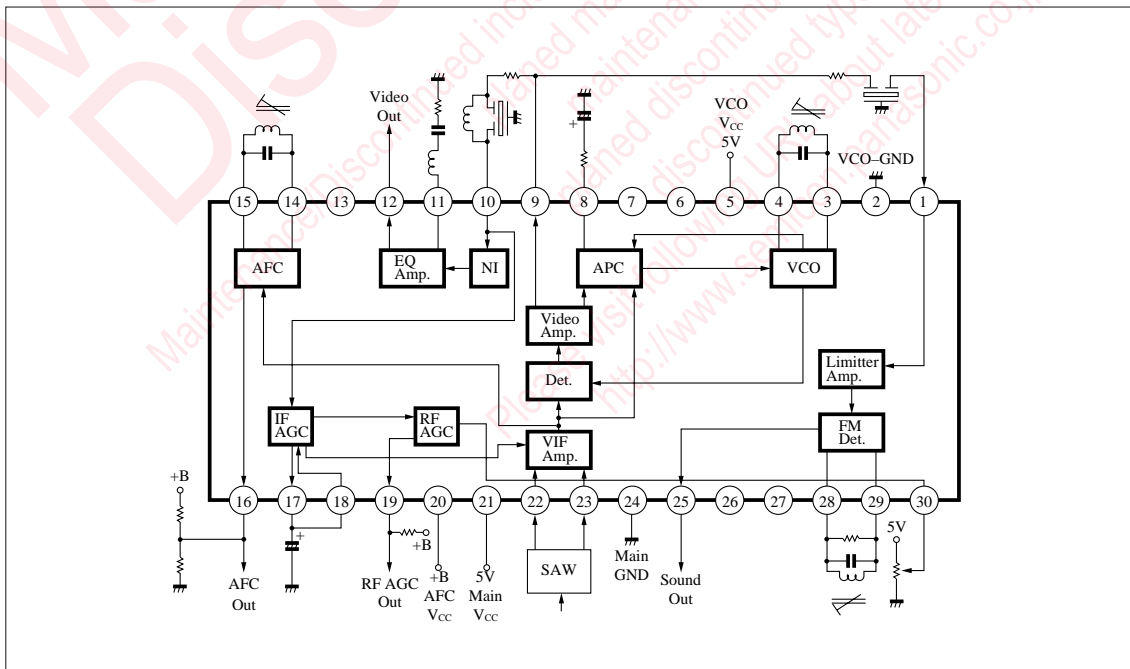

■ Pin Descriptions

Pin No.	Pin name	Pin No.	Pin name
1	SIF input	16	AFC output
2	GND	17	IF AGC filter
3	VCO coil	18	IF AGC filter
4	VCO coil	19	RF AGC output
5	Power supply	20	AFC output power supply
6	NC	21	Power supply
7	NC	22	VIF input
8	APC filter	23	VIF input
9	VIF detection output	24	GND
10	NOISE INVERTER input	25	Audio output
11	Frequency characteristics Adj.	26	NC
12	Video output	27	NC
13	NC	28	SIF coil
14	AFC coil	29	SIF coil
15	AFC coil	30	RF AGC DELAY Adj.

■ Absolute Maximum Ratings

Parameter	Symbol	Rating		Unit
		$V_{5,21-2,24}$	$V_{20-2,24}$	
Supply voltage	V_{CC}	6.0	12.5	V
Supply current	I_{CC}	100		mA
	I_9	- 8 to + 1		
Circuit current	I_{12}	- 5 to + 0.2		mA
	I_{19}	0 to + 2.0		
	I_{25}	- 2.5 to + 0.2		
Power dissipation ^{Note 2)}	P_D	600		mW
Operating ambient temperature ^{Note 1)}	T_{opr}	- 20 to + 70		°C
Storage temperature ^{Note 1)}	T_{stg}	- 55 to + 150		°C
Circuit voltage	$V_{19-2,24}$	0 to 12.5		V

Note 1) $T_a=25^\circ\text{C}$ except operating ambient temperature and storage temperature.

Note 2) Allowable power dissipation of the package at $T_a=70^\circ\text{C}$.

■ Recommended Operating Range ($T_a=25^\circ\text{C}$)

Parameter	Symbol	Range
Operating supply voltage range	V_{CC1} ($V_{5,21-2,24}$)	4.5V to 5.5V
	V_{CC2} ($V_{20-2,24}$)	V_{CC1} to 12.2V

■ Electrical Characteristics (Ta=25±2°C)

Parameter	Symbol	Condition	min	typ	max	Unit
VIF AMP DET Section						
Video detection output	V _{O12}	Typical color signal (white color contained) m= 87.5%, v _{in} =80dBμ	1.9	2.2	2.5	V _{P-P}
Video frequency characteristics (1)	f _{C(1)}	Attenuation value at 8MHz	- 6.0	- 2.5	+1.0	dB
Synchronous peak voltage	V _P		0.9	1.1	1.3	V
PLL Section						
APC pull-in range <h>	f _{ph}		1.2	—	—	MHz
APC pull-in range <l>	f _{pl}		—	—	-1.2	MHz
VCO control sensitivity	β	V ₈ = 2.0 to 2.2V	2.5	4.0	5.5	kHz/mV
APC detection sensitivity	μ _{APC}	f= f ₀ ±500kHz	0.2	0.3	0.4	mV/kHz
AGC Section						
IF AGC filter charge current	I _{17C}		- 20.0	-10.0	-5.0	μA
IF AGC filter discharge current	I _{17D}		400	550	700	μA
RF AGC operating sensitivity	v _{RF AGC}		0	1.5	3.0	dB
RF AGC pin current (1)	I ₁₉₍₁₎		—	—	1.38	mA
RF AGC pin current (2)	I ₁₉₍₂₎		- 0.15	0	0.15	mA
AFC Section						
AFC discrimination sensitivity (1)	μ _{1AFC}	R _L = 68kΩ//82kΩ	25	35	45	mV/kHz
AFC offset current (1)	I ₁₆₍₁₎		-17	-1	15	μA
AFC offset current (2)	I ₁₆₍₂₎		-12	+7	+26	μA
AFC maximum output voltage	V _{CC2} -V _{16max.}	f= f ₀ -500kHz	- 0.9	- 0.65	0	V
AFC minimum output voltage	V _{16min.}	f= f ₀ +500kHz	0	0.5	0.8	V
SIF Section						
Sound detection output	V _{O25}	f ₀ = 4.5MHz, v _{in} = 100dBμ Δf= ±25kHz, f _m = 400Hz RD= 6.8kΩ	240	300	360	mVrms
DC Characteristics						
Circuit current (Pin5, Pin20) (Pin21)	I ₅₊₂₀₊₂₁		41	59	77	mA
SIF input pin voltage	V ₁		4.9	5.0	5.1	V
VCO coil pin voltage	V _{3,4}		1.3	1.9	2.4	V
APC filter pin voltage	V ₈		1.6	2.1	2.6	V
VIF detection output pin voltage	V ₉		1.95	2.5	2.95	V
Video output pin voltage	V ₁₂		3.4	3.9	4.4	V
AFC coil pin voltage	V _{14,15}		2.1	2.5	2.9	V
VIF input pin voltage	V _{22,23}		2.65	2.95	3.25	V
Audio output pin voltage	V ₂₅		1.4	1.9	2.4	V
SIF coil pin voltage	V _{28,29}		2.4	3.0	3.7	V
VIF AMP DET Section						
Input sensitivity	v _{SV}	V _{O12} = - 3dB	—	(45)	(48)	dBμ
Maximum tolerant input	v _{max.v}		(97)	(102)	—	dBμ
Video frequency characteristics (2)	f _{C(2)}	V _{O12} = - 3dB	(7)	(9)	(11)	MHz
SN ratio	S/N		(50)	(55)	—	dB
Differential gain	DG		—	(2)	(5)	%
Differential phase	DP		—	(2)	(5)	deg
Black noise detection level	DV _{BN}	V _{BN} -V _P	(- 0.9)	(- 0.7)	(- 0.5)	V
Black noise clamp level	DV _{BNC}	V _{BNG} -V _P	(0.5)	(0.8)	(1.1)	V

Note) The characteristics value in parentheses is not a guaranteed value, but reference one on design.

■ Electrical Characteristics (cont.) (Ta=25±2°C)

Parameter	Symbol	Condition	min	typ	max	Unit
White noise clamp level	ΔV_{WNC}	$V_{WNG} - V_P$	(1.9)	(2.2)	(2.5)	V
Intermodulation	IM		(43)	(49)	—	dB
Input resistance (Pin22)	R_{i22}		—	(1.1)	—	k Ω
Input capacitance (Pin22)	C_{i22}		—	(3.2)	—	pF
Output resistance (Pin9)	R_{o9}		—	(30)	—	Ω
Output resistance (Pin12)	R_{o12}		—	(10)	—	Ω
PLL Section						
VCO maximum variable range (1)	Δf_{VU}	$V_8 = 1.0V$	(1.5)	—	—	MHz
VCO maximum variable range (2)	Δf_{VD}	$V_8 = 3.4V$	—	—	(2.0)	MHz
VCO frequency SW ON drift	Δf_{VON}	3 minute after SW ON	(-0.1)	(0)	(+0.1)	MHz
VCO frequency temperature drift	Δf_{VT}	-20°C to +70°C	—	(-0.3)	—	MHz
VCO reference oscillation level	v_{VCO}		(100)	(106)	(112)	dB μ
VCO 2nd harmonics level	v_{VCO2}		—	(70)	—	dB μ
AGC Section						
RF AGC Delay point temperature drift	Δv_{RFDT}	-20°C to +70°C	—	(+2)	—	dB
Noise canceller operation voltage (W)	$\Delta V_{NC(W)}$	$V_{NC(W)} - V_P$	(2.9)	(3.2)	(3.5)	V
Noise canceller operation voltage (B)	$\Delta V_{NC(B)}$	$V_{NC(B)} - V_P$	(-0.9)	(-0.7)	(-0.5)	V
AFC Section						
AFC defeat SW operation voltage	V_{AFC-SW}		(0.6)	(0.9)	(1.2)	V
AFC discrimination sensitivity (2)	μ_{2AFC}	$v_{in} = 71dB\mu$	(10)	(18)	(24)	mV/kHz
AFC offset current (3)	$I_{16(3)}$		(-11)	(+8)	(+28)	μA
SIF Section						
Input limiting voltage	v_i (lim)	$V_{025} = -3dB$	—	(46)	—	dB μ
AM rejection ratio (1)	AMR (1)	$v_{in} = 100dB\mu$	(45)	(60)	—	dB
AM rejection ratio (2)	AMR (2)	$v_{in} = 80dB\mu$	(30)	(35)	—	dB
Total harmonics distortion	THD		(0)	(0.3)	—	%
Input resistance (Pin1)	R_{i1}	$f = 4.5MHz$	—	(1.0)	—	k Ω
Input capacitance (Pin1)	C_{i1}	$f = 4.5MHz$	—	(8.0)	—	pF
Detector input resistance (Pin28)	R_{i28}	$f = 4.5MHz$	—	(3.5)	—	k Ω
Detector input capacitance (Pin28)	C_{i28}	$f = 4.5MHz$	—	(25)	—	pF
Output resistance (Pin25)	R_{o25}	$f = 500kHz$	—	(500)	—	Ω

Note) The characteristics value in parentheses is not a guaranteed value, but reference one on design.

Request for your special attention and precautions in using the technical information and semiconductors described in this book

- (1) If any of the products or technical information described in this book is to be exported or provided to non-residents, the laws and regulations of the exporting country, especially, those with regard to security export control, must be observed.
- (2) The technical information described in this book is intended only to show the main characteristics and application circuit examples of the products, and no license is granted under any intellectual property right or other right owned by our company or any other company. Therefore, no responsibility is assumed by our company as to the infringement upon any such right owned by any other company which may arise as a result of the use of technical information described in this book.
- (3) The products described in this book are intended to be used for standard applications or general electronic equipment (such as office equipment, communications equipment, measuring instruments and household appliances).
Consult our sales staff in advance for information on the following applications:
 - Special applications (such as for airplanes, aerospace, automobiles, traffic control equipment, combustion equipment, life support systems and safety devices) in which exceptional quality and reliability are required, or if the failure or malfunction of the products may directly jeopardize life or harm the human body.
 - Any applications other than the standard applications intended.
- (4) The products and product specifications described in this book are subject to change without notice for modification and/or improvement. At the final stage of your design, purchasing, or use of the products, therefore, ask for the most up-to-date Product Standards in advance to make sure that the latest specifications satisfy your requirements.
- (5) When designing your equipment, comply with the range of absolute maximum rating and the guaranteed operating conditions (operating power supply voltage and operating environment etc.). Especially, please be careful not to exceed the range of absolute maximum rating on the transient state, such as power-on, power-off and mode-switching. Otherwise, we will not be liable for any defect which may arise later in your equipment.
 - Even when the products are used within the guaranteed values, take into the consideration of incidence of break down and failure mode, possible to occur to semiconductor products. Measures on the systems such as redundant design, arresting the spread of fire or preventing glitch are recommended in order to prevent physical injury, fire, social damages, for example, by using the products.
- (6) Comply with the instructions for use in order to prevent breakdown and characteristics change due to external factors (ESD, EOS, thermal stress and mechanical stress) at the time of handling, mounting or at customer's process. When using products for which damp-proof packing is required, satisfy the conditions, such as shelf life and the elapsed time since first opening the packages.
- (7) This book may be not reprinted or reproduced whether wholly or partially, without the prior written permission of Matsushita Electric Industrial Co., Ltd.



LittleDiode supplies new, hard to find or obsolete electronic components and semiconductors all over the world.

With over two million different components listed you are sure to find the part you need.

Feel free to visit us today at our online store:

LittleDiode.com

Looking forward to providing you with the best possible service.