

AN5441S

Deflection distortion correction IC

■ Overview

The AN5441S is a distortion correction processing IC for deflection system of color televisions and wide screen televisions.

■ Features

- Distortion correcting functions
 - Vertical amplitude
 - Vertical linearity
 - Vertical S-shape
 - Vertical position
 - Vertical EHT
 - Horizontal amplitude
 - EW parabola
 - Trapezoidal
 - Upper/lower EW corner
 - Horizontal EHT
- Built-in horizontal and vertical blanking pulse generation circuit
- Supports I²C bus control

■ Applications

- Color televisions and wide screen televisions

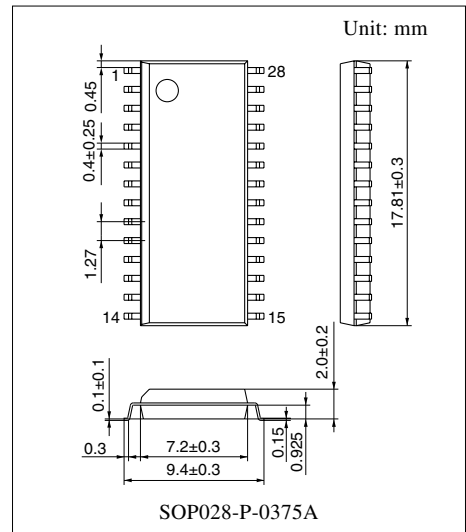

Note) The package of this product will be changed to lead-free type (SOP028-P-0375E). See the new package dimensions section later of this datasheet.

■ Block Diagram

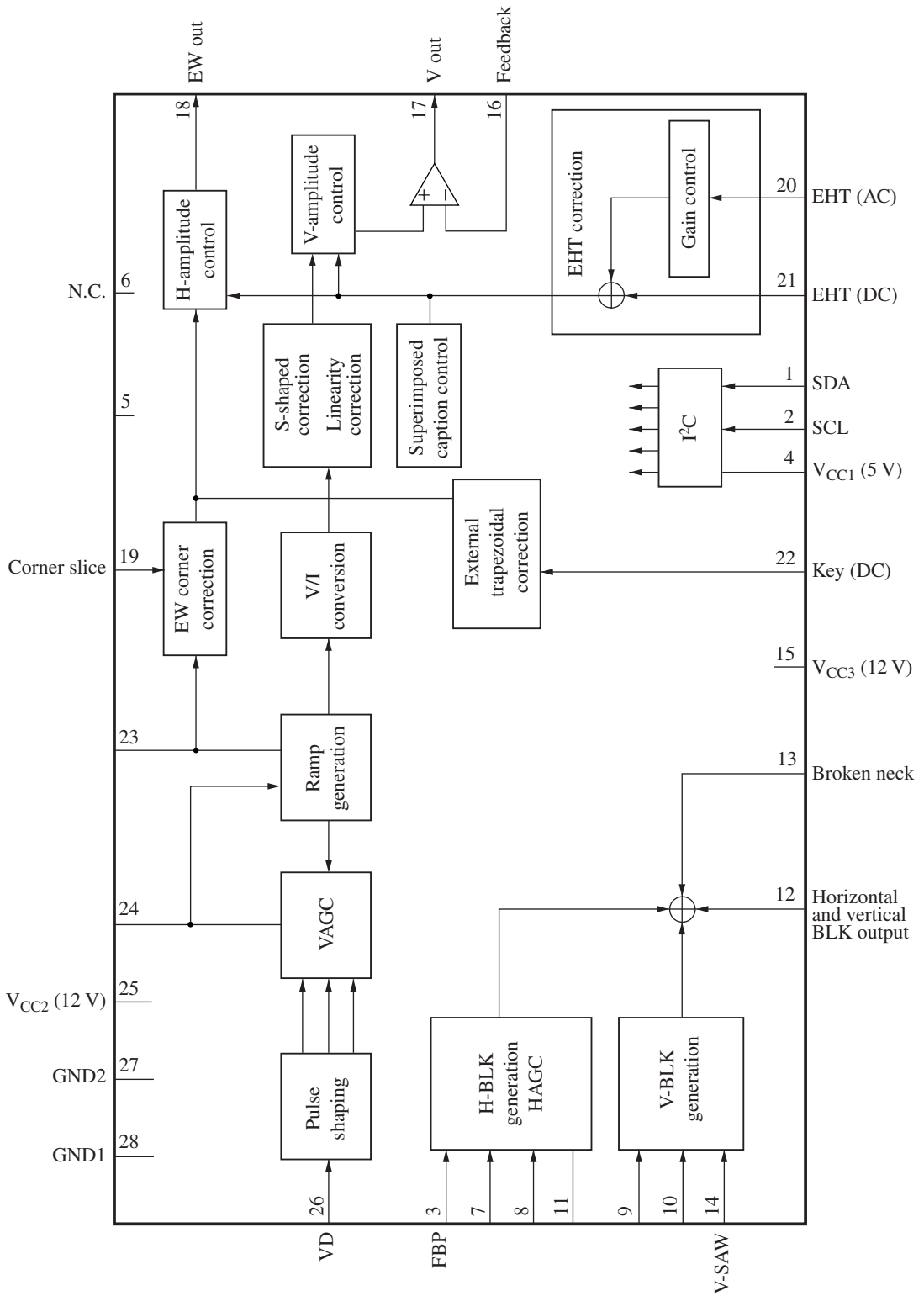

■ Pin Descriptions

Pin No.	Description	Pin No.	Description
1	I ² C SDA input	15	V _{CC3} (12 V)
2	I ² C SCL input	16	Vertical feedback input
3	Horizontal FBP input	17	Vertical pre-drive output
4	V _{CC1} (5 V)	18	EW output
5	Test pin	19	Corner slice voltage
6	N.C.	20	EHT-AC input
7	H-BLK high-level slice voltage	21	EHT-DC input
8	H-BLK low-level slice voltage	22	Control for keystone correction
9	V-BLK high-level slice voltage	23	Capacitor for ramp generation
10	V-BLK low-level slice voltage	24	Capacitor for V-AGC
11	Capacitor for H-AGC	25	V _{CC2} (12 V)
12	Horizontal and vertical BLK output	26	VD pulse input
13	Broken neck detection	27	GND2
14	V-BLK sawtooth input	28	GND1

■ Absolute Maximum Ratings

Parameter	Symbol		Rating	Unit
Supply voltage	V _{CC}	V _{CC1}	5.6	V
		V _{CC2} , V _{CC3}	13.4	
Supply current	I _{CC}	I _{CC1}	24.5	mA
		I _{CC2}	24.0	
		I _{CC3}	3.2	
Power dissipation *2	P _D		449	mW
Operating ambient temperature *2	T _{opr}		-20 to +70	°C
Storage temperature *1	T _{stg}		-55 to +150	°C

Note) *1 : Except for the operating ambient temperature and storage temperature, all ratings are for T_a = 25°C.

*2 : The power dissipation shown is the value for T_a = 70°C.

■ Recommended Operating Range

Parameter	Symbol	Range	Unit
Supply voltage	V _{CC1}	4.5 to 5.5	V
	V _{CC2}	10.8 to 13.2	
	V _{CC3}	10.8 to 13.2	

■ Electrical Characteristics at $T_a = 25^\circ\text{C}$

Parameter	Symbol	Conditions	Min	Typ	Max	Unit
Circuit current I_{CC1}	I_4	$V_{CC1} = 5\text{ V}, V_{CC2} = 12\text{ V}, V_{CC3} = 12\text{ V}$	11.7	17.0	20.2	mA
Circuit current I_{CC2}	I_{25}	$V_{CC1} = 5\text{ V}, V_{CC2} = 12\text{ V}, V_{CC3} = 12\text{ V}$	13.1	16.6	20.2	mA
Circuit current I_{CC3}	I_{15}	$V_{CC1} = 5\text{ V}, V_{CC2} = 12\text{ V}, V_{CC3} = 12\text{ V}$	1.8	2.1	2.3	mA
EHT-AC input pin voltage	$V_{20-27, 28}$	$V_{CC1} = 5\text{ V}, V_{CC2} = 12\text{ V}, V_{CC3} = 12\text{ V}$	2.6	3.0	3.4	V
Vertical pull-in frequency 1	f_{V1}	$f_V = 50\text{ Hz}$ input	45	50	55	Hz
Vertical pull-in frequency 2	f_{V2}	$f_V = 60\text{ Hz}$ input	55	60	65	Hz
Typical vertical output amplitude	$e_{V(\text{typ})}$	typ.	2.3	2.7	3.1	V[p-p]
Typical EW output amplitude	$e_{E(\text{typ})}$	typ.	1.42	1.82	2.22	V[p-p]
Vertical BLK output pulse width	t_{VB}	Wide	3.3	4.8	6.2	ms
Horizontal BLK output pulse width 1	$t_{HB(1)}$	Normal	11.7	12.2	12.7	μs
Horizontal BLK output pulse width 2	$t_{HB(2)}$	Wide	37	39	41	μs
Vertical output amplitude change ratio (max.)	$\frac{e_{V(\text{max})}}{e_{V(\text{typ})}}$	V amplitude typ. \rightarrow max. ratio	42	48	54	%
Vertical output amplitude change ratio (min.)	$\frac{e_{V(\text{min})}}{e_{V(\text{typ})}}$	V amplitude typ. \rightarrow min. ratio	-54	-48	-42	%
Vertical output S-shape change ratio 1	Δe_{VS1}	Vertical S-shape min. \rightarrow max. ratio	-20	-13	-6	%
Vertical output S-shape change ratio 2	Δe_{VS2}	Vertical S-shape min. \rightarrow max. ratio (change of V out 40% to 60% point)	—	1.5	6.0	%
Vertical output (upper side) linearity change ratio 1	Δe_{VC1}	Vertical linearity (upper side) typ. \rightarrow max.	6	10	14	%
Vertical output (upper side) linearity change ratio 2	Δe_{VC2}	Vertical linearity (upper side) typ. \rightarrow max.	-14	-10	-6	%
Vertical output position change amount (max.)	$\Delta e_{VP(\text{max})}$	Vertical position typ. \rightarrow max.	-1.0	-0.8	-0.6	V
Vertical output position change amount (min.)	$\Delta e_{VP(\text{min})}$	Vertical position typ. \rightarrow min.	0.5	0.7	0.9	V
Vertical output (lower side) linearity change ratio 1	—	Vertical linearity (lower side) typ. \rightarrow max.	8	12	16	%
Vertical output (lower side) linearity change ratio 2	—	Vertical linearity (lower side) typ. \rightarrow min.	-16	-12	-8	%
Vertical output EHT-DC change	Δe_{VED}	EHT-DC = 6 V, vertical EHT, min. \rightarrow max.	-24.8	-21.8	-18.8	%
Vertical output EHT-AC change 1	$\Delta e_{VEA(1)}$	EHT-AC = 2V, VEHT: max., EHT gain, min. \rightarrow max.	-16	-12	-8	%
Vertical output EHT-AC change 2	$\Delta e_{VEA(2)}$	EHT-AC = 4 V, VEHT: max., EHT gain, min. \rightarrow max.	9	13	17	%
Vertical output superimposed caption change 1	$\Delta e_{VJ(1)}$	Vertical superimposed caption min. \rightarrow max.	-13	-10	-7	%
Vertical output superimposed caption change 2	$\Delta e_{VJ(2)}$	Vertical superimposed caption min. \rightarrow max., V amplitude typ. \rightarrow min.	-15	-11	-7	%

■ Electrical Characteristics at $T_a = 25^\circ\text{C}$ (continued)

Parameter	Symbol	Conditions	Min	Typ	Max	Unit
Vertical output amplitude (max.)	$\Delta e_{V(\max)}$	V amplitude max.	3.5	3.9	4.3	V
Vertical output amplitude (min.)	$\Delta e_{V(\min)}$	V amplitude min.	1.1	1.4	1.7	V
Vertical output center DC level	Δe_{VDC}	typ.	4.5	4.9	5.3	V
EW output parabolic amplitude change (min.)	$e_{E(\min)}$	Parabolic amplitude min.	0	0.1	0.5	V[p-p]
EW output parabolic amplitude change (max.)	$e_{E(\max)}$	Parabolic amplitude max.	2.5	3.5	4.5	V[p-p]
EW output horizontal amplitude change (min.)	$e_{ED(\min)}$	Horizontal amplitude min.	5.45	6.0	6.93	V
EW output horizontal amplitude change (max.)	$e_{ED(\max)}$	Horizontal amplitude max.	0.7	2.0	2.6	V
EW output trapezoidal change (min.)	$\Delta e_{ET(\min)}$	Trapzoidal SW : On, trapezoidal typ. → min.	64	96	126	%
EW output trapezoidal change (max.)	$\Delta e_{ET(\max)}$	Trapzoidal SW : On, trapezoidal typ. → max.	-130	-100	-68	%
EW output upper corner change (min.)	$\Delta e_{ECT(\min)}$	Upper corner min.	-95	-65	-35	%
EW output upper corner change (max.)	$\Delta e_{ECT(\max)}$	Upper corner max.	30	60	90	%
EW output lower corner change (min.)	$\Delta e_{ECB(\min)}$	Lower corner min.	-95	-65	-35	%
EW output lower corner change (max.)	$\Delta e_{ECB(\max)}$	Lower corner max.	25	55	85	%
EW output (bottom voltage) EHT-DC change	Δe_{EED}	EHT-DC: 6 V Horizontal EHT min. → max.	2.1	2.6	3.1	V
EW output (bottom voltage) EHT-AC change 1	$\Delta e_{EEA(1)}$	EHT-AC: 2 V, horizontal EHT: max., EHT gain min. → max.	1.2	1.4	1.6	V
EW output (bottom voltage) EHT-AC change 2	$\Delta e_{EEA(2)}$	EHT-AC: 4 V, horizontal EHT: max., EHT gain min. → max.	-1.8	-1.5	-1.2	V
EW output (EW amplitude) KEY change 1 (min.)	$\Delta e_{EK(\min1)}$	KEY = 2 V, trapezoidal SW: On, trapezoidal max. → min.	95	120	145	%
EW output (EW amplitude) KEY change 1 (max.)	$\Delta e_{EK(\max1)}$	KEY = 3.2 V, trapezoidal SW: On, trapezoidal min. → max.	-145	-120	-95	%
EW output parabolic DC level	e_{EB}	typ.	2.9	4.0	5.1	V
EW output (EW amplitude) KEY change 2 (min.)	$\Delta e_{EK(\min2)}$	KEY = 2 V, trapezoidal SW: Off, trapezoidal max. → min.	-145	-120	-95	%
EW output (EW amplitude) KEY change 2 (max.)	$\Delta e_{EK(\max2)}$	KEY = 3.2 V, trapezoidal SW: Off, trapezoidal min. → max.	95	120	145	%
EW output drive current 1	$I_{EW(1)}$	Pin 18: 11 V	0.7	1.1	1.5	mA
V-AGC input and output current	I_{VAGC}		0.5	0.8	1.1	mA
H-AGC input and output current	I_{HAGC}		0.7	1.0	1.3	mA

■ Electrical Characteristics at $T_a = 25^\circ\text{C}$ (continued)

Parameter	Symbol	Conditions	Min	Typ	Max	Unit
Ramp discharge current	I_{RD}		6.7	8.9	11.1	mA
Ramp charge current 1	$I_{RC(1)}$	Pin 24: 1 V	40	45	52	μA
Vertical output at service SW	V_{SSW}		4.55	4.95	5.35	V
Broken neck threshold voltage	V_{Neck}	Service SW: Off	0.5	0.7	0.9	V
BLK output amplitude	V_{BO}		2.8	3.1	3.4	V
H-AGC voltage 1	$V_{HAGC(1)}$	HD: 14 kHz	2.6	3.25	3.9	V
H-AGC voltage 2	$V_{HAGC(2)}$	HD: 17 kHz	3.1	3.85	4.6	V
H-AGC pulse width	f_{HA}	3 k Ω resistor between pin 11 and GND	1.5	2.2	3.0	μs
V-AGC pulse width	f_{VA}	3 k Ω resistor between pin 24 and GND	75	110	150	μs
EW output drive current 2	$I_{EW(2)}$	Pin 18: 1 V	-1.3	-0.9	-0.5	mA
Ramp charge current 2	$I_{RC(2)}$	Pin 24: 10 V	7	10	13	μA
H-AGC current ΔV	$V_{HAGC\Delta V}$	HD: 17 kHz ΔV	0.2	0.6	1.1	V
VD input threshold value	V_{VD}		0.9	1.3	1.7	V
FBP input threshold value	V_{FBP}		0.5	0.7	0.9	V
High-level I ² C SDA input	$V_{SDA(H)}$		4.0	—	V_{CC1}	V
low-level I ² C SDA input	$V_{SDA(L)}$		0	—	0.7	V
High-level I ² C SCL input	$V_{SCL(H)}$		4.0	—	V_{CC1}	V
Low-level I ² C SCL input	$V_{SCL(L)}$		0	—	0.7	V
Maximum input allowable frequency	$f_{i\max}$		100	—	—	kHz
Vertical output amplitude with supply voltage fluctuation	$\Delta e_{V-V_{CC}}$	Difference of $V_{CC(max)} - V_{CC(min)}$	0	0.1	0.5	V
Vertical output with DC supply voltage fluctuation	$\Delta e_{VD-V_{CC}}$	Difference of $V_{CC(max)} - V_{CC(min)}$	0.5	1.0	1.5	V
EW output amplitude with supply voltage fluctuation	$\Delta e_{E-V_{CC}}$	Difference of $V_{CC(max)} - V_{CC(min)}$	0	0.1	0.5	V
EW output with DC supply voltage fluctuation	$\Delta e_{ED-V_{CC}}$	Difference of $V_{CC(max)} - V_{CC(min)}$	0.4	1.0	1.6	V
Sink current at ACK	I_{ACK}	Maximum value of pin 1 sink current at ACK	—	2.5	—	mA
3-bit, 4-bit, 6-bit, 7-bit DAC DNLE	$L_{3, 4, 6, 7}$	1LSB = {data (max.) - data (00)} / 7, 15, 63, 127	0.1	1.0	1.9	LSB/step
Vertical output drive current	$I_{V\text{ Out}}$		7	11	15	mA

■ Terminal Equivalent Circuits

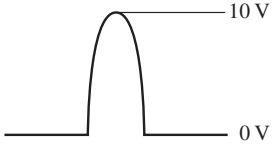
Pin No.	Equivalent circuit	Description	Voltage
1		I ² C bus data input pin: Sink current: typ. 2.5 mA	AC (Pulse)
2		I ² C bus clock input pin	AC (Pulse)
3		FBP input pin: 	AC (Pulse)
4	—	V _{CC1} (typ. 5 V): For I ² C circuit	DC 5 V
5		Test pin: Attach a capacitor (0.082 μF) for filter to GND.	DC 10.6 V

■ Terminal Equivalent Circuits (continued)

Pin No.	Equivalent circuit	Description	Voltage
6	—	N.C	N.C.
7		<p>HBLK high-level slice voltage:</p>	DC typ. 0 V to 4 V
8		<p>HBLK low-level slice voltage:</p>	DC typ. 0 V to 4 V
9		<p>VBLK high-level slice voltage: For I²C circuit</p>	DC typ. 0 V to 10 V
10		<p>VBLK low-level slice voltage:</p>	DC 0 V to 10 V

■ Terminal Equivalent Circuits (continued)

Pin No.	Equivalent circuit	Description	Voltage
11		H sawtooth AGC voltage pin	DC 1.5 V to 10 V
12		Blanking pulse output pin: Horizontal/vertical BLK output pin Blanking output high-level with neck input low-level	AC (Pulse)
13		Broken neck detection pin: Normal; High-level (apply 1 V or more) Abnormal; Low-level (apply 0.4 V or more) (Broken neck mode) There is no broken neck operation when service SW is on.	DC
14	Refer to pin 9 and pin 10 equivalent circuit.	Sawtooth input pin for V-BLK: 	AC
15	—	V_{CC3} (typ. 12 V): For BLK pulse generation circuit.	DC 12 V

■ Terminal Equivalent Circuits (continued)

Pin No.	Equivalent circuit	Description	Voltage
16		<p>Vertical feedback input pin:</p> <p>V out</p> <p>Short-circuit this pin with pin 17 in normal use</p>	AC
17		<p>Vertical output pin:</p> <p>V out</p> <p>Short-circuit this pin with pin 16 in normal use</p>	AC
18		<p>EW output pin:</p> <p>EW out</p>	AC
19		<p>Upper and lower corner slice voltage input pin</p>	DC 0 V to 1.5 V

■ Terminal Equivalent Circuits (continued)

Pin No.	Equivalent circuit	Description	Voltage
20		EHT-AC input pin	AC Open approx. 2.9 V
21		EHT-DC input pin	DC 6 V to 10 V (typ. 8 V)
22		External shape trapezoidal correction DC control pin	DC 1.5 V to 3.5 V (typ. 2.5 V)
23		Ramp reference waveform generation pin:	AC

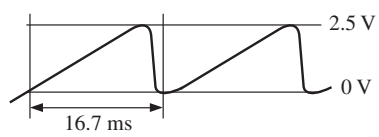

■ Terminal Equivalent Circuits (continued)

Pin No.	Equivalent circuit	Description	Voltage
24		AGC pin for ramp	AC
25	—	V_{CC2} (typ. 12 V): For I ² C circuit and correction system circuit	DC
26		V pulse input pin: 	AC (Pulse)
27	—	GND2: For analog circuit block	DC
28	—	GND1: For digital circuit block	DC

Application Circuit Example

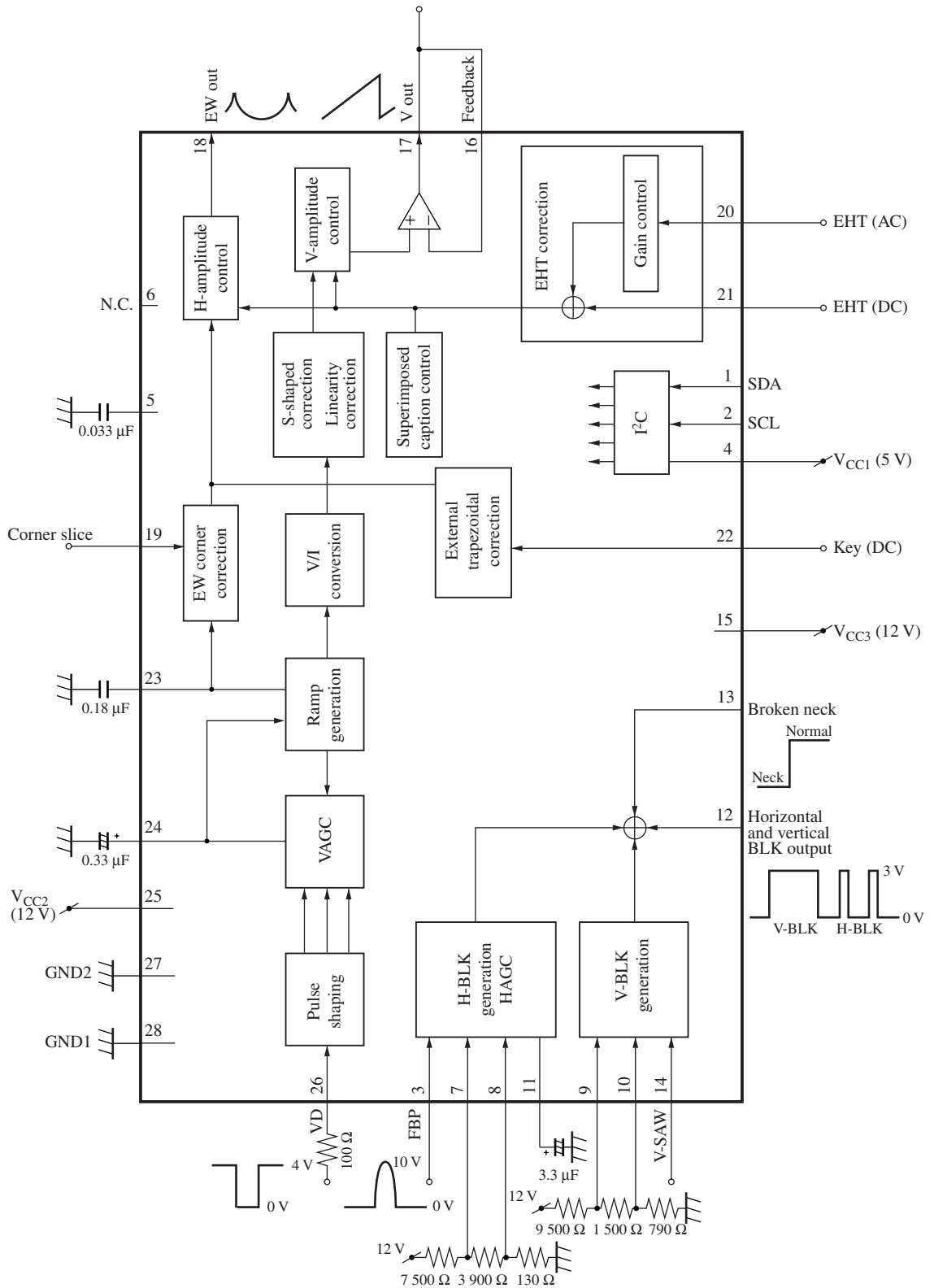

■ New Package Dimensions (Unit: mm)

- SOP028-P-0375E (Lead-free package)

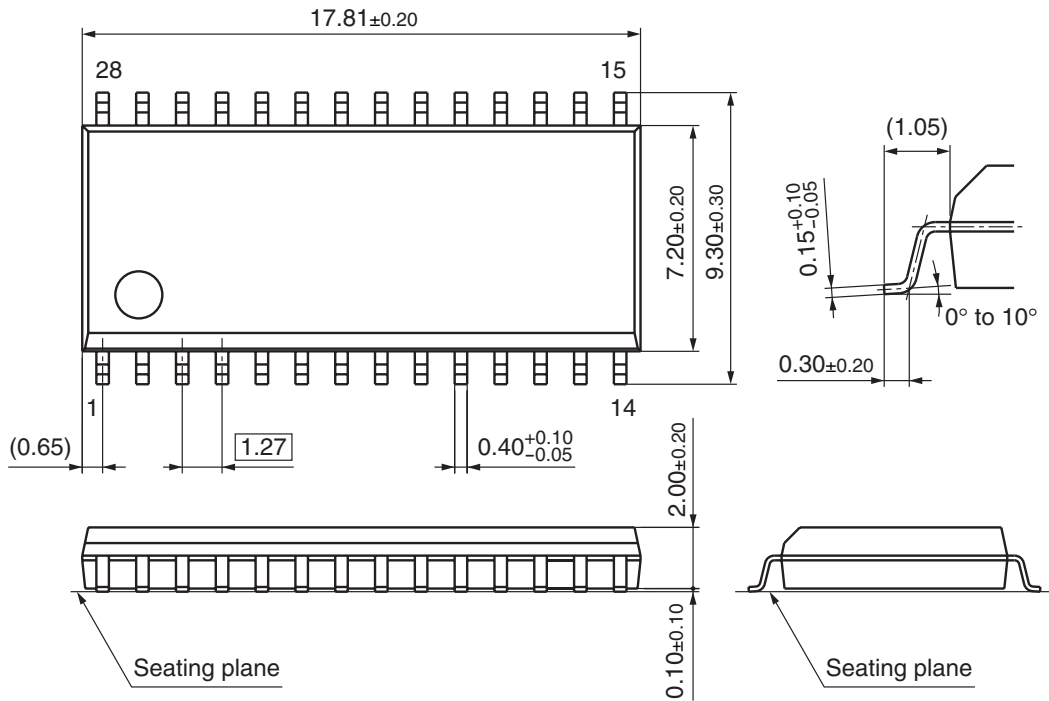

Request for your special attention and precautions in using the technical information and semiconductors described in this material

- (1) An export permit needs to be obtained from the competent authorities of the Japanese Government if any of the products or technologies described in this material and controlled under the "Foreign Exchange and Foreign Trade Law" is to be exported or taken out of Japan.
- (2) The technical information described in this material is limited to showing representative characteristics and applied circuit examples of the products. It does not constitute the warranting of industrial property, the granting of relative rights, or the granting of any license.
- (3) The products described in this material are intended to be used for standard applications or general electronic equipment (such as office equipment, communications equipment, measuring instruments and household appliances).
Consult our sales staff in advance for information on the following applications:
 - Special applications (such as for airplanes, aerospace, automobiles, traffic control equipment, combustion equipment, life support systems and safety devices) in which exceptional quality and reliability are required, or if the failure or malfunction of the products may directly jeopardize life or harm the human body.
 - Any applications other than the standard applications intended.
- (4) The products and product specifications described in this material are subject to change without notice for reasons of modification and/or improvement. At the final stage of your design, purchasing, or use of the products, therefore, ask for the most up-to-date Product Standards in advance to make sure that the latest specifications satisfy your requirements.
- (5) When designing your equipment, comply with the guaranteed values, in particular those of maximum rating, the range of operating power supply voltage and heat radiation characteristics. Otherwise, we will not be liable for any defect which may arise later in your equipment.
Even when the products are used within the guaranteed values, redundant design is recommended, so that such equipment may not violate relevant laws or regulations because of the function of our products.
- (6) When using products for which dry packing is required, observe the conditions (including shelf life and after-unpacking standby time) agreed upon when specification sheets are individually exchanged.
- (7) No part of this material may be reprinted or reproduced by any means without written permission from our company.

Please read the following notes before using the datasheets

- A. These materials are intended as a reference to assist customers with the selection of Panasonic semiconductor products best suited to their applications.
Due to modification or other reasons, any information contained in this material, such as available product types, technical data, and so on, is subject to change without notice.
Customers are advised to contact our semiconductor sales office and obtain the latest information before starting precise technical research and/or purchasing activities.
- B. Panasonic is endeavoring to continually improve the quality and reliability of these materials but there is always the possibility that further rectifications will be required in the future. Therefore, Panasonic will not assume any liability for any damages arising from any errors etc. that may appear in this material.
- C. These materials are solely intended for a customer's individual use.
Therefore, without the prior written approval of Panasonic, any other use such as reproducing, selling, or distributing this material to a third party, via the Internet or in any other way, is prohibited.



LittleDiode supplies new, hard to find or obsolete electronic components and semiconductors all over the world.

With over two million different components listed you are sure to find the part you need.

Feel free to visit us today at our online store:

LittleDiode.com

Looking forward to providing you with the best possible service.