

# AN5707NS

## TV Electronic Tuner-Control IC

### Overview

The AN5707NS is an integrated circuit for tuner-control circuit of auto-search-tuning system.

### Features

- Low supply-voltage operation ( $V_{CC}=4.2$  to  $5.5V$ )
- Low power consumption by Bi-CMOS Process (30mW typ.)
- Auto search by Up-Down Switch
- Bar display on the screen (tuning channel)

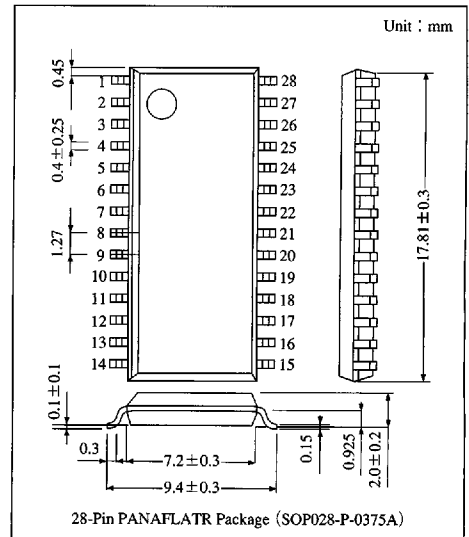

### Block Diagram

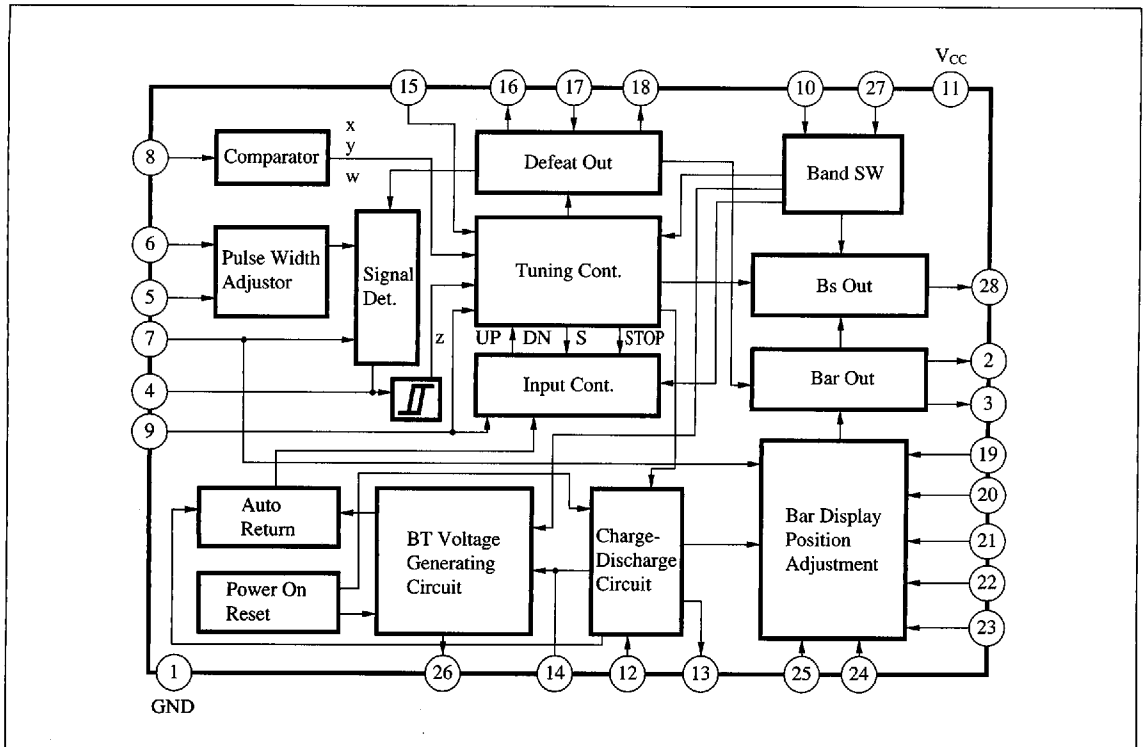

6932852 0014395 92T

### Absolute Maximum Ratings (Ta=25°C)

Parameter	Symbol	Rating	Unit
Supply voltage	V <sub>CC</sub>	6	V
Pin voltage	V <sub>28-1</sub>	10	V
Supply current	I <sub>CC</sub>	12	mA
Pin current	I <sub>2</sub>	-1 to 0	mA
	I <sub>3</sub>	-1 to 0	
	I <sub>26</sub>	-0.2 to +0.2	
	I <sub>28</sub>	0 to +2	
Power dissipation	P <sub>D</sub>	72	mW
Operating ambient temperature	T <sub>opr</sub>	-20 to +70	°C
Storage temperature	T <sub>stg</sub>	-40 to +125	°C

### Recommended Operating Range (Ta=25°C)

Parameter	Symbol	Range
Operating supply voltage range	V <sub>CC</sub>	4.2V to 5.5V

### Electrical Characteristics (Ta=25°C)

Parameter	Symbol	Condition				Unit
			min	typ	max	
Circuit current	I <sub>11</sub>	V <sub>CC</sub> =5V	4	6	8.5	mA
Pin voltage	V <sub>9-1</sub>	V <sub>CC</sub> =5V	2.2	2.5	2.8	V
Flyback pulse input threshold voltage	V <sub>TH6</sub>	V <sub>CC</sub> =5V	1	1.5	2.4	V
Horizontal synchronous signal input threshold voltage	V <sub>TH7</sub>	V <sub>CC</sub> =5V	2.6	3.1	3.6	V
BS output voltage "H"	V <sub>28-1(H)</sub>		9.1	9.5	—	V
BS output voltage "L"	V <sub>28-1(L)</sub>	I <sub>28</sub> =1mA	—	0.1	0.4	V
Tuning control (1)	V <sub>16-1(H)</sub>	Except the case during reception (S=0)	3.9	4.2	4.6	V
Tuning control (2)	V <sub>16-1(L)</sub>	During reception (S=1)	-0.2	0	0.2	V
Charging/discharging current (1)	I <sub>CHA(1)</sub>	V <sub>13-1</sub> =2.5V, during VHF search-up	-47	—	-20	μA
Charging/discharging current (2)	I <sub>CHA(2)</sub>	V <sub>13-1</sub> =2.5V, during VHF search-down	8	—	17.5	μA
Charging/discharging current (3)	I <sub>CHA(3)</sub>	V <sub>13-1</sub> =2.5V, during VHF tuning preparation (+)	-14	—	-5	μA
Charging/discharging current (4)	I <sub>CHA(4)</sub>	V <sub>13-1</sub> =2.5V, during VHF tuning preparation (-)	3.2	—	7.8	μA
Charging/discharging current (5)	I <sub>CHA(5)</sub>	V <sub>13-1</sub> =2.5V, during UHF search-up	-21.5	—	-9.5	μA
Charging/discharging current (6)	I <sub>CHA(6)</sub>	V <sub>13-1</sub> =2.5V, during UHF search-down	4.8	—	10.5	μA
Charging/discharging current (7)	I <sub>CHA(7)</sub>	V <sub>13-1</sub> =2.5V, during UHF tuning preparation (+)	-4	—	-1.6	μA
Charging/discharging current (8)	I <sub>CHA(8)</sub>	V <sub>13-1</sub> =2.5V, during UHF tuning preparation (-)	1.4	—	3.8	μA
Channel call input threshold voltage	V <sub>TH17</sub>	V <sub>CC</sub> =5V	1.9	2.4	2.9	V
Output saturation voltage	V <sub>CE(sat)</sub> (Pin⑧)	I <sub>18</sub> =300 μA	—	0.1	0.4	V
BT amp. characteristics VHFL (1)	V <sub>26-1(1)</sub>	V <sub>14-1</sub> =1.5V	-0.2	0	0.2	V
BT amp. characteristics VHFL (2)	V <sub>26-1(2)</sub>	V <sub>14-1</sub> =3.5V	3.9	4.25	4.6	V
BT amp. inclination (1) VHF <sub>L</sub>	ΔV <sub>26-1(1)</sub>	V <sub>14-1</sub> =2.8-2.2V	2.1	2.45	2.8	V
BT amp. characteristics (1) UHF	V <sub>26-1(3)</sub>	V <sub>14-1</sub> =2V	-0.2	0	0.2	V
BT amp. characteristics (2) UHF	V <sub>26-1(4)</sub>	V <sub>14-1</sub> =5V	4	4.3	4.6	V
BT amp. inclination (2) UHF	ΔV <sub>26-1(2)</sub>	V <sub>14-1</sub> =3.4-2.8V	0.5	0.85	1.2	V
BT amp. inclination (3)	ΔV <sub>26-1(2)</sub>	V <sub>14-1</sub> =4.4-4V	0.7	1.1	1.5	V

ICs for TV

6932852 0014396 866

Panasonic













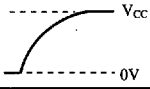

### Pin Descriptions

Pin No.	Pin name	Typ. waveform	Description	I/O impedance	Equivalent circuit
1	GND		GND pin.	—	
2	Bar display output (VHF)		Outputs a pulse of positive polarity for bar display at the time of VHF reception.	500 Ω	
3	Bar display output (UHF)		Outputs a pulse of positive polarity for bar display at the time of UHF reception.	500 Ω	
4	Signal detection		Determines the presence/absence of a TV signal by the DC voltage of this pin. Connect the CR filter externally.	High impedance	
5	H.P. waveform shaping mono/multi		Filter pin for H.P. pulse-waveform shaping circuit. The output pulse width is changed by the CR of time constant.	High impedance	
6	Flyback pulse input		Input a horizontal flyback pulse (positive polarity) to detect a signal.	56k Ω	
7	Horizontal signal input		Input a horizontal synchronous separation signal (positive polarity) to detect a signal.	68k Ω	
8	AFC input		Filter the AFC signal for input, which is significant for search tuning.	< 1M Ω	
9	Search-up/-down input		Search-up is started when this pin is set to V <sub>CC</sub> and search-down is started when it is set to GND.	100k Ω	
10	Lch/hch switching voltage input		Lch/Hch switching point setting pin. Lch/Hch of VHF is automatically switched.	100k Ω	
11	Supply voltage		Supply current is 6mA and the operating supply voltage range is 4.2 to 5.5V. V <sub>CC</sub> should be regulated before use.	—	
12	Search speed adjustment		The search speed is varied with constant-current to be input to this pin.	7k Ω	

ICs for TV

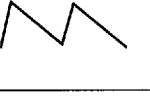
### Pin Descriptions (cont.)

Pin No.	Pin name	Typ. waveform	Description	I/O impedance	Equivalent circuit
13	Charging capacitor connection	—	Pin for generating MANU (14) voltage in auto search. Insert the capacitor of about $47\mu\text{F}$ with great care of leak.	High impedance	
14	BT voltage generation (Manual)	—	Pin for generating BT voltage (25) in manual search. Should be opened in auto search.	$> 1\text{k}\Omega$	
15	Temporary stop capacitor connection		Insert the capacitor of about $4.7\mu\text{F}$ between this pin and GND in order to stop temporarily at the tuned channel during auto search.	$100\text{k}\Omega$	
16	Defeat output	—	Used for switching of audio defeat, and of time constant of AFC filter, etc. Search : H, Tuning : OPEN	—	
17	Channel call	—	A channel display bar appears when this pin is set to GND and does not appear when it is set to $V_{\text{CC}}$ .	$10\text{k}\Omega$	
18	Bright output	—	Pin for darkening the screen when a channel display bar appears, and this pin is connected to the brightness volume. Search : 0V, Tuning : OPEN	—	
19	Bar display position adjustment (1)	—	Pin for adjusting the position of a channel-display-bar at the time of VHF reception. The position of a channel-display-bar is varied with the DC voltage to be given to this pin.	$< 100\text{k}\Omega$	
20	Bar display position adjustment (2)	—	Pin for adjusting the position of a channel-display-bar at the time of VHF Lch reception. The position of a channel-display-bar is varied with the DC voltage to be given to this pin.	$< 100\text{k}\Omega$	
21	Bar display position adjustment (3)	—	Pin for adjusting the position of a channel-display-bar at the time of VHF Hch reception. The position of a channel-display-bar is varied with the DC voltage to be given to this pin.	$< 100\text{k}\Omega$	
22	Filter		To generate a sawtooth wave for determining the position of a channel-display-bar. Insert the capacitor of about $560\text{pF}$ between this pin and GND.	—	
23	Bar display position adjustment (4)	—	Pin for determining the amplitude, on the panel, of a channel-display-bar at the time of VHF reception (the position of a display bar on the panel when the highest channel is received). The amplitude is varied with the quantity of current flowing out of this pin.	—	

## Pin Descriptions (cont.)

Pin No.	Pin name	Typ. waveform	Description	I/O impedance	Equivalent circuit
24	Bar display position adjustment (5)	—	Pin for determining the amplitude, on the panel, of a channel-display-bar at the time of VHF Hch reception (the position of a display bar on the panel when the highest channel is received). The amplitude is varied with the quantity of current flowing out of this pin.	—	
25	Bar display position adjustment (6)	—	Pin for determining the amplitude, on the panel, of a channel-display-bar at the time of VHF Lch reception (the position of a display bar on the panel when the highest channel is received). The amplitude is varied with the quantity of current flowing out of this pin.	—	
26	BT voltage generation	—	Pin for outputting BT-voltage for tuner. Compensation of tuner-characteristics is applied.	12kΩ	
27	U/V switching	—	UHF/VHF switching pin. V <sub>CC</sub> .....VHF GND or OPEN.....UHF	24kΩ	
28	BS output	—	Tuner BS output pin, which is opened-collector output. Used at 10V or less.	—	

Band	VHF		UHF
	Lch :	Hch :	
BS	OPEN	0V	0V

ICs for TV

## Supplementary Explanation

### Design Reference Value of Electrical Characteristics (T<sub>a</sub>=25°C)

Parameter	Symbol	Condition	min	typ	max	Unit
AFC threshold voltage (1)	V <sub>AFC</sub> (1)	V <sub>CC</sub> =5V	—	3.75	4.1	V
AFC threshold voltage (2)	V <sub>AFC</sub> (2)	V <sub>CC</sub> =5V	—	3.1	—	V
AFC threshold voltage (3)	V <sub>AFC</sub> (3)	V <sub>CC</sub> =5V	2.6	2.9	—	V
Search-up threshold voltage	V <sub>TH9</sub> (U)	V <sub>CC</sub> =5V	—	3.5	4	V
Search-down threshold voltage	V <sub>TH9</sub> (D)	V <sub>CC</sub> =5V	1	1.5	—	V

Note) The value in the above characteristics is not a guaranteed value, but reference one on design.

## Characteristic Curve

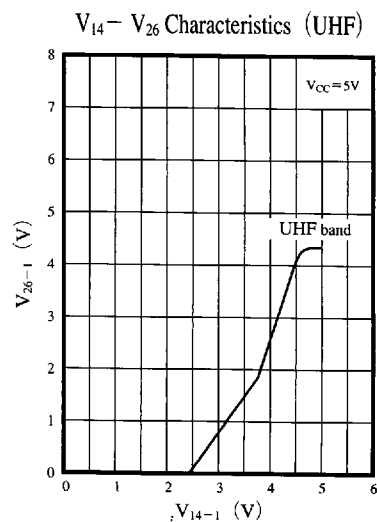
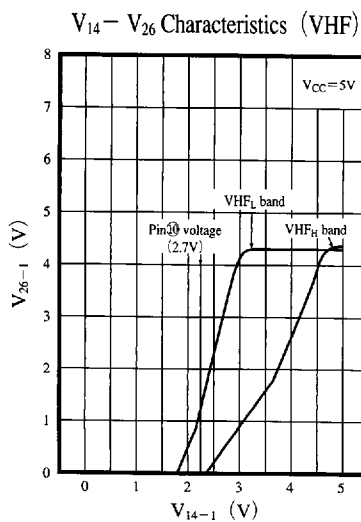



LittleDiode supplies new, hard to find or obsolete electronic components and semiconductors all over the world.

With over two million different components listed you are sure to find the part you need.

Feel free to visit us today at our online store:

[LittleDiode.com](http://LittleDiode.com)

Looking forward to providing you with the best possible service.