

AN5769

H/V convergence correction IC

■ Overview

The AN5769 is an IC to correct convergence in horizontal and vertical directions. It is possible to allow ± 100 mA (max.) DC current flow by connecting a coil between the output pins which operate with the reverse phase each other.

■ Features

- DC control input 0 V to 5 V
- Output dynamic range 1.2 V to 3.8 V
- Maximum output current ± 100 mA

■ Applications

- CRT monitors

■ Block Diagram

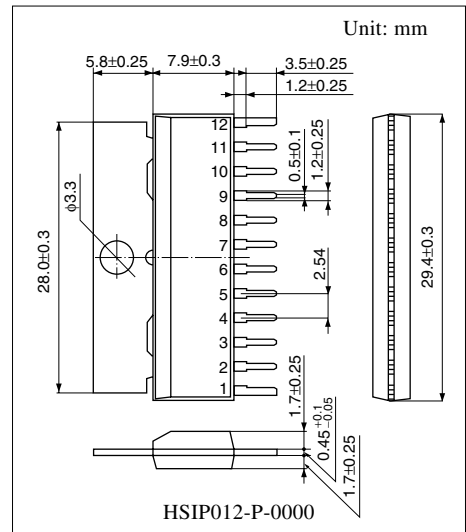
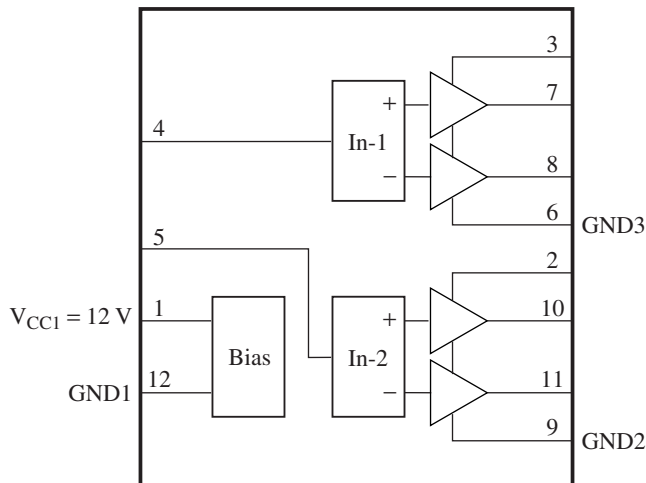

Note) The package of this product will be changed to lead-free type (HSIP012-P-0000D). See the new package dimensions section later of this datasheet.

■ Pin Descriptions

Pin No.	Description	Pin No.	Description
1	Power supply 12 V (V_{CC1})	6	Output block GND (GND3)
2	Output block power supply 7 V (V_{CC2}), protection resistor is required.	7	H-conv. positive output
		8	H-conv. negative output
3	Output block power supply 7 V (V_{CC3}), protection resistor is required.	9	Output block GND (GND2)
		10	V-conv. positive output
4	H-conv. control input	11	V-conv. negative output
5	V-conv. control input	12	GND (GND1)

■ Absolute Maximum Ratings

Parameter	Symbol	Rating	Unit
Supply voltage	V_{CC1}	13.5	V
	V_{CC2}	11.05	
	V_{CC3}	11.05	
Supply current	I_{CC1}	28	mA
	I_{CC2}	150	
	I_{CC3}	150	
Power dissipation ^{*2}	P_D	1 171	mW
Operating ambient temperature ^{*1}	T_{opr}	-25 to +75	°C
Storage temperature ^{*1}	T_{stg}	-55 to +150	°C

Note) 1. *1: Except for the operating ambient temperature and storage temperature, all ratings are for $T_a = 25^\circ\text{C}$.

*2: The power dissipation shown is for the IC package at $T_a = 75^\circ\text{C}$.

2. Pay attention to a breakdown to be caused by static electricity for pin 1.

3. Observe the following order of the supply power start-up:

- Turn-on order First: Pin 2, pin 3 on (7 V) power supply
 Second: Pin 1 on (12 V) power supply
- Turn-off order First: Pin 1 off (12 V) power supply
 Second: Pin 2, pin 3 off (7 V) power supply

■ Recommended Operating Range

Parameter	Symbol	Range	Unit
Supply voltage	V_{CC1}	10.8 to 13.2	V
	V_{CC2}	6.0 to 9.0	
	V_{CC3}	6.0 to 9.0	

■ Electrical Characteristics at $T_a = 25^\circ\text{C}$

Parameter	Symbol	Conditions	Min	Typ	Max	Unit
Circuit current 1	I_{CC1}	$V_{CC1} = 12\text{ V}, V_{CC2} = V_{CC3} = 7\text{ V}$	17	22	27	mA
Circuit current 2	I_{CC2}	$V_{CC1} = 12\text{ V}, V_{CC2} = V_{CC3} = 7\text{ V}$	—	0	1	mA
Circuit current 3	I_{CC3}	$V_{CC1} = 12\text{ V}, V_{CC2} = V_{CC3} = 7\text{ V}$	—	0	1	mA
Circuit voltage 7	V_{7-6}	$V_{CC1} = 12\text{ V}, V_{CC2} = V_{CC3} = 7\text{ V}$	2.8	3.0	3.2	V
Circuit voltage 8	V_{8-6}	$V_{CC1} = 12\text{ V}, V_{CC2} = V_{CC3} = 7\text{ V}$	2.8	3.0	3.2	V
Circuit voltage 10	V_{10-9}	$V_{CC1} = 12\text{ V}, V_{CC2} = V_{CC3} = 7\text{ V}$	2.8	3.0	3.2	V
Circuit voltage 11	V_{11-9}	$V_{CC1} = 12\text{ V}, V_{CC2} = V_{CC3} = 7\text{ V}$	2.8	3.0	3.2	V
H-conv. output voltage 1	E_{H1}	$V_7 - V_8$ at $V_4 = 2.5\text{ V}$	-0.15	0	+0.15	V
H-conv. output voltage 2	E_{H2}	$V_7 - V_8$ at $V_4 = 5\text{ V}$	+2.3	+2.5	+2.7	V
H-conv. output voltage 3	E_{H3}	$V_7 - V_8$ at $V_4 = 0\text{ V}$	-2.7	-2.5	-2.3	V
V-conv. output voltage 1	E_{V1}	$V_{10} - V_{11}$ at $V_5 = 2.5\text{ V}$	-0.15	0	+0.15	V
V-conv. output voltage 2	E_{V2}	$V_{10} - V_{11}$ at $V_5 = 5\text{ V}$	+2.3	+2.5	+2.7	V
V-conv. output voltage 3	E_{V3}	$V_{10} - V_{11}$ at $V_5 = 0\text{ V}$	-2.7	-2.5	-2.3	V

• Design reference data

Note) The characteristics listed below are theoretical values based on the IC design and are not guaranteed.

Parameter	Symbol	Conditions	Min	Typ	Max	Unit
High-level H-conv. output fluctuation with supply voltage	$\Delta E_{H/VCCH}$	ΔE with V_{CC1} change 12 V to 13.2 V, and V_{CC2}, V_{CC3} from 7 V to 9 V	-0.1	—	+0.1	V
Low-level H-conv. output fluctuation with supply voltage	$\Delta E_{H/VCCL}$	ΔE with V_{CC1} change 12 V to 10.8 V, and V_{CC2}, V_{CC3} from 7 V to 6 V	-0.1	—	+0.1	V
High-level V-conv. output fluctuation with supply voltage	$\Delta E_{V/VCCH}$	ΔE with V_{CC1} change 12 V to 13.2 V, and V_{CC2}, V_{CC3} from 7 V to 9 V	-0.1	—	+0.1	V
Low-level V-conv. output fluctuation with supply voltage	$\Delta E_{V/VCCL}$	ΔE with V_{CC1} change 12 V to 10.8 V, and V_{CC2}, V_{CC3} from 7 V to 6 V	-0.1	—	+0.1	V
H-conv. output fluctuation with temperature	$\Delta E_{H/Ta}$	ΔE with T_a change from $+25^\circ\text{C}$ to $+70^\circ\text{C}$ and with T_a change from $+25^\circ\text{C}$ to -20°C	-0.1	—	+0.1	V
V-conv. output fluctuation with temperature	$\Delta E_{V/Ta}$	ΔE with T_a change from $+25^\circ\text{C}$ to $+70^\circ\text{C}$ and with T_a change from $+25^\circ\text{C}$ to -20°C	-0.1	—	+0.1	V

■ Terminal Equivalent Circuits

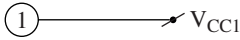
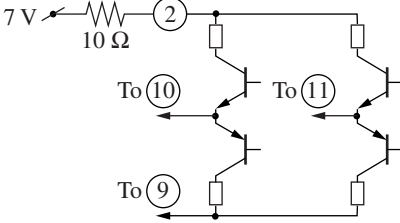
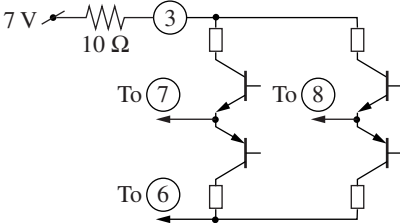
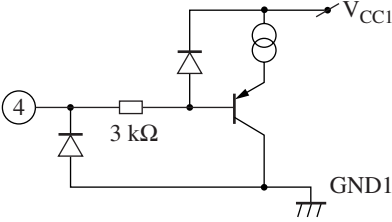
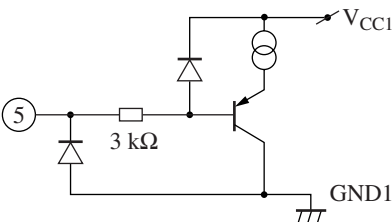
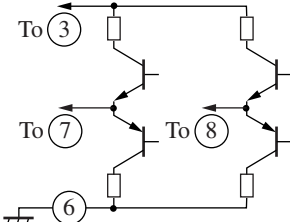
Pin No.	Equivalent circuit	Description	DC voltage (V)
1		Power supply 12 V (V_{CC1}): Power supply pin Apply DC 12 V.	12
2		Output block power supply 7 V (V_{CC2}): Power supply pin for V-conv. output Apply DC 7 V via protective resistor.	7
3		Output block power supply 7 V (V_{CC3}): Power supply pin for H-conv. output Apply DC 7 V via protective resistor.	7
4		H-conv. control input: Control input for H-conv. Apply DC 0 V to 5 V. (typ. = 2.5 V)	—
5		V-conv. control input: Control input for V-conv. Apply DC 0 V to 5 V. (typ. = 2.5 V)	—
6		GND3: Grounding pin of H-conv. output block	0

■ Terminal Equivalent Circuits (continued)

Pin No.	Equivalent circuit	Description	DC voltage (V)
7		H-conv. positive output: Positive output pin for H-conv. Outputs polarity as same as that of pin 4.	1.7 to 4.2
8		H-conv. negative output: Negative output pin for H-conv. Outputs polarity opposite to that of pin 4.	1.7 to 4.2
9		GND2: Grounding pin of V-conv. output block	0
10		V-conv. positive output: Positive output pin for V-conv. Outputs polarity as same as that of pin 5.	1.7 to 4.2
11		V-conv. negative output: Negative output pin for V-conv. Outputs polarity opposite to that of pin 5.	1.7 to 4.2
12		GND1: Grounding pin for 12V-system	0

Request for your special attention and precautions in using the technical information and semiconductors described in this material

- (1) An export permit needs to be obtained from the competent authorities of the Japanese Government if any of the products or technologies described in this material and controlled under the "Foreign Exchange and Foreign Trade Law" is to be exported or taken out of Japan.
- (2) The technical information described in this material is limited to showing representative characteristics and applied circuit examples of the products. It does not constitute the warranting of industrial property, the granting of relative rights, or the granting of any license.
- (3) The products described in this material are intended to be used for standard applications or general electronic equipment (such as office equipment, communications equipment, measuring instruments and household appliances).
Consult our sales staff in advance for information on the following applications:
 - Special applications (such as for airplanes, aerospace, automobiles, traffic control equipment, combustion equipment, life support systems and safety devices) in which exceptional quality and reliability are required, or if the failure or malfunction of the products may directly jeopardize life or harm the human body.
 - Any applications other than the standard applications intended.
- (4) The products and product specifications described in this material are subject to change without notice for reasons of modification and/or improvement. At the final stage of your design, purchasing, or use of the products, therefore, ask for the most up-to-date Product Standards in advance to make sure that the latest specifications satisfy your requirements.
- (5) When designing your equipment, comply with the guaranteed values, in particular those of maximum rating, the range of operating power supply voltage and heat radiation characteristics. Otherwise, we will not be liable for any defect which may arise later in your equipment.
Even when the products are used within the guaranteed values, redundant design is recommended, so that such equipment may not violate relevant laws or regulations because of the function of our products.
- (6) When using products for which dry packing is required, observe the conditions (including shelf life and after-unpacking standby time) agreed upon when specification sheets are individually exchanged.
- (7) No part of this material may be reprinted or reproduced by any means without written permission from our company.

Please read the following notes before using the datasheets

- A. These materials are intended as a reference to assist customers with the selection of Panasonic semiconductor products best suited to their applications.
Due to modification or other reasons, any information contained in this material, such as available product types, technical data, and so on, is subject to change without notice.
Customers are advised to contact our semiconductor sales office and obtain the latest information before starting precise technical research and/or purchasing activities.
- B. Panasonic is endeavoring to continually improve the quality and reliability of these materials but there is always the possibility that further rectifications will be required in the future. Therefore, Panasonic will not assume any liability for any damages arising from any errors etc. that may appear in this material.
- C. These materials are solely intended for a customer's individual use.
Therefore, without the prior written approval of Panasonic, any other use such as reproducing, selling, or distributing this material to a third party, via the Internet or in any other way, is prohibited.



LittleDiode supplies new, hard to find or obsolete electronic components and semiconductors all over the world.

With over two million different components listed you are sure to find the part you need.

Feel free to visit us today at our online store:

LittleDiode.com

Looking forward to providing you with the best possible service.