

AN5829S

Sound multiplex decoder IC for the U.S. televisions

■ Overview

The AN5829S is a multiplex sound demodulation IC dedicated to the U.S. television and incorporates a bi-directional I²C interface (adjustment, mode SW), an AGC circuit and external stereo input switches (2 systems).

■ Features

- Stereo demodulation, SAP demodulation, dbx noise reduction, AGC, external stereo input SW and I²C bus interface are integrated in a single chip
- Bi-directional I²C bus makes it possible to monitor MPX input level, separation adjustment (3 places), mode changeover and receiving status.
- Eliminated external parts (multi-sound block: 21 pieces → 14 pieces)
- Lower power dissipation ($V_{CC} = 5\text{ V}$, $I_{TOT} = 18\text{ mA}$)

■ Applications

- Televisions and VCRs for the North American market

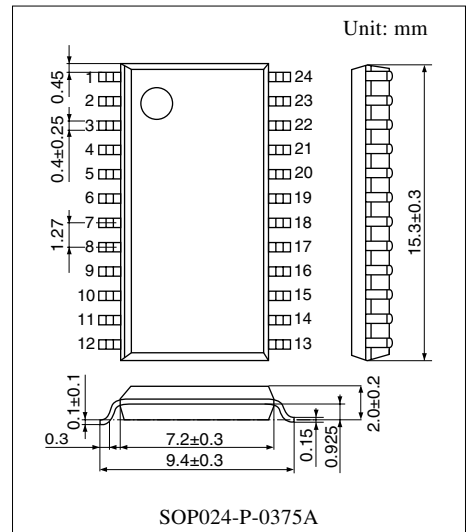

Note) The package of this product will be changed to lead-free type (SOP024-P-0375C). See the new package dimensions section later of this datasheet.

■ Block Diagram

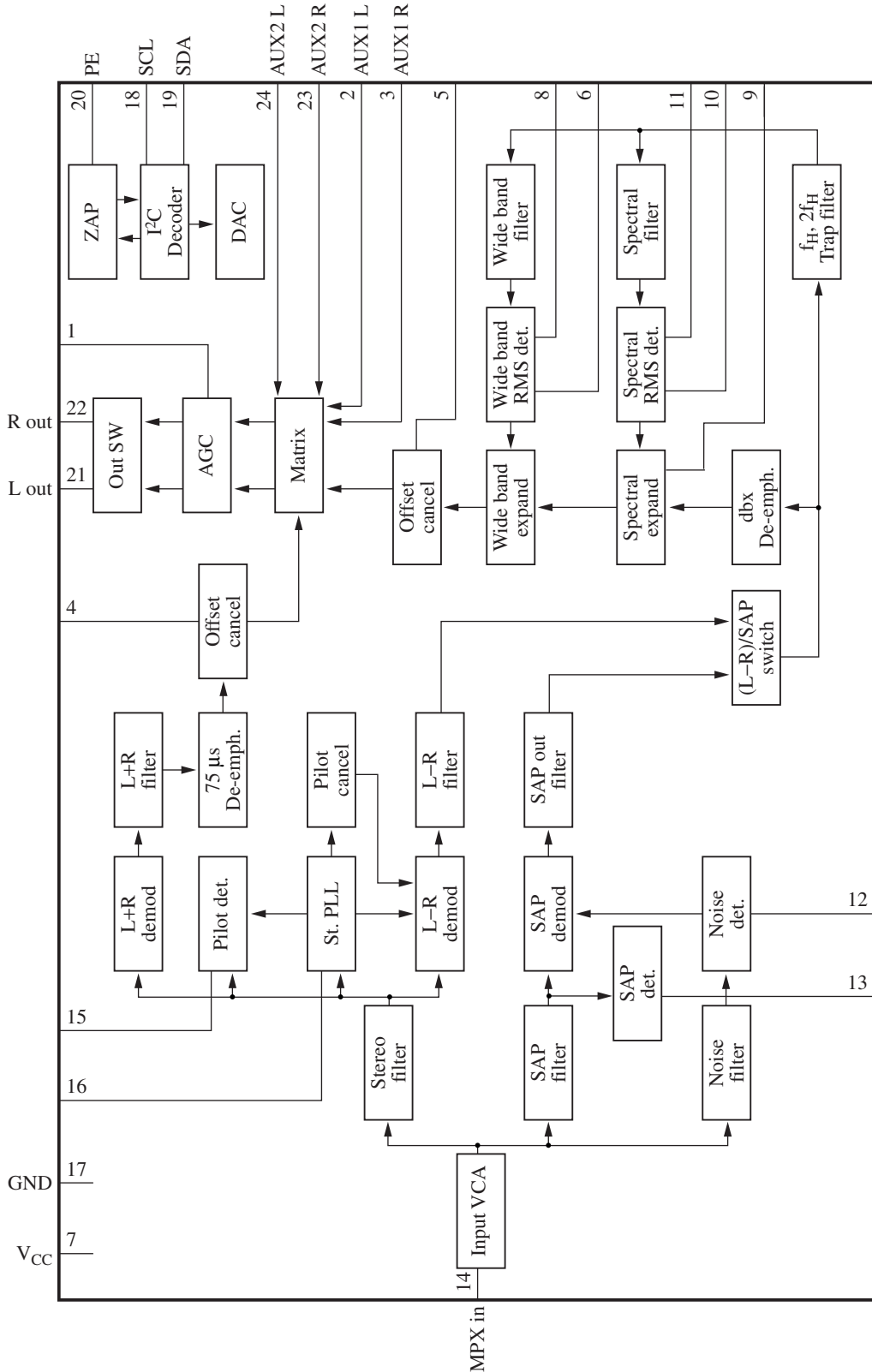

■ Pin Descriptions

Pin No.	Description	Pin No.	Description
1	AGC timing	13	SAP carrier detection
2	External input 1 L-ch	14	Composite input
3	External input 1 R-ch	15	Pilot signal detection
4	75 μ s filter offset cancel	16	Stereo PLL filter
5	dbx offset cancel	17	GND
6	Wideband timing	18	SCL
7	V _{CC}	19	SDA
8	Wideband level sensor input	20	PE for ZAP
9	Spectral filter	21	L-ch output
10	Spectral timing	22	R-ch output
11	Spectral level sensor input	23	External input 2 R-ch.
12	SAP noise level detection	24	External input 2 L-ch.

■ Absolute Maximum Ratings

Parameter	Symbol	Rating	Unit
Supply voltage	V _{CC}	6.0	V
Supply current	I _{CC}	25	mA
Power dissipation *2	P _D	150	mW
Operating ambient temperature *1	T _{opr}	-20 to +75	°C
Storage temperature *1	T _{stg}	-55 to +125	°C

Note) The use of this IC, which builds in dbx-TV noise reduction, requires a license agreement with THAT Corporation.

*1: Except for the operating ambient temperature and storage temperature, all ratings are for T_a = 25°C.

*2: T_a = 75°C

■ Recommended Operating Range

Parameter	Symbol	Range	Unit
Supply voltage	V _{CC}	4.5 to 5.5	V

■ Electrical Characteristics at $V_{CC} = 5\text{ V}$, NR: On, $T_a = 25^\circ\text{C}$

Input level (at 100% modulation) L+R: 75 mV[rms] (pre-emphasis off)

L-R: 150 mV[rms] (dbx noise reduction off)

Pilot: 15 mV[rms]

SAP: 45 mV[rms] (dbx noise reduction off)

Parameter	Symbol	Conditions	Min	Typ	Max	Unit
Total circuit current	I_{CC}	No signal	11	18	25	mA
Mono output level	$V_{0(MON)}$	$f = 1\text{ kHz}$, (mono) 100%mod	430	480	530	mV[rms]
Mono frequency characteristics-1	$V_{1(MON)}$	$f = 300\text{ Hz}$, (mono) 30%mod	-0.5	0	0.5	dB
Mono frequency characteristics-2	$V_{2(MON)}$	$f = 8\text{ kHz}$, (mono) 30%mod	-1.2	-0.1	0.7	dB
Mono distortion ratio	$THD_{(MON)}$	$f = 1\text{ kHz}$, (mono) 100%mod	—	—	0.7	%
Mono noise level	$V_{N(MON)}$	Input short-circuit, BPF (A curve)	—	—	-60	dBV
(L), (R) output voltage difference	$V_{LR(MON)}$	$f = 1\text{ kHz}$, (mono) 100%mod	-0.5	0	0.5	dB
Stereo output level	$V_{0(ST)}$	$f = 1\text{ kHz}$, (L(R)-only) 100%mod	380	480	580	mV[rms]
Stereo frequency characteristics-1	$V_{1(ST)}$	$f = 300\text{ Hz}$, (L(R)-only) 30%mod	-0.7	0	0.7	dB
Stereo frequency characteristics-2	$V_{2(ST)}$	$f = 3\text{ kHz}$, (L(R)-only) 30%mod	-1	0	1	dB
Stereo frequency characteristics-3	$V_{3(ST)}$	$f = 8\text{ kHz}$, (L(R)-only) 30%mod	-2.5	-0.5	1.5	dB
Stereo distortion ratio	$THD_{(ST)}$	$f = 1\text{ kHz}$, (L(R)-only) 100%mod	—	—	1	%
Stereo noise level	$V_{N(ST)}$	$f = 15.73\text{ kHz}$, (f_H), 15 mV[rms] $f_H \cdot 2 f_H$ Trap+BPF	—	—	-60	dBV
Stereo discrimination level	$V_{TH(ST)}$	$f = 15.73\text{ kHz}$ (f_H)	4	8	13	mV[rms]
Stereo discrimination hysteresis	$V_{HY(ST)}$	$f = 15.73\text{ kHz}$ (f_H)	0.5	—	5	dB
SAP output level	$V_{0(SAP)}$	$f = 1\text{ kHz}$, (SAP) 100%mod	370	500	680	mV[rms]
SAP frequency characteristics-1	$V_{1(SAP)}$	$f = 300\text{ Hz}$, (SAP) 30%mod	-1	0	1	dB
SAP frequency characteristics-2	$V_{2(SAP)}$	$f = 3\text{ kHz}$, (SAP) 30%mod	-2.5	-0.5	1	dB
SAP distortion ratio	$THD_{(SAP)}$	$f = 1\text{ kHz}$, (SAP) 100%	—	—	1.5	%
SAP noise level	$V_{N(SAP)}$	$f = 78.7\text{ kHz}$, ($5f_H$), $V = 45\text{ mV[rms]}$, BPF	—	—	-70	dBV
SAP discrimination level	$V_{TH(SAP)}$	$f = 78.7\text{ kHz}$, ($5f_H$)	11	—	26	mV[rms]
SAP discrimination hysteresis	$V_{HY(SAP)}$	$f = 78.7\text{ kHz}$, ($5f_H$)	0.5	—	5	dB
SAP → Stereo crosstalk	C_{T1}	(SAP) 1 kHz, 100%mod (Stereo) pilot-signal	—	—	-50	dB
Stereo → SAP crosstalk	C_{T2}	(Stereo) 1 kHz, 100%mod (SAP) carrier-signal	—	—	-50	dB
SAP → Mono crosstalk	C_{T3}	(SAP) 1 kHz, 100%mod	—	—	-50	dB
Mono → SAP crosstalk	C_{T4}	(Mono) 1 kHz, 100%mod (SAP) carrier-signal	—	—	-56	dB
AUX 1, AUX 2 to INT crosstalk	C_{T5}	$f = 1\text{ kHz}$, $V_{IN} = 500\text{ mV[rms]}$	—	—	50	dB
INT, AUX 2 to AUX 1 crosstalk	C_{T6}	INT: (mono) 1 kHz, 100%mod EXT: $f = 1\text{ kHz}$, 500 mV[rms]	—	—	50	dB
INT, AUX 1 to AUX 2 crosstalk	C_{T7}	INT: (mono) 1 kHz, 100%mod EXT: $f = 1\text{ kHz}$, 500 mV[rms]	—	—	50	dB

■ Electrical Characteristics at $V_{CC} = 5\text{ V}$, NR: On, $T_a = 25^\circ\text{C}$ (continued)

Parameter	Symbol	Conditions	Min	Typ	Max	Unit
AGC gain 1*1	V_{AGC1}	$f = 1\text{ kHz}$, $V_{IN(EXT)} = 50\text{ mV[rms]}$	67	100	140	mV[rms]
AGC gain 2*1	V_{AGC2}	$f = 1\text{ kHz}$, $V_{IN(EXT)} = 500\text{ mV[rms]}$	180	270	390	mV[rms]
I² C interface						
Sink current at ACK	I_{ACK}	Maximum pin 2 sink current at ACK	1	2	20	mA
SCL, SDA signal input high level	V_{IHI}	—	3.5	—	5.0	V
SCL, SDA signal input low level	V_{ILO}	—	0	—	0.9	V
Input available maximum frequency	f_{Imax}	—	—	—	100	kbit/s

Note) *1: 00H register: D7 = 0, D6 = 1

• Design reference data

Note) The characteristics listed below are theoretical values based on the IC design and are not guaranteed.

Parameter	Symbol	Conditions	Min	Typ	Max	Unit
Stereo separation (100%)-1	Sep_{100-1}	$f = 300\text{ Hz}$, (L(R)-only) 100%mod	20	35	—	dB
Stereo separation (100%)-2	Sep_{100-2}	$f = 1\text{ kHz}$, (L(R)-only) 100 %mod	17	28	—	dB
Stereo separation (100%)-3	Sep_{100-3}	$f = 3\text{ kHz}$, (L(R)-only) 100%mod	20	35	—	dB
Stereo separation (100%)-4	Sep_{100-4}	$f = 8\text{ kHz}$, (L(R)-only) 100%mod	10	18	—	dB
Stereo separation (30%)-1	Sep_{30-1}	$f = 300\text{ Hz}$, (L(R)-only) 30%mod	22	35	—	dB
Stereo separation (30%)-2	Sep_{30-2}	$f = 1\text{ kHz}$, (L(R)-only) 30%mod	20	35	—	dB
Stereo separation (30%)-3	Sep_{30-3}	$f = 3\text{ kHz}$, (L(R)-only) 30%mod	22	35	—	dB
Stereo separation (30%)-4	Sep_{30-4}	$f = 8\text{ kHz}$, (L(R)-only) 30%mod	14	22	—	dB
Stereo separation (10%)-1	Sep_{10-1}	$f = 300\text{ Hz}$, (L(R)-only) 10%mod	20	35	—	dB
Stereo separation (10%)-2	Sep_{10-2}	$f = 1\text{ kHz}$, (L(R)-only) 10%mod	20	35	—	dB
Stereo separation (10%)-3	Sep_{10-3}	$f = 3\text{ kHz}$, (L(R)-only) 10%mod	20	30	—	dB
Stereo separation (10%)-4	Sep_{10-4}	$f = 8\text{ kHz}$, (L(R)-only) 10%mod	14	22	—	dB

I² C interface

Bus free before start	t_{BUF}	—	4.0	—	—	μs
Start condition set-up time	$t_{SU,STA}$	—	4.0	—	—	μs
Start condition hold time	$t_{HD,STA}$	—	4.0	—	—	μs
Low period SCL, SDA	t_{LO}	—	4.0	—	—	μs
High period SCL	t_{HI}	—	4.0	—	—	μs
Rise time SCL, SDA	t_r	—	—	—	1.0	μs
Fall time SCL, SDA	t_f	—	—	—	0.35	μs
Data set-up time (write)	$t_{SU,DAT}$	—	0.25	—	—	μs
Data hold time (write)	$t_{HD,DAT}$	—	0.3	—	—	μs
Acknowledge set-up time	$t_{SU,ACK}$	—	—	—	3.5	μs
Acknowledge hold time	$t_{HD,ACK}$	—	0	—	—	μs
Stop condition set-up time	$t_{SU,STO}$	—	4.0	—	—	μs

■ Electrical Characteristics at $V_{CC} = 5\text{ V}$, NR: On, $T_a = 25^\circ\text{C}$ (continued)

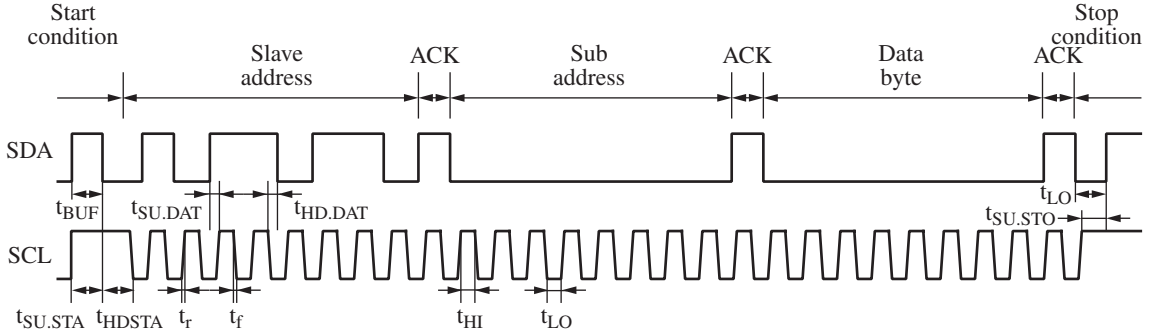

■ Terminal Equivalent Circuits

Pin No.	Equivalent circuit	Description	DC voltage (V)
1		AGC: AGC level sensor pin	0.5 to 2.0
2		AUXIL: External input1 L-ch input pin	2.2
3		AUXIR: External input 1 R-ch input pin	2.2

■ Terminal Equivalent Circuits (continued)

Pin No.	Equivalent circuit	Description	DC voltage (V)
4		<p>OFCAN1: 75 μs filter output Offset cancel pin</p>	2.2
5		<p>OFCAN2: dbx output Offset cancel pin</p>	2.2
6		<p>WBTIME: Wide expander effective value detection recovery time set-up pin</p>	2.2
7	—	V _{CC} : V _{CC} pin	V _{CC}
8		<p>WBDET: RMS detection circuit input pin of wide band expander</p>	2.2

■ Terminal Equivalent Circuits (continued)

Pin No.	Equivalent circuit	Description	DC voltage (V)
9		<p>SPEFIL: Variable de-emphasis level adjusting pin</p>	2.2
10		<p>SPETIME: RMS detection recovery time pin of variable de-emphasis</p>	0.2
11		<p>SPEDET: RMS detection circuit input pin of variable de-emphasis</p>	2.2
12		<p>NOISEDET: Noise detecting pin of SAP malfunction-prevention-circuit(Mute SAP de-modulation at detecting noise.)</p>	$V_{CC} - 2 V_{BE}$

■ Terminal Equivalent Circuits (continued)

Pin No.	Equivalent circuit	Description	DC voltage (V)
13		SAPDET: SAP signal carrier level detection pin	$V_{CC} - 2 V_{BE}$
14		MPXIN: Composite signal input pin	2.2
15		PILOTDET: Stereo pilot signal detection pin	$2.2V_{CC} - 2 V_{BE}$
16		PLL: Stereo PLL low pass filter connection pin	$V_{CC} - 2 V_{BE}$
17	—	GND: GND pin	0

■ Terminal Equivalent Circuits (continued)

Pin No.	Equivalent circuit	Description	DC voltage (V)
18		SCL: I ² C bus clock input pin	—
19		SDA: I ² C bus data input pin	2.2
20		PE: Current application input pin for ZAP at final test	—
21		L-OUT: L-ch. line out output pin	2.2

■ Terminal Equivalent Circuits (continued)

Pin No.	Equivalent circuit	Description	DC voltage (V)
22		<p>R OUT: R-ch. line out output pin</p>	2.2
23		<p>AUX2R: External input 2 L-ch. input pin</p>	2.2
24		<p>AUX2L: External input 2 R-ch. input pin</p>	2.2

■ Usage Notes

1. AGC set-up method

By turning on AGC, the AGC performs 0 dB at a small signal input, Boost at a medium signal and gain reduction at a big signal. It can also control the I/O characteristics of AGC by I²C as shown below:

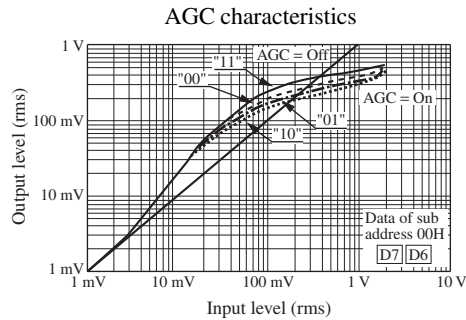

2. Guarantee of I²C operating temperature

I²C bus control operation at an operating ambient temperature is theoretically guaranteed based on IC design by means of the inspection using about 50% faster clock speed at the normal temperature ($T_a = 25^\circ\text{C}$).

Namely it is a theoretical value based on IC design, therefore it is not guaranteed at the shipping inspection because the inspection under a high and low temperature is not conducted.

3. Electrostatic breakdown

Pay attention to the following levels:

Pin 6: 200 pF, 130 V

Pin 10: 200 pF, 150 V

Pin 22: 200 pF, 190 V

■ Technical Information

[1] I²C bus

1. Receiving mode

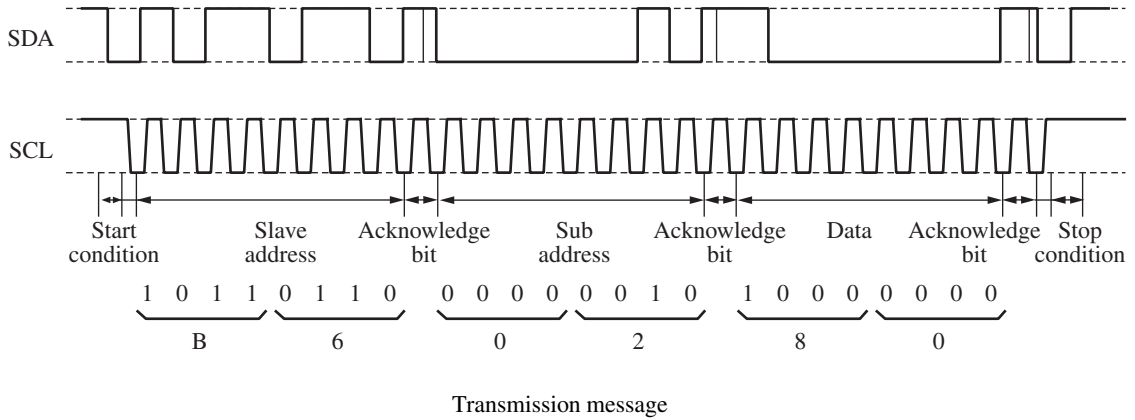

As transfer messages, SCL and SDA are transferred synchronously and serially. SCL is a constant clock frequency and SDA is address data for controlling a receiving side and is sent in parallel by synchronizing with SCL. Data are in principle sent by 8-bit 3-octet (byte) and there exists an acknowledge bit per octet. The frame structure is mentioned below:

- 1) Start condition
When SDA becomes from high to low at SCL = high, the receiver gets ready to receive.
- 2) Stop condition
When SDA becomes from low to high at SCL = high, the receiver stops receiving.
- 3) Slave address
Specified for each device. If any addresses of other devices are sent, receiving will be stopped.
- 4) Sub-address
Specified for each function.
- 5) Data
Data for controlling
- 6) Acknowledge bit
This is the bit that informs the master of data reception every octet. The master sends the high signal and the receiver sends back the low signal as shown with the dotted line in the above figure, thus the master acknowledges reception on the receiver side. If the low signal is not sent back, the reception will be stopped.

Except for the start and stop conditions, SDA does not change at SCL = high.

■ Technical Information

[1] I²C bus (continued)

1. Receiving mode (continued)

<I²C of this IC>

- 1) Enhances adjustment-free mechanism of the TV set thanks to DAC control 3 and 9 switches
- 2) Auto-increment function
 - Sub address 0 *: Auto-increment mode
(Data sequential transfer leads to the sequential change of sub address, so that the data is inputted.)
 - Sub address 8 *: Data renewal mode
(With sequential data transfer, data are inputted in the same sub address.)

3) I²C bus protocol

- Slave address
- Format (normal)

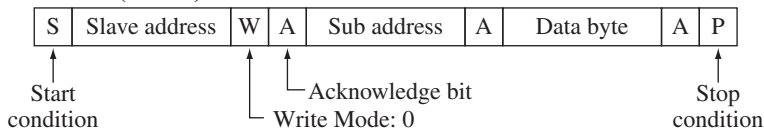

- Auto-increment mode/data renewal mode

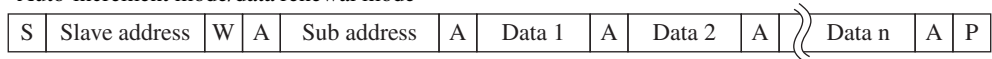

- 4) As the initial state of DAC is not guaranteed, never fail to input the following data in a power on mode.

"06" register: "04"

"00" register: adjustment data

"01" register: adjustment data

"02" register: "00"

"05" register: adjustment data

2. Transmission mode (read mode)

I²C bus protocol

- Slave address: 10110111 (B7H)
- Format

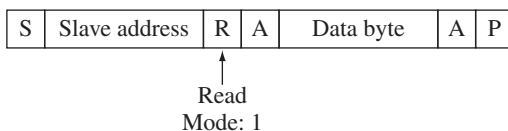

■ Technical Information (continued)

[1] I²C bus (continued)

- Sub address byte and data byte format

Write mode (slave add.: 10110110)

Sub address	Upper MSB		Data byte				Lower LSB	
	D7	D6	D5	D4	D3	D2	D1	D0
"00"	← AGC adj. →		← Input level adjustment →					
"01"	AUXselect 0: AUX1 1: AUX2	AUX SW 0: Off 1: On	← High frequency separation adjustment →					
"02"	Adj.: 1 → On L:VGA out R:VCO f _H	Mute: 1 → On L: Mute R: Mute	AGC 1 → On	0	FMONO: 1 → On L: L+R R: L+R	0	St/SAP 0 → SAP	(L+R)/SAP 0 → SAP
"05"	*	*	*	*	← Low frequency separation adjustment →			
"06"	*	*	*	*	*	*	0	0

* = Don't care

Read mode (slave add.: 10110111)

Upper MSB		Data byte				Lower LSB	
D7	D6	D5	D4	D3	D2	D1	D0
Pilot det. 1 → DET	SAP det. 1 → DET	*	*	*	*	*	*

* = Don't care

■ Technical Information (continued)

[2] Noise detecting operation in SAP receiving mode

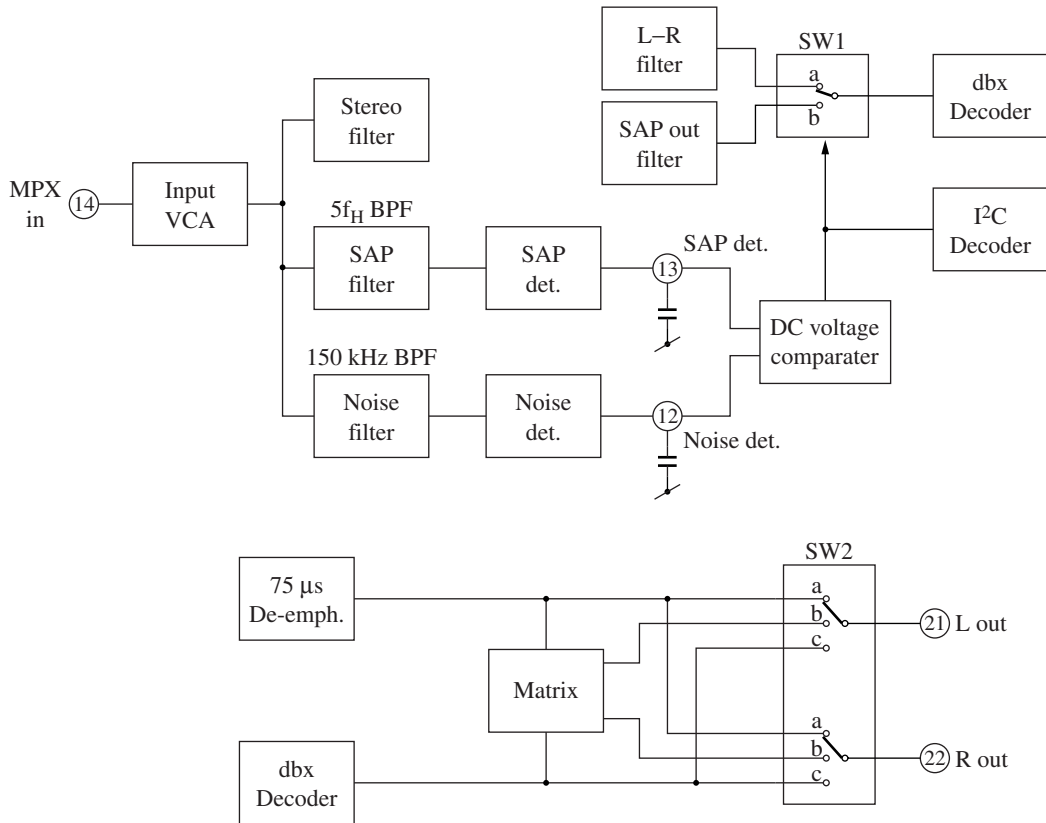

Pin 14 input	"02" register	Pin 12, pin 13 DC voltage	SW1	SW2	I²C SAP det.	Pin 21, pin 22
Noise: Small	"00"	$V_{12} > V_{13}$	b	c	3.5 V to 5 V	SAP
Noise: Large	"00"	$V_{12} < V_{13}$	a	a	0 V to 0.9 V	L+R

■ Application Circuit Example

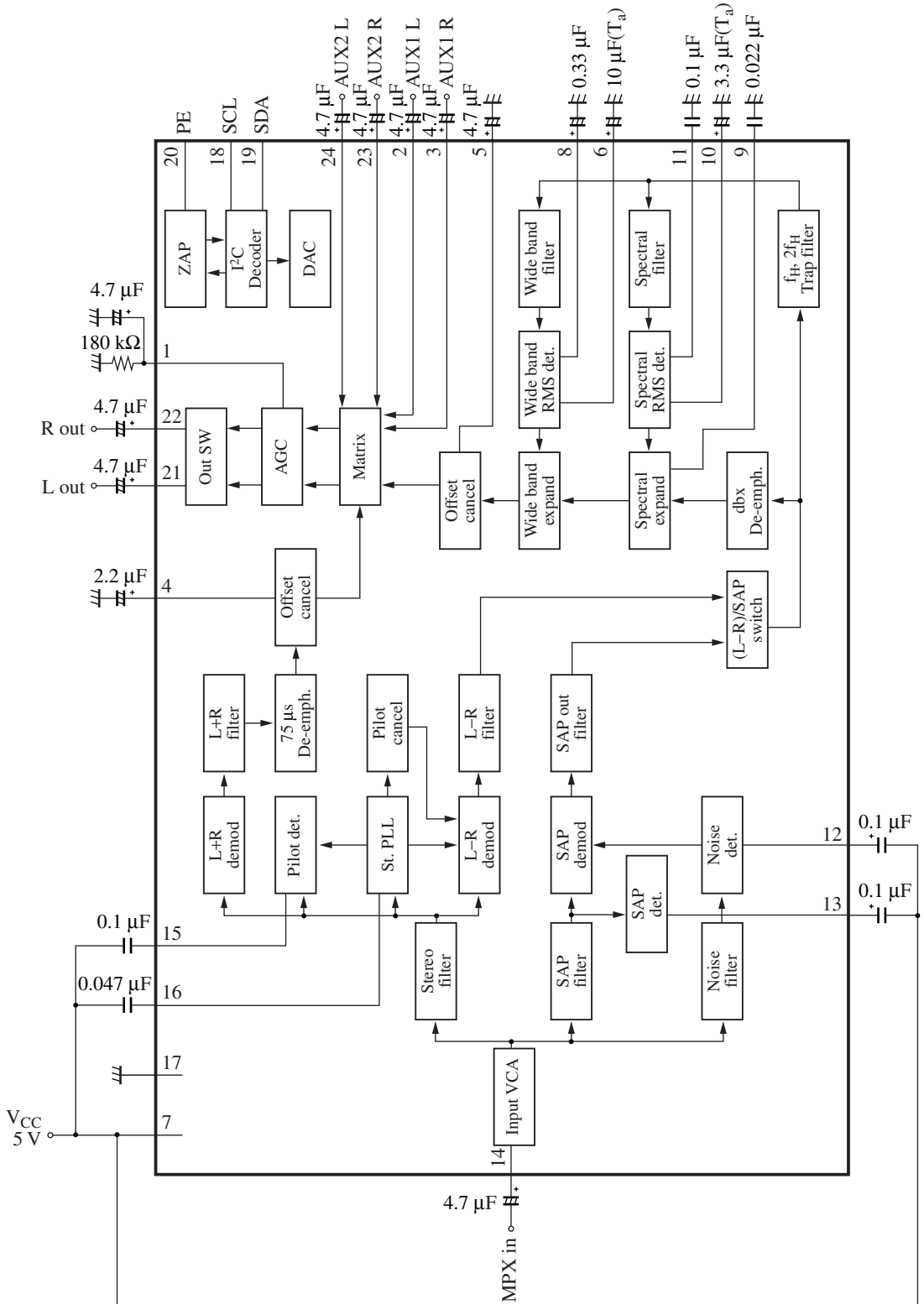

■ New Package Dimensions (Unit: mm)

- SOP024-P-0375C (Lead-free package)

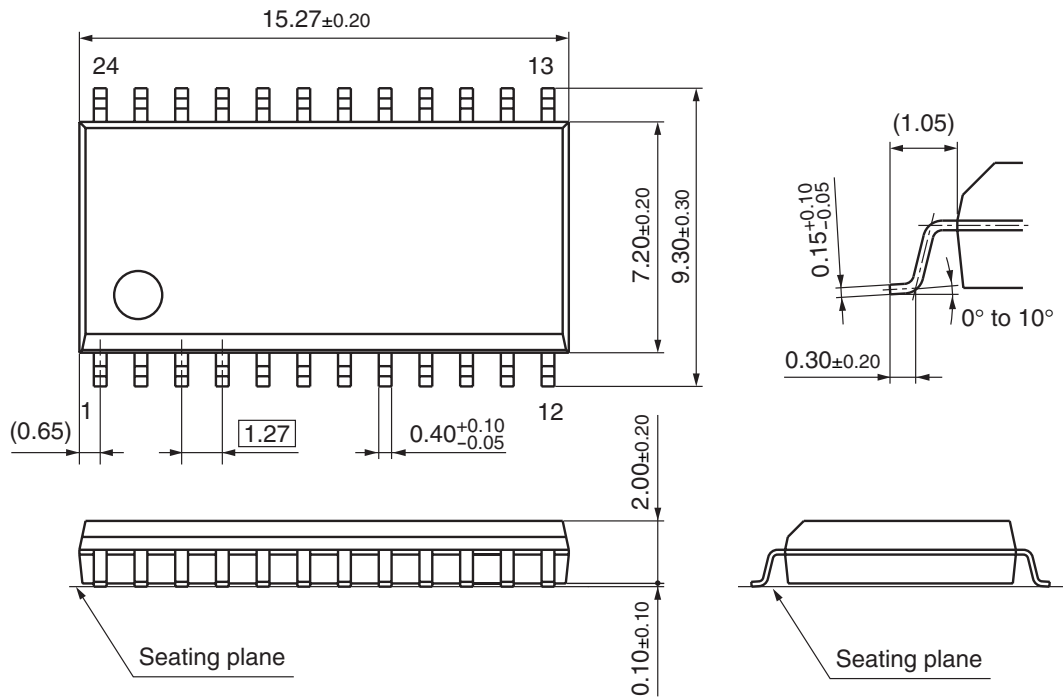

Request for your special attention and precautions in using the technical information and semiconductors described in this material

- (1) An export permit needs to be obtained from the competent authorities of the Japanese Government if any of the products or technologies described in this material and controlled under the "Foreign Exchange and Foreign Trade Law" is to be exported or taken out of Japan.
- (2) The technical information described in this material is limited to showing representative characteristics and applied circuit examples of the products. It does not constitute the warranting of industrial property, the granting of relative rights, or the granting of any license.
- (3) The products described in this material are intended to be used for standard applications or general electronic equipment (such as office equipment, communications equipment, measuring instruments and household appliances).
Consult our sales staff in advance for information on the following applications:
 - Special applications (such as for airplanes, aerospace, automobiles, traffic control equipment, combustion equipment, life support systems and safety devices) in which exceptional quality and reliability are required, or if the failure or malfunction of the products may directly jeopardize life or harm the human body.
 - Any applications other than the standard applications intended.
- (4) The products and product specifications described in this material are subject to change without notice for reasons of modification and/or improvement. At the final stage of your design, purchasing, or use of the products, therefore, ask for the most up-to-date Product Standards in advance to make sure that the latest specifications satisfy your requirements.
- (5) When designing your equipment, comply with the guaranteed values, in particular those of maximum rating, the range of operating power supply voltage and heat radiation characteristics. Otherwise, we will not be liable for any defect which may arise later in your equipment.
Even when the products are used within the guaranteed values, redundant design is recommended, so that such equipment may not violate relevant laws or regulations because of the function of our products.
- (6) When using products for which dry packing is required, observe the conditions (including shelf life and after-unpacking standby time) agreed upon when specification sheets are individually exchanged.
- (7) No part of this material may be reprinted or reproduced by any means without written permission from our company.

Please read the following notes before using the datasheets

- A. These materials are intended as a reference to assist customers with the selection of Panasonic semiconductor products best suited to their applications.
Due to modification or other reasons, any information contained in this material, such as available product types, technical data, and so on, is subject to change without notice.
Customers are advised to contact our semiconductor sales office and obtain the latest information before starting precise technical research and/or purchasing activities.
- B. Panasonic is endeavoring to continually improve the quality and reliability of these materials but there is always the possibility that further rectifications will be required in the future. Therefore, Panasonic will not assume any liability for any damages arising from any errors etc. that may appear in this material.
- C. These materials are solely intended for a customer's individual use.
Therefore, without the prior written approval of Panasonic, any other use such as reproducing, selling, or distributing this material to a third party, via the Internet or in any other way, is prohibited.



LittleDiode supplies new, hard to find or obsolete electronic components and semiconductors all over the world.

With over two million different components listed you are sure to find the part you need.

Feel free to visit us today at our online store:

LittleDiode.com

Looking forward to providing you with the best possible service.